

COOL  
SCHOOL

1998

POW WOW





## *ACKNOWLEDGMENTS*

**Well its finally here, the 1998 Pow-Wow. As you will see within this book much effort was put into it.**

**The 98' Pow-Wow was late in planning due to circumstances beyond our control.**

**As thin as this book is hopefully it will assist you in new and fun ideas.**

**There are many scouters that assisted me in putting all this together, and I say thank you! Please know that I truly appreciate all you did for me, no matter how small a task it was.**

**I would like to give a special thanks to a few people that put alot of extra work in this Pow-Wow. About four years ago, my brother Chuck, sent me about 10 boxes full of Pow-Wow books from National Cap Council and surrounding areas. I knew someday those books would come in handy (told you David). Without the love and support , understanding and long hours I could not have pulled this Pow-Wow together without the help of my family, David, David Jr, Paula, Ken, Krystle and Jamie. (I promise guys no more T.V. dinners for a year ..... and you can now have the computer back. You guys know the true meaning of SCOUT SPIRIT!**

**To the POW-WOW participants it is a sincere hope that you use what you learn here today, and what is in this book, to further scouting in your pack, districts, council and communities.**

**Yours In Scouting**

*Marie Snyder*

**Marie Snyder**

**POW-WOW Chairperson**

## TABLE OF CONTENTS

### NOVEMBER - STOP THE PRESSES

NOV 1	OPENING
NOV 2	ADVANCEMENT CEREMONY
NOV 3	AUDIENCE PARTICIPATION
NOV 4	SONGS

### DECEMBER - LET'S CELEBRATE

DEC 1	OPENING
DEC 2-3	SKITS
DEC 4	SONGS
DEC 5	CLOSING
DEC 6,7,8	CRAFTS

### JANUARY - CUBSTRUCTION

JAN 1	OPENING/CLOSING
JAN 2	ADVANCEMENT CEREMONY
JAN 3	SONGS & GAMES
JAN 4	SKITS

### FEBRUARY - BALOO AND GOLD

FEB 1	OPENING
FEB 2	ADVANCEMENT CEREMONY
FEB 3	CLOSING
FEB 4	ARROW PRESENTATION CEREMONY
FEB 5,6	ARROW OF LIGHT CEREMONY
FEB 7	GRADUATION CEREMONY
FEB 8	GRACES
FEB 9	SKITS
FEB 10	SONGS

### MARCH - GATEWAY TO THE ORIENT

MAR 1	OPENING/CLOSING
MAR 2	GAMES
MAR 3	SONGS
MAR 4	SKITS
MAR 5-8	CRAFTS

### APRIL - POLLUTION SOLUTION

APRIL 1	OPENING/CLOSING
APRIL 2	ADVANCEMENT CEREMONY
APRIL 3	CLOSING AND GAMES
APRIL 4	SONGS
APRIL 5,6	SKITS

## MAY - LEGENDS AND LORE

MAY 1            OPENING/CLOSING  
MAY 2-3        ADVANCEMENT CEREMONY  
MAY 4            SKIT  
MAY 5            SONGS

## JUNE - TRAILS, TRECKS AND TRACKS

JUNE 1          OPENING  
JUNE 2          ADVANCEMENT  
JUNE 3          TIGER GRADUATION CEREMONY  
JUNE 4,5        GRADUATION TO NEXT RANK CEREMONY  
JUNE 6,7        DEN LEADERS RECOGNITION CEREMONY  
JUNE 8          DEN LEADER FAREWELL CEREMONY

## JULY - OUR NATIONAL TREASURES

JULY 1          OPENING/CLOSING  
JULY 2          ADVANCEMENT CEREMONY  
JULY 3          SONGS  
JULY 4          CRAFT  
JULY 5          KNIFE SAFETY

## AUGUST - SPLISH, SPLASH

AUG 1            ADVANCEMENT CEREMONY  
AUG 2,3        SKITS  
AUG 4-6        SONGS  
AUG 7            GAMES  
AUG 8            GAME- CRAFT  
AUG 9            CRAFTS

## SEPTEMBER - HEY, LOOK US OVER

SEPT 1          OPENING  
SEPT 2          ADVANCEMENT  
SEPT 3          CUBMASTER INDUCTION CEREMONY  
SEPT 4          TIGER CUB INDUCTION CEREMONY

## NECKERCHIEF SLIDES

CRAFTS



**NOVEMBER**

**STOP THE PRESSES**

## OPENING CEREMONY

### FOUR FREEDOMS CEREMONY

- PERSONNEL:** Five Cub Scouts, one as Narrator
- EQUIPMENT:** Flag five penlights
- ARRANGEMENT:** Each of four Cub Scouts holds a corner of the United States flag in one hand and a penlight in the other. The flag is tilted so the audience can see it. The Narrator stands behind the flag with a penlight in one hand and his reading material in the other. The Den Chief or another Cub Scouts lights each penlight, then steps back to one side. Lights are turned out.
- NARRATOR:** What you see here represents the past, the present, and the future. the stripes of Old Glory stand for the original thirteen colonies. The stars represent the present states. The Cub Scouts represent the men of tomorrow. The four lights remind us of the great Four Freedoms: **FREEDOM OF SPEECH, FREEDOM OF WORSHIP, FREEDOM FROM WANT, AND FREEDOM FROM FEAR.** Eliminate any one of these freedoms and our world would become darker and colder.  
(PAUSE)  
**FREEDOM OF SPEECH, (one light is turned off)**  
(PAUSE)  
**FREEDOM OF WORSHIP, (another light is turned off)**  
(PAUSE)  
**FREEDOM OF WANT, (another light is turned off)**  
(PAUSE)  
**FREEDOM OF FEAR, (another light is turned off leaving only Narrator's light)**  
(PAUSE)
- NARRATOR:** In this world of potential cold and darkness, of rules by a few, stands the United States of America. Here the Four Freedoms do exist and are an example of light for all. (turn lights back on) Would everyone please stand and join us in God Bless America.

## **ON - THE - AIR ADVANCEMENT CEREMONY**

**Equipment:** Three handheld microphones, real or made of wood; badges and certificates to be award.

**Personnel:** Cubmaster, assistant Cubmaster, Webelos den leader, advancing boys and their parents.

**Cubmaster:** This is Station C - U - B - S, reporting from the pack meeting of Pack .  
Tonight we have selected several of our new listeners for awards. They are to receive their Bobcat badges. Let's welcome them now, (Cubmaster call forward the Bobcat candidates and their parents.)

Boys, please show that you are ready to becomes Bobcats by joining me in the Cub Scout Promise. ( The Cubmaster leads the Promise.) Fine. It's a pleasure to present your Bobcat badges. (The Cubmaster gives the badges to the parents to pin on their sons' shirts.)

**Assistant Cubmaster** (Speaking from the audience) This is the Station C - U - B - S mobile unit out on the Cub Scout trail. We have spotted several Cub Scouts who have reached the Wolf station. I'll send them to your location. (The Wolf candidates and their parents go forward.)

**Cubmaster:** We are very glad that you have completed the 12 achievements to earn your Wolf badges. I know that your parents have helped a lot, so I will give them the honor of pinning on your new badges. (Presents the badges to the parents.)

(Continue in the same fashion for Arrow points and Bear badges. Webelos den leaders use the same method to present activity badges and Webelos badges.)

This is Station C -U -B -S signing off the air but inviting you to stay tuned to the great Cub Scouting in Pack \_\_\_\_\_.

### **CLOSING:**

#### **CUB SCOUT VESPERS**

(Tune: O'tannenbaum)

As the night comes to this land,  
On my Promise I will stand.  
I will help the Pack go,  
As our Pack helps me to grow.

Yes, I will always give goodwill,  
I'll follow my Akela still.  
And before I stop to rest,  
I will do my very best.



## AUDIENCE PARTICIPATION

### COMMUNICATION TROUBLE

Smoke Signals: "Puff-puff, Puff-puff"  
Drums: "Boom, boom, boom, boom,"  
Runner: "Pant, pant, pant, pant,"  
Telegraph: "Dash-dot-dot, Dash-dot-dot"  
Telephone: "Ding-a-ling, Ding-a-ling"  
Telestar: "Beep-beep-, Beep-beep"  
Woman: All Sounds Together

One night as C.M. (civic minded) Citizen finished dinner, he realized that as usual, he and his wife were alone at the table. Daughter had to be excused for an important TELEPHONE \_\_ call. Older son wanted to get to work on the TELEGRAPH \_\_ set he was building and Young Son had dashed off to the basement where he was busily practicing on his bongo DRUMS \_\_.

"Well", said Mr. Citizen to his wife, "I've finally decided that I simply can't take the chairmanship of the Building Committee. I'm going to TELEPHONE the Mayor right away to let him know. Mrs. Citizen murmured that it was a wise decision, and than began clearing the table.

Mr. Citizen found his Daughter still talking on the TELEPHONE \_\_, so he picked up the newspaper and tried to concentrate even though the beat of the DRUM \_\_ in the basement made It difficult. After a few minutes, he finally managed to get the TELEPHONE \_\_, all he got after dialing was a busy signal. "Oh, no" he said. "One of the Mayor's kids is probably having a long-winded conversation."

Mr. Citizen stomped back into the living room to wait some more. He turned on the TV set in time to hear the announcer say the program was coming from Europe via TELESTAR \_\_. Mr. Citizen thought, "here we live in an advance age of communications with programs coming from thousands of miles away, and I can't even get a TELEPHONE \_\_ call through.

When Mr. Citizen tried to TELEPHONE \_\_ again, he found his Older Son already talking to one of his buddies about his TELEGRAPH set. Just then, Young son appeared in the living room with his DRUMS \_\_. "No more of that tonight", said Mr. Citizen, "Although I may resort to sending a message by DRUMS \_\_ before I'm through". "I'm learning to send SMOKE SIGNALS \_\_ in Cub Scouts" said Young Son. "I can teach you how."

Mr. Citizen dialed again and found a busy signal. "Maybe I should hire a RUNNER \_\_", said he. "Too bad my terrific TELEGRAPH \_\_ set isn't working Dad. You could have sent your message by Morse Code."

Finally Mr. Citizen was able to get the mayor. He said, Mr. Mayor, I called to tell you that I can't serve on the Building Committee". The Mayor said "Yes, I know . My wife just got back from a bridge party and it seems your wife told her you had decided not to take the job", "Well", said Mr. Citizen. "I'm a little surprised, but I really shouldn't be. I've always heard that the best way to broadcast news is to TELEPHONE \_\_, TELEGRAPH \_\_, or TELL A WOMAN \_\_!"

## SONGS

### COMMERCIAL MIX-UP

(Tune: "Farmer in the Dell")

Last night I watched TV,  
I saw my favorite show,  
I heard this strange commercial,  
I can't believe it's so.

Feed your dog Chiffon,  
Comet cures a cold,  
Use S.O.S. pads on your face  
To keep from looking old.

Mop your floor with Crest,  
Use Crisco on your tile,  
Clean your teeth with Borateem,  
It leaves a shining smile.

For headaches take some Certs,  
Use Tide to clean your face,  
and do shampoo with Elmer's glue,  
It holds your hair in place.

Perhaps I am confused,  
I might not have it right.  
To make sure that I understand,  
I'll watch TV tonight.

## GAME

### CALENDAR PITCH GAME

Glue a large calendar page on cardboard or wood. Standing about five feet away, players (one at a time) toss three checkers each toward the target. The score is the total of the numbers on which the checkers land. No score is given for checkers that land on the lines. For added excitement, double the score for holidays.

### A THANKSGIVING SONG

(Tune: "Polly-Wally Doodle")

Oh, a turkey tom and a turkey mom,  
Go gobble, gobble, Gobble all day,  
Oh, they love to be with their family,  
And gobble, gobble, gobble, all day.

Arm in arm, on the farm  
As they strut their merry way,  
Oh, a turkey tom and a turkey mom,  
Go Gobble, bobble, gobble all day.

When the moon goes down,  
And the sun comes up,  
They gobble, gobble, gobble all day  
Oh, a turkey tom and turkey mom,  
Go gobble, bobble, gobble, all day.

### TOMMY, THE TALL-TAILED TURKEY

Tune: "Rudolph, the red nosed reindeer"

Tommy, the tall-tailed turkey,  
Had a big enormous tail,  
And when he starts in running,  
It will make a windy gale.

All of the other turkeys,  
Teased poor Tommy every day,  
'Cause when he spreads his feathers,  
With them he could not play.

On Thanksgiving morn one year,  
When fire burned the barn,  
Tommy waved his tail so hard,  
And stopped it without harm.

Now all the other turkeys,  
End up on a great big dish,  
But on Thanksgiving morning,  
Tommy and his tail still swish.

**DECEMBER**

**LET'S CELEBRATE**



## STANDARD FLAG CEREMONY

**Personnel:** Flag bearers and color guards for American flag and Pack flag. (If there is uneven number of color guards, the American flag has precedence and should have the most guards.)

**Equipment:** American flag, Pack flag, flag stands, recorded music if desired.

**Setting:** Flag stands are in place at front of room or on stage. Flag bearers and color guards are in position in rear of room. Speaker may be in rear of room or in any convenient place nearby. Cubmaster usually calls the meeting to order and introduces the den who will perform the ceremony. At this time, the speaker advances to the front of the room. (Make certain he can be heard by everyone)

**Speaker:** ATTENTION! WILL THE AUDIENCE PLEASE RISE. COLOR GUARD, PRESENT THE COLORS! (or "Color guard, advance")  
Speaker's commands should be given loud and clear.

Color guard advances from rear of room with flag bearers in front, followed by guards. The American flag should always be on the marching right in the procession. As procession begins, speaker gives his next command.

**Speaker:** HAND SALUTE! (He salutes and audience does likewise) Speaker's eyes should follow the American flag until it is in position in front of the room.

Flag bearers and color guards take position in front of room, near flag stands. They stand at attention, facing the audience. The flags are held vertically.

**Speaker:** PLEASE REPEAT THE PLEDGE OF ALLEGIANCE WITH ME. (He begins Pledge with Audience joining in)

At this point, the Pack flag is lowered slightly and full attention is given to the American flag. Take care neither touches the floor. Flag bearers and color guards do not salute or repeat pledge.

When Pledge is finished, the speaker gives the next command which is the signal for all salutes to be dropped. The pack flag is then raised again to a vertical position.

**Speaker:** TWO! COLOR GUARD, POST THE COLORS!

The American flag is placed in its stand; then flag bearer and color guard salute it and step back into place. The Pack flag is then posted; its bearer and guard salute it and step back into place. (The American flag is always posted or raised first, and removed or lowered last.)

**Speaker:** COLOR GUARD, DISMISSED! Flag bearers lead procession to back of room, with speaker following last.

For advancement ceremony use Program Helps page 6 DEC, Lighting The Tree Advancement Ceremony.

## **TWELVE PHASES OF SCOUTING**

**STAGING:** (twelve days of Christmas) This is a skit for Leaders an/or Parents to put on for the boys. For each phase that person dresses the part.

1st. - continued computer paper, 2nd - person with rope tied all around them, one big mess, 3rd - all kinds of craft material stuck to them, 4th - inter tubes painted yellow and red, person in side of them, 5th - 5 boys all trying to get their attention, 6th - the bigger the spiders the better, 7th - skill awards on cardboard, 8th big merit badges, 9th wash basket over flowing with clothes, 10th - come in looking like you hiked 10 miles, 11th - small piece of canvas over head, you are all wet, 12th come in looking real serious. This works best if boys can not see you until its your turn and each person sings their phase.

In the 1st phase of Scouting, my son brought home to me an application for den three.

In the 2nd phase of Scouting, my son brought home to me two knots to tie and an application for den 3.

In the 3rd phase of Scouting, my son brought home to me three arts and crafts, two knots to tie, and an application for den 3.

In the 4th phase of Scouting my son Brought home to me four colored beads, 3 arts and crafts, 2 knots to tie, and an application for den 3.

In the 5th phase of Scouting my son brought home to me 5 Cub Scouts, 4 colored beads, 3 arts and crafts, 2 knots to tie and an application for den 3.

In the 6th phase of Scouting my son brought home to me 6 silly spiders, 5 Cub Scouts, 4 colored beads 3 arts and crafts, 2 knots to tie, and an application for den 3.

In the 7th phase of Scouting my son brought home to me 7 Skill Awards, 6 silly spiders, 5 Cub Scouts, 4 colored beads, 3 arts and crafts, 2 knots to tie, and an application for den 3.

In the 8th phase of Scouting my son brought home to me 8 merit badges, 7 skill awards, 6 silly spiders, 5 Cub Scouts, 4 colored beads, 3 arts and crafts, 2 knots to tie, and an application for den 3.

## TWELVE PHASES OF SCOUTING CON'T

In the 9th phase of Scouting my son brought home to me 9 nights of camping, 8 merit badges, 7 skill awards, 6 silly spiders, 5 Cub Scout, 4 colored beads, 3 arts and crafts, 2 knots to tie, and an application for den 3.

In the 10th phase of Scouting my son brought home to me 10 miles of hiking, 9 nights of camping, 8 merit badges, 7 skill awards, 6 silly spiders, 5 Cub Scouts, 4 colored beads, 3 arts and crafts, 2 knots to tie, and an application for den 3.

In the 11th phase of Scouting my son brought home to me 11 leaky tents, 10 miles of hiking, 9 nights of camping, 8 merit badges, 7 skill awards, 6 silly spiders, 5 Cub Scouts, 4 colored beads, 3 arts and craft, 2 knots to tie and an application for den 3.

In the 12th phase of Scouting my son brought home to me 12 points of ponder, 11 leaky tents, 10 miles of hiking, 9 nights of camping, 8 merit badges, 7 skill awards, 6 sill spiders, 5 Cub Scouts, 4 colored beads, 3 arts and crafts 2 knots to tie and an application for den 3.

### CHEERS

RUDOLPH APPLAUSE: Put thumbs to head with fingers up, forming antlers. Wrinkle nose while saying "BLINK, BLINK, BLINK, BLINK"

SLEIGH: Bob up and down on chair like riding in a sleigh and say "TING - A - LING" (3 times)

GOOD-BYE SANTA: Pretend to throw a pack onto your back and say, "Merry Christmas to all, and to all a good night."

### CLOSING THOUGHT

A hundred years from now it will not matter what my bank account was, the sort of house I lived in, or the kind of car I drove but the world may be a different because I was an important part in the life of a boy.



## SONGS

### TOMMY THE CUB SCOUT

Tune: Frosty the Snowman

Tommy the Cub Scout  
Was a very happy boy;  
with a uniform of blue and gold  
And a den that gave him joy.  
Tommy the Cub Scout  
Earned his badges one by one  
He did his best and he met the test;  
A good citizen he's become.

He helps out other people  
when he sees they need a lot,  
He does his chores around the house  
and feeds his dog named spot.  
Tommy the Cub Scout  
Does his duty willingly  
Someday he'll join a Boy Scout troop,  
And a Fine man he will be.

### CLOSING FAMILY VESPERS

(Tune: "Oh, Christmas Tree")

Quietly we join as one,  
Thanking God for family Fun.  
May we now go on our way,  
Thankful for another day.  
May we always love and share,  
Living in peace beyond compare  
As a family may we find  
Friendships true with all mankind.

### CHOCOLATE COOKIE

Chocolate cookie,  
Chocolate cookie,  
Chocolate cookie,  
Yum, Yum, Yum,

Chocolate cookie  
Chocolate cookie  
Chocolate cookie  
Yum, Yum, Yum,

An Oreo, A chocolate Oreo,  
I love the creamy middle of,  
A chocolate Oreo.

Cookie, cookie, cookie,  
Cookie, Yum!

### DEN YELLS

Show us some action!  
Show us some spark!  
All for Den #'s  
Stand up and bark!

Clap you hands,  
Slap your thighs!  
Den #'s  
Flyin high!

## **CLOSING CEREMONY WHO ELSE?**

Have all the cub Scouts and Webelos line up at the front of the room with a spotlight and the adults reading the following parts from the back of the room.

**Asst. Cubmaster:** Boys, are the nicest things that ever happened to me... those arrogant, self-assured, cocky little men-children who assume that all the great big world revolves around them.

**Den Leader:** Who else can carry half a worm, one crushed daisy, a piece of scrapmetal, a three - day - old apple core, and two cents all in one pocket?

**Den Leader:** Who else can take a bath without getting their shoulders wet, and wash for dinner without turning on the faucet?

**Den Leader:** Who else can believe that right is right and wrong is wrong, and the good guy always wins in the end?

**Den Leader:** Who else can be a fireman, sword fighter, cowboy, deep-sea-diver, all in the space of an hour . . . and then solemnly hold a funeral, complete with cross and box, for a shell off a turtle lost a month ago?

**Webelos Leader:** Who else can be a cutter without teeth, meaner with-out malice, kinder without embarrassment, sillier without foolishness, and clean without neatness?

**Committee Chr.:** The world gains much in leaders and man power when boys grow up ... but it loses something too... that magic feeling that comes with being nine! The feel of dust between bare toes and the ability to lie quietly while time stands still, to watch a minnow in a brook.

**Cubmaster:** Me...I like Cub Scouts... the boys! They smile when I need a smile; they tease when I'm somber; they keep me from taking myself too seriously. No, I don't wish that I were nine again. I just hope that somehow God will see to it that I always have someone nine years old in or near my house and heart.

**ALL:** Cub Scouts are the nicest thing that ever happened to me!!!

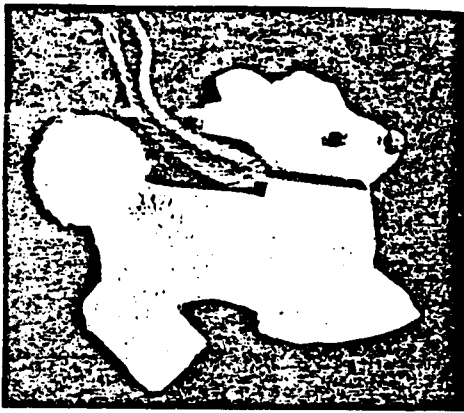

## SANDPAPER MAN AND REINDEER

Coarse sandpaper  
Pencil  
Strong scissors  
White glue  
Felt scraps—red, green, blue, white,  
and black

Scraps of green medium size  
rick-rack  
Yarn  
Cotton

Trace the outlines of the gingerbread man and reindeer on the smooth sides of 2 pieces of sandpaper. Cut out both shapes and glue the smooth sides together. Let dry.

Decorate as follows: Use felt for eyes, mouth, hat, trousers, and belt, rick-rack for suspenders, yarn in strips for bangs under the hat, and cotton for a beard. Decorate both sides. Make a yarn loop at the top of the hat for a hanger.

Give the reindeer a cotton tail, a harness made out of rick-rack or yarn, an eye of black felt, and a red felt nose.

These cutouts can be dressed as elaborately as your imagination suggests.

Contributed by Mrs. Charles E. Thwaite III  
Atlanta, Georgia

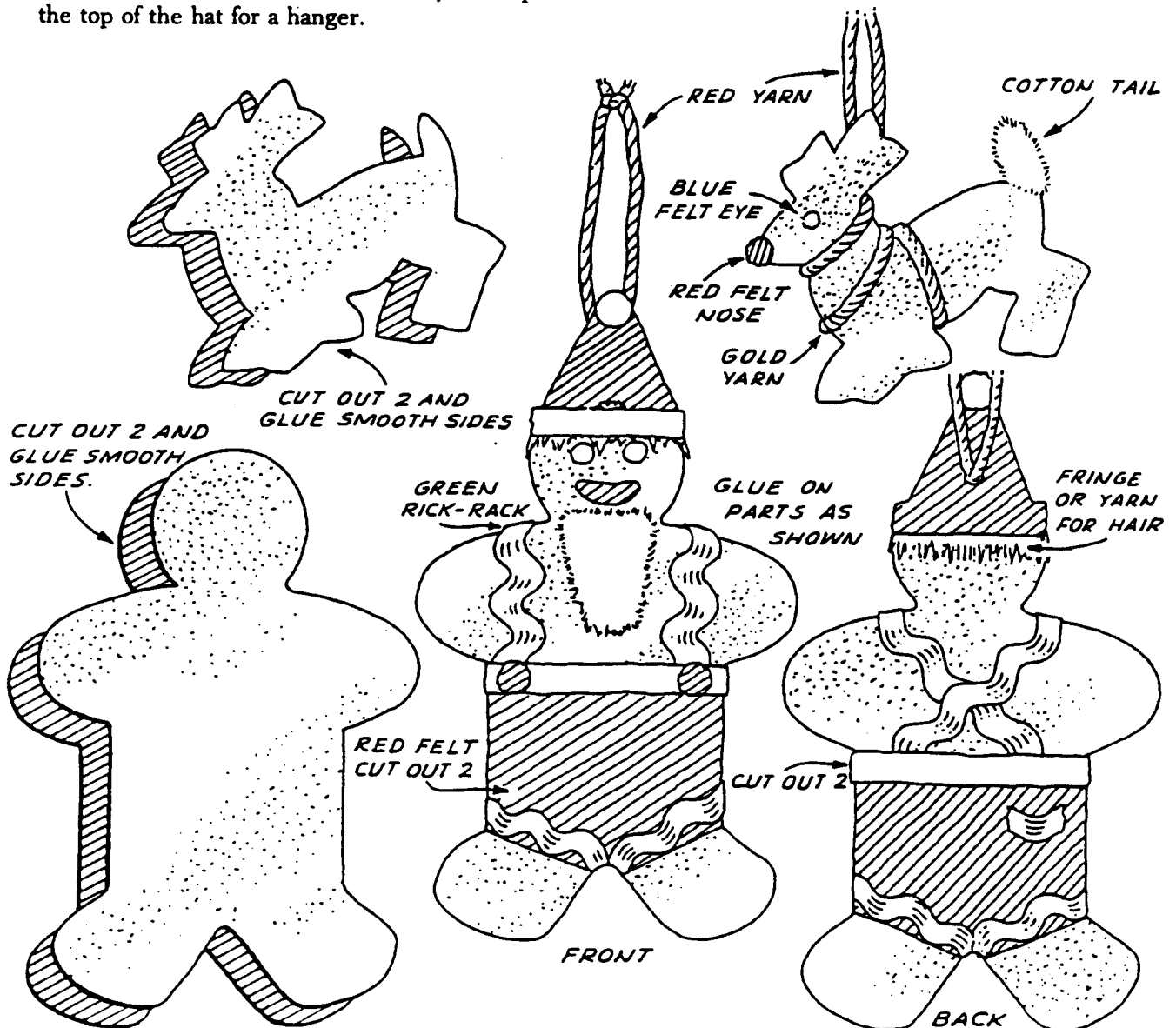

ALL PATTERNS  
ACTUAL SIZE

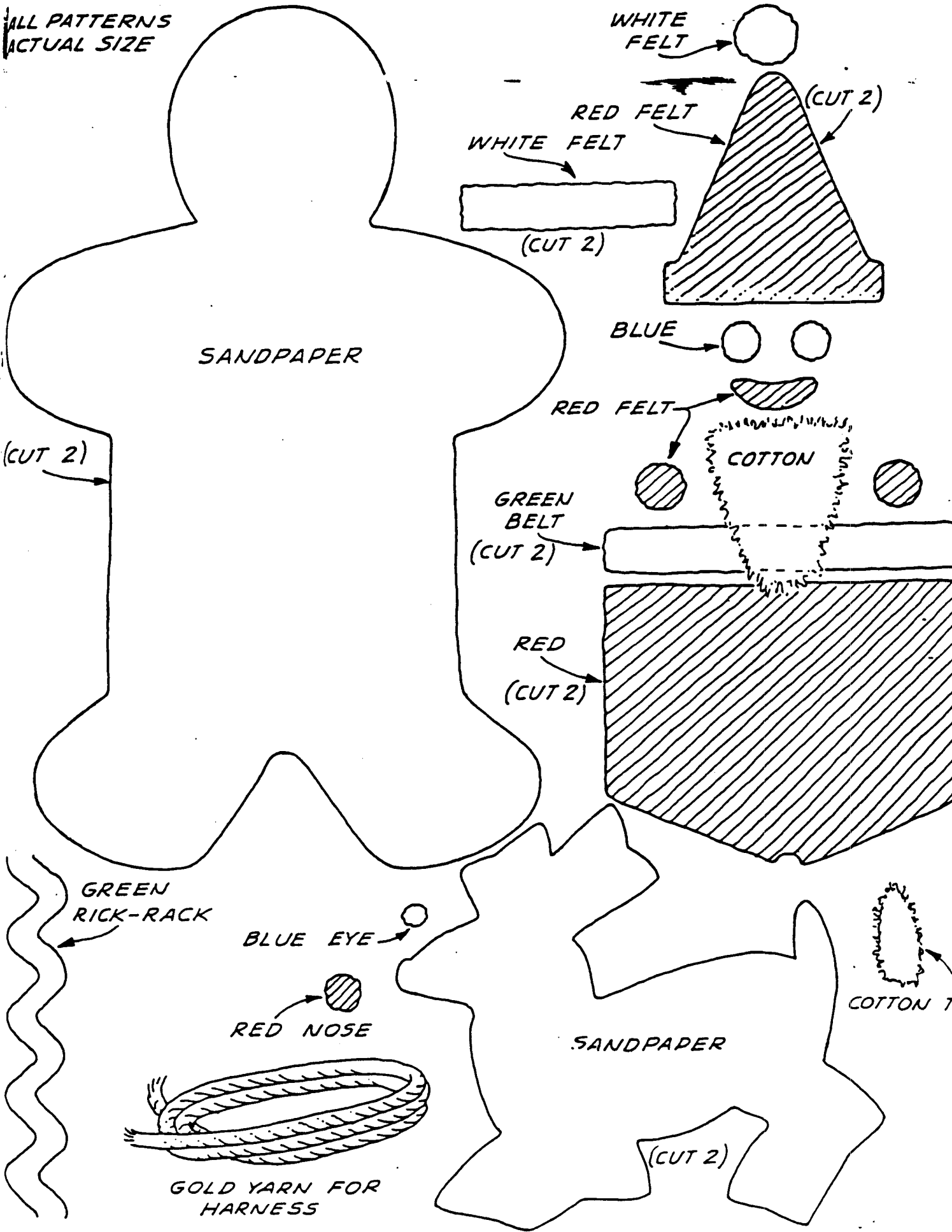

## REINDEER NOTE HOLDER

Materials: Clip clothespin  
5" of  $\frac{1}{4}$ " dowel  
2"x2"x $\frac{1}{2}$ " block of wood  
red, brown felt  
orange, red, green chenille sticks  
bell

Drill hole to fit dowel in center of the block.  
Take clothespin apart and drill the same size hole at an angle in one flat side.  
Drill two small holes (to fit chenille stick) in the other flat side of the clothespin.

Put clothespin back together.

Stain the clothespin, the block and the dowel.

Glue the dowel into the block and the clothespin.

Cut brown felt ears and glue in place.

Cut small red felt dot and glue on nose.

Cut orange chenille stick in half and bend each half into antler shape. Glue one into each small hole.

Cut 4" pieces of red and green chenille stick. Center bell on one of the pieces, then twist the red and green together candy cane fashion.

Wrap this around the neck and twist together in back.

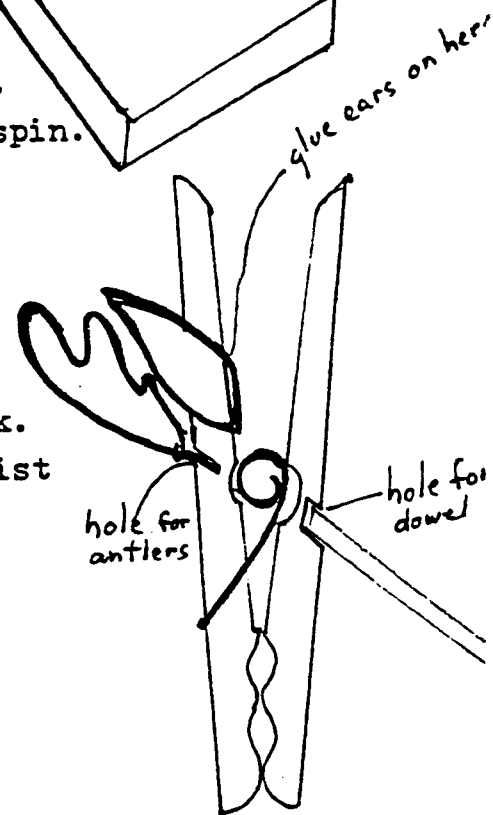
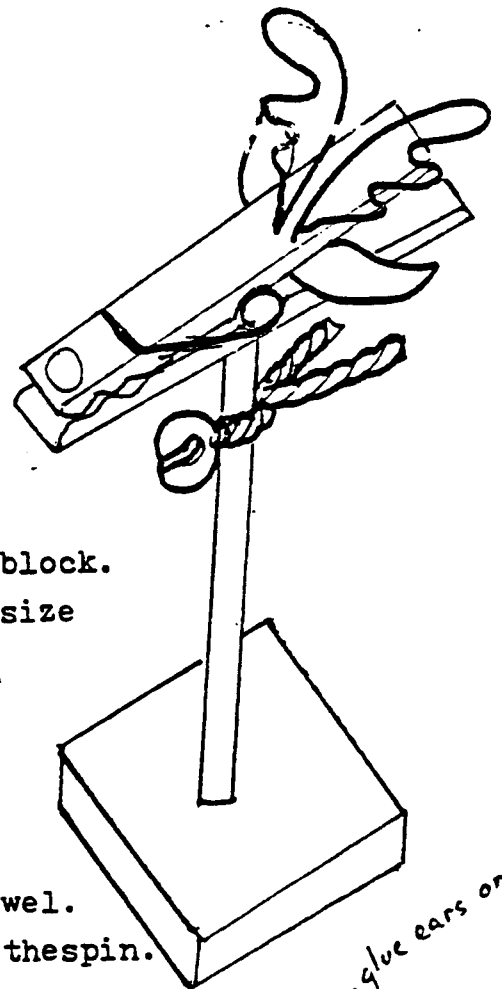

**JANUARY**

**CUBSTRUCTION**

## OPENING OR CLOSING CEREMONY

### CARS, CARS, CARS

Narrator reads the lines below while 6 Cub Scouts, one by one, come on stage, carrying cardboard models of the cars they represent ..... or large posters showing pictures of the cars.

**NARRATOR:** The favorite transportation in America, we feel, is Henry Ford's invention, the automobile. We all have our favorites, that you will know as we show you our cars, now on with the show.

**TOYOTA:** I'm a Toyota, oh so small, wind me up and I can crawl, Drive me out to the end of town. Then pick me up turn me around.

**CADILLAC:** I'm a shiny Cadillac, driving to the store and back, I can purr so quietly, you can sleep while riding in me.

**B.M.W:** I'm a little BMW bug, so lovable, just give me a hug. drive me up the hill so slow, then down the other side we'll go

**DODGE:** I'm a Dodge with lots of class, built for many a lad and lass, I can go most any place, and I hold my own in any race.

**OLDSMOBILE:** The merry Oldsmobile I'm called, with all the latest. I'm installed; shiny things are here and there, so you can drive me anywhere.

**CHEVROLET:** I'm a Chevy, plain and neat, I have a very comfy seat, I'll perform for all who ask, doing every little task.

# RACE TRACK ADVANCEMENT CEREMONY

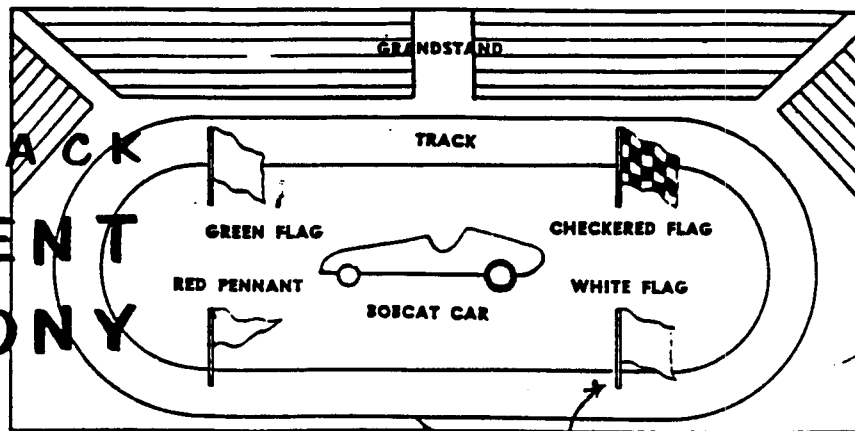

This advancement ceremony will tie in with the pinewood derby. The advancement trail is pictured as a race in which all participate.

MADE OF CARD-  
BOARD OR PLYWOOD

FLAGS AND  
CAR ARE  
CUTOUTS.

## RACE TRACK

### ADVANCEMENT CEREMONY

Personnel: Cubmaster; den chief

Equipment: Racetrack board with cutouts of racing car, red trophy pennant, and green, white, and checkered flags; cellophane to color flags; flashlight for Cubmaster or the other narrator; badges pinned on small cutouts (racing car for Bobcats, appropriate flags for Wolf, Webelos, and Arrow of Light, and red trophy pennant for Bear).

Setting: Room is darkened. Den chief stands with flashlight behind cutouts. At the appropriate time, he illuminates cutout. Cubmaster or other narrator, using flashlight, reads script.

Cubmaster: In an auto race, drivers must advance in position. Tonight we have a special way to honor our racing drivers who have advanced in their Cub Scout rank.

#### Bobcat

Cubmaster: The first step in any race is to establish a qualifying time. Tonight we have some new bobcats who have qualified as drivers on our Cub Scout advancement track (den chief holds flashlight behind racing car

cutout. Cubmaster continues with a regular bobcat induction ceremony.)

#### Wolf

Cubmaster: The green flag symbolizes those drivers who have qualified for a wolf position on our advancement track. Will the following Cub Scouts come forward to receive their Wolf badges (or arrow points) and green flags. (Den chief illuminates green flag cutout with flashlight. Cubmaster reads names of Cub Scouts.)

Because your parents were cheering for you and helping you, we would like them to come forward and present the badge to you.

#### Bear

Cubmaster: The trophy pennant indicates that a driver is more experienced and skillful in handling his car and is moving up among the track leaders. Will the following Cub Scout please come forward to receive their Bear Badges (or arrow points) and red trophy pennants. (Den chief illuminates red trophy pennant. Cubmaster reads names of boys.)

Just as pit mechanics help drivers to refuel and change parts, so your parents have helped you. Will the parents come forward to share in your honor. (parents present badges.)



## Webelos

Cubmaster: The white flag tells us that the driver has but one lap to go to reach the checkered flag - Webelos rank. He has learned to manage the turns, jams, and upsets.

Will the following please come forward to receive their Webelos badge (activities pins) and white flags which show that they are on the last lap of the advancement track. (den chief illuminates white flag. Cubmaster reads names.)

Many a driver wins because of the support given by his pit crew. Your parents helped you achieve your new rank. I know they will be proud to come forward now and share in this honor by presenting these badges to you (parents present badges.)

## Arrow of Light

Cubmaster: The checkered flag announces the end of the race. It shows that the driver has reached the goal and has won the right to go on to bigger tracks - the Indianapolis 500 - which is Boy Scouting. Will the following boys come forward for our highest track award the Arrow of Light and their checkered flags (den chief holds flashlight behind checkered flag. Cubmaster reads names.)

Boys, your parents have helped you to be square and game, and since they traveled this track to Arrow of Light with you, we would like them to come forward now and present the Arrow of Light to you (parents present badges.)

## PINEWOOD DERBY SONG

(Tune: Camptown Races)

Cub Scouts all join in the song,  
Doo-dah, doo-dah!  
Pine car track is mighty long,  
Oh, doo-dah day!

Chorus:

Going to run so fast,  
Going to get ahead.  
Bet my money on a blue pine car,  
Somebody bet on the red.

Red cars, blue cars, green and gray,  
Doo-dah, doo-dah  
Running on the track today,  
Oh, doo-dah day!

Chorus

They're the pride of all the lads,  
Doo-dah, doo-dah!  
Built by Cub Scouts, moms, and dads,  
Oh, doo-dah day!

Chorus

## GAME AUTO RACE

Arrange Cub Scouts in a circle, with the den chief in the center. He gives each player the name of an automobile, being sure to use the same name more than once so that several players have the same car. To start play, the den chief then calls out the name of an auto. The first player with that car name to touch him and return to his place wins the race. The game continues as the den chief calls out another auto.

## THE BUS TRIP

**SCENE:** Players sit on chairs arranged as bus seats. One Cub is the driver who sits in front and turns an imaginary steering wheel.

1. The driver announces that they are about to take a sightseeing trip. The players ad lib eager remarks, such as sounds like fun, etc.
2. The trip starts. The players peer out of the imaginary windows and remark, one at a time, about the interesting scenery.
3. The driver calls, "Hang on, we're going up a steep hill." The players lean back. When the driver announces that they are going downhill, the players lean forward.
4. The driver says that they are passing the Grand Canyon of Arizona, then a few seconds later that they are now crossing the Hudson River into New York. Someone says: "I don't even remember crossing the Mississippi." The driver boasts, "Fast trip!"
5. The passengers grow quiet, and finally drop their heads in sleep. As the driver calls, "Lunch time", they jerk upright and scramble off the bus.
6. After eating a few moments, the driver suggests that they look around. As they do so, someone calls out, "look .... an African lion! But how could we be in Africa?" The driver looks at an imaginary map, shrugs and remarks: "wrong road."
7. As they resume trip, driver calls "Hang on! Bumpy road ahead." The passengers bounce up and down.
8. Driver announces they are passing through the desert. Players wipe brows and loosen collars. When driver announces they are in mountains, passengers huddle and button up collars.
9. Driver calls: "Home again." Everyone gets off bus - walk to wings, looking around, in surprise. Someone says: "Is our home in China?"

### CHEERS

**JET PLANE** Swish your hands across in front of you like a jet and clap your hands twice, real fast.

**LOCOMOTIVE:** Begin by slapping your left arm slowly with your right hand. gradually increase speed, working down over the left palm, peering into distance. Imitate train whistle - "WHOO - WHOO".

**FEBRUARY**

**BALOO AND GOLD**

## **SPIRIT OF LORD BADEN-POWELL**

The Narrator. the "Spirit of Lord Baden-Powell" is a Den Leader in full uniform, wearing a campaign hat. They read the entire script from a lectern.

**NARRATOR:** I represent the spirit of Lord Baden-Powell, the founder of Boy Scouting. I am also the spirit of Scouting past and present. Here is our future, Cub Scouts of America.

(First Cub Scout enters carrying toy church or Bible.)

**NARRATOR:** we take turns praying in our dens. I like to wear my uniform to church on Scout Sunday. Nearly half of all Cub Scout Packs in America are sponsored by churches.

(Second Cub Scout approaches in complete Cub Scout uniform .)

**NARRATOR:** The two colors of the Cub Scout uniform have a meaning. Blue stands for truth and loyalty; gold for good cheer and happiness.

(Third Cub Scout enters carrying Wolf Cub Scout book and Kipling's "The Jungle Book".)

**NARRATOR:** Early Cub Scout Ceremonies were base on Kipling's Jungle tales. When Cub Scouting was organized in America in 1929, Indian themes were used.

(Fourth Cub Scout enters with a craft project of wood.)

**NARRATOR:** Cubbing means fun. We have lots of fun. But we like making things, real boy projects, things we can play with or that follow our theme.

(Fifth Cub Scout carries in nature collection)

**NARRATOR:** I like to go on hikes and collect things for my nature collection or the den museum.

(Sixth Cub Scout enters with a "bubby" burner.)

**NARRATOR:** I like to go on picnics. We Cubs sure do like to eat. This is the cook stove I made.

(Seventh Cub Scout, the smallest boy, enters with American flag.)

**NARRATOR:** I am proud to be an American so I can salute our flag. I also like to see our Pack flag because then I know I am part of 88 years of Scouting. I belong. Yes, I represent the past and present years of Scouting. I belong. Yes, I represent the past and the present. These boys, Cub Scouts now, are the men of tomorrow. They will be preservers of American heritage. Please stand and join us in singing "God Bless America".

## **AKELA'S LIFE STORY** (advancement ceremony)

**Equipment:** Ceremony board or log with three small candles and one large candle; tom-tom; artificial council fire.

**Setting:** Tom-tom beats. Akela enters and walks behind the fire. Akela gives the Cub Scout sign and tom-tom beating stops.

**Narrator:** Akela was the big Chief of the Webelos tribe; tall, stalwart, straight as an arrow, swift as an antelope, brave as a lion - he was fierce to an enemy but kind to a brother. Many trophies in his teepee.

His father was the son of the great yellow sun in the sky. He was called the "Arrow of Light". His mother, from whom he learned those wondrous things that mothers know, was called "Kind Eyes".

His father helped him make a little bow and arrow and once, when an enemy would have tomahawked his mother, he, Akela, from his papoose basket shot the pursuing enemy in the eye, and his mother escaped. A little later, he began to understand the signs and calls of the Webelos tribe. Then he was taken on little trips into the forest among the great trees and streams. Here, from the wolf, he learned the language of the ground; the tracks and ways to food.

(At this point, Akela lights the large candle representing the "Spirit of Akela" and using that, lights the small wolf candle.)

**Akela:** With this candle, representing the "Spirit of Akela", we light the trail of the Wolf. From the signs along the Wolf trail, I see that the following braves are ready for advancement in the "Wolf Clan" of Akela's tribe. (Akela calls names of boys receiving /wolf badge and arrow points. They came forward and stand before council fire. Akela Presents their awards).

**Narrator:** Then from the big, kindly bears, he learned the secret names of the trees, the call of birds - the language of the air.

**Akela:** (Lighting Bear candle) With the "Spirit of Akela" we light the bear trail. From the signs along the Bear Trail. I see that the following braves are ready for advancement in the "Bear Clan" of the Akela's tribe. (He calls forward boys who are receiving Bear badges and arrow points).

**Narrator:** But before he could become a scouting "brave" on his on his own, he had to prove himself by trying out new skills, performing certain tasks and passing tests of accomplishment.

**AKELA'S LIFE STORY**  
(advancement ceremony con't)

Akela: (Lighting Webelos candle) With the "Spirit of Akela" we light the trail of the Webelos. From the signs along the Webelos trail, I see that the following braves have shown their skill in the Webelos Clan of Akela's tribe. (He call names of boys receiving activity badges, and indicates which badges they earned).

Narrator: Then, Akela was required to pass the highest test of all. He must prove himself qualified to wear his father's name "Arrow of Light"

Akela: From the signs further on down the Webelos trail, I see that the following brave have proven themselves worthy to wear the "Arrow of Light", the highest award in Akela's tribe. (He calls forward boys who have earned the Arrow of Light Award) (upon presenting these awards, the tom-tom begins to beat again at a rapid pace) (Drum stop)

Akela: From the four winds, Akela hears that you braves are doing well along the trails that will lead you into Boy Scouting. Now will all Cub Scouts stand and repeat with me the Cub Scout Promise.

**CLOSING**

Equipment: Flashlight, four candles.

Personnel: Four readers

The room is completely darkened except for the flashlight held by first reader. He passes it on to the next reader, Etc.

1st Reader: "In 1907, when Lord Baden-Powell conducted an experimental camp for boys on Brownsea Island in England, the Scouting movement began as a tiny spark of light." (light 1st candle)

2nd Reader: "On Feb. 8, 1910, then Boy Scouts of America was born when William B. Joyce filed incorporation papers in Washington, D.C." (lights 2nd candle from 1st)

3rd Reader: "On June 1916, The Boy Scouts of America was granted a Federal Charter by Congress. This was also the year when Baden-Powell introduced Wolf Cubbing in Europe. Fourteen years later, Cub Scouting began officially in the United States." (light 3rd candle from 2nd.)

4th Reader: "Just as the light in this room has grown as it was passed from one candle to another, so did the Scouting movement it is the largest youth organization in the world, with more than 13 million members in 110 countries. "let us take this light and let it spread outward to others."

## ARROW PRESENTATION

( Have an arrow painted gold for each boy who is receiving his Webelos badge)

**Cubmaster :** The arrow has always been a symbol in Cub Scouting. It is part of the heritage from the American Indian. A symbol of determination and power. The arrow is straight and narrow like the only path for a Cub Scout. The crooked path like a crooked arrow will never reach its mark.

**Webelos Leader:** The arrow like the space ships of tomorrow are symbols of opportunity and potential. The arrow for those that are willing to work represents fun and adventure while space travel offers an unlimited potential.

**Cubmaster:** Tonight we have several young astronauts of tomorrow that are well on the cosmos way of adventure towards the Arrow of Light award. Will the following Webelos and their parents please come forward and stand by your Webelos Den Leader \_\_\_\_\_.

**Cubmaster:** Webelos, tonight we are presenting to you and your parents a symbolic arrow. This arrow represents a goal, the Arrow of Light award. This joint presentation means it requires effort from both of you. As the challenges of Webelos becomes harder to overcome, let this Arrow and what it represents give you the strength and knowledge to overcome them and reach the goal of the Arrow of Light. Parents into your custody we present your son's arrow to be brought back as a symbol of accomplishment and part of his Arrow of light ceremony in the future. Congratulations.

### CHEERS

#### BOW AND ARROW:

Make motion as if drawing arrow from quiver on back, put it in bow, pull string and say "zing". Do this from start 3 times.

#### WOLF:

Give a Wolf howl four times, each time turning one - quarter of a turn to make one full turn.

#### BEAR:

Growl like a bear and turn one-half a turn each time. Make four growls and two complete turns.

#### CUBBY:

Leaders yells: "What's the best den?", and all the dens answer with their own den number.

## ARROW OF LIGHT CEREMONY

Staging: Arrow of Light Ceremonial Board with seven candles. Parents bring gold arrow with them when they are called up.

Cubmaster: Will the following Webelos Scouts and their parents please come forward, \_\_\_\_\_.

The arrow you have brought with you tonight is now part of your Scouting experience. It represents the straight and narrow path with its many tasks and challenges to your final Cub Scouting goal, the Arrow of Light.

Asst. Cubmaster: While working towards the Arrow of Light this symbolic arrow was there to remind you of your goal. Now that your goal is accomplished it represents not the accomplishment but it is a symbol of the stride, determination and challenges that were met along the way.

Cubmaster: (Pointing to the Arrow of Light Ceremonial Board) "Webelos Scouts, the emblem you see before you represents the Arrow of Light award." "You have completed the four ranks of Cub Scouting - Bobcat, Wolf, Bear, and Webelos - and now have successfully completed the requirements for the Arrow of Light Award. This is the highest rank in Cub Scouting."

Asst. Cubmaster: "The seven candles represent the rays in the Arrow of Light. As they are lighted now, you will hear how they stand for the seven great virtues of life.

(Cubmaster and Asst. Cubmaster take turns)

1. WISDOM - Wisdom does not necessarily mean superior knowledge. It means putting to the right use the knowledge that one possesses.
2. COURAGE - Courage is not the quality that enables men to meet danger without fear, it is being able to meet danger in spite of one's fear.
3. SELF CONTROL - Self control isn't limited to the control of one's temper, but control of one's self in all things; eating, playing, and even working and talking.
4. JUSTICE - Justice is the practice of dealing fairly with others without prejudice or regard to race, color, or creed.
5. FAITH - Faith is the conviction that something unproved by Physical evidence is true. One 8 year old Cub Scout said faith was when you turned the light switch - - you knew the light would go on.



## **ARROW OF LIGHT CEREMONY CON'T**

6. **HOPE** - Hope means to expect with confidence. Always Hope for better things to come. A man without hope is of little good to himself or his community.

7. **LOVE** - There are many kinds of Love - Love of family, Love of home, Love of fellowman, Love of God, and Love of country. All these Loves are necessary for a full life.

**Asst. Cubmaster:** If you live by the seven great virtues you will become a happy man, and a happy man is a successful man.

**Cubmaster:** It is now my pleasure to present you and your parents with your Arrow of Light Award.

Wear this proudly as this is the only Cub Scout rank you will be allowed to wear on your boy Scout uniform. You may also wear it on your uniform if you become an adult Scout leader someday.

**“CONGRATULATIONS!”**

## WEBELOS GRADUATION

**STAGING:** A bridge on stage with the Cubmaster on one end and a Scoutmaster on the other end. Lights dimmed, candles and rank posters displayed.

**CUBMASTER:** Will the Webelos Leader please escort your Webelos and Parents, who have indicated that they are ready and willing to graduate into Boy Scouts, up front to the foot of the graduation bridge, the bridge that connects Cub Scouting to Boy Scouting. (Pause) Webelos, this is the final step in Cub Scouting as a boy and soon the first step in Boy Scouting as a young man.

**ASST. CUBMASTER:** I know I can speak for our pack and its leadership that we are indeed proud of your accomplishments over the past year. Your Webelos leader has guided and taught you as well as learned from you over the past year. Only your parents can be more proud of you than these leaders.

**CUBMASTER:** We, the leaders of Pack \_\_\_\_\_ wish you luck and success on this new trail of Scouting. I am sure that if you put as much time and effort in the days ahead as in the days past, you will be successful no matter what you do, in Scouting or in any other part of your life.

**ASST.: CUBMASTER:** Will the parents of the graduating Webelos please take your place by Mr. \_\_\_\_\_, the Scoutmaster of Troop \_\_\_\_\_. (As each Webelos name is called the Webelos Leader will escort his Webelos to the bridge to Boy Scouting) The Webelos Leader will remove his Webelos neckerchief - award him his Graduation certificate. Each Webelos in turn will step up on the bridge, take three steps to the middle of the bridge, salute the new Scoutmaster, and continue across the bridge. While this is happening, the Cubmaster may read aloud the Scout oath in three parts as each Webelos crossed over.

( The Scout Law may be read in parts too, depending on number of boys.)

**SCOUTMASTER:** (Give the Scout handshake to each graduating Scout, welcomes him to the troop and places the troop neckerchief on his neck. After all the scouts have crossed over and been welcomed.) Scouts, we are happy to welcome you to our troop. I can see by the Arrow of Light that you are prepared to join the great fellowship of Scouting. As a Scout you will be given many opportunities for learning, leading, and having fun. We only ask that you try your best. Please repeat after me the Scout oath. (Scouts repeat the oath.) Parents - welcome to our troop. I congratulate you on the fine work that you have done with your son in Cub Scouting. I am sure you will find new adventures in our troop.

## **BLUE AND GOLD BANQUET GRACES**

The invocation or grace for the Blue and Gold banquet should be conducive to reverence. It should not offend anyone's religious beliefs. Here are a few suggested graces:

Bless us, O Lord, and these Your gifts Which we are about to receive from your Bounty. Amen.

We give You thanks, Almighty God, for all your benefits. Bless this food to the nourishment of our bodies and our lives to Your service. Amen.

For health and strength and daily food, we give You thanks, O Lord,  
For food and health and friendship, we give You thanks, O Lord.

Gracious giver of all good, we thank you for rest and food.  
Grant that all we do or say be in your service, this day Amen.

Teach us, Dear God, to work together in cooperation and understanding.  
Open our eyes to the opportunities of our job. Inspire our thoughts, our words, and deeds, that they may help our Cub Scouts to know You better. Amen.

Heavenly Father, we ask Thy blessings upon these Cub Scouts,  
counsel them with Thy wisdom: strengthen them to stand for the  
hard right against the easy wrong; inspire them with high  
purposes and keep them always ready to perform kind deeds.  
Bless this food to our use, and us to Thy service, and keep us  
ever mindful of the needs of others. Amen.

## MOWGLI JOINS THE JUNGLE PACK

Here is a short skit based on Rudyard Kipling's *The Jungle Book*. If desired, participants may wear wolf, bear, lion masks, etc.

**Personnel:** Akela on stage in kneeling position; Mother Wolf kneeling on Akela right; Mowgli sitting with crossed legs facing Akela; Shere Khan, the tiger; Baloo, the bear; The panther; Narrator. Cub Scouts may form pack council in circle around Akela.

**Narrator:** Kipling's jungle stories as adapted by Lord Baden-Powell of England, who started the Scout movement, have been made the basis of the Cub Scout program in 65 different countries. We have taken our skit from Rudyard Kipling's *The Jungle Book*. As our scene opens, Mowgli, the man cub, has been brought before the pack council. Shere Kahn, the vicious tiger, wants to kill the cub, but Mother Wolf wants to keep the cub as her own. Akela, the great lone Wolf who leads the pack, arises from his rock.

**AKELA;** Ye know the law -- ye know the law. Look well, oh wolves.

**Mother Wolf;** Look, look well, oh wolves. ( enter Shere Kahn from right.)

**Shere Kahn;** He is mine! Give him to me!

**Narrator:** Now the law of the jungle lays down that, if there is any dispute as to the right of a cub to be accepted by the pack, he must be spoken for by at least two members of the pack neither of whom is his mother or father.

**Akela;** Who speaks for this cub?

**Narrator;** The only outside creature who is allowed at the wolf pack council is Baloo, the brown bear, who teaches the wolf cub the law of the jungle. (Enter Baloo from left)

**Baloo;** I speak for the man cub. There is no harm in him. Let him run with the pack. I myself will teach him.

**Akela;** Baloo has spoken and he is our teacher for the young cubs. Who speaks besides Baloo?

**Narrator;** A shadow drops into the circle. It is Bagheera, the king of the jungle and nobody cares to cross his path. (enter Bagheera from left).

**Bagheera;** To kill a small cub is shame! To Baloo's words, I shall add my strength and help this small cub.

**Narrator;** And this is how Mowgli joined the Seeonee Wolf Pack.

**DOORWAY TO ADVENTURE**  
(Tune: On top of Old Smokey)

On top of the mountain  
I can look to the sea  
Through the doorways to adventure  
That are open to me!  
I can see Davey Crocket  
And Neil Armstrong, too.  
The adventures are colored  
In Gold and Blue.  
In Gold and Blue means  
It's for me and for you.  
The doorway to Adventure  
Are for us to go through!

**BLESS OUR CUB SCOUTS**  
(Tune: O Tannenbaum)

Bless our Cub Scouts, Lord we pry,  
Keep them healthy, all the day.  
Let them know, their Cub Scout sign,  
Have it always on their minds.

If they do, we promise them,  
They'll become goo future men.  
Hear their prayers at night and day.  
Guide them, Lord, along the way.

**CUB SCOUT HARMONY**  
(Tune: I'd like to Teach The World To Sing)

I'd like to teach the world to sing in Cub  
Scout harmony,  
The Blue and Gold would be the thing, that  
everyone would see.  
Each Wolf and Bear and We-be-lo, is doing  
all he can.  
To do his best, with all the rest,  
Of Cub Scouts in the land.

**RECOGNITION SONG**  
(Tune: Farmer in the Dell)

Our honored guests are here,  
Our honored guests are here,  
Stand up now and take a bow,  
Our honored guests are here.

NEXT VERSES: Den Leaders, Webelos  
Leaders, Parents, Den Chiefs, Brothers,  
Sisters, Cub Scouts, etc.

**BLUE AND GOLD**  
(Tune: O Tannenbaum)

O blue and Gold, O Blue and Gold,  
You know it stands for truth untold.  
O Blue and Gold, O Blue and Gold,  
The youth that wear you aren't so old.

So carry on your colors bright,  
Until the whole world you will light.  
O Blue and Gold, O Blue and Gold,  
The memories live, while we grow old.

**BLUE AND GOLD TRADITION**  
(Tune: Jingle Bells)

While dashing all around to prepare for Blue  
and Gold,  
They boys made napkin rings and placements  
to behold.  
The nut cups they were neat. The name tags  
were just right.  
Oh, what fun it is to have a Blue and Gold  
tonight.

Chorus:  
Blue and Gold, Blue and Gold,  
Banquet time again.  
Families gathered all around,  
Ready to pitch in.

Fried chicken and baked beans, potato salad,  
too.  
A piece of birthday cake enough for me and  
you.  
Some people ate too much, but we all  
enjoyed the meal.  
The friendship that we shared was warm and  
true and real.



WOLF CUB 1

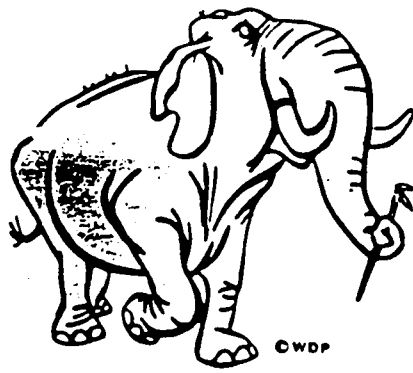

COL HATHI

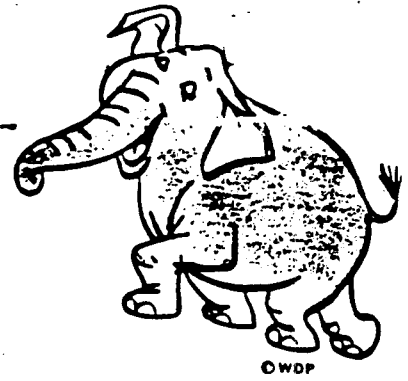

WINIFRED



WOLF CUB 2

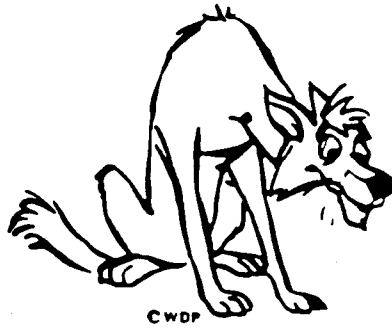

FATHER WOLF



FLAPS



ZIGGY



SHERE KHAN



RED HEAD

**MARCH**

**GATEWAY TO THE  
ORIENT**

## **SCOUTING AROUND THE WORLD OPENING**

(World brotherhood)

Cubmaster and three volunteers with cards that say: LOVE, HOPE, PEACE. A USA flag

**VOL 1:** (Hold up LOVE card) Brotherhood is LOVE. What greater love could exist than the love of GOD for mankind; the love of man throughout the world is shown through caring and helping one another.

**VOL 2:** (Hold up HOPE card) Brotherhood is HOPE. Hope becomes a reality when we live by the Cub Scout Promise and Law of the Pack.

**VOL 3:** (Hold up PEACE card) Brotherhood is PEACE/ Peace on earth and Goodwill to all men, women, and children of the World.

**Cubmaster:** We the Cub Scouts around the world support LOVE - HOPE - PEACE Year around - world around. Please stand to say with me the pledge of allegiance. May this flag forever stand for freedom and peace and may the USA forever be a leader in World Brotherhood. Attention. Pledge .....

## **SCOUTING AROUND THE WORLD CLOSING**

Cubmaster and four or more volunteers with candles and various country flags. If the dens used various countries for their den themes use one per den from that specific country. (lights out)

**Cubmaster:** (light candle) This candle represents the Spirit of Cub Scouting. We came here tonight to celebrate the founding of Cub Scouting. We remember the cubs of the past, honor the cubs of the present, and look forward to the hopes and aspirations of the cubs of the future. Cub Scouting is a part, an important part, of the light of Scouting around the world.

**VOL 1:** (light candle) Scouting in America ( come forward and place flag in holder)

**VOL 2:** (light candle) Scouting in Japan (come forward and place flag in holder)

**VOL 3:** (light candle) Scouting in China (come forward and place flag in holder)

**VOL 4:** (light candle) Scouting in Korea (come forward and place in holder)

**Cubmaster:** Yes, truly the light shines in over 116 countries around the world. This light shines, is shared and grows with every new boy that takes the first step to adventure and becomes part of scouting around the world. And now may the master of all scouts be with us until we meet again. Good night and good scouting.

MARCH 1



## GAMES

### FISHTAIL

Description of Game: Players form up in single file - each one grasping the waist of the player ahead.

The last player has a fishtail tucked into the back of his belt (A neckerchief works well)

The fishes head tries to maneuver so that he can snatch the tail while the player with the tail tries to prevent it.

After a few minutes, another two players change places with the head and tail.

Caution: Make sure that the area is clear of obstructions.

SPACE REQUIRED: Hall of defined area outdoors. EQUIPMENT REQUIRED: None

### CROSSING THE RICE FIELDS (CHINA)

Divide dens into two teams. Have each team break into two-boy teams. When the leader calls, "RICE!" the first pair on each team forms a "wheelbarrow" (one boy walks on his hands while the other boy holds his ankles) and races across the "rice field" to a "river" (two parallel ropes on the floor). At the edge of the river, one player climbs on the other's back and is carried piggyback across the river. On the other bank, they change places for the return trip across the river an then wheelbarrow back to their team. The next pair then starts.

### CHEERS

Chinese Cheer: How, How, How  
Phooey, Phooey, Phooey

Fish cheer: How, How, How,  
Flop, Flop, Flop  
(flip - flop motion with hands)

## SONGS

### **MY AUNT CAME BACK**

(Tune: How dry I am)

(Echo song)

My Aunt came back... from old Japan...

She brought to me... an old silk fan...

(fan with hand)

My Aunt came back... from old Algiers...

She brought to me... a pair of shears... (cut with fingers)

My Aunt came back... from Holland

too...

She brought with her... a wooden shoe...

(stomp with foot)

My Aunt came back... from Kalamazoo...

She brought for me... some gum to chew...

(chew)

My Aunt came back... from old Hong Kong

...

She brought for me... the game ping pong ...

(move head side to side)

My Aunt came back... from the Knoxville

Fair ...

She brought for me ... a rocking chair ...

(rock back & forth)

My Aunt came back ... from a Scout meeting

too...

She brought for me ... some nuts like you!!!

### HE'S GOT THE WHOLE WORLD IN HIS HANDS

He's got the whole world in His hands

He's got the whole world in His hands

He's got the whole world in His hands

He's got the whole world in His hands

He's got the little bitty Tigers in His hands.

He's got the running Wolfs in His hands

He's got the big bad Bears in His hands.

He's got the crazy Webelos in His hands

### IT'S A CUB WORLD

(Tune: It's a Small World)

There are Cub Scouts in England and Italy,

There are Cub Scouts in Japan and China,

When the Cub flag's unfurled,

All around this big world,

It's for Cubs like you and me.

Chorus:

It's Cub World after all, It's a Cub World after all;

It's a Cub world after all, It's a Cub Scout World.

There are bears and Wolves and Webelos

We wear different patches and different clothes,

But I tell you, it's true,

We all wear gold and blue,

In our Cub World, after all.

Chorus

Akela guides us all, you see,

To learn and do and grow and be,

And we all meet the test,

"Cause we all DO OUR BEST,

In our Cub World after all.

Chorus

### KUM BA YAH

Kum ba yah, my Lord, Kum ba yah!

Kum ba yah, my Lord, Kum ba yah!

Kum ba yah, my Lord, Kum ba yah!

O Lord, Kum ba yah!

Someone's crying Lord, Kum ba yah...

Someone's praying Lord, Kum ba yah ...

Someone's singing Lord, Kum ba yah ...

Someone's scouting Lord, Kum ba yah ....

MARCH 3

## THE MAGIC KITE

CHARACTERS: 6 boy

PROPS: Outside scene, ball of string and kite tail.

SETTING: Boy holding a ball of string with a kite tail on one end. Five other boys gathered around.

1st Cub: What's that?

2nd Cub: Don't you know what a kite looks like?

1st Cub: Sure I do, but if that's a kite, then it sure won't fly

2nd Cub: It'll fly, it's magic!

3rd Cub: Kites can't be magic!

2nd Cub: This one is. All I have to do is say, "Dad, look at the kite I've made."

4th Cub: Then what!

2nd Cub: He shows me how to make one.

5th Cub: That kite still won't be magic!

2nd Cub: Un huh! Then he shows me how to fly it.

6th Cub: Wow! It's magic if it can do all that. Come on, guys, let's make one.

(All boys going off stage saying "Yeah", "Wow". "It is magic", "Let's Go".)

## SKIT WITH KITES

Cub Scouts hold kites they have made.

1st Cub: March is the month for flying kites. Always use dry string not wire or anything metal.

2nd Cub: Always avoid busy streets and highways when flying your kite.

3rd Cub: Fly your kite far from TV and radio antennas.

4th Cub: Always fly your kite far from electric or telephone lines.

5th Cub: Call your Power company if the Kite gets caught in lines. Do not pull the string.

6th Cub: Keep away from fallen wires and don't climb power poles.

7th Cub: Remember, the kite you save may be your own.

## WEATHER ROCK

Bet this will really floor mom and dad. A really different weather forecaster, but just about as accurate as the highly paid ones.

Cut three 36" lengths of twine or jute. Fold the strands in half and form a loop about 2" down from the top, as shown. Cut a short piece of jute and tie under the loop.

Braid the six strands together about another 8" down from the loop. Now, place a large, smooth rock within the jute and knot to hold. Continue braiding about another 3" and then knot, leaving about 2" for the end tassel.

On a white index card write the message below. Cover the front and back of the card with clear adhesive paper. Glue the card to the rope, below the loop.

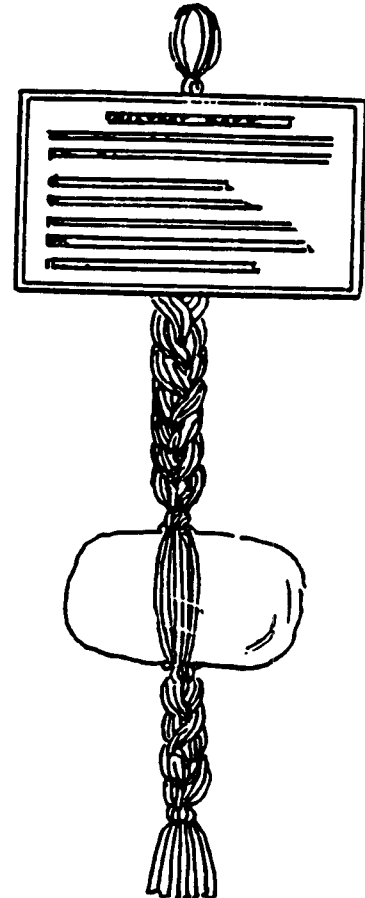

## WEATHER ROCK

Your local weather forecaster is not always 100% correct!  
This rock is a perfect Weather Indicator--always 100% accurate!

A dry rock - fair weather.  
A wet rock - rainy weather.  
A dusty rock - polluted air.  
A swaying rock - wind is blowing.  
A disappearing rock - fog has rolled in.  
Rock jumping up & down - an earthquake.  
Rock is white - snowing.  
Rock is wet and sun is shining - that darn dog!

March 5

# Jumping Frog

(an origami project)

NEED: one 3" x 5" index card for each frog; construction paper works but not as well.

## DIRECTIONS:

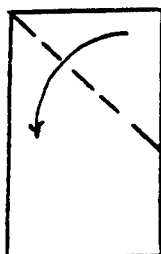

1. Fold down right top corner.

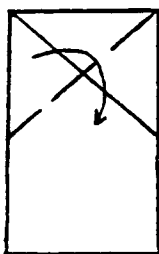

2. Unfold.

3. Fold down left corner.

4. Unfold.

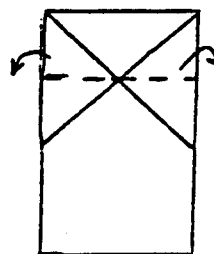

5. Fold backward as shown by broken line, where lines cross.

6. Unfold.

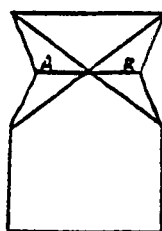

7. Push down at "x". Bring sides A and B to meet in middle. See next drawing.

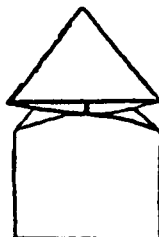

8. Push down top triangle and crease sharply.



9. Fold outer points up as shown.

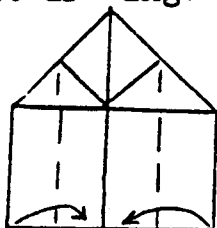

10. Fold sides of card to the center.



11. Fold model in half by bringing bottom edge up to the top.

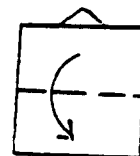

12. Fold down top layer only in direction of arrow.

13. Stroke back of frog to make him jump.

Have races in the den. Have fun!

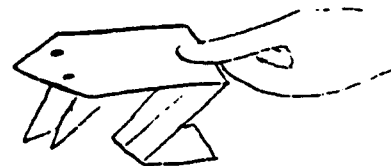

March 8

# Solar New Year in Southeast Asia

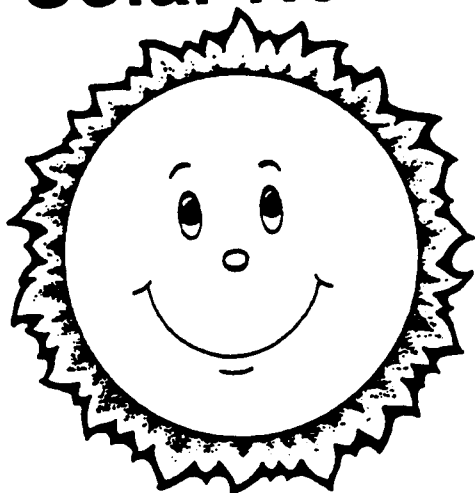

April 13 or 14

<i>Songkran:</i>	Thailand
<i>Bun-Pi-Mai-Lao:</i>	Laos
<i>Thingyan:</i>	Burma
<i>Bon Chol Chhnam:</i>	Kampuchea (Cambodia)
<i>Baisakhi:</i>	Sri Lanka
<i>Baisakhi:</i>	Bangladesh
<i>Baisakhi:</i>	India

Most of Southeast Asia celebrates the Solar New Year by one name or another. Most of the festivals involve water since this is the hottest time of the year in these countries. The water that is thrown by the bucketful at everybody is intended to bless them and to wash off the troubles of the old year.

There are many other New Year's rituals to be observed, also. Houses are cleaned, new fires are kindled, old wrongs are righted, new clothes are worn, gifts are exchanged, and special foods are prepared and eaten. The images of Buddha in the temples are ceremonially washed with a mixture of perfumed water and flower petals.

Outside of Southeast Asia, people from each of these countries adapt their celebrations to new conditions. Most of them gather in public places like colleges and community recreation centers where there will be room for everybody. Their main purpose in celebrating the New Year is to pass on their culture to their children. A secondary, but still important purpose, is to refresh themselves with a breath of home in a strange land. Adults and children alike are mesmerized by the dances, the music, and the smells of traditional foods.

## Making It Work

Check newspapers (or ask students to check) for announcements of Solar New Year celebrations in your area. Remember, there may be variations in the spelling of the names of these festivals in the newspapers. Keep parents informed by sending home a class newsletter with this kind of information.

Ask students to share with the class first-hand reports of celebrations they attend. Where was the festival they attended? Which ethnic, national, or religious group put it on? Did they attend as a family? What did they see? Hear? Do? Eat?

# Making a Japanese Carp Kite

## Materials:

- large paper cup (plain or waxed)
- markers or crayons
- colored paper
- crepe paper for streamers
- glue or stapler
- string

## Directions:

1. Draw the head of a carp on the paper cup, or design the head of a carp using colored paper and attach it to a paper cup. Include eyes and mouth. (The mouth should be near the bottom of the cup.) Use any colors that you like.

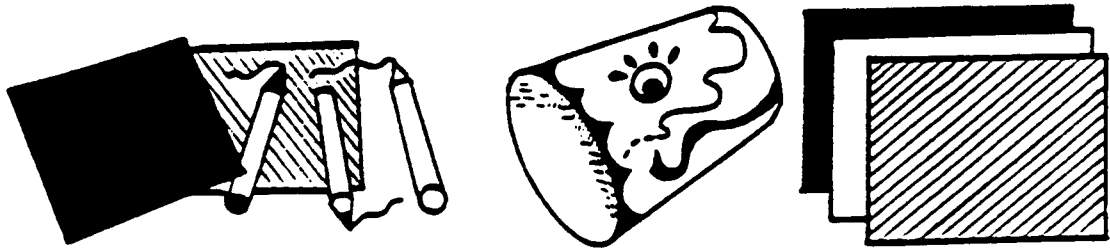

2. Cut a dozen streamers from crepe paper. Glue or staple them to the open end of the cup.

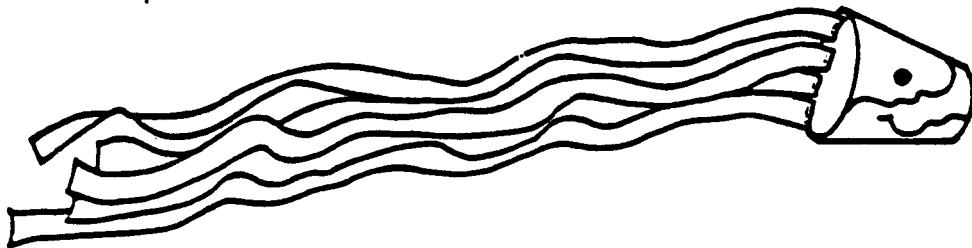

3. Poke four tiny holes around the bottom of the cup as shown.

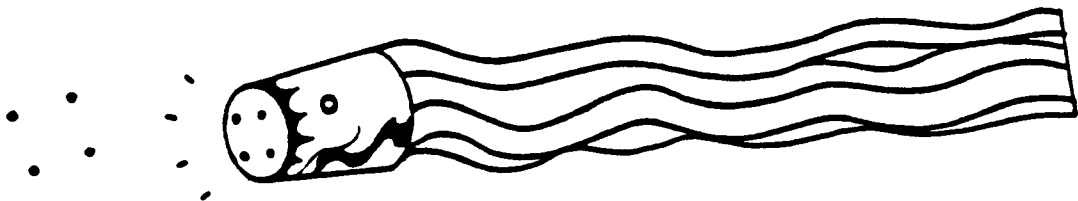

4. Cut four 12" pieces of string, and make a knot in one end of each. Pull the strings through the four holes in the cup from the inside out. Tie the four ends together to make the kite's bridle. Attach a longer string to the bridle to hold.

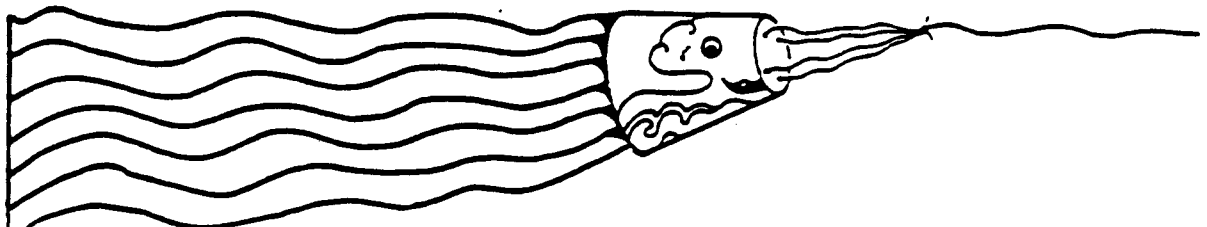

**APRIL**

**POLLUTION SOLUTION**



## FOUR WINDS OPENING CEREMONY

4 Cub Scouts dressed in Indian costumes (not necessary), carry artificial torches. Artificial campfire which can be lighted bulb inside the campfire and the bulb is covered with red cellophane.

Cubmaster: Let the North Wind enter.

One of the Cub Scouts enter carrying torch. He stands by fire and says his line. Others do likewise as they are called in.

North Wind: The North wind that brings the cold, builds endurance.

Cubmaster: South Wind, enter.

South Wind: The South wind brings the warmth of friendship.

Cubmaster: East Wind, enter.

East Wind : The East Wind brings the light of day.

Cubmaster: West Wind, enter.

West Wind: The West Wind from the direction where the sun sets, brings night and stars.

Cubmaster: The Four Winds will light our council fire.

All four Cub Scouts touch their artificial torches to fire at the same time. At this same moment, electrical cord is connected off stage, lighting up the bulb and the council fire.

## TO OUR FATHER - CLOSING

To our Father above, who has given us so many blessings. To our mother earth who has given us rich harvests. To the North Wind with its cold breath of winter that gives us endurance. To the East Wind from the land of the rising sun, sending morning light across the plains. To the South Wind and the warm sunshine. To the West Wind from the land of the tall mountains. I now declare this pack meeting closed.

APRIL 1

## TREE ADVANCEMENT

**PROPS:** A large tree, cut from cardboard and set firmly in a stand. Large green construction paper leaf for each boy who will receive award.

**CUBMASTER:** This tree is a symbol of the natural beauty of our land. It takes Mother Nature a long time to grow a beautiful tree. It requires sunshine and water and care. This tree represents our Cub Scout Pack. In order for it to grow and flourish, much time and effort must be spent by Cub Scouts and their parents. The boys receiving awards tonight have given time and effort, as have their parents. As each of you receive your award, you will place a leaf on our tree, and you will be able to see how much more attractive it is because of you.

(Call forward boys and parents receiving awards. Have each tape a leaf on the tree. The leaves could have the boys' names on them)

You have all helped make this tree more beautiful, and it is a part of you. Just as Mother Nature's trees endure for many years, you have learned many things from your achievements, electives and activity badges that will last you a lifetime. May you always stand tall and straight like a tree and be a worth while resource of our country.

### A DAY

(CLOSING THOUGHT FOR PACK CLOSING)

What is the gift you will give your boy?  
A glamorous game, a tinsel toy,  
A whittling knife, a puzzle pack,  
A train that runs on a gurgling track?  
A Boy Scout book, a real live pet?  
No, there's plenty of time for such things yet.  
Give him a day for his very own --  
Just your boy and his dad alone.  
A walk in the woods, a game in the park,  
A fishing trip from dawn to dark;  
Give him the gift that only you can --  
The companionship of his "old Man",  
Games are outgrown, and toys decay,  
But he'll never forget if you give him a day!

APRIL 2

## **CLOSING**

- Materials:** One copy of Outdoor Code for each person
- Setting:** A den of Cub Scouts leads the reading of the code. Perhaps a pair of boys reading each "leader" section.
- Leader:** As an American, I will do by best to be clean in my outdoor manners.
- Pack :** I will treat the outdoors as a heritage to be improved for our greater enjoyment. I will keep my trash and garbage out of America's waters, fields, woods and roadways.
- Leader:** Be careful with fire -
- Pack :** I will prevent wildfires. I will build my fire in a safe place and be sure it is out before I leave.
- Leader:** Be considerate in the outdoors -
- Pack :** I will treat public and private property with respect. I will remember that use of the outdoors is a privilege I can lose by abuse.
- Leader:** Be conservation - minded -
- Pack :** I will learn how to practice good conservation of soil, waters, forests, minerals, grasslands, and wildlife; and I will urge others to do the same. I will use sportsmanlike methods in my outdoor activities.

## **HIKING GAMES**

**ONCE AROUND THE BLOCK:** Hikers go 'once around the block then their observations are tested. who has seen the most round things? What kinds of trees were seen?

**NIGHT HIKE:** In areas where it is safe to go walking at night, try a hike after dark. Flashlights may be carried. See how different things look, smell and sound at night. Being out in the unfamiliar dark is an adventure in itself.

**BIG GAME HUNT:** See how many different animals you can find. Decide ahead of time if birds and insects are to be included. boys will learn to identify different species.

**STRING ALONG:** Take a piece of string about a yard long on your hike. Every now and then, place the string in a circle on the ground. See how many different things you can find enclosed within the circle. You may be in for a surprise, for it is not unusual to find 20 or more things! Now stretch a string in a line. See how many different things touch it.

## SONG

### THE COMING OF THE FROGS

Tune: The battle Hymn of the Republic

Mine eyes have seen the horror of the  
coming of the frogs,  
They are sneaking through the swamps,  
they are lurking in the logs.  
You can hear their mournful croaking  
through the early morning fog.  
The frogs keep hopping on!

CHORUS: Ribit, ribit, ribit, croak ,  
croak.  
Ribit, ribit, ribit, croak,  
croak.  
Ribit, ribit, ribit, croak,  
croak.  
The frogs keep hopping on!

The frogs have grown in numbers and  
their croaking fills the air,  
There's no place to escape to, 'cause the  
frogs are everywhere.  
They've eaten all the flies, and now  
they're hungry as a bear.  
The frogs keep hopping on!

CHORUS:  
I used to like the bullfrogs, like to feel  
their slimy skin,  
Like to put them in teacher's desk and  
bring them to our den.  
Now they're knocking at the front door,  
I can't let those frogs come in!  
The frogs keep hopping on!

CHORUS:  
They have hopped into the living room  
and headed down the hall.  
They have trapped me in the corner and  
my back's against the wall.  
And when I open my mouth to give a  
warning call,  
This was all I heard.....  
CHORUS:

## BUG JUICE

(Tune: On Top of Old Smokey)

At Camp Grice Scout Camp, They gave  
us a drink,  
We thought it was Kool-Aid, Because it  
was pink.

But the thing that they told us, Would've  
grossed out a moose.  
For the great tasting pink drink, was  
really Bug Juice!

It looked fresh and fruity, Like tastey  
Kool-Aid.  
But the bugs that are in it, Were  
murdered with Raid.

We drank it by the gallons, We drank it  
by tons.  
And the next morning, We all had the  
runs.

So next time you drink Bug Juice, And a  
fly drives you mad,

He's just getting even, 'Cause you  
swallowed his Dad!

### TELL ME WHY

Tell me why the bugs do bite,  
Tell me why the campfire won't light  
Tell me why our tent fell down,  
Tell me why we sleep on the ground.

Because they're hungry, the bugs do  
bite!  
Because the wood's wet, the campfire  
won't light!  
Because we're lazy, our tent fell down!  
Because we're Cub Scouts, we sleep on  
the ground!

## MAGIC MUD

**Characters:** Six Cub Scout in summer uniforms or Cub Scouts T-shirts

**Setting:** Sign in center of stage marked MUD PUDDLE. Boys are gathered around this sign as the curtain opens.

**NARRATOR:** Did you ever wonder as you pass a little stretch of mud and grass what nature may be hiding there, within this spot a few feet square? Boys, gather round and take a look, and like the pages in a book, we'll study it with open eyes. Can soil like this hold a surprise?

(Boy's knell in circle around mud puddle. add desired props.)

#1: Here's a freshly patterned animal track where a rabbit hopped across and back.

#2: I see a stream of busy ants, carry tidbits as they dance.

#3: Look, a feather blue and gray dropped off by a screaming Jay.

#4: Sprinkled here are sprouting seeds from lofty elms and sprawling weeds.

#5: A pebble smoothed by action slow, formed a million years ago.

#6: In a puddle spot, not yet dried out, a water beetle swim about.

#1: And here an eager plant is set - an early blooming violet.

#2: A wiggly worm comes up to twitch; no one knows which end is which.

#3: The mud itself, with food stores vast, from life that grew in ages past.

#4: It's not all nature mud reveals: here's a candy wrapper and two toy wheels.

#5: There's something moving - what's that now? I'll pick it up - a bee - YOW!

#6: Quick, here's some mud to put upon the spot, to take away the soreness hot.

**NARRATOR:** In mud there are stones and living things: healing power for bitter stings. through it flows the earth's life blood. Our soil in the neighborhood is really MAGIC MUD.

APRIL 5

## Keep America Beautiful

(flower & grass wave gently in breeze. LITTERBUG stands at left, laughing and throwing soda can on flower - bottle on flower, candy wrapper on grass)

Flower: Oh, What hit me? My petals are crushed. My upsweep is down swept.

Grass: You should complain. They buried me.

Soda Can: You think I like being thrown around? I could be used for a tin craft by some Den Leader.

Bottle: Does the Philmont Staff realize my potentiality? I could be used as a puppet or trick.

Litterbug: (laughs) I love a Dirty America everyday ---- UGLY, UGLY, UGLY.

Candy Wrapper: Just look at me. I was meant to be so sweet and bring such a lot of happiness.

Cub Scout: (sees litter-trash can sleeping) Wake up trash can, Litterbug was here.

Trash Can: Help, Help, you'd think I was a Segoe girl. No more than they are feeding me. All I ever do is wait. I've tried everything. I've even flipped my lid.

Cub Scout: People have got to realize this is one bug RAID won't kill. Only consideration by others will get rid of this pest. I'll start helping right now to eliminate that old LITTERBUG!

LITTERBUG; Foiled Again! (Cub picks up trash).

Flower: (sigh) What a relief! I thought you'd never come.

Cub Scout: Every Cub is honor bound to help KEEP AMERICA BEAUTIFUL!

Grass; Adults help the Litterbug so much - are they too old to be Cubs?

Cub Scout: No one is either too old or too young to do their share in keeping AMERICA BEAUTIFUL. This is the duty and privilege of every American.

APRIL 6

## WALKING WALNUT ANIMALS

These walnut animals can scamper quickly down a smooth slope -- the turtle moves as fast as the mouse.

Halves of walnut shells are used for the bodies with bits of felt attached for head, feet and tail.

The mouse whiskers are pieces of straw from a broom or thin thread stiffened with white glue.

Use white glue for attaching all decorations.

Use magic marker pen for eyes.

When the animals are finished, put a marble under each one and watch them scramble down a slanting book or board.

### SUPPLIES:

Walnut shell halves

Felt

Straw from a broom or thread

white glue

Marbles

Slanting race board (propped up book, cardboard or piece of wood)

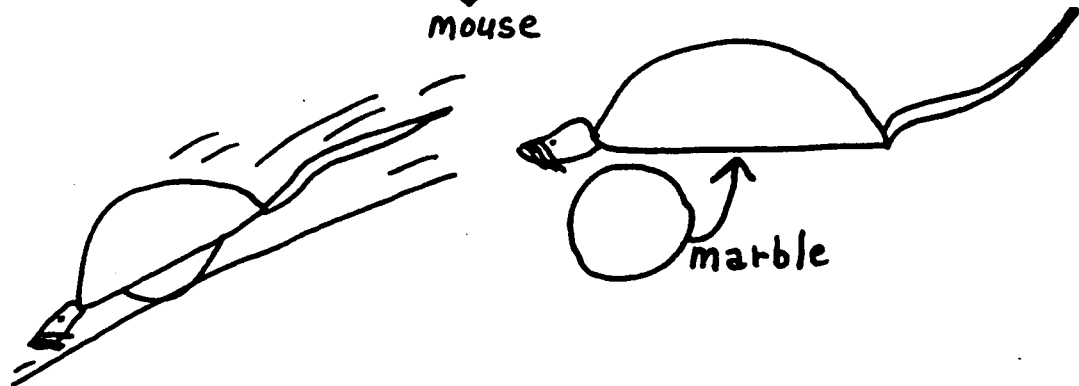
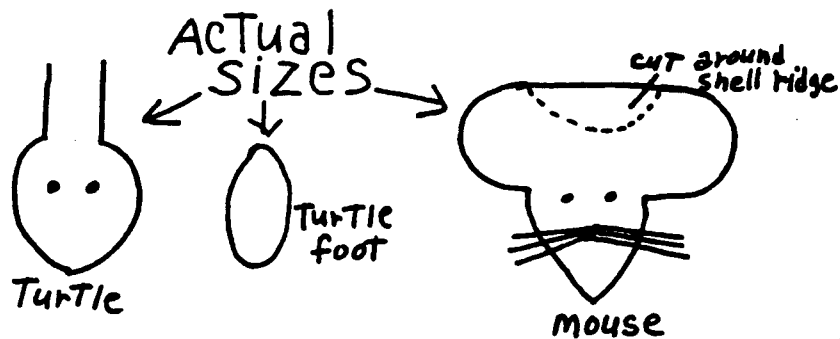
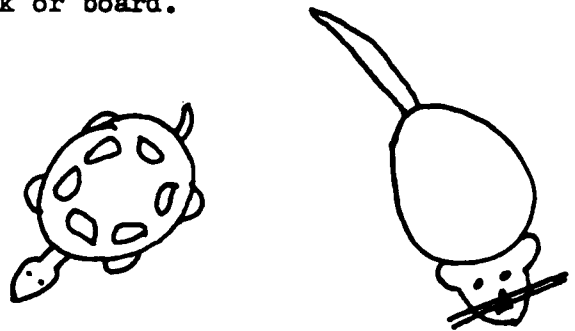

April 5

**MAY**

**LEGENDS AND LORE**



## **OPENING CEREMONY**

Have the Cubmaster dressed as a pioneer cook.

Setting: On stage is a large kettle made from a cardboard carton. There is a short step ladder at each side for the boys to climb up to get into the kettle. Put pad on the other side for the boys to land on. As curtain opens the Cubmaster and assistant enter, holding a large piece of paper that says "RECIPE" in large letters.

Den Leader: What are you making?

Cook: This is a Cub Scout stew. Would you like to watch?

Den Leader: Yes, I would. What goes into it?

Cook: (pretend to read the recipe) First add any number of Cub Scouts who do their best. (Uniformed Scouts come onto stage and climb into the pot)  
Then add a sense of humor. (Grinning cub Scout with a sign HUMOR)  
Next, add a pinch of service to others (Cub with sign SERVICE climbs in)  
Then add a dash of mischief (Cub with sign MISCHIEF)  
And a big helping of sunshine (Cub with sign SUNSHINE climbs in)  
And last, add a ton of energy! (Cub wearing ENERGY climbs in)  
Cook pretends to stir well, and you have a Cub Scout Stew.

Den Leader: That's delicious! I'd like your recipe.

Cook hands recipe to leader and invites everyone to join in the Pledge of Allegiance and Cub Scout Promise.

## **CLOSING**

### **CUB SCOUT PRAYER**

Lord, in this evening hear I pray  
For strength to do my best each day.  
Draw near to me that I may see  
The kind of Cub that I should be.

In serving others, let me see  
That I am only serving Thee.  
Bless me, Oh Lord, in Thy great love,  
that I may be better Cub.

### **THE SCOUT BENEDECTION**

And now, may the Great Master of all Scouts, be with you until we meet again.

**PONY EXPRESS TRAIL**  
(Advancement Ceremony)

Props: Long rope with Bobcat, Wolf, Bear, and Webelos stations laid out at appropriate points on the rope. Tom-tom, Electric campfire, Spotlight if lights are out.

CUBMASTER: This month's theme is \_\_\_\_\_. In tonight's ceremony all Cub Scouts will pretend to be Pony Express riders and parent will be Station Attendants. (Den Chief beats tom-tom to rhythm of a galloping horse.)

ASST. CUBMASTER: Will all pony express riders gather around the campfire. It is time for us to take council.

CUBMASTER: The bobcat is starting the trail of scouting as he learns the ideals of Cub Scouting - the Cub Scout motto as well as the sign, the handclasp and the salute. It's a long trail ahead to the Eagle rank, but this is the beginning. Just as the pony express rider started his long ride, so our new Bobcats are starting out tonight. Will the following boys line up at the starting gate on the pony express trail?

(Advancement Chairperson reads off the names of boys who are ready for their Bobcat rank. Den Chief beats tom-tom lightly as boys go to starting gate.)

ASST. CUBMASTER: When the Bobcat requirements are accomplished, the young Bobcat is ready to begin his journey along the pony express trail of Scouting where each achievement is a milepost. There are 12 mileposts between each station.

CUBMASTER: Just as the pony express rider galloped along the trail defying the dangers and hazards of the wilderness from one station to the next, so the young Bobcat express rider begins his gallop along the trail to Wolf Valley Station.

Advancement Chairperson: Tonight we have (boy's names) who have galloped the 12 miles to Wolf Valley Station.

(Den Chief beats tom-tom lightly.)

Advancement Chairperson: (boy's names) Have galloped another 12 miles to Bear Ridge Station. Will these boys please go to Bear Ridge Station.

(Den Chief beats tom-tom lightly.)

Advancement Chairperson: (Boy's names) have made the long trip to Webelos Lodge Station. Will these boys please go to that station.

## PONY EXPRESS TRAIL CON'T

(Den Chief beats tom-tom lightly.)

**CUBMASTER:** Will the station attendants (parents) of these brave riders please come forward so that they may receive the awards to present to their boys.

(Awards are presented at each station, in turn, by Advancement Chairperson while the Asst. Cubmaster reads awards: Bobcat, Wolf, Bear )

**ASST. CUBMASTER:** In addition to the 12 mileposts between stations (Boy's names) have scouted (number of miles - arrow points) - elective mile posts above and beyond the call of duty.

(Advancement Chairperson awards arrow points. After all other awards are presented the Webelos Induction and Presentation Ceremony takes place.)

**CUBMASTER:** This station represents the plateau of Cub Scouting. These boys have been on the trail under the guidance of a Den Leader. the Webelos Scout is instructed in, and learns the requirements which enable him to continue his journey up the trail into Boy Scouting.

(Advancement Chairperson presents Webelos Award to parents to pin on their sons.)

**CUBMASTER:** I would like to congratulate all these fine riders and station attendants for advancing along the pony express trail. As you learn, you advance; and as you advance, you grow.

### GAMES

**WHAT PIONEER AM I?** Pin the name of an American Pioneer on the back of each player. (He does not see the name.) In turn, each player tries to guess his pioneer. (the others give him hints until he guesses correctly.)

**HUNT THE COON.** Any small object, such as a block or small animal, may be used as the coon. All cover their eyes and " No Fair Peeking" while the man who is "it" hides the object somewhere in the room where it is in plain sight but not readily seen. Then he says " Hunt the Coon" and all begin the search. As soon as a player sees the coon he says nothing, but quietly sits down. One by one the players will sit down until only one is left.

## CITY SLICKERS

**Cast:** Ma, Pa, Boy, Sis, all dressed as hillbillies. Two boys dressed as city slickers.

**Props:** Large cardboard car cutout with handles on back. A log cabin prop or backdrop.

**Setting:** Two city slickers drive up in front of log cabin and honk their horn.

**MA:** (Comes out of cabin) Howdy! What Ya'll want?

**Driver:** How do we get to Tulsa?

**Ma:** Well... I don't rightly know, but I'll ask my son. (Yells into cabin) Sonny, How do ya'll get to Tulsey?

**Boy:** (comes out) Well, Ma. I don't rightly know. I'll ask Sis. (Yells into cabin) Sis, how do ya'll get to Tulsey?

**Sis:** (comes out) I don't rightly know. I'll ask Pa. (Yells) Pa, how do ya'll get to Tulsey?

**Pa:** (comes out) Let me see now. I don't rightly know how to get to Tulsey.

**Rider:** Boy! You people sure are dumb. You don't know anything, do you?

**Pa:** Well..... it's this-a-way. We might not be right smart... but we ain't lost!  
(Curtain)

## LAMP POST

**Actors:** 3-6 persons  
**Prop:** 1 flashlight  
**Setting:** One person comes in with flashlight and announces: "I am a lamp post." He stands, holding light for the remainder of skit.

(2nd boy comes in and begins to look for something near light)

**3RD BOY:** (Enters) What are you looking for?

**2ND BOY:** I have lost a dollar and I just have to find it:

(3rd person begins to help look)

**4TH BOY:** (enters) What are you looking for?

**2ND BOY:** I have lost a dollar and I just have to find it.

(4th person begins to help look)

(Continue this procedure until last person enters)

**LAST BOY:** What are you looking for?

**2ND BOY:** I have lost a dollar and I just have to find it.

**LAST BOY:** Where did you lose it?

**2ND BOY:** Down the street.

**ALL** Then why are we looking here?

**2ND BOY:** Because this is where the light is!

MAY 4

## ODE TO A CUB SCOUT LEADER

(Tune: Battle Hymn)

He was only 7 years old when they called me to the force. I said, "I'm not equipped!" They said, "Oh yes you are. What's more we will train you in the basic. We'll outfit you for the corp." and they shove me out the door.

Chorus:

Glory, glory. I'm a leader. How'd I get to be a leader? All I did was have a S-O-N. Is this the price I pay?

They taught me to be thrifty, to be thoughtful, to be true. They taught me how to string beads like noble Indians do. I had to learn to dig a trench, and how to use it too. And you should taste the stew.

Chorus

I had to learn to sing songs that I didn't understand. I learned to dance the Polka, and to make a rhythm band. To think of what to do, and to forget what I had planned. And they say that Scouting's grand!

Chorus

We went walking in the woodland, my Cub Scout Den and me. The handbook says that nature has a wealth of sights to see. It's true---we sure see sights when we were found eventually. And I do this all for free!

Chorus

But even though I grumble and I mumble and I shout. Though there were days I wonder what's the best way to get out. I guess when all is said and done. There isn't any doubt. I'm glad to be a scout!

## QUARTERMASTER'S STORE

There are snakes, snakes, snakes  
Big as garden rakes  
In the store, in the store  
There are snakes, snakes, snakes,  
Big as garden rakes  
In the Quartermaster's store.

Chorus

My eyes are dim,  
I can not see.  
I have not brought my specks with me.

There are mice, mice, mice,  
Running through the rice,  
In the store, In the store  
There are mice, mice, mice  
Running through the rice  
In the Quartermaster's store

Chorus

There are rats, rats, rats  
Big as alley cats,  
In the store, In the store,  
There are rats, rats, rats,  
Big as alley cats,  
In the quartermaster's store

Chorus

## TAPS

Day is done,  
Gone the sun,  
From the lakes,  
From the hills,  
From the Sky;  
All is well, safely rest  
God is night.

**JUNE**

**TRAILS, TREKS, AND  
TRACKS**

**THE CUB SCOUT TRAIL**  
**(AN OPENING CEREMONY)**

**PROPS:** The only thing needed for the ceremony is a poster showing a mountain, on which there has been drawn a distinct trail. Have the boys in your den draw this poster as one of their projects. As each Cub says his part, he places the proper Cub Scout sticker (available at the scout office) in place along the trail.

As each Cub comes on-stage and says his part, he places the sticker or badge in a specific place along the Cub Scout Trail.

**CUB #1:** I am a BOBCAT - a beginner on the Cub Scout trail. Once, I pass my Bobcat requirements, I'll be on my way.

**CUB #2:** I am now a Wolf Cub along the Cub Scout trail. I've earned my badge and arrow points and am ready to go another step of the way.

**CUB #3:** A Bear Cub Scout I have become. I'm in my second year. Up, up the Cub Scout trail I go -- soon to be a Webelos.

**CUB #4:** Webelos is the name for me. I spend my time earning Activity badges; but there's still one more step for me. (Also places the Webelos colors higher on the trail.)

**CUB #5:** I, too, am a Webelos, but I have reached the top. I've earned the Arrow of Light Award (places the badge or sticker on the top of the mountain), but I have one more step. By earning my Arrow of Light, I've studied quite a bit about Scouts. Now I can't wait to become one. (He puts on a Boy Scout hat.)

JUNE 1

## **“PUZZLE” ADVANCEMENT CEREMONY**

**Equipment:** “Puzzle” Ceremonial Board shown; easel board

**Personnel:** Cubmaster, Webelos den leaders, advancing cub Scouts and their parents

Call forward all boys who are to receive awards, with their parents.

**Cubmaster:** In a way, our pack is like this jigsaw puzzle we have on the table. The pack has many pieces - boys and parents - who work together to make the pack go and grow. As we present our advancement awards tonight, we will see how we work together to make the big picture of our pack and of Cub Scouting.

(Cubmaster and Webelos den leaders give the advancing boys their piece of the puzzle; each piece has the boy’s awards taped to it. The parents remove the award and pin them on their son’s shirt. boys and parents then work together to complete the puzzle.)

**Cubmaster:** There, the puzzle is finished. each Cub Scout and parent contributed to make the big picture. That is the story of our pack - people working together.

### **CHEERS**

**FREIGHT TRAIN:** This applause simulates a freight train in the distance, approaching the station, and then fading off again. Use a four-beat hand clap with the first beat of each grouping of four loud and then the following three softer beats. The train can speed up, slow down, stop, start, with varying tempo. Throw in a few train whistles for sound effect.

**Locomotive:** Begin by slapping your left arm slowly with your right hand. Gradually increase speed, working down over the left palm peering into distance. Imitate train whistle - “Whoo - Whoo”



**CUB SCOUT AND PARENT PROMISE CEREMONY  
FOR GRADUATING TIGER CUBS**

(For inducting Tiger Cubs and their adult partners into the pack)

- EQUIPMENT:** Certificate of Graduation, Tiger Cub one-year pin.
- PERSONNEL:** Tiger Cubs group coach, narrator, Cubmaster, graduating Tiger Cubs and the partners. The Tiger Cubs group coach escorts the boys and adult partners to the ceremonial area.
- NARRATOR:** “Today these Tiger Cubs and their partners are taking their first big step on the Cub Scouting trail. Will the Tiger Cub coach please present the Tigers and their partners to the pack.” (Coach gives each boy’s and partner’s name.)
- NARRATOR:** “As Tiger Cubs, you searched, discovered, and share. Now, as Cub Scouts, you will face new challenges, learn new skills, and strive to become good citizens. Yours partners’ role will be changing, too, but its importance will not. We ask you partners to continue to support you boy by helping him and our pack, perhaps as a leader.”
- CUBMASTER:** “Welcome to our pack! Now we ask you to join me in giving the Cub Scout promise. (use repeat after me method: I promise/ To do my best/ To do my duty to God and my country/ To help other people/ And to obey the Law of the Pack.)  
“Now partners, we ask you to raise your right hand and repeat the Cub Scout parent’s promise. Please repeat after me: “I promise to work with my boy/ and to support him/ as he strives to advance in Cub Scouting./ I will work with him, and I will do my best/ to help the pack grow for all the boys./ I will accept responsibility within the pack/ to ensure a strong program.”
- Cubmaster gives the certificates and one - year- pin to partners to present to their boys. Have song leader lead “CUB SCOUT WELCOME SONG”

## GRADUATION CEREMONY FOR BOYS TO THEIR NEXT RANK.

**EQUIPMENT:** Tiger Cubs to Wolf- four candles, three in back one in front.  
Wolf to Bear - blue, white, and yellow candles  
Bear to Webelos - a door way  
all boys should have next rank neckerchief and slide ( put name on a piece of tape on back of old and new neckerchief)

### TIGER CUBS TO WOLF:

Will the following Tiger Cubs and their parents please come forward. (read names)  
For the past few months you and your family have explored all sorts of new and exciting things and places. You have taken each part of the Tiger Cub motto: Search, Discover, and Share and used it in your home, school and neighborhood. (light left candle) you and your adult partner have searched out in your home and community new activities which have shown you how people work together and have fun together.

(light middle candle) You and your adult partner have discovered that by doing things together with friends and family you feel a sense of being part of a great family, community and country. (light right candle) The things you have searched out and discovered have been shared with your family, friends and fellow Tiger Cubs, which let them learn about you and the things you saw and did. Now it is time to move along the Scouting trail to the next part of the program.

(light front candle) In Cub Scouting your family is still important as it is throughout your whole scouting experience. Support in earning each badge comes from your family as well as from your Den Leader. Your parents will help you each step of the way. (read boys and parents names) On behalf of Pack \_\_\_\_, I'd like to welcome you. Parents place the Cub Scout Wolf neckerchief around your son's neck. You are no longer a Tiger Cub you are a Wolf Cub of Pack \_\_\_\_.

### WOLF TO BEAR

(blue/white/yellow candles) This is the spirit of scouting. (light white candle) The blue candle represents truth/loyalty. The sky so blue, steadfastness and spirituality (light blue candle) The gold candle represents good cheer and happiness and sunlight so clear (light yellow candle) Will all Wolf Cubs that are moving up to Bear Cubs please join me to the right of the candles. Will all the parents of those Wolf Cubs come forward and stand to the left of the candles.

## WOLF TO BEAR CON'T

As each Wolf's name is called Cub and parents please step forward in front of the candles. Parents then take off you son's yellow neckerchief and replace it with the blue Bear neckerchief. ( call names Wolf Cub ---- after blue neckerchief call Bear Cub ---- and parents please step back.)

## BEAR TO WEBELOS

Will all the den leaders with Bear Cubs going on to Webelos please escort these Bears and join me this side of the door way to Webelos adventure. Tonight we have some Bear Cubs who have graduated the third grade and will be joining our Webelos Den to prepare them for the adventure of Boy Scouting. Will the Bear Cub parents and the Webelos Leaders please come forward and stand to the left of the door way to adventure. When a boy becomes a Cub Scout he starts on an upward trail. I say "upward" because as he grows older he advances in Cub Scouting.

He does not join a Cub Pack and then waits idly for four years until he becomes a Boy Scout. With the help of his parents and leaders he works and earns the various badges of achievement. Now you can see that these Cub Scouts are on the upward trail. Now that these Cubs are old enough they are moving forward and upward into another phase of Cub Scouting ---- They are becoming Webelos Scouts. My congratulations to you Cub Scouts and your parents for the fine work that you have done in Cub Scouting so far --- Keep up the good work as Webelos.

(Den Leader explain to boys - how they will remove their neckerchief and slid and send them though the door. Webelos Leader explain to parents how they will place their Webelos neckerchief and slid on their son) (Each Den Leader will escort their advancing Cub Scouts one at a time to the door to adventure. Remove their blue neckerchief. Salute them and let them go through the door as you call out their name. Their Webelos Leader will receive them presented them with their Webelos colors. Their parents will present them with their new neckerchiefs and slide.

JUNE 5

## DEN LEADER RECOGNITION CEREMONY

**MATERIALS:** Appreciation certificate ( additional token, optional) for each den leader and Webelos den leader.

**CUBMASTER:** There is something which parents sometimes overlook when they consider the possibility of serving as den and pack leaders. There are two very different types of homes. In one type, everything will always be just so. The furniture is not likely to be marred; there will be little shouting or noise except from the boy who lives in that house; and even shouting will be subdued and experimental. His mother will seldom be troubled by the shouts of other boys, because it is not likely that they will come there. And unless something unusual happens, that is the type of home it will always be. As the children who live in it become young men and women, the rug will never be rolled up for social occasions. They will take their noise and laughter where it is better understood and more welcome.

But there's is another type of home. This type attracts the friends of the children who live in it. They would rather bring their friends there than join them elsewhere. It is a home where children are welcome, where they learn to take care of the furniture rather than preserve it through lack of use. It's a home which later will attract young people.

It's true - the first type of house will be peaceful, because it will be empty. Too empty.... too peaceful .... too quiet.

But there are more wonderful things to be sought after in life than peace and quiet. And besides, if you live in the second type of home, it does not mean that all of your own personal comforts and pleasure must be sacrificed. Lasting satisfaction comes from the knowledge that, as each day goes by, you are guaranteeing your children's future memories of their home will be happy ones.

Most den leaders want the second type of home, and they have started to build now, because in a year or two it will be too late. That's why Cub Scouting is not all giving on their part. They'll receive a finer home life and stronger family because of it.

(Call forward all den leaders)

These people are making one of the finest possible contributions to our community by serving as den leaders. they not only deal with boys, but with parents, too. They are strengthening the life of our community by enriching the lives of the families who live in it. They are teaching boys to respect their homes and their parents and they are helping parents understand their boys better by doing things with them. Few community services are more important than this.

Please accept these certificates as a small token of our gratitude for your help in Cub Scouting, and the thanks of all the boys you are helping by your service.  
Thank You.

(Cubmaster gives a certificate to each leader and a Cub Scout handshake, too.)

## DEN CHIEF RECOGNITION CEREMONY

**PERSONNEL:** All den chiefs and Cubmaster.

**MATERIALS:** Appreciation certificate for each den chief

**CUBMASTER:** Cub Scouting is different than Boy Scouting. Like Boy Scouting, it has its games, crafts, advancements, and good will projects. The difference is in the type of activities that boys 7 - 11 years old like to do. The person who knows these activities best is one who has been a Cub Scout.

It is the job of the den chief to help lead den activities that will help these boys to be good Cub Scouts and Webelos Scouts, and eventually good Boy Scouts and Explorers. Den chiefs set a good example by being both a leader and a friend.

Tonight we would like to recognize those who serve our pack as den chiefs.

(Call names and den numbers all den chiefs)

We would like to ask that you re-pledge yourself to your responsibility as den chief. Please repeat the Den Chief's Pledge after me:

I promise to help the Cub Scout in my den.

To the best of my ability,

To encourage, guide, and protect them

In all den and pack activities,

and to show them by me example

What a Boy Scout is.

I will strive to be prompt and dependable,

And to cooperate with the leaders

In carrying out the den program.

As each Cub Scout reaches 9 years of age

Or completes the third grade,

I will encourage him to join a Webelos den.

As he reaches 11 years of age

I will do all in my power to

Interest him in becoming a Boy Scout.

(present each den chief with an appreciation certificate, followed by a Boy Scout handshake and a Thank You) Applause from the entire pack.

JUNE 7

## DEN LEADER FAREWELL & INDUCTION CEREMONY

### CUBMASTER:

I have a recipe I'd like to share with all of you. It makes Better Citizenship. First you take:

- 1 Cup of Affection
- 1 Cup of Courage
- 1 Cup of Loyalty

Mix these ingredients together and set to one side. Sift into a large bowl:

- 3 Cups of Unselfishness
- 2 Cups of Devotion
- 1 Cup of Ability

To this mixture, add:

- a pinch of fun - loving sport
- a dash of training
- a shake or two of Responsibility and Interest
- a handful of patience

Mix all ingredients together, beat well, and bake in a moderate person. Cool, and frost with Blue and Gold. Serve with seven Cub Scouts. The outcome is always terrific!

To night we must Bid "Good-bye" to a Den Leader who has all of these ingredients; and who has unselfishly served her Cubs and our Pack for # of years.

Will the boys of Den \_\_\_\_ please escort \_\_\_\_\_ forward.

\_\_\_\_\_, in behalf of Cub Scout Pack \_\_\_\_\_, it is my privilege and honor to present you with this small token of our appreciation for all of the hours that you have spent in giving something to our Cub Scouts, so that they may grow into better young men and good citizens of our country.

Now, will the boys please escort the new Den Leader of Den \_\_\_\_ forward.

\_\_\_\_\_, we welcome you as a Den Leader into our Pack. Yours is a big, but rewarding responsibility. Without Den Leaders, we could not have Cub Scouting. I believe I speak for the parents and the boys of your Den, as well as for the Pack, when I Say, "We'll do our Best" to help you make the Den go.

Give a cheer for these Den Leaders!

**JULY**

**OUR NATIONAL  
TREASURES**

## OLD GLORY SPEAKS

### OPENING CEREMONY

Colors are advanced in the normal manner. Voice speaks as if "OLD GLORY" speaking.

**VOICE:** A great host of heroes with the help of God kept me gallantly flying in the face of every threat and challenge to the democratic way of life which I represent.

The blood spilled at Valley Forge, Gettysburg, San Juan Hill, Bataan, Korea, Vietnam, Desert Storm, and every other great battle fought on land, in the air, and on the sea, is my red stripes.

The shining light of sunshine is in my stripes, penetrating the blackest night which, in the nation's darkest hours is filled with radiant light.

The vast infinity of the heavens is in my stars inspiring mankind to continue climbing courageously up the spiral staircase of history to world of glowing promise.

I am the emblem of man's finest dreams. I am the last hope for peace on earth. I am "OLD GLORY".

### CLOSING

#### AMERICAN DREAM

**CUBMASTER:** America is a melting pot of people from many lands. They came here to worship and live as free people. This inspired many to dare to dream. These dreams lead to a better life for all. Benjamin Franklin discovered electricity. Thomas Edison invented the telephone. Henry Ford dared to make a horseless carriage. Man learned to travel through air; television was born; and man even walked on the moon. Through good times and bad the American dream has lived. I challenge each of you to dream. Dream for an America full of tomorrow's and work to make those tomorrow's come true. Goodnight Cub Scouts.



## ADVANCE IN RANK CEREMONY

**PERSONNEL** - Cubmaster, Webelos den leader, advancing Cub Scouts and Webelos Scouts, their parents.

**EQUIPMENT** - "TROPHY SKIN" badges, arrow points, activity pins, and arrow points all badges and pin on trophy skin in ascending order .

**CUBMASTER:** "This month our cub Scouts have been working hard to advance in rank. Tonight we will honor those who have achieved a new rank or earned arrow point. We're very proud of them and their parents, too. Because you know a Cub Scout can't advance without help from his family. And although our Webelos Scout don't pass advancement requirements to their parents, they do need their parents encouragement. So we're going to ask them to take part in our ceremony, too.

*Cubmaster then calls forward boys who have earned Wolf rank, with their parents. Each boy takes his Wolf badge from the trophy skin and parents pins it on his uniform shirt. The Cubmaster explain briefly how the badge was earned by passing 12 achievement to parents. Follow the same procedure for Bear Badge and arrow points.*

*Webelos den leaders then use the same ceremony to award activity badges and Webelos badge.*

When all awards have been given. Cubmaster says: "Advancement is just a part of the fun of Cub Scouting., but it's an important part. Through advancement the boys learn new skills that will help throughout their lives.

JULY 2

## SONG

### I LOVE AMERICA

Tune: Battle Hymn of the Republic

I love this great America,  
The land that God has blessed,  
Where the hope that stirs the hearts of  
men will never be suppressed.  
Through the flame of faith came forth  
a nation choice above the rest,  
This great America!

#### CHORUS:

Glory to the land of freedom,  
Glory to the land of freedom,  
Glory to the land of freedom,  
I love America.

I love this great America,  
The land of liberty.  
For I know the price of freedom  
countless others paid for me.  
Do we hear their call to carry on  
and serve as valiantly?  
This great America?

#### CHORUS:

May all men be united by  
bonds of brotherhood.  
May we learn to love each other,  
for in every man is good.  
Let us live in peace upon the land  
where men of valor stood.  
This great America.

#### CHORUS;

I love God's great America,  
All equal in his sight.  
May we be as one in spirit as  
we reach up for the right.  
And may we have humility  
to match our power and might,  
This great America?

### THE CAMPING SONG

Tune: She'll be commin' round the  
Mountain

I'll be going on the camp-out when it  
comes, when it comes  
I'll be going on the camp-out when it  
comes, when it comes  
I'll be going on the camp-out  
I'll be going on the camp-out  
I'll be going on the camp-out when it  
comes, when it comes

I'll sing song around the camp fire when  
it comes, when it comes  
I'll do skits and tell ghost stories when it  
comes, when it comes,  
I'll have fun at our pack camp-out  
I'll have fun at our pack camp-out  
I'll have fun at our pack camp-out when  
it comes, when it comes

I'll go hiking on our camp-out when it  
comes, when it comes  
I will gather leaves and acorns when it  
comes, when it comes  
I'll be going on the camp-out  
I'll be going on the camp-out  
I'll be going on the camp-out when it  
comes, when it comes

### CUB SCOUT VESPERS

Tune; O Tannenbaum

Softly fall the light of day  
As out campfire fades away  
Silently each cub should ask  
Have I truly done my best?

Have I helped the Pack to go?  
Has the Pack helped me to grow?  
Have I stood above the crowd?  
Have I made Akela proud?

# TROPHY SKIN

Use the trophy skin to display extra badges you have earned and decorate your room.

## MATERIALS

Two 18" sticks or dowels

Two 15" sticks or dowels

Four 12" pieces and one 90" piece of hemp twine

Four 12" pieces of bell wire

One 12" x 15" piece of thin vinyl

## PROCEDURE

1. Bind the four sticks or dowels together with bell wire to form a rectangle. Be sure to make these joints as rigid and tight as possible.
2. Cut the piece of vinyl in the shape of a skin, following the pattern in the picture. Punch holes around the edges as indicated.
3. Tie the four corners in place with the four 12" pieces of twine. Then lace around the skin with the 90" piece of twine.
4. Your badges may be sewn, stapled, or glued to the skin.

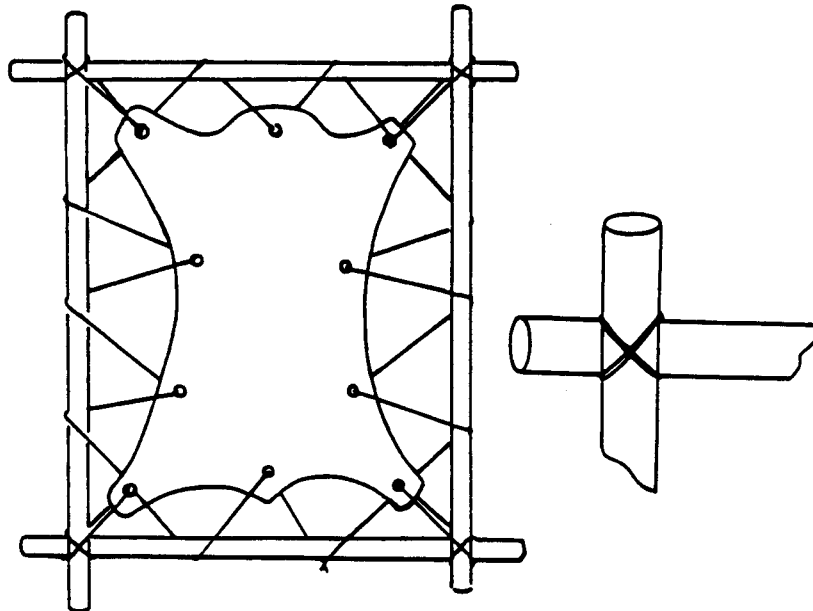

July 4

TEACHING AID FOR POCKET KNIFE SAFETY

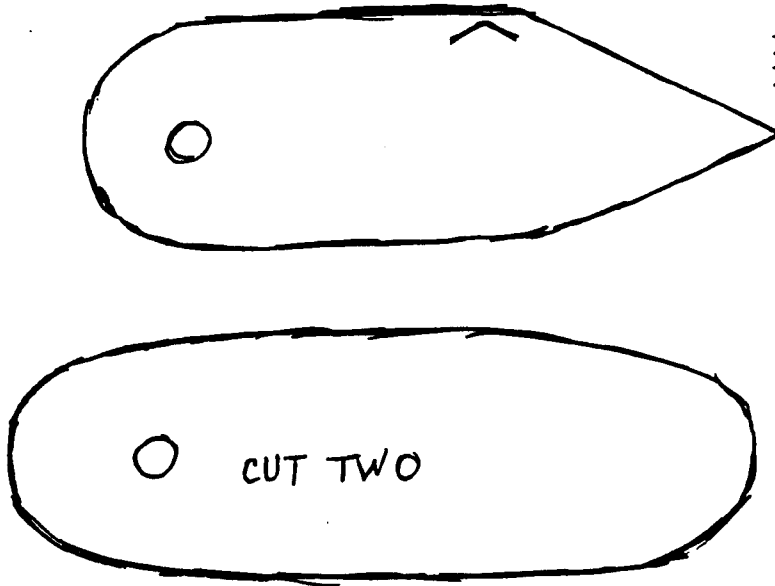

Cut "pocketknife" from poster board as shown, using white for blade and another color for the case. Fasten one end with a paper fastener. Be sure holes as shown on pattern to line up properly when blade is in or out. Blade needs to extend above handle edge, so be sure staples are placed as shown, to stop blade from slipping completely into handle.

**TO USE:**

Put lipstick on the edge of the blade before using. If lipstick appears anywhere but on the article being "whittled", the whittler has cut himself!

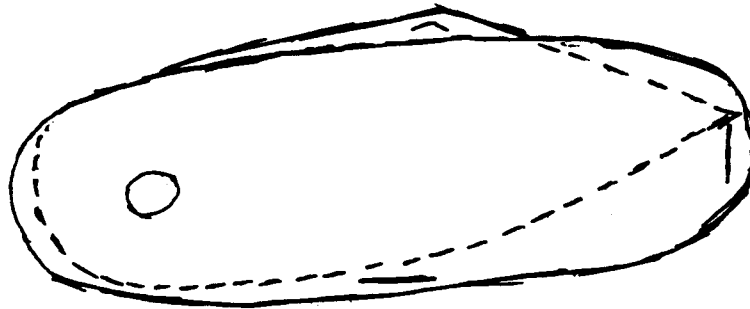

KNIFE SAFETY TIP  
Don't lay your knife down when finished. Always close it and put it into your pocket.

KNIFE CARE: A boy needs to know how to open and close it safely, how to sharpen it, how to keep it clean, and how to use it properly.

\*\*\*\*\*

BULB OR BATTERY TESTER

Materials: about 6" of 16-18 gauge wire, flashlight bulb, battery

Make a loop in one end of the wire to wrap around the bulb base. Curve the wire so the other end easily reaches the base of the battery when the bulb is touching the top. Warn boys that the tester should only be used with low voltage bulbs and batteries, never with electric sockets, lamps or appliances.

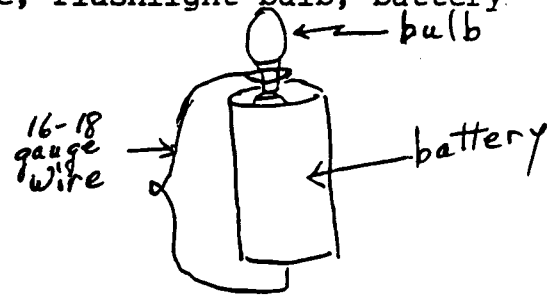

DEN OPENING: Have Denner conduct roll call with each Cub Scout responding with the name of a carpenter's tool (or plumber's, painter's etc. tools.)

July 6

**AUGUST**

**SPLISH, SPLASH!**

## AWARD CEREMONY

You will need two flashlights (one with blue cellophane over the end and the other with gold cellophane over the end, or plastic or tissue paper could be used. A third flashlight will also be needed with red paper over it.)

Cubmaster and two pack leaders will be needed.

**CUBMASTER:** Here we have the blue light of Cub Scouting on my right (leader stands beside Cubmaster and turns on blue flashlight) and the gold light of Cub Scouting on my left (leader turns on gold light). These two lights symbolize the light of Cub Scouting which can shine brightly in the lives of our boys but only with the help of parents to make them shine. There have been some Cub Scouts in our pack this month who have had those Cub Scouting lights shining in their lives and they've worked hard to pass off some achievements and electives. (Cubmaster need to say appropriate words for awards given.) Would the following Cubs and their parents come forward and stand in the Cub Scouting's Blue and Gold limelight together as we recognize them for the fine work they have done.

Call forth appropriate Cubs and parents and make presentation telling about awards Cubs Earned. After awards given turn off blue and gold lights and turn on red light.

**CUBMASTER:** We all know that red means stop so let's all stop for a minute every once in a while and ask ourselves if we are really doing the best we can whether as a Cub Scout, a parent, a leader or family member. Parents ask yourself if you've really helped your boy so that Cub Scouting can be a shining light to him. Let's all do our best to keep those Blue and Gold lights shining. (turns off red light and turn on blue and gold lights). Then we can all see our sons step up and receive some of the Blue and Gold limelight for his accomplishments.

Note -- the last part of the ceremony could be worked in as the closing ceremony for the pack meeting.

## GOING FISHING

**SETTING AND PROPS:** Collect a lot of fishing equipment - tackle box, fancy rod and reels, lots of plugs, spinners, waders, net, creel, etc.

**THE CHARACTERS:** Bill, Bill's Dad, and Several Other Men

**THE PLOT:** As the scene opens, the MEN are gathered around the fishing equipment, talking about a fishing trip they are planning. They pick up the different pieces of equipment and try them. Two of them argue about the merits of bait casting against fly fishing. The more elaborate, the better.

Finally, **BILL'S DAD** says, "I think I'll take my son **BILL**, along on this trip. He doesn't know what fishing is all about."

One of **MEN** answers: "Yes, it will be lots of fun for **BILL**, He'll have the time of his life! You've got all the equipment you need. That's what it takes to catch the big ones.... the right kind of tackle!"

**SURPRISE ENDING:** **BILL** enters, barefooted, wearing old jeans, a beat-up straw hat, and carrying a branch with a string on it and a safety pin on it. He is carrying a **BIG STRING OF BIG FISH** (cardboard ones). He says, "Did I hear someone mention my name?"

## TAKING THE PENGUINS FOR A RIDE

**Cast:** Penguin keeper, penguins, police officer

**Scene:** A highway

**Action:** A man with a busload of penguins chugs across the stage. A police officer stops the driver and asks: "Where are you taking these penguins?" The driver responds: "I'm taking them to the beach." The officer advises him to take the penguins to the zoo instead. The driver obliges, changes direction, and chugs off with the penguins. Shortly, the driver chugs back on stage with his busload of penguins. The police officer stops him again; "I thought I told you to take these penguins to the zoo!" The driver replies: "I did. They had a great time. Now I'm taking them to the movies!"

## GONE SWIMMING

DEN LEADER: Ok boys, this month we're going to talk about water safety. We need to learn how to be safe while swimming or boating.

DAVID: Are we going to get a chance to do any swimming?

PEST: But Mr. Jones.....

KEN: We need to be able to take care of ourselves in the water so can you show us how?

DEN LEADER: We will go in the pool in a few minutes.

PEST: But Mr. Jones.....

DEN LEADER: Danny: keep quiet!! We're learn enough to get our Aquanaut pin and you keep interrupting.

STEVEN: Will you show us how to dive safely?

DEN LEADER: Yes, as soon as we have water safety we will go to the pool.

PEST: But Mr. Jones.....

DEN LEADER: Danny, keep quiet!!

KEN: What do you want to tell us about water safety?

DEN LEADER: You must be careful not to go out too far where you can't touch bottom or swim back to safety, and you must never dive into water if you don't know what's under it. Now I'll show you how to dive into the pool.

PEST: But Mr. Jones.....  
CRASH!!!!!!

PEST: There's no water in the pool!

AUG 3



## SHIPPED WRECKED CUB SCOUTS

(Tune: Gilligan's Island)

Our Pack set sail on the sea one day,  
In search of coins of gold,  
A group of hearty Cub Scouts,  
And leaders true and bold,  
And leaders true and bold.

The weather started getting rough,  
The tiny ship was tossed,  
If not for the courage of the Cubmaster,  
The whole Pack would have been lost,  
The whole Pack would have been lost.

Our boat touched ground on a rocky isle,  
And up walked a tall, old man,  
He tossed a towel to dry us off,  
And raised his right hand,  
And raised his right hand.

He said "You're a sharp Pack of Cub  
Scouts."

"Your courage brave and sure,"  
"To set sail out on a sea like this"  
"On a Scouting adventure,"  
"On a Scouting adventure."

He gave directions to get home,  
We set sail with good cheer,  
We reached home with the setting sun,  
And tied up to the pier,  
And tied up to the pier.

We looked in the bottom of the boat,  
And saw the old man's towel,  
His name was stitched along the hem,  
The name was Baden Powell.

## CAMPIN' IN THE RAIN

(Tune: Singing in the Rain)

I'm campin' in the rain, just campin' in the  
rain,  
The tent and the campfire are soggy again,  
The clouds in the sky are making me cry,  
My waterlogged shoes will never dry.

All the mud in the place, is stuck to my face,  
The frogs and the turtles are starting to race,  
Oh what should I do, I need a canoe,  
A webbed footed weasel just ran off with my  
shoe.

I'm campin' in the rain, just campin' in the  
rain,  
The good doctor said I have water on the  
brain,  
I can't light the fire, I'm stuck in the mire,  
The lightening just knocked me down the  
telephone wire.

I'm drownin' in the rain, just drownin' in the  
rain,  
Won't it please stop rainin', I hate to  
complain.  
My sleeping bag's wet, I'm starting to fret,  
My lifejacket wasn't the thing to forget.

I'm campin' in the rain, just campin' in the  
rain,  
What a glorious feelin', someone just  
plugged the drain.  
The pre-cip-i-tate will not dis-si-pate,  
The sun will soon dry up the puddle I hate,  
No more campin' in the rain.

### LITTLEST WORM

(Tune: The prettiest girl I ever saw)

The littlest worm,..... I ever saw,.....  
Was stuck inside,..... my soda straw,.....  
(repeat together)

He said to me,... Don't take a sip,...  
For if you do,... I'll surely flip,...

I took a sip,... And he went down,...  
He went right down,... He must have  
drowned,...

He was my pal, ... He was my friend, ...  
And now his gone, ... And that's the  
end,...

And then I burped,... And he came up,...  
He came right up, ... Into my cup, ....

He said to me, ... That wasn't nice, ...  
You did it once, ... Don't do it twice, ...

The moral of, .... This little tale, ...  
If you see a worm, ... Just don't inhale,  
...

The littlest worm, ... I ever saw, ...  
Was stuck inside, .... My soda straw,.....

### MY DREAM CAME TRUE

(Tune: I've been working on the  
Railroad)

I was dreaming of a campfire, burning  
clear and bright.  
Sparkling stars were all above me, upon  
a summer's night.  
I was dreaming that my best friends all  
were dreaming too.  
When I woke and looked around me, I  
saw my dream came true.

### BACKYARD TREASURES

(Tune: Clementine)

In the backyard, there are treasures,  
There are treasures all around ,  
If you look hard in my backyard,  
All the treasures can be found.

Found some pine cones and an ant hill,  
And a toad, eating some bread.  
I can hide them in my pocket,  
And I'll keep them 'neath my bed.

Momma found them in my pocket,  
So she yelled and screamed and cried.  
"You can keep those rotten pine cones,  
But the frog, can stay outside."

So I took them to the backyard,  
To her flower bed to rest.  
I'm so glad she didn't find that  
Beetle hidden in her desk.

### CUB SCOUT VESPERS

Tune: O Tannenbaum

Softly falls the light of day  
As our campfire fades away,  
Silently each cub should ask,  
Have I done my daily task?  
For my country done my best  
Prayed to God before I rest  
Helped a friend along the way,  
Have I done y best today?

## NOAH

The Lord said to Noah, there's going to be a floody, floody,  
The Lord said to Noah, there's going to be a floody, floody,  
Get those animals out of the muddy, muddy,  
Children of the Lord.

### CHORUS

Rise and shine and give God your glory, glory,  
Rise and shine and give God your glory, glory,  
Rise and shine and give God your glory, glory.  
Children of the Lord.

Oh Noah, Oh Noah, he built him an arky, arky,  
Oh Noah, Oh Noah, he built him an arky, arky,  
Made it out of hickory, barky, barky,  
Children of the Lord.

### Chorus

The animals they came, they came by twosies, twosies,  
The animals they came, they came by twosies, twosies,  
Elephants, giraffes, and kangaroosies, roosies,  
Children of the Lord

### Chorus

It rained and it rained for forty daysies, daysies.  
It rained and it rained for forty daysies, daysies,  
Dam near drove those animals crazy, crazy,  
Children of the Lord

### Chorus

The sun came out and dried up the landy, landy,  
The sun came out and dried up the landy, landy,  
Everything is fine and dandy, dandy,  
Children of the Lord

### Chorus

This is the end, the end of my story, story,  
This is the end, the end of my story, story,  
Everything is hunky, dory, dory,  
Children of the Lord

### Chorus

## GAMES

MARBLE GOLF: Practice this game during den meetings for a marbles tournament. For holes, bury baby food jars to the rim. Flags are paper triangles glued to popsicle sticks. Add water hazards and sand traps as you wish. The "golf shots" are made in the approved knuckles-down way for regular marbles. Winner is the boy who takes the fewest shots to go around the course.

SCOOPER: Cut half - gallon plastic bleach bottles to make scoops. Use them for playing catch with a whiffle ball or rubber ball. Play hockey or keep away, with them.

CASTING RELAY: Divide parents and sons into two teams. Draw a five - foot circle on the ground as a target. In relay fashion, members of each team take turns casting with a rod and reel to hit the target. Mouse traps in the circle would make it more challenging. (A weight is tied to the end of the line.) First team to finish wins.

## ROCK, TREE, AND BRIDGE RACE

Equipment needed : None

Divide group into teams ( teams of six work best). Teams line up. The first person on each team runs out and kneels down to become a rock. The second person jumps over the rock and then raises their arms to become a tree. The third person jumps over the rock, runs around the tree, and bends over to become a bridge. The fourth person jumps over the rock, runs around the tree, goes under the bridge, and becomes a second rock. The pattern continues until the last player has run the course and becomes part of it. Then the first player leaves his position as rock and runs the course to the finish. The second person, who was a tree, follows as soon as the first player is home at the finish, and, one at a time, all players complete the now shortening course until all are home. The first team to have all players home is the winner.

# SCOOP GAME

Play catch with a friend or a family member

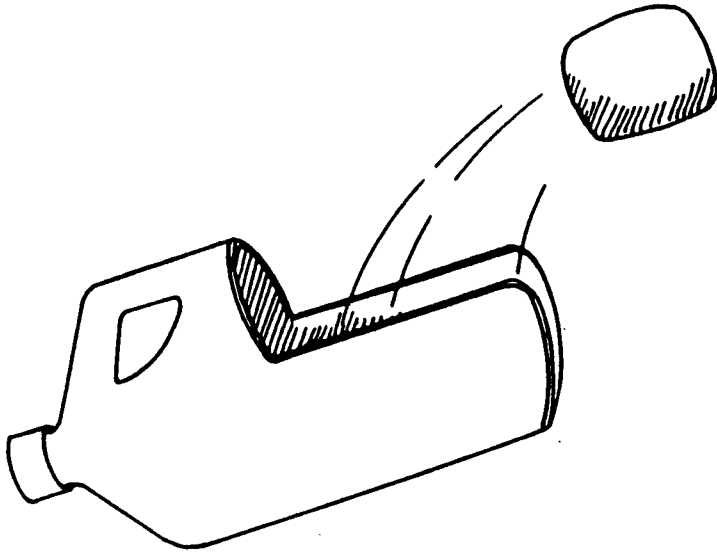

## MATERIALS

Plastic milk or bleach bottle

Scissors

4" x 8" piece of fabric (old jeans work well)

Rice or beans (dried)

## PROCEDURE

1. Wash bottle thoroughly.
2. Cut bottom and part of one side from bottle as indicated in the drawing. Your "scooper" is complete. Make a second one for your friend.
3. Fold fabric in half, right sides in, forming a 4" x 4" square. Sew almost around the square. Turn right side out. Fill with dried beans or rice.
4. Sew the opening closed.
5. Place beanbag in "scooper" and toss it underhanded to your friend. Practice catching and throwing the beanbag from the "scooper." You can also use a rubber ball, sponge ball, or foil ball to play catch.

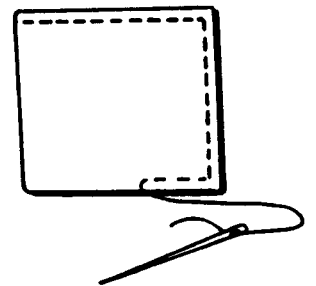
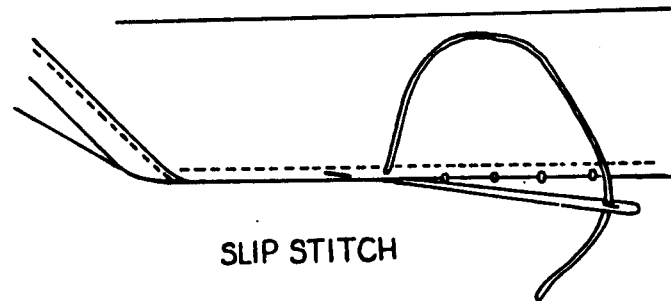

Aug 8

# WATERSCOPE

You can explore the wonders of the under-water world, watch the movement of fish, or study aquatic rocks and plants.

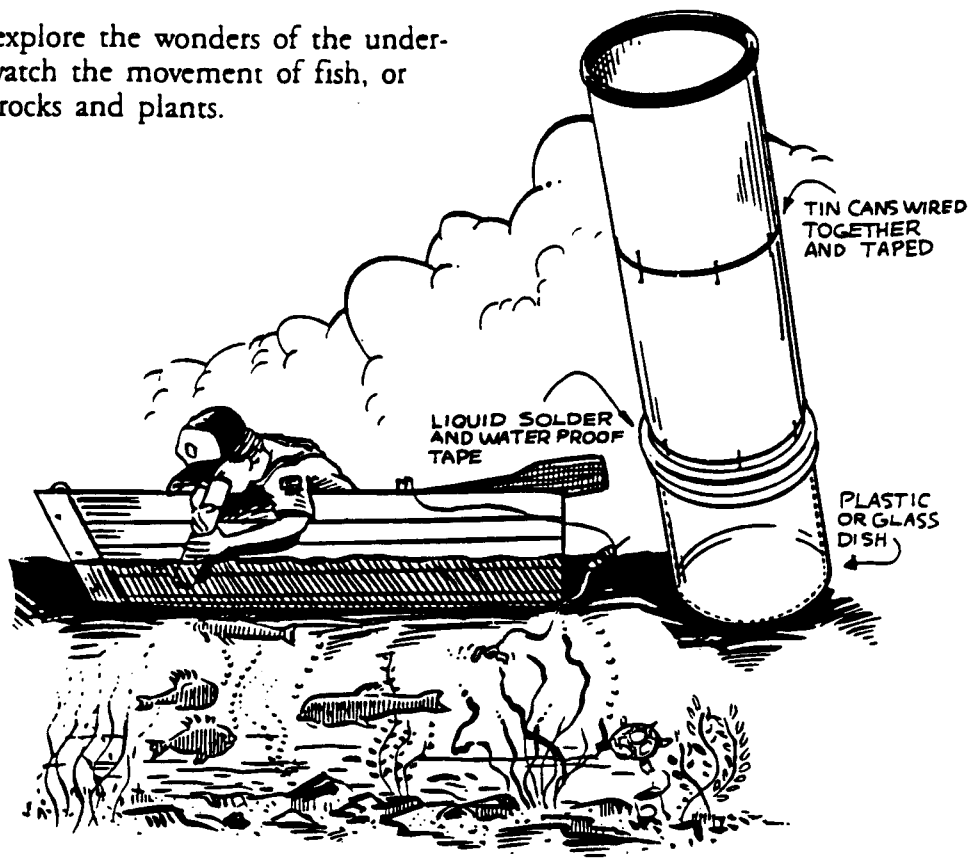

## ADVANCEMENT POSSIBILITY

Webelos Naturalist Activity Badge

## MATERIALS

Three large fruit-juice cans all same-size

1" wide waterproof adhesive tape

Glass jar slightly wider than juice cans

Wire

## PROCEDURE

1. Remove both ends from all three cans.

2. Place the cans end-to-end and align the seams. Fasten with wire and 1" wide waterproof adhesive tape.
3. Insert this cylinder into a jar and make the joint watertight with waterproof adhesive tape.

By eliminating surface reflections, the waterscope allows you to see directly under water. Be sure you have good footing on the dock, rock ledge, or rowboat before leaning over the water.

**NOTE:** Carefully check the edge of the can that will be against your face for jagged edges. Use a metal file to make rough edges smooth. For an added precaution, apply duct tape to cover this same edge.

Aug 9

**SEPTEMBER**

**HEY, LOOK US OVER**

## OPENING CEREMONY

Arrangement: Lights out. Candleholder with six candles, three blue and three yellow, is on a table. The Six Parents each light a candle and give there part of the ceremony.

PARENT 1: Some people think Cub Scouting is only for boys' but it isn't, Cub Scouting is for the family.

PARENT 2: Mothers and dads, as they work in Cub Scouting with their boys, are able to maintain their natural relationship with them, yet they come to see their boys' play and leisure in a new light. The Cub Scout advancement program ensures a closer boy - parent relationship.

PARENT 3: Cub Scouts are considerate of others. They promise "to help other people" and to do their best. When parents sign their boy's membership application, which is also a family contract, they take as their moot, "We shall help our son do his best."

PARENT 4: Cub Scouting is the basic part of the three - phased Scout program that reaches, through Scouting, to the Exploring program for boys and girls of high school age. Each part is packed with challenges most appropriate to the age involved and leads to the next phrase. Thus, when out Cub Scouts join the Webelos den and earn the Arrow of Light award they are prepared to enter Scouting with their joining requirements.

PARENT 5: Cub Scouting in all its phases operates to strengthen the home - not to weaken it. You and your family will strengthen your home only by living, playing and growing in it together.

PARENT 6: Today your boy is 8. He has only a few more years of boyhood left before he moves away from home for his principle interests. What you do together today is important. Tomorrow may be too late.

CUBMASTER: Will all parents pledge their support to Cub Scouting? Now join with the Cub Scout in the Cub Scout sign and repeat the Cub Scout Promise with me. "I, (name) promise to do my best....."



## THE STORY OF CUB SCOUT COLORS. AWARDS CEREMONY

Although we do not talk much about early Cub Scout lore and Indian lore, here at Pack \_\_\_\_, there is a story you may like. It also deals with the Cub Scout colors.

Many, many moons ago, the great Chief Akela called a Council Meeting to see what could be done to make the Webelos tribe the best of all the tribes. After much thought, he sent two of the tribe's best warriors on missions. He told the first brave to climb a mountain and tell the great eagle there to fly high into the sky and bring back part of the beauty of the sun. He told the second brave to go into the forest and tell a sparrow there to fly high into the sky and bring back part of the beauty of the sky. When each returned they carried bottles, much like the ones which I have here.

As Akela, I first pour some of the beauty of the sun into our council mixing pot. Then, I pour some of the beauty of the sky into the same pot. You can see from the smoke what effect each has on the other. And, when we mix well, look what can happen. (pull out the CS Neckerchief).

From this day forward, blue will stand for truth and loyalty and yellow will stand for warm sunlight, happiness and good cheer.

This is why the Cub Scouts use the colors of Blue and Gold. Now let us meet the Cubs and their parents who helped keep the spirit of the blue and gold strong this month. We have a number of awards to give out which I find in our mixing pot (call boys and parents up and hand out awards)

### NOTE:

The Blue and Gold colored water is produce with vegetable dye. Use dry ice.

### CLOSING THOUGHT:

May the road rise with you.  
May the wind be ever at your back.  
And may the good Lord hold you,  
Always in the palm of His hand.

## CUBMASTER INDUCTION CEREMONY

- PERSONNEL:** Old Chief Akela, new Cubmaster, Committee Chairperson, any other Committee Members.
- MATERIALS:** Indian headdress for Old Chief Akela, artificial campfire, Indian blanket.
- SETTING:** Former Cubmaster as Old Chief Akela is out of sight. Other personnel, stand beside the campfire.
- CHAIRPERSON:** We are expecting a visit from Old Chief Akela of the tribe of the Webelos. ( A knock is heard and Old Chief Akela enters)
- OLD AKELA:** I am here to help you install a new chief. Are the elders of the tribe assembled?
- CHAIRPERSON:** They are here, Akela.
- OLD AKELA:** Have they selected a new chief?
- CHAIRPERSON:** They have, and he is here. (The new Cubmaster is brought before the old Chief)
- OLD AKELA:** You have been chosen to be the new chief of the tribe of the Webelos. Will you be loyal to the trust that has been placed in you by our committee, Cub Scouts, and parents?
- NEW CM:** I will be loyal. (old chief puts his blanket on the shoulders of the new Cubmaster and a warbonnet on his head)
- OLD AKELA:** I declare you to be Chief Akela, of the tribe of the Webelos of Packs in the Southern New Jersey Council of the Boy Scouts of America. Do the young braves know the Law of the Pack.
- NEW CM:** They do.
- OLD AKELA:** Then let them stand and give the Law of the Pack.
- ALL CUB SCOUTS:** (Repeat the Law of the Pack in unison)
- The Cub Scout follows Akela.  
The Cub Scout helps the pack go.  
The Pack helps the Cub Scout grow.  
The Cub Scout gives goodwill.

## TIGER CUB INDUCTION CEREMONY

**Equipment:** 1 candle, and a picture of Tiger Cub. (lights out)

**Personnel:** Cubmaster and Tiger Cub Coach.

Cubmaster calls all Tiger Cubs and Partners to the front to stand in front of the picture.

**Cubmaster:** You have joined this program called Scouting. You are about to embark on a journey. A journey that is full of fun and one in which you and your adult partner will both search out new ideas, discover more about each other, and share this knowledge with your family.

However, as you start on the journey you will need a guide, a coach, to help you along the path. This guide is your Tiger Cub Coach, I now ask of the Guide, will you guide these new Tiger Cubs and their adult partners on the trail that leads to Cub Scouting? (yes)

I now ask you new Tiger Cubs will you follow the guide? (yes)

Adult partners will you also follow the guide and work with your Tiger Cub to see that he has fun along the trail to Cub Scouting? (yes)

Now will all Tiger Cubs and their adult partners repeat after me the Tiger Cub Promise giving the Cub Scout sign.

“I promise to love God, my family and my country, and to learn about the world.”

On behalf of Cub Scout Pack \_\_\_ I welcome you to the Tiger Cub program. Hand out cards saying. “This is your registration card as evidence of his membership in the Boy Scouts of America program.

# NECKERCHIEF SLIDES

# NECKERCHIEF SLIDES

## KINDS OF NECKERCHIEF SLIDES

### 1. Leather and vinyl

- a. Shape: many shapes may be cut from leather and vinyl ( Bobcat, Wolf, and Bear faces, arrowhead, basketball, baseball gloves, elephant, owl. Are just a few).

### 2. Wood

a. Shape:

1. Circles and ovals may be cut from slices of tree branches.
2. Any shape may be cut from thin wood (up to 3/8" plywood or pine).

b. Construction:

1. Cut out desired shape using coping saw or electric jig saw.
2. Staple strip of leather to back side.
3. Paint with enamel paint or use permanent markers.
4. Adhere stamps and other paper with Mod Podge or use mixture of half water and half white glue; a paint mixture or Mod Podge over stamp to seal and protect against water.

### 3. Plaster of Paris and resin

- a. Shape: You will need a mold. Molds may be found at craft stores, candy and cake decorating suppliers; also use cookie cutters, small containers, bottle caps, and Kool Aid scoops.

b. Construction:

1. Follow directions on the product you use.
2. A pop can ring may serve as a loop. Insert ring into plaster or resin before it hardens.
3. **NOTE: Do not pour leftover plaster and resin down drains!!**

- c. Painting Plaster: Many kinds of paint will soak into it is porous. It helps to seal the plaster with a spray sealer, spray plastic, gesso, or plain latex wall paint. After sealer is dry, any type of paint can be applied - tempera, water base paints will usually leave a dull finish. The latter can be given a coat of clear shellac or spray varnish for a shine. Avoid mixing lacquer and enamels - the paint will peel.

### 4. Recipes

- a. Salt-flour dough- ½ cup salt, 1 cup flour, water; Mix salt and flour together add just

enough water to make a stiff dough; Mix by hand/ knead. Color with tempera paint or food coloring.

- b. Flour Clay- 1 cup flour, ½ cup salt, 3 tsp. Alum, water: Add water a little at a time until mixture holds its shape. Food coloring can also be added.

## 5. Latex Molds

### Materials:

Liquid latex mold compound (brand names include: Mold Builder, Mold-It)  
Small inexpensive paint brush  
Object you want to duplicate  
Cheese cloth  
Base (plastic or foil covered cardboard or wood)

**"Original":** The item you want to duplicate! This can be made of wood, plaster, sculpey (bake-in-the-oven clay), plastic, ETC. The mold will have all the details of the original. Look for items that will be thick enough to be sturdy and that have either a "back" or "bottom" that will be open side of the mold (to fill with plaster).

**Base:** This needs to be larger than your original. The larger the original, the more surrounding area you should have. (A neckerchief slide needs about one inch around it) The easiest "base" is the lid of a coffee can or margarine container. They are moisture proof, reusable, or disposable. You can also cover cardboard or a piece of wood with aluminum foil.

**Mounting object:** The original must lay as flat as possible on the base and must not move while the mold dries. You can use a bit of rubber cement, glue or (my favorite) double-sided tape to hold the original in place in the center of the base. If an object does not have a flat back you can embed it in plasticine clay and flatten the clay around the slide to create a flat area around the object. If you are making a mold of a plaster slide with a loop back, you can cut a slit in the base to stick the loop through, then put something through the loop to keep it from shifting.

**Mold:** Follow the directions on the mold compound. You will be brushing multiple coats of latex over the original and extending beyond it in all directions. (This will form a "flange" the will support the mold when casting.) The first coat determines how the mold will turn out. It must be free of bubbles, so carefully brush the latex into all the nooks and crannies. After the first coat is dry, you can add a layer of cheese cloth on top of your next coat then cover it with more latex. This will build up the mold faster. Let this dry. Put it in the sun or under a low-wattage light bulb to help it along. Coat the top as necessary to seal the cheese cloth and to fill holes.

**To prepare for use:** When the mold is completely dry, peel the mold off the base/original.

You probably will have had some "leakage" around the original. You can turn the mold partially inside-out to trim the thin layer of "extra" (otherwise it can get caught in the plaster and possibly pull your duplicate apart). Use a sharp pair of scissors. It is easier to do if you gently stretch the part to be removed. Trim the extra mold and cheesecloth leaving 3/4" of so around the slide. If you are using a larger object, leave a larger flange.

To mold: Invert mold in glass, mug, bowl, ETC. So that the mold bottom is level. Fill with plaster; allow to set the peel mold off. If you lose the details of the design, it was not dry enough. The plaster needs to stay in the mold longer than in a plastic candy mold. If you have a very complex design and have trouble with air bubbles in the corners, fill the mold with water, and look for bubbles in the mold. Poke them with a toothpick to remove them, then gently pour out the water. When you pour in your plaster, remaining water will be displaced by the plaster and your mold should be bubble free. Doing this makes your plaster "soupier" than unusual so you can mix it a little thicker and definitely let it set longer before unmolding.

# CAMPING/ OUTDOORS/ KNOTS

## Axe and Log

### Materials:

Stick (1"- 2")  
Dowel  
Cardboard  
Glue



1. Cut a slit in the log (stick).
2. Cut an axe head.
3. Cut a notch in the end of the dowel.
4. Paint the stick and the cardboard axe head.
5. Glue together.
6. Add ring.

## Binocular Slide

### Materials:

1/2" dowel - 2 pieces 1" long  
1/4" dowel - 2 pieces 3/8" long  
1/8" dowel - 1 piece 5/8" long  
Paint (black, white, or blue)  
Wood glue  
Pipe cleaner  
Drill with 1/4" and 1/8" bits  
Coping saw  
Sandpaper

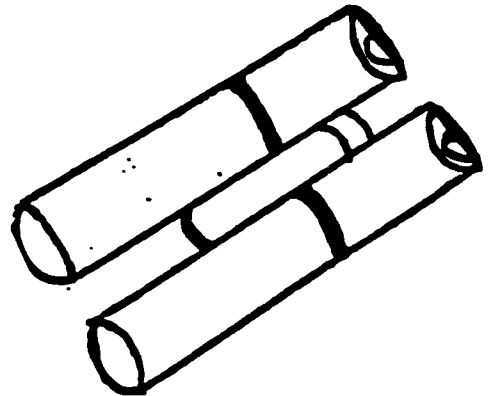

1. Cut dowels to length specified.
2. Drill 1/4" hole in one end of each 1/2" dowel, slightly off center and about 1/8" deep.
3. Drill 1/8" hole (for pipe cleaner) on underside at the same end as 1/4" hole.
4. Glue 1/4" dowel in the end holes of the 1/2" dowel.
5. Lay the two 1/2" dowels side by side about 1/16" apart with the two end holes to the center.
6. Glue 1/8" dowel in place, one end even with the top of the 1/2" dowel.
7. Sand and paint black with the lens end white or blue.
8. Glue pipe cleaner ends in the two small holes to form slide.



# PIONEERS

## Johnny Appleseed Slide

Attach pipe cleaner loop to an empty "Jet Dry" dishwasher rinse container or a small plastic cup. Glue red pom-poms inside and label "Apples".



## Big Foot Slide

### Version #1

Cut 2 feet out of cardboard. Glue together. Cut 3 inch strip of vinyl. Staple to form ring. Glue or staple to back of foot. Cover with paint or felt.

### Version #2

Carve one foot out of wood.



## Paul Bunyan Slide

Cut ax shape out of Balsa wood or cardboard. Paint "blade" silver and "handle" black or brown. Cement leather strap to back.

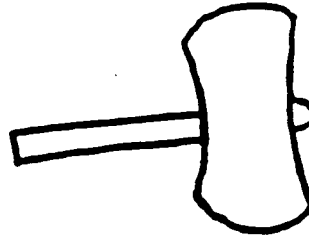

## Coonskin Hat

Form hat from fake fur, carpet pieces (sample pieces) or glue cotton batting onto a material section and then paint. Stitch the ends together to form the ring. Add a tail of the same material stitched together.

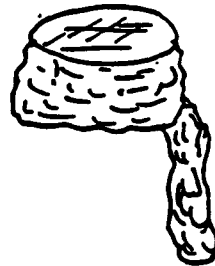

### Chuck Wagon Slide

#### Materials:

- 2- 3/4" nails
- 1- 1 1/4" nail
- 2- wheels

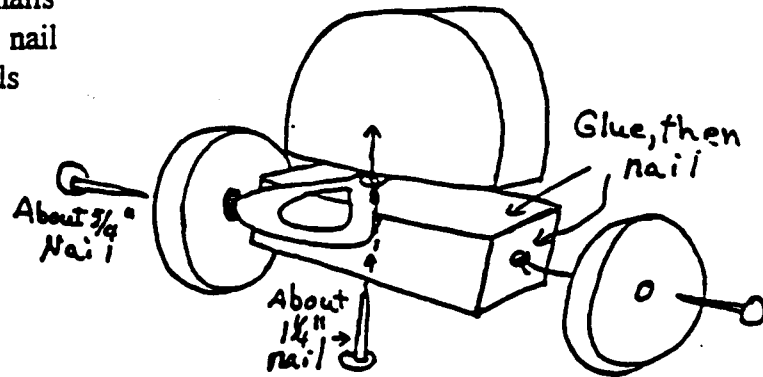

### Cowboy Boot

1. Cut a boot from craft foam or leather.
2. Decorate with a permanent marker.
3. Add spurs with a star-shaped bead and floral wire.
4. Add a ring.



### Cowboy Hat

1. Cut a hat from craft foam.
2. Draw shape with a permanent marker.
3. A hatband may be added with fabric paint.
4. Add a ring.



### Clothespin Cowboy

Remove lower half of clothespin "legs" and glue on fringe for chaps and a leather like belt. Paint features on knob. Add hat made of a leatherlike circle and daub of clay. Twist two pipe cleaners around neck: one for arms and the other for a loop.



# FIRST AID

## Band Aid Slide

### Materials:

- Thin piece of wood or tongue depressor
- Pipe Cleaner
- Band- Aid
- Clear contact paper

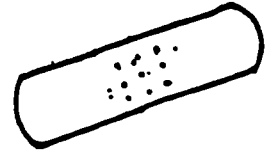

1. Cut a thin piece of wood or tongue depressor the shape of a band-aid.
2. Make 2 holes in the middle and make a pipe cleaner ring.
3. Then stick on a real band-aid and cover with clear contact paper

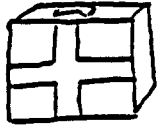

## First Aid Kit Slide

Use a small block of wood about 1/2" thick. Paint to resemble the example shown here. Attach PVC pipe or pipe cleaner to back.

## Neckerchief Slide First Aid Kit

### Version #1

For each slide, use a plastic or tin film can with lid. Punch two holes in back of can so slide ring can be inserted.

Paint can white. Paint on a red cross, or use small pieces of red plastic tape to make cross.

Glue in leather thong for ring, or use a plastic cafe curtain ring.

Put a small tube of antiseptic ointment.

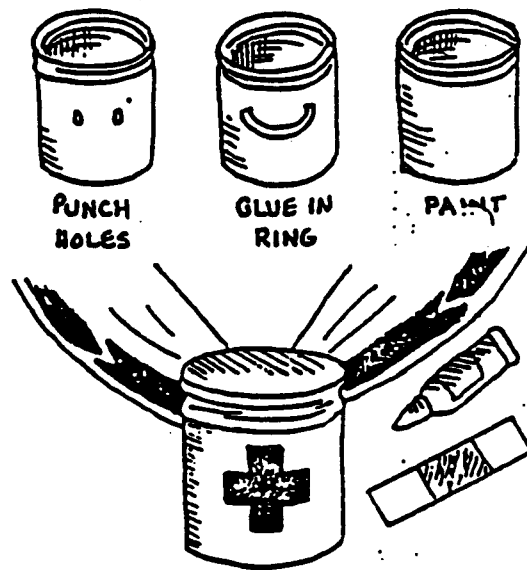

### **Version #2**

Punch two holes in back of film can. Make a red cross out of red cloth tape, and place on front of film can. Take a piece of plastic lacing or elastic string and thread through the two holes and tie a knot. Fill with things for a first aid kit.

### **Version #3**

#### **Materials:**

35 mm film can  
Pipe cleaner/ PVC pipe/ wire for loop  
Mirror  
Awl/ nail/ ice pick to make holes  
Hot glue  
Quarter  
Cloth tape  
First aid items

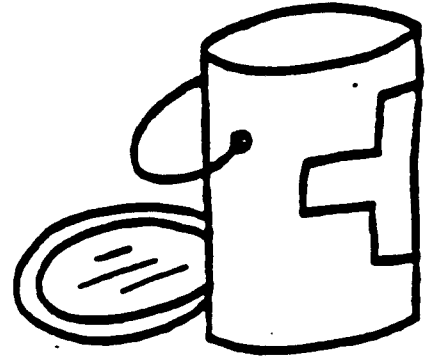

1. Glue mirror to inside of lid (for signaling).
2. A quarter is taped to mirror for emergency call.
3. 1 band-aid, antiseptic wipe, medicated ointment packet, 2 safety pins, piece of hard candy (wrapped), threaded needle wrapped around a card on which is written: name, address, phone number, parents names.
4. Wrap everything around the hard candy, pins and carded needle and stuff into canister.
5. Cover with quarter and lid

## Watermelon

### Materials:

Thin wood  
Paint- red, white, green, black  
PVC pipe  
Coping saw

1. Cut wood to pattern.
2. Cut out notch with coping saw.
3. Sand.
4. Paint.
5. Add PVC pipe to back for loop.

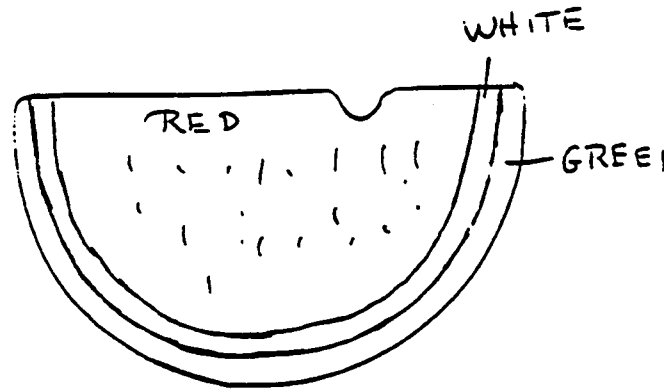

BLACK SEEDS

## Santa Tie Slide

### Version #1

Cut a paper towel tube into several 2" lengths. For the face, glue white or flesh-colored construction paper around tube. With markers, color the eyes and nose. For the hat, trace and cut out pattern from red paper. Glue hat to top of tube; glue cotton ball to hat peak. For the hair, glue cotton balls across the top of head below the hat. For the mustache, stretch a cotton ball and glue under the nose (can be used as a napkin holder also).

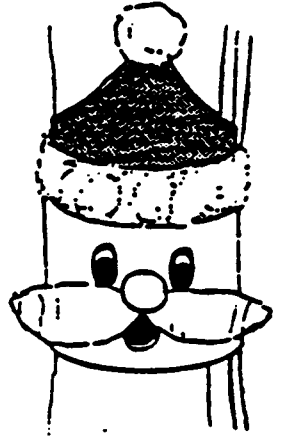

### Version #2

#### Materials:

Walnut shell half  
Red and white fun foam  
Cotton  
2 wiggle eyes  
Pom-pom

1. Cut backing, moustache, and hat band from white foam
2. Cut hat, mouth, and nose from red.
3. Glue walnut shell to backing.
4. Glue hat in place.
5. Add fluffy cotton beard, mouth, moustache, and nose in place.
6. Glue eyes and hat band in place.
7. Add pom-pom to hat.
8. Fasten a strip of foam to back for ring.

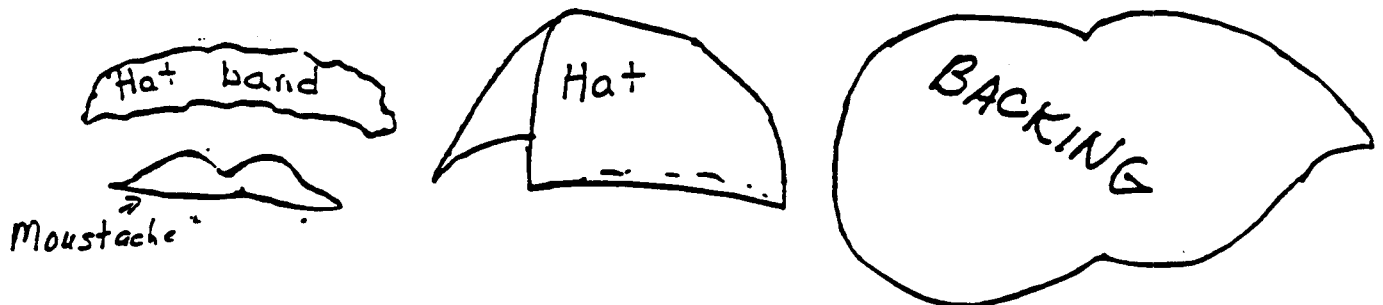

### Quiver and Arrows Slide

The quiver can be made from a small cylinder of vinyl, cardboard, leather, or a piece of an old plastic toothbrush holder could be used. Paint and decorate as desired. If you wish, the quiver could be covered with felt. Add a shoulder strap, using a piece of cord or narrow felt strip.

Arrows are kitchen matches (heads removed). Tiny bits of real feather fluff could be glued to the ends, or make fringed feather ends from construction paper. Glue inside quiver.

Punch two holes in back side of the quiver. Glue in pipe cleaner for slide ring.

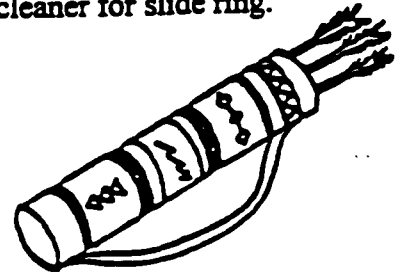

### Shield Tie Slide

Materials:

1-2" - 3" Circle from lightweight wood, cardboard, plastic bottle scrap

Paint

Glue

Decorations (feathers)

1- .5" x .5" PVC pipe

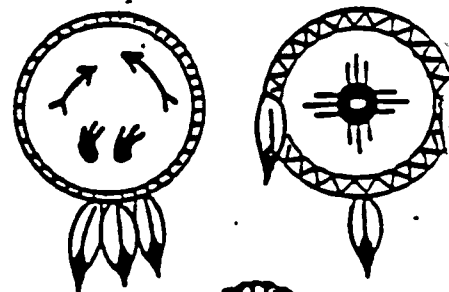

### Teepee Neckerchief Slide

Version #1

Whittle from 1/4" soft wood. Drill small holes for cord loop. Paint as desired.

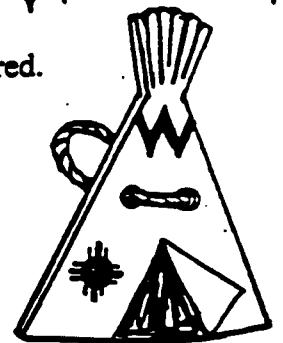

Version #2

Materials:

Round toothpicks

Markers

Pipe cleaner for loop

Heavy tan vinyl or brown shipping paper



Cut a half circle of vinyl or paper. Staple or braid together in back. Decorate with Indian symbols. Insert pieces of toothpicks into top and glue in place. Make two slits in back to insert pipe cleaner for loop.

Drill a hole for the neckerchief to slide through. Carve and shape the nose. Cut circles through the bark for eyes. Shape ears if any. Paint and varnish. Add string, leather, feathers, etc. for special effects.

### Walnut Shell Neckerchief Slide

Materials:

- Half a walnut shell
- Plaster
- Soda can tab
- Paint
- Black yarn
- Paper feathers

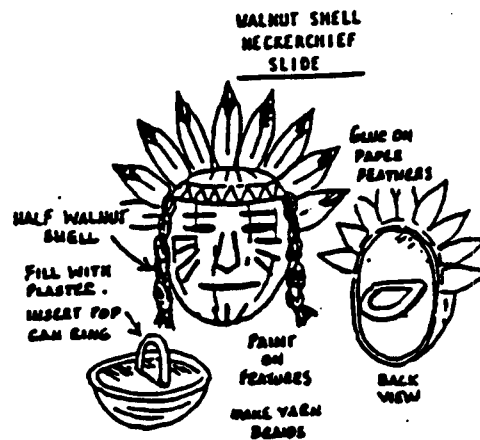

Take half a walnut shell and fill with plaster of Paris. While partially set insert soda can tab. Make two yarn braids and glue to sides of walnut. Paint face features. Make and glue paper feathers.

### Rawhide

This slide is made from ash twigs that are lashed together as shown. A thin piece of rawhide or vinyl is laced with thin cord to the ash twigs. Any picture that is Indian related would look nice painted on the rawhide. Use a hot glue gun to anchor the twigs together before lashing. Fasten thin wire loops at the top and bottom to use as the loop to hold the neckerchief.

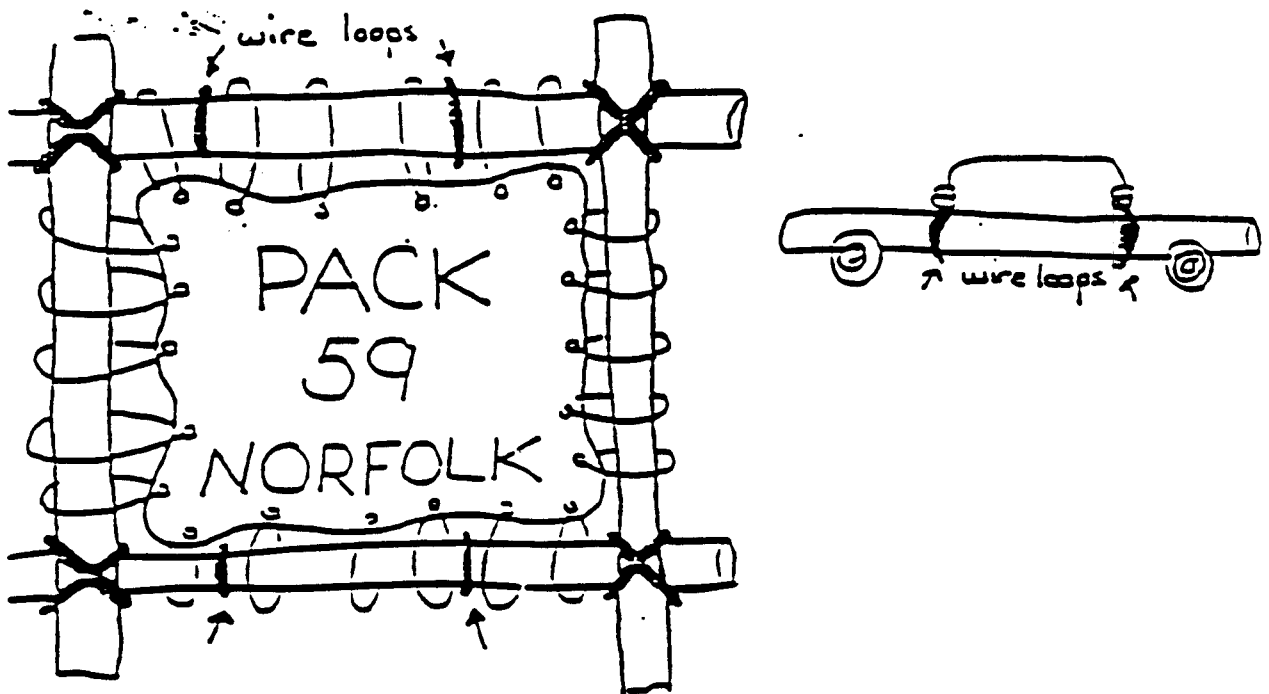



## Fishing Kit

### Materials:

- 1- 35 mm plastic film can
- 20' good fishing line
- 2- 3/4 hooks and 2 lead weights
- small cardboard and tape
- A fishing fly or fish stickers

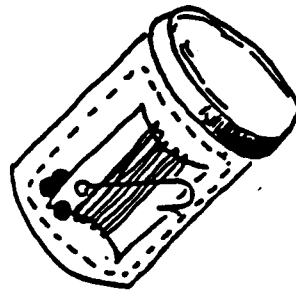

Cut the cardboard to fit the diameter and height of the film can. Cut a curve on each end of the cardboard to aid in holding the fishing line. Prepare the line with a hook and weight. Tape the end of the line to the cardboard loosely so it will not collapse. Secure the sharp end of the hook under the line. Tape the extra hook and weight inside the can. Epoxy a 1/2" x 1/2" piece of PVC pipe to the back of the film can and decorate the can with a fly or fish stickers as desired by the boy. When fishing the can slide serves as a bobber too, when snapped over the line.

## Fly Swatter Neckerchief Slide

Cut plastic canvas using the pattern. Cut a piece of floral wire about 6 inches long. Bend the wire in half and twist the open end using pliers. Glue to the back of the plastic canvas with glue gun. Glue a pipe cleaner ring to the back for neckerchief to go through. Make a fly using craft foam and 3 small pieces of wire (beading wire). Glue fly to front of the plastic canvas to cover wire showing through holes.

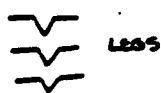

LEGS

○ BODY  
BLACK CRAFT FOAM

△ WINGS -  
CUT 2 FROM WHITE CRAFT FOAM

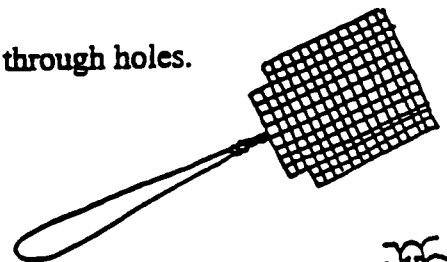

## Insect Display Case

### Version #1

Use a clear plastic pill bottle with a snap-on lid. Using pliers, hold a nail over a flame on the stove until it is hot. Use the hot nail to punch two holes on one side of plastic bottle, about 1/2" apart. Make a 3-1/2" ring from a pipe cleaner and insert in holes. Twist pipe cleaner on inside to secure it. Then with a hot needle, punch air holes in the lid of the pill bottle. Put in a little bit of sand and a twig. Now you are ready to catch a creepy, crawling specimen to put inside your display case. This is a really unique slide. You can change the contents of your display case whenever you wish.

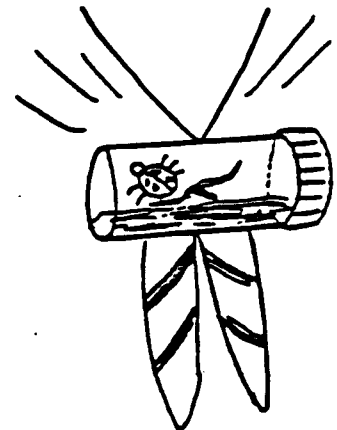

# RECYCLING

## Juice Can Tie Slide

### Materials:

- Juice can (5.5 oz best size)
- 12" leather lace (or substitute)
- Pony beads

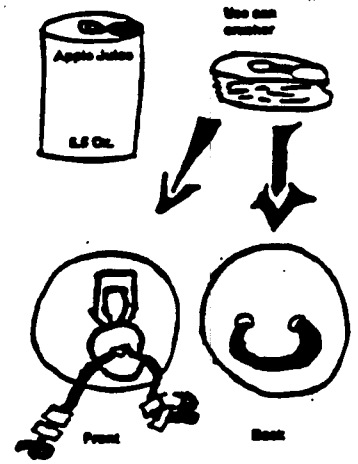

Crush can using a can crusher. File any sharp edges away. Punch 2 holes in bottom of can. Thread leather strand through holes and out front. Leave loop in back for neckerchief to run through and tie off in the front. Add beads to the strands.

## Litter Basket

### Version #1

Use a clear plastic 1 oz. Cup. Make holes for a pipe cleaner ring on the back with a hot nail or needle. Use a fine tipped marking pen to make crosses on inside of cup. Make a little sign with paper to glue on front. Fill basket with wadded paper scraps.

You can also make a litter basket slide using the small plastic "JET DRY" baskets from the dishwasher.



### Version #2

This slide is made from a plastic cup. The cup is jigger size. The bottom is cut out just large enough to let a neckerchief slip through but small enough so that the slide doesn't slip off. Cover the cup with aluminum foil. Take a small piece of wire and attach to rim for handle.

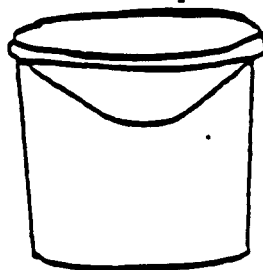

### Version #3

This wastepaper neckerchief slide is made from a jigger size plastic cup. The bottom is removed to let the neckerchief slide through. Cover the cup with gray paper and print "EVERY LITTER BIT HURTS YOU" on front.

# SEA / WATER

## Life Preserver

On a piece of Styrofoam about 1/2" thick, draw a 3" circle and cut out. From the center of the circle, remove a 2" circle. Loosely wrap cord around edge of Styrofoam and bind in place, as shown, with red cloth tape. Print "Cub Scout" on one side and "Pack No. \_\_\_\_" on the other. Insert and glue ends of a piece of white chenille into back for ring.

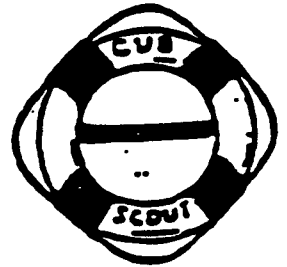

## Octopus Tie Slide

### Materials:

- Half walnut shell
- 2 wiggle eyes
- 4 black or gray pipe cleaners
- Plaster of Paris or hydrocal
- Glue
- 1 Plastic curtain ring or soda can ring

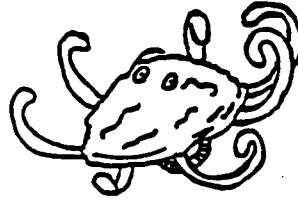

1. Pour plaster in the nut shells and insert soda can ring.
2. Cut 4 pipe cleaners in half. Bend the ends and insert them into the plaster around the edges.
3. When dry, paint the nut shell black for the body.
4. Glue on the eyes and bend and roll ends of the "legs".
5. Reinforce the pipe cleaners with glue where wires go into plaster.

## Plaster Slides

Pour plaster as specified on the package into candy molds. Add ring immediately. Using a wet mold will make the slide easier to remove from the mold. Spray plaster with a sealant before painting to keep the paint from soaking in.



## Sea Serpent Tie Slide or can be used as Snake

### Materials:

- 2 pipe cleaners
- String
- Dowel or pencil or something round
- Markers

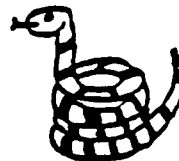

1. Twist the ends of two pipe cleaners together.
2. Double one end back to shape head.
3. Add a string tongue.
4. Wrap remainder around and turn end up for a tail.
5. Add dots for eyes and dab colored ink along body.
6. Glue rings together for added stability, if needed.

### Snorkel & Mask

#### Materials for Snorkel:

- Flexible straw that bends on one end
- Round bead
- Craft foam for mouth piece

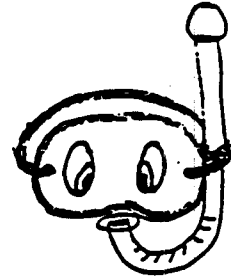

Cut a mouth piece from the craft foam. Put a drop of hot glue on the back of the craft foam. Tweezers will make handling easier. Set on end of bent straw and press the center until dry to give a concave effect.

#### Materials for Mask:

- Shrink art sheet
- Twist tie or pipe cleaner for band

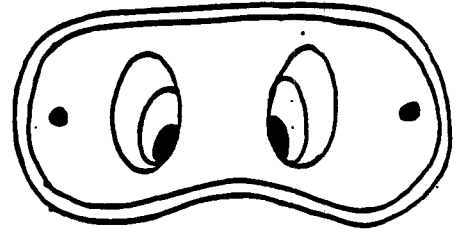

Outline pattern with a permanent marker or paint pen (sharpies work best on this material). Use a wide line. Use a colored pen to fill in eyes. Use black to outline eyes and for pupil. Cut out pattern and punch holes on sides with hole punch. Bake in oven according to directions on shrink art package. Use pipe cleaner or trash bag twist ties for band to attach to holes.

### Surfboard Tie Slide

#### Materials:

- 1- .25" x 3.25" x 1.25" pine
- Paint- red, yellow
- Tape
- Glue
- Sandpaper
- 1- .5" x .5" PVC pipe



1. Cut out shape
2. Sand smooth.
3. The skeg is made separate and glued in place.
4. Paint yellow.
5. Then tape of the yellow and paint the outside red. (Other colors and designs can be substitute)
6. Attach the PVC pipe to the back to form the loop.

### **Yacht Tie Slide**

The hull is whittled from white pine or balsa. The mast is a burned match. The boom is a toothpick. The sail is a triangle of white or red fabric.

1. Whittle and sand hull. It is flat on the back and curved on the front.
2. Drill 3 holes —one in the top for the mast....two in the back for metal ring cut in half.
3. Glue mast in place. Glue boom to lower edge of sail.
4. Glue sail to boom and mast and let dry.
5. Glue ring in place. While it is drying, make a small flag for the stern from construction paper and glue to a straight pin.

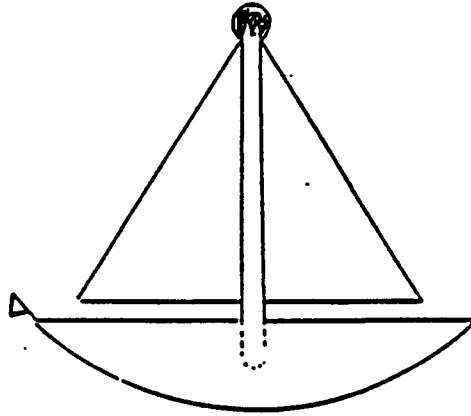

# SHOW TIME

## Cub News Action Cam Tie Slide materials;

- 1- 2" x 3" block of wood
- 1- .25" x 7" dowel
- Paint
- marker
- Glue
- Sandpaper
- Drill with a .25" bit
- 1- .5" x .5" PVC pipe

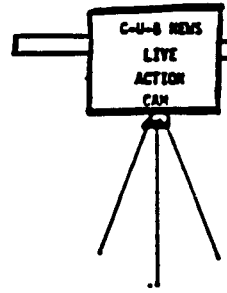

1. Drill a hole through the block of wood, top half.
2. Glue the dowel rod in place as illustrated. (Shorten if necessary to look like a camcorder)
3. Sand smooth
4. Paint as desired.
5. Letter as desired.
6. Attach PVC pipe to the back to form the loop.

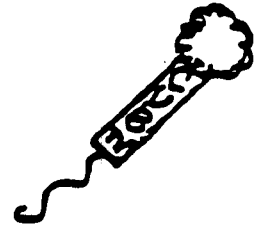

## Microphone Slide

Color 1/2 craft stick, black. Glue on 3/4" black pom-pom to top. Glue 4" black string to bottom. Make a pipe cleaner loop and glue on back just under pom-pom. Put white 1/3" transfer letters on craft stick. Spray with clear enamel or clear acrylic to seal- keeps letters in place.

## Ticket

Cut a "ticket" from thin wood. Paint or decorate with permanent marker. Add ring.



## Cub Theater

Cut tongue depressors into four equal pieces. Glue together to form frame. Paint and allow to dry. Add a cardboard square to the back. Paint sign on wooden shapes. Make character from pipe cleaner with beads. Glue character in place. Glue tissue paper or material curtains in place. Add ring.

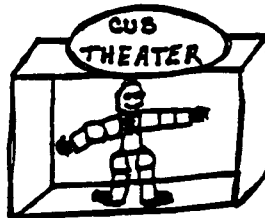

## Theater Masks

Cut masks shapes from plastic lid, wood, craft foam, or shrink art. Paint white and draw faces with permanent marker. Place pipe cleaner on back.

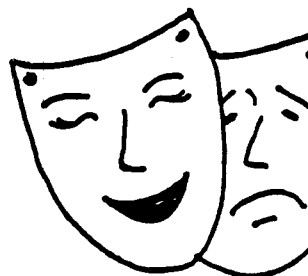

# TRANSPORTATION

## Airplane

### Version #1

Use wooden peg clothes pin. Add craft stick wings. Add a tail of a piece of craft stick. Add a toothpick propeller. Paint if desired. Add ring.

### Version #2

#### Materials:

- 1 snap clothes pin
- 2- ½ piece of pipe cleaner
- 1" piece of pipe cleaner
- 1- ½ craft stick

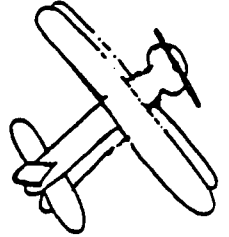

1. Remove wire snap.
2. Turn two wooden pieces backwards.
3. Place the 2- ½ piece of pipe cleaner in the small indentation.
4. Glue two wooden pieces together.
5. Glue small 1" piece of pipe cleaner to nose.
6. Glue craft stick for wing and ½ craft stick for tail piece in place.
7. Paint or color to please.
8. Pipe cleaner is twisted together at the back of the plane for the neckerchief slide loop or instead of the pipe cleaner a piece of leather could be glued on.

## Pinewood Derby Tie Slide

### Version #1

Cut out car of contrasting color and glue vinyl backing. Brads are used for wheels. Racing flags are decals.

### Version #2

#### Materials:

- Scraps of material, such as felt
- Vinyl circles
- Brads
- Decals

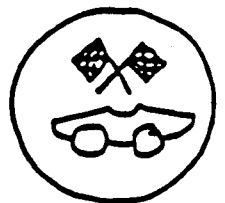

Cut out car from contrasting color and glue on vinyl backing. Cut vinyl strip and fasten to make ring on back. Use brads for wheels. Racing flags are decals.

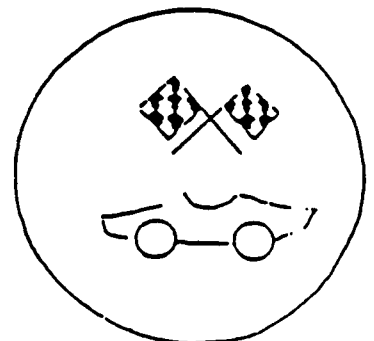

### **Version #3**

#### **Material:**

- Plastic candy molds in shape of a car
- Hot glue (colored if possible)
- Paint
- Twist Tie or PVC ring

Fill candy mold with hot glue. Press twist tie or PVC pipe in while glue is still hot. When it is cooled down pop it out of mold. If not using colored glue paint.

### **Version #4**

1. Cut ends from a clothespin half by clamping to a stable object and cutting with a hacksaw or other fine bladed saw.
2. Sand smooth.
3. Paint if desired.
4. Glue wheels to car (4 black pony beads)
5. Glue a ring to one side for slide.

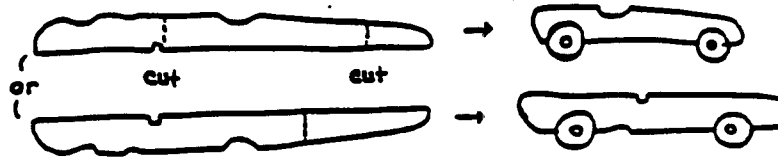

### **Version #5**

#### **Auto Slide**

Cut a car body from thin wood. Paint. Add wooden shapes: circles for headlights, an oval for the grill, a rectangle for the license plate. Paint a hood ornament, rectangles are the tires. Mark the tread and grill with a marker. Draw a steering wheel and number the plates. Add a ring to the back.

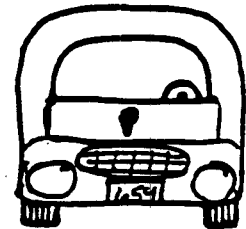

#### **Propeller Tie Slide**

#### **Materials:**

- 26" long plastic strips
- 1 brad
- 1 plastic trash tie or twist tie

1. Cross the strips.
2. Put the tie underneath and slip the brad through the three pieces.
3. Use the tie to adjust for size.

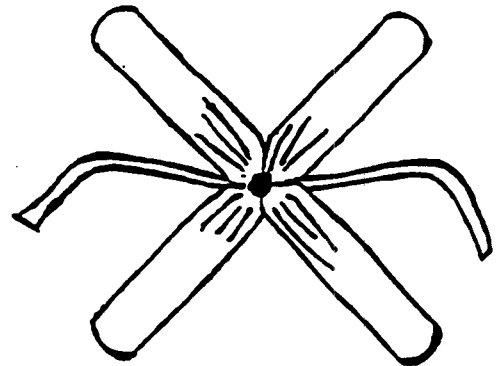



## Suitcase Tie Slide

### Materials:

- 1 Block of wood
- 1 Horseshoe shaped piece of wood or horseshoe staple
- Sandpaper
- Glue
- Paint
- Clear acrylic spray
- 1- .5" x .5" PVC pipe

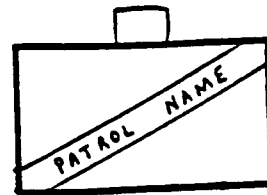

1. Shape the block of wood to look like a suitcase.
2. Add the handle.
3. Sand smooth.
4. Paint or design as desired. Use your imagination.
5. Spray with acrylic finish.
6. Attach PVC pipe to the back to form the loop.

## Traffic Light

Draw lines with pencil. Brads are used for lights. Paint brads red and green. Vinyl strip to make ring for slides.



Vinyl strip to make ring for slides



## State Slide

### Materials:

- 1/4" wood thin pine/ birch plywood
- Xerox copy of your state about 2" in size.
- Carbon paper for tracing or glue
- Leather strips 1/4" x 3"
- Nails or staples
- Paint or markers
- Acrylic spray/ clear contact paper

1. Trace your state onto the wood or glue it on.
2. Cut it out with coping saw or with a power scroll saw.
3. Paint or use markers to color state.
4. Spray with acrylic or put clear contact paper on it to prevent colors from running.
5. Staple or nail leather on back for loop.

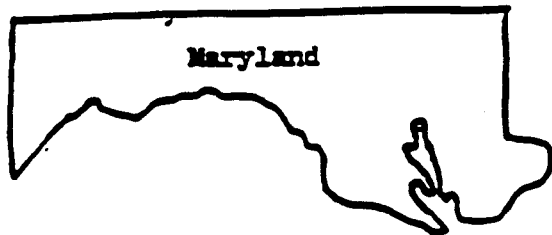
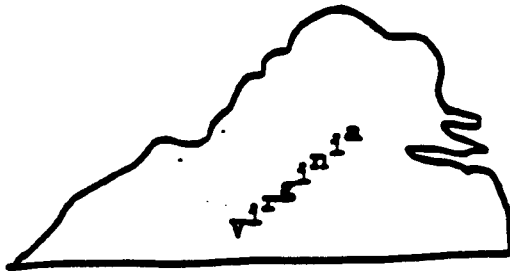

## Windsock Slide

*Important: You must use lightweight material, (nylon, crepe, ECT.) So it will flutter.*

### Materials:

- 3" x 3" Lightweight material
- 1/2" x 3/4" PVC pipe
- Glue
- 2" pipe cleaner
- Waterproof markers.

1. Drill two holes in the PVC pipe about 1/2" apart to insert the pipe cleaner in the end.
2. Cut a 2" fringe along one side of the material.
3. Sketch a picture on the top portion with markers.
4. Let dry.
5. Glue the uncut top around the PVC pipe.
6. Glue the pipe cleaner into the pre-drilled holes in the PVC pipe.

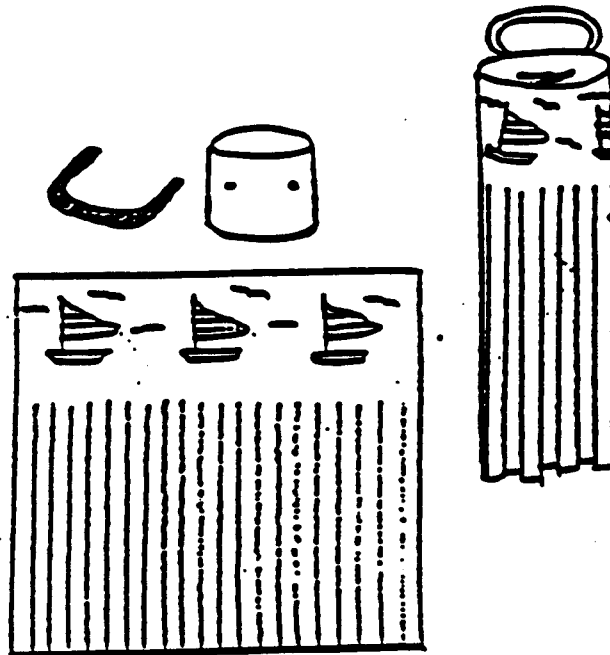

# WEATHER

## Kite Slide

### Version #1

#### Materials:

Cardboard  
Yarn and pipe cleaner  
Glue and scissors

1. Cut shape as shown from cardboard 2-1/2" each side.
2. Decorate.
3. Add yarn tail with cardboard bows.
4. Thread pipe cleaner through middle (with loop at back).

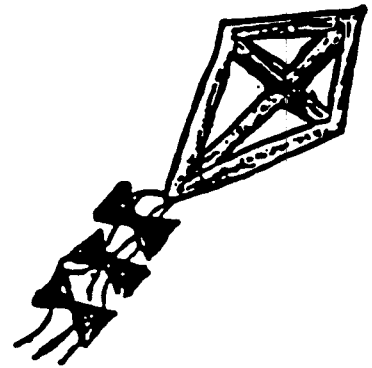

### Version #2

#### Materials:

1- 2" square of Fun foam (any color).  
2- wooden toothpicks  
1- 4 " piece of embroidery floss  
1 3-1/3" x 1/4" strip of suede leather

1. Cut Kite pattern from Fun foam.
2. Glue toothpicks crosswise on Fun foam.
3. Cut points off toothpicks to proper length for kite.
4. Tie 4 knots in embroidery floss and glue to Fun foam for tail.
5. Glue ends of suede leather to form a ring, and glue to the reverse side of kite.

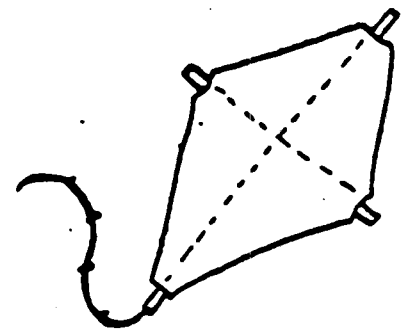

## Lightening Bolt

Cut a cloud from heavy cardboard. Paint. Add a pipe cleaner handle. Add ring.

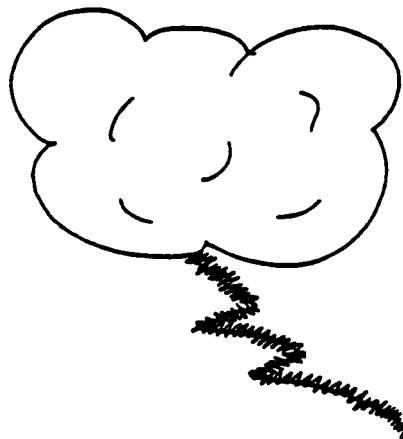

# CRAFTS

# HOW TO MAKE BIRTHDAY CUBE GIFT BOX



## Here's what you need -

Computer paper, scissors, glue, crayons or markers



## Before you start -

1. Make a place to work. Protect the table with a big sheet of paper.
2. Get everything you need to do the project.
3. Read all the directions.
4. Think about the project. Imagine how it will look and what you will do with it.

Are you ready? Okay, get started!!!

## Step 4 - Fold Lids and Flaps

Turn the box with the colored side down. Fold lids, lid flaps, and box flaps in on the black lines. Flatten the box out again.

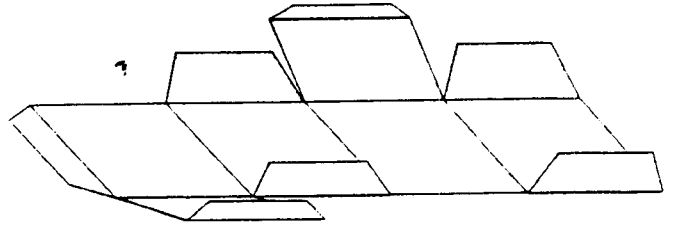

## Step 1 - Print

Click on the Print button to print Birthday Cube Gift Box.

There is one piece on the page. The four rectangles in the center are the box sides. The glue tab is at the end of the row of sides. The other two boxes are the top and bottom lids. Each of these boxes has one flap attached. Two of the sides have a pair of box flaps attached.

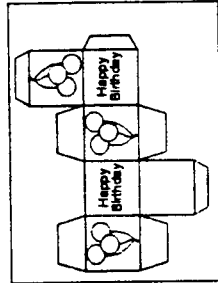

## Step 5 - Fold Sides and Glue Tab

Keep the colored side down. Fold the glue tab in on the black line, then flatten it. Fold each side in on the black line, then flatten it.

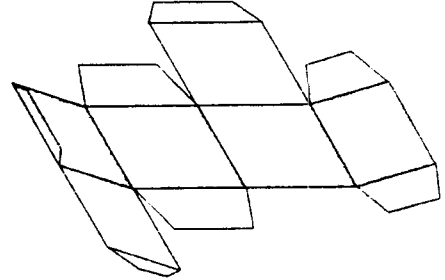

## Step 2 - Color

Color the box with any colors you like. The box flaps, lid flaps, and glue tab do not need to be colored.

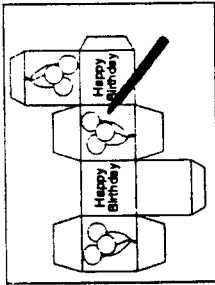

## Step 6 - Glue

Put glue down the entire length of the glue tab. Shape the sides into a box shape and glue the tab to the inside of the last side.

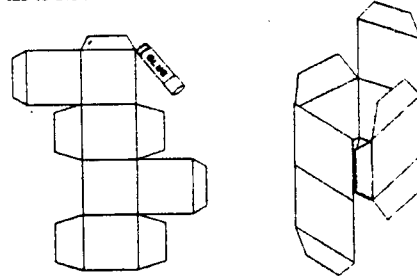

## Step 3 - Cut

Cut around the box on the solid black lines. Try to make your cuts very straight. The box will be stronger and go together better if the cuts are very straight.

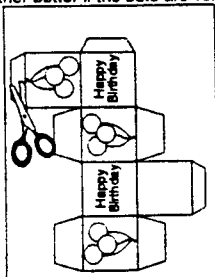

## Step 7 - Close Lids

To finish your box, fold the bottom flaps in and close the bottom lid over them. Tuck the bottom lid's flap inside the box. Repeat for the top lid.

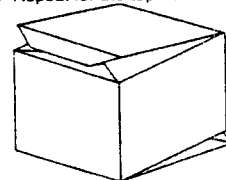

What are you going to put in your box? Make some tiny toys to put in the box by selecting the Tiny Toys option in this project. Or, the rhinoceros and bighorn sheep puppets fit into the cube.

The End

# Happy Birthday Cube Gift Box

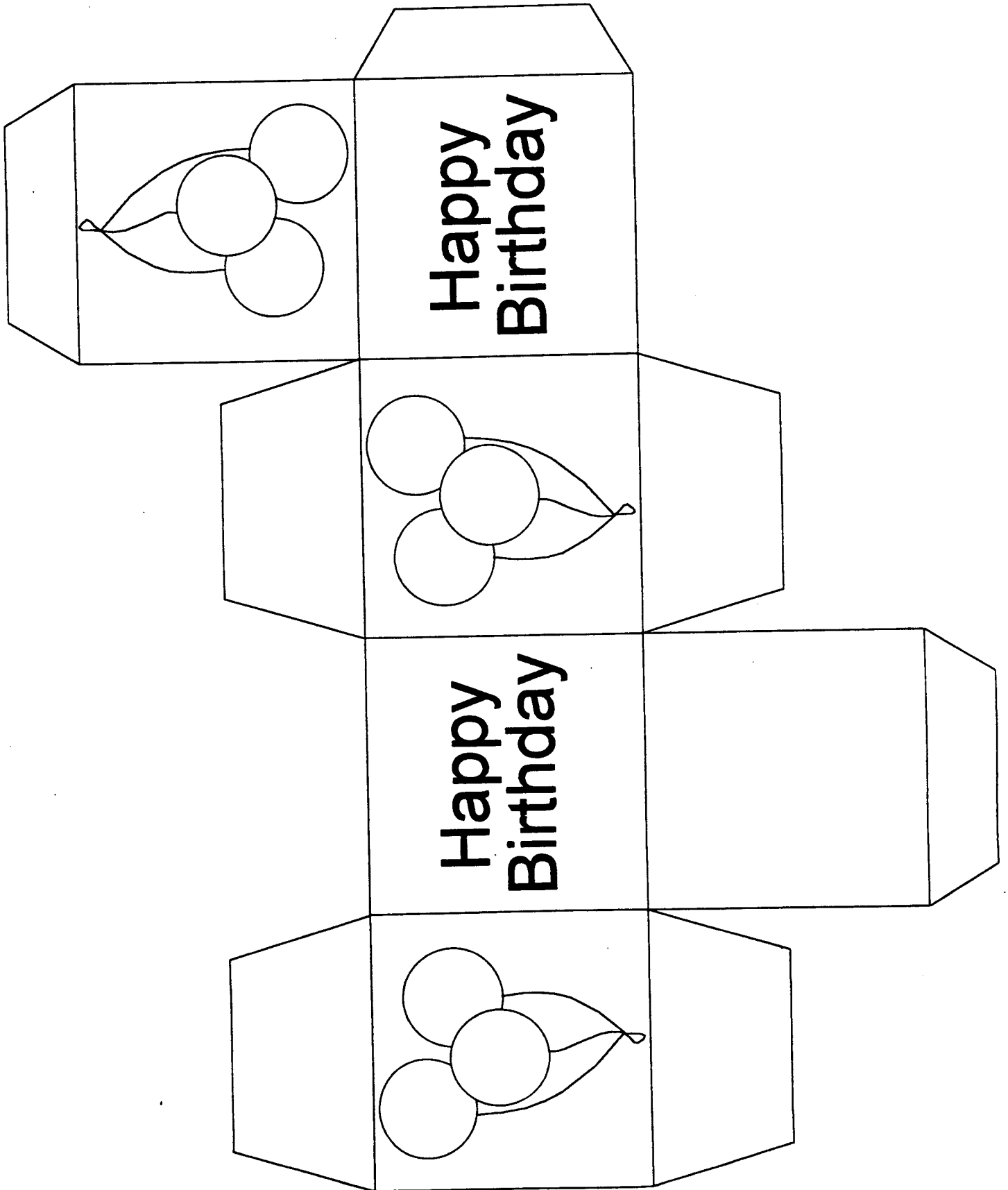

# HOW TO MAKE DAISY IN PLAIN VASE



## Step 4 - Fold and Cut

Fold the flower and stem parts in half on the dashed line. For each part, cut around the shape (do not cut along fold). Now, open the part flat and trim around the edges, if needed.

With just one cut you made both sides of these shapes the same.

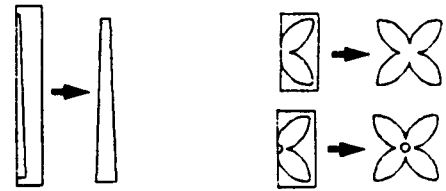

What other shapes can you make by cutting paper that is folded in half?

Here's what you need -

Computer paper, scissors, glue, crayons or markers.



Before you start -

1. Make a place to work. Protect the table with a big sheet of paper.
2. Get everything you need to do the project.
3. Read all the directions.
4. Think about the project. Imagine how it will look and what you will do with it.

Are you ready? Okay, get started!!!

## Step 1 - Print

Click on the Print button to print Daisy in Plain Vase. You will have five patterns - two flower parts, stem, and two vase parts.

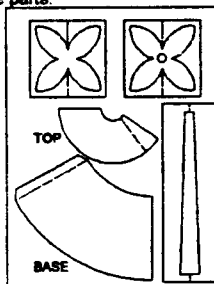

## Step 5 - Glue Flower

The flower has two flower parts. The one with the circle in the center goes on top. Put glue in the middle of the bottom flower part. Attach the two flower parts at the centers. Next, glue the stem to the center of the flower back.

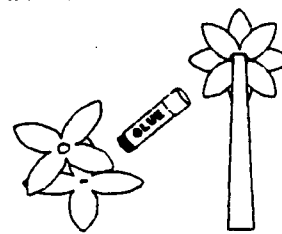

## Step 2 - Color

Color each pattern piece. These are daisies which are usually white or yellow with black centers. Or choose any colors you like.

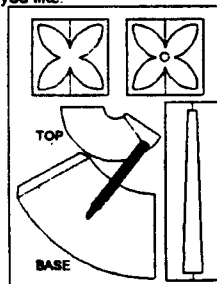

You don't need to color the glue tabs on the vase parts.

## Step 6 - Glue Vase

To form the vase base, put a small amount of glue on the glue tab. The glue tab is marked by the dashed line. Form a cone shape by overlapping the other edge to the dashed line. Do the same for the vase top.

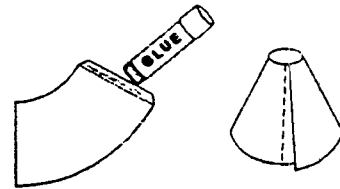

## Step 3 - Cut

Cut around each pattern piece on the solid black line. For now, just cut out the boxes around the flower and stem parts.

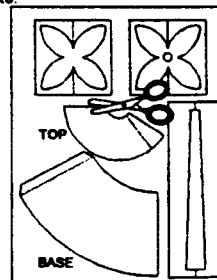

## Step 7 - Put It Together

Insert the small end of the top piece into the small end of the base. You can glue the two pieces together. Put glue around the outside of the top where it joins the base. To finish, insert the stem and flower into the vase. Fold the stem to fit it into the small hole.

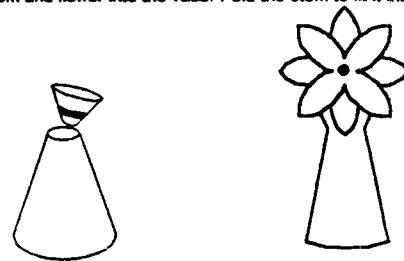

The End



# Daisy in Plain Vase

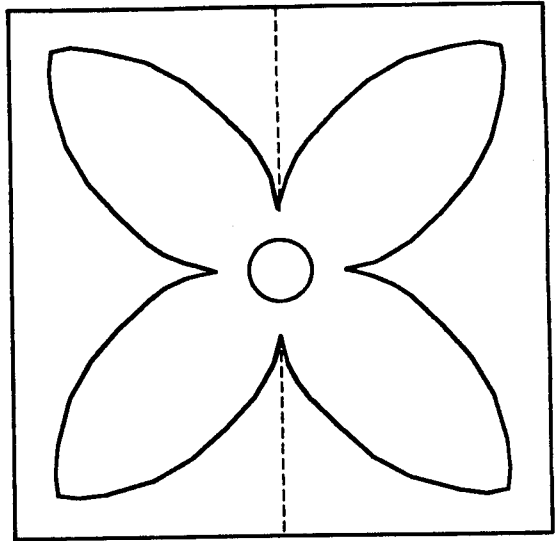
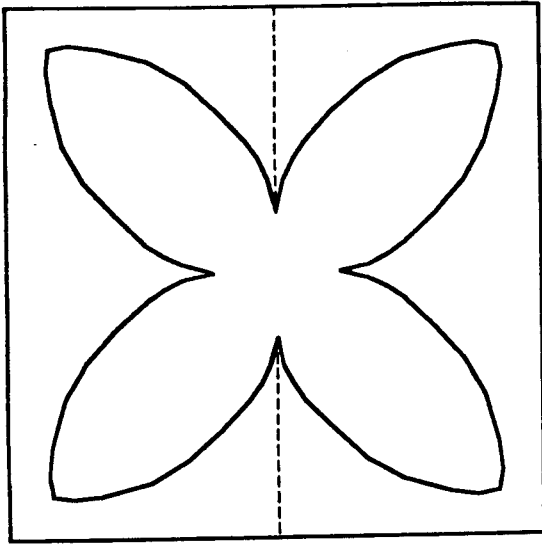

**TOP**

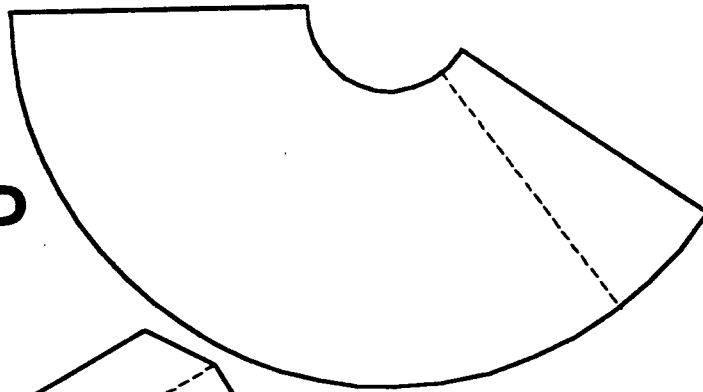

**BASE**

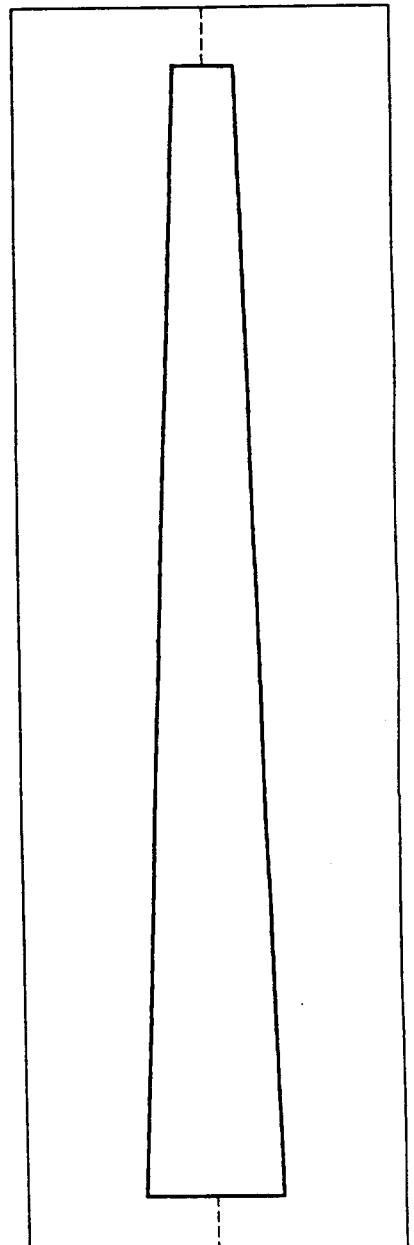
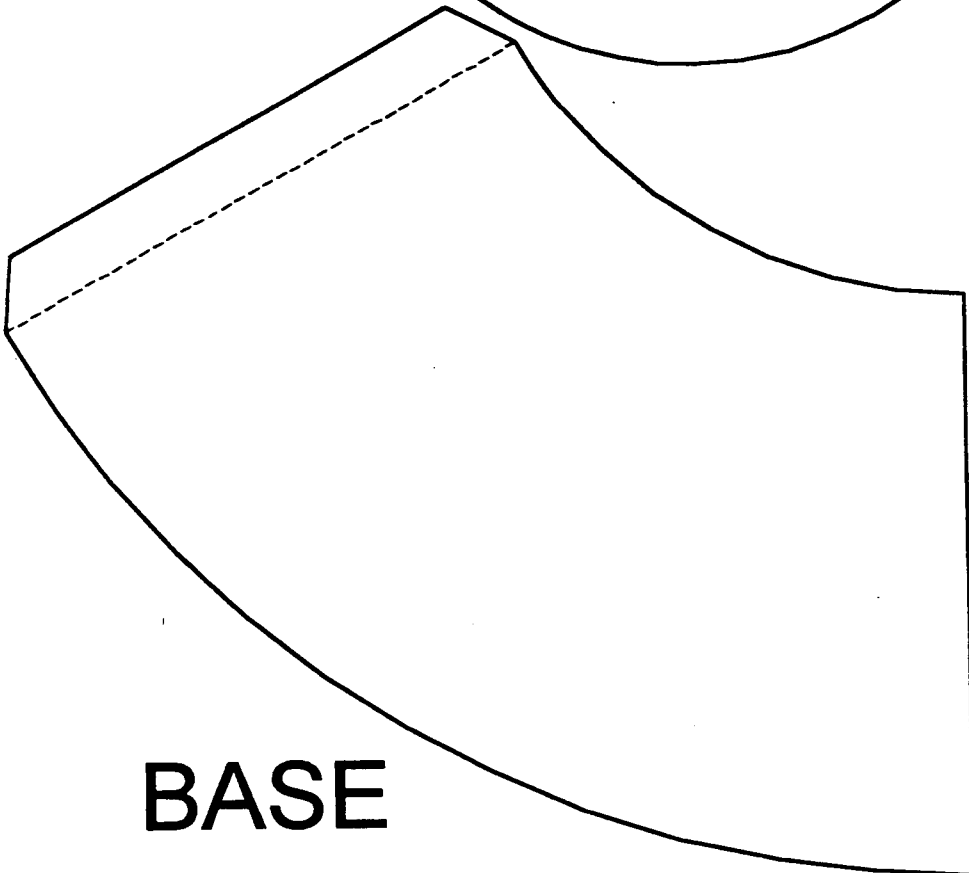

# Reversible Placemat

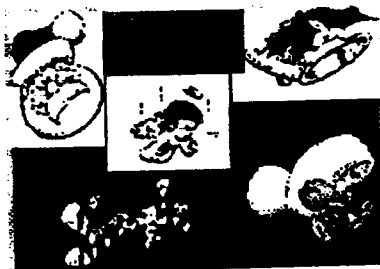

## Supplies needed:

- Fronts of old cards (Christmas, birthday, all occasion)
- Wrapping paper -
- Gold bric-a-brac (or any color you choose)
- Glue or glue gun
- Clear contact paper - 18" wide

## Instructions:

1. Cut one sheet of wrapping paper - suggested size: 12" x 18". This will be the back of the placemat.
2. Trim fronts of cards.
3. Lay wrapping paper face down on a flat surface.
4. Arrange cards on reverse side of wrapping paper, overlapping them in a random pattern, being sure to cover the entire sheet.
5. When you have arranged the cards the way you like them, glue them in place and allow to dry. This is now the front side of the placemat.
6. Glue bric-a-brac around the outside edges of the front of the placemat and allow to dry.
7. Cut two pieces of clear contact paper, each bigger (at least 1/2") than the wrapping paper on all sides.
8. Place the back side of the placemat to the sticky side of the contact paper. Be sure to smooth out all bubbles.
9. Place the front side of the placemat to the sticky side of the other piece of contact paper.
10. Tightly press all edges of the contact paper together to seal the placemat.
11. Trim edges of contact paper allowing a 1/4" margin around the finished size of placemat.

**You're done!** Your placemat is easy to wipe off with a wet cloth.

## Some variations:

1. Have your child draw a picture or write his/her name on a large sheet of paper instead of using wrapping paper.
2. Use a favorite picture from a magazine or poster.
3. Substitute photographs instead of cards.

# Kid's Christmas Bells

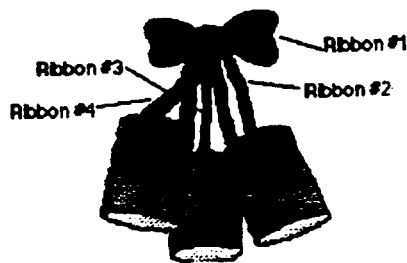

These Christmas bells are so easy to make and so much fun! Kids will have a great time making decorations for themselves or as gifts!

## SUPPLIES NEEDED

- 3 styrofoam or paper cups (any size, preferably small)
- aluminum foil
- 3 small bells
- Any color ribbon (crinkled gift wrapping ribbon is the easiest to work with)
- Pencil (or other sharp object to poke a hole)

## INSTRUCTIONS:

1. Wrap each cup in aluminum foil, covering the entire outside and as much of the inside as possible.
2. With a pencil or other sharp object, poke a hole in the center of the bottom of each foil-covered cup. The hole should be big enough to insert the ribbon through the hole, but small enough so that the bells won't slip through it.
3. Cut a piece of ribbon long enough to tie a bow at the top with enough ribbon left over to make two tails. (Ribbon #1).
4. Cut three more pieces of ribbon in different lengths so that the bells will hang to different lengths.
5. Tie one end of Ribbon #2 to the center of ribbon #1.
6. Repeat Step 5 with Ribbons #3 and #4.
7. Tie Ribbon #1 into a bow, using the center where all the ribbons join as the center of the bow.
8. Trim the ends of Ribbon #1 into a "V" shape by folding the ribbon in half at the end; then cutting a small triangle off the end, starting at a corner. (If you prefer, you can just snip off the end on a diagonal cut without folding.)
9. Thread the untied end of Ribbon #2 through the hole in one of the cups.
10. Continue threading Ribbon #2 through one of the bells and tie a knot.
11. Repeat Steps 9 and 10 with Ribbons #3 and #4 and the remaining cups.

10/4/98

## Washable Finger Paints

This recipe makes a paint that washes easily and feels nice and soft. It mixes better at room temperature.

### Materials:

- 2 tablespoons liquid tempera paint
- 1 tablespoon powdered gentle detergent soap
- 1 cup LINIT® Liquid Starch

*CHILDREN REALLY LOVE  
THIS PAINT.  
IT'S FUN TO USE!*

### Process:

1. Mix LINIT® Liquid Starch and soap in a bowl.
  2. Slowly add paint. (Use more tempera for a stronger, more brilliant color.)
  3. Mix well with whisk until all soap is dissolved.
  4. Store in covered container.
- 

## Easy Starch Paste

Quick and easy to prepare. this starch paste will keep for a few days. Store in a covered container to prevent thickening.

### Materials:

- 1 cup LINIT® Liquid Starch
- 1/2 cup flour

### Process:

1. Pour flour in a mixing bowl.
2. Slowly add LINIT® Liquid Starch to the flour.
3. Mix with whisk until smooth.

## Ornaments

Simple but beautiful ornaments can be created by layering bits of colored tissue paper. The finished product has a glossy shine and a stained glass effect. Hang them in windows so the light filters through the colors.

### Materials:

- Assorted colors of tissue paper
- Wax paper
- String or yarn
- Scissors, paintbrushes and hole punch
- LINIT® Liquid Starch

*GREAT HOLIDAY GIFTS  
AND A PERFECT  
PROJECT FOR CRAFTERS  
OF ALL AGES!*

### Process:

1. On a sheet of wax paper, paint a layer of LINIT® Liquid Starch.
2. Place different colors of tissue paper on the wax paper base, overlay papers to create different colors.
3. Paint with more LINIT® Liquid Starch and add a second layer of tissue paper.
4. Allow to dry. Then peel away wax paper.
5. Cut into creative shapes. [TIP: Use fun cookie cutters to trace shapes!]
6. Punch a hole and add string, ribbon or yarn for hanging.

## Treasure Boxes

An ordinary crafters paper box can be transformed into a lovely treasure box. Store jewelry, change or special keepsakes inside.

### Materials:

- Paper box (light cardboard) any size
- Tissue paper in assorted colors
- Cut-out pictures [TIP: seed catalogs offer great possibilities]
- LINIT® Liquid Starch
- Aluminum foil
- Paint brush

*USE YOUR IMAGINATION IN  
COLORS AND PATTERNS  
AND MAKE A TRULY  
PERSONAL STATEMENT!*



**Process:**

1. Tear the tissue paper and/or pictures into small pieces. (You choose how many you want to use, and how small you want the pieces to be.)
2. Paint the box with undiluted LINIT® Liquid Starch.
3. Apply the paper (and pictures if you are using them) randomly.
4. Apply a coat of LINIT® Liquid Starch.
5. Allow the box to dry overnight on an aluminum covered tray.
6. Top with ribbon, silk, or dried flowers for an even fancier look.

[TIP: You may want to cover the inside, too!]

---

## "Stained Glass" Candle Holders

Crafters of all ages can create a lovely, unique finished product within a half hour. It makes a wonderful gift!

**Materials:**

- Clear glass container (jar, small glass)
- Tissue paper in assorted colors
- LINIT® Liquid Starch
- Paint Brush
- Votive or tea candle, depending on size of container



HOW CAN ANYTHING  
SO BEAUTIFUL BE  
SO EASY TO MAKE?

**Process:**

1. Tear the tissue paper and/or pictures into small (1") pieces.
2. Paint the container with undiluted LINIT® Liquid Starch.
3. Apply the tissue paper to the container with your fingers, overlapping to create different colored effects.
4. Once the container is covered, apply a coat of LINIT® Liquid Starch over all the pieces.
5. Allow the container to dry overnight on an aluminum covered tray.
6. Place the candle in the container.

[TIP: Try using red, green, and gold tissue paper for Christmas candle holders. Group several on your mantel or table centerpiece for a fabulous, festive look.]

## Yarn Net Molds

There are many projects you can make for every season. These mold nets can be used as holiday ornaments, window decorations, centerpieces, and more.

Small, delicate net molds, strung with ribbons or yarn, can be used for Christmas tree decorations.

At Easter, using pastel colored yarn and small, oval-shaped balloons, you can create eggs for hanging or eggs for arrangement in a bowl or basket for use as a centerpiece. For a spring decoration, use brown twine and cover half of a round balloon, making a small twine nest. Fill the nest with tiny robin's eggs, little silk flowers or a feathercraft bird.

In autumn, fill your nest with colored leaves, nuts, or little plastic mushrooms. Hang multicolored balls of color in a sunny window all year 'round.

Since the wet yarn and balloons are slippery to handle, this project is recommended for older children with a bit more patience and dexterity than the younger ones have. Working in pairs would be helpful.

### Materials:

- Small balloons
- Petroleum jelly
- Yarn or string (Choose color(s) appropriate to your project.)
- LINIT® Liquid Starch in a bowl
- Wax paper

### Process:

1. Blow up the balloons to the desired size and knot the ends.
2. Coat the inflated balloon with a thin layer of petroleum jelly.
3. Cut the yarn into long pieces (approximately 2-3 ft.) and dip them into starch.
4. Starting at the knotted end, begin wrapping the starch-soaked yarn around the balloon at various angles. Remember that the idea is to create a net, so don't leave any big gaps.
5. Set the balloon on wax paper to dry.
6. When the yarn is completely dry (several hours or overnight) carefully pop the balloon and remove it.

---

# FUN THINGS

---

## Table of Contents:

Play Putty/Slime  
Making Paper  
Molded Paper Sculptures  
Marbling  
Stick Puppets  
Papier-Mâché Puppets  
Chinese "Rice Paper" Pictures

---

## Play Putty/Slime

It's fun for kids to play with, however, it can be a little messy. Cover your work surface with newspaper.

### Materials:

- 2 cups LINIT® Liquid Starch
- 2 cups white glue
- Food coloring

**IMPORTANT:** Because play putty/slime can be broken into small pieces and may present a choking hazard, this is not suitable for children under five years of age.

### Process:

Add a few drops of food coloring to white glue. Stir in LINIT® Liquid Starch, small amounts at a time.

Keep stirring until the mixture is smooth and rubber like. The dough should move away from the sides of the bowl and be sticky to touch.

Add a few more drops of starch to eliminate the sticky feel. It can be stored in an airtight container and refrigerated over night.



---

## Making Paper

In today's society, people are always looking for ways to recycle. This is a fun activity that recycles paper - you can make new paper from used paper.

### Materials:

- 10 sheets of newspaper
- A large pot
- 2 cups water
- A blender (or an egg beater)
- A deep pan, a little larger in area than the screen
- 2 tablespoons of LINIT® Liquid Starch
- A piece of screen (about 5 inches by 10 inches)
- Additional pieces of newspaper for blotting
- A round jar or rolling pin

### Process:

Tear the 10 sheets of newspaper into very small pieces. Place them in a large pot.

Pour in the water and let the mixture sit for a few hours, until the paper is soggy.

Blend the water and the soggy paper in the blender in small amounts, or mix them thoroughly with the egg beater or spoon. The mixture should have the consistency of oatmeal.

Pour the mixture into the pan and add LINIT® Liquid Starch. Stir for about 3 minutes.

Slide the screen under the pulp. Move the screen around until the pulp covers half of the screen. You can also spread handfuls of pulp on the screen. The pulp should be about 1/8 inch (3 mm) thick.

Lift the screen out carefully. Hold it level and let it drain for about one minute.

Fold the other half of the screen over the pulp and place it on several layers of newspaper. Put more newspaper on the top.

Roll the rolling pin or the jar over the newspaper "sandwich" to squeeze out the rest of the water.

Take off the top newspaper. Remove the pulp from the folded screen. It will be your paper!

Allow the recycled paper to dry overnight before you write on it.

---

## Molded Paper Sculptures

Instead of rolling the paper pulp described above into sheets, you can pack the pulp into clear candy molds of all shapes and sizes. Press the pulp deep into all areas of the mold. (The clear mold will enable you to see it easily.) Use a sponge to soak up extra moisture, then use a towel or paper towel and press firmly to remove as much water as possible. Let the pulp dry in the mold overnight. When the paper pulp is dry, press on the edges of the mold and push the paper sculpture out. You can leave the rough edges around the image for a handcrafted look or trim the edges with scissors. Your new sculpture may then be painted, decorated with ribbons, mounted and framed, or become part of a collage.

---

## Marbling

Marbling is a craft that is immediately gratifying. The freeform patterns and lovely colors that occur in marbling are dazzling. Traditionally found inside books to cover the binding, marbled paper can be used to make book covers, cards and add special charm to collages.

### Materials:

- LINIT® Liquid Starch (64 oz.)
- Tempera or acrylic paint
- Acrylic flow improver or liquid soap
- 9" by 12" tray or aluminum pan
- Eye dropper, comb, toothpicks
- Paper

*THEY'RE SO MUCH FUN IN THE  
PROCESS, THE END RESULT  
IS A BONUS!*

[TIP. Use a large piece of heavy paper and cover it with clear contact paper to make placemats!]

### Process:

<http://www.linit.com/fun.html>

10/4/98

Thin paint with water to the consistency of heavy cream. (Paints can be put in a muffin tin, baby food jars or other small containers.)

Add a few drops of acrylic flow improver to each color. (This is a spreading agent.) Or you can use liquid soap, however, use only a tiny amount to prevent bubbles.

Pour LINIT® Liquid Starch into tray.

Using an eye dropper, drip paint close to the surface of the liquid starch, being careful not to use too much. Experiment with different colors.

Use a comb or toothpick to gently pull the paint across the surface and create a design. Do not overwork the paint, as you may lose the marbling effect.

Hold the paper on diagonal corners. Bend it slightly so that the middle touches the surface of the paint and starch. Then slowly drop the paper.

Pick up the same corners and lift the paper straight up. Turn over and rinse off the excess starch in the sink. The marbled pattern will not disappear.

Allow to dry.

---

## Stick Puppets

Puppets are a wonderful tool for dramatization as well as language development. Children as young as five can make simple stick puppets. According to their stages of development they can elaborate on the basic puppet. Older children can make shadow or jointed puppets.

### Materials:

- Cardboard (shirt boards, cut up cartons, etc.)
- Collage materials (fabric, yarn, buttons)
- LINIT® Liquid Starch Paste (see recipe on "[Arts & Crafts Ideas](#)" page)
- Sticks
- Scissors

*YOU'LL BE SURPRISED AT  
HOW INVOLVED THE KIDS GET  
IN DOING THIS!*

**Process:**

1. Cut cardboard into various sizes and shapes. Large rectangles for bodies, smaller rectangles for heads and long narrow rectangles for legs, arms and tails.
2. Arrange the shapes to form an animal or person and paste shapes together.
3. Attach a stick to the base (body) of the puppet. Further secure with a piece of tape.
4. Decorate puppet with collage materials on both sides. (You can make the puppet different on each side).
5. Make sure stick has dried in place before playing with puppet.

[TIP: Place the finished puppet into the soil of your favorite house plant.]

---

## Papier-Mâché Puppets

**Materials:**

- Newspaper
- LINIT® Liquid Starch Paste (see recipe on the "Arts & Crafts Ideas" page)
- Toilet paper rolls
- Felt, yarn, plastic doll eyes, scraps of material
- Tissue Paper (assorted colors)

*CHILDREN MAY NEED A LITTLE  
HELP WITH THE HEAD BUT  
THEY WILL HAVE GREAT FUN  
DECORATING THE BODY  
THEMSELVES!*

**Process:**

1. To make the puppet head, crumple up a sheet of newspaper and shape with hands to form ball.
2. Wrap ball in another sheet, gathering all ends into your hand at the bottom. Twist.
3. Insert head into toilet paper roll.
4. Follow steps for papier-mâché to complete the head. (Arts & Crafts page).
5. When the head is completely dry, make puppet body out of cloth. For younger children, provide a paper pattern they can use to trace. Older children can create their own pattern.
6. Cut out a front piece and a back piece.
7. Sew or glue underarm and side seams.
8. Add felt hands.
9. An alternative body could be made from an old sock.
10. Paint a face and decorate with yarn for hair.

## Chinese "Rice Paper" Pictures

This is a great way to create semi-transparent paper artwork. Before beginning, determine if you want to make a representational image or an abstract design. You might want to cut out your shapes in advance. And remember, some overlapping colors look nice, too.

### Materials:

- 2 same size sheets of white tissue paper (aka art tissue) per picture
- Assorted pieces of colored tissue paper
- Wax Paper
- LINIT® Liquid Starch

### Process:

1. Place wax paper on the worktable.
2. Place a sheet of white tissue paper on the wax paper.
3. Brush a thin coat of starch on the tissue paper.
4. Arrange your various shapes of colored tissue paper on the white tissue paper.
5. Place another sheet of white tissue paper on top of the colored, creating a sandwich effect.
6. Coat again with the LINIT® Liquid Starch. Let it dry.
7. Peel the tissue away from the wax paper and you will have a beautiful "rice" paper image.



# Angel de Pasta

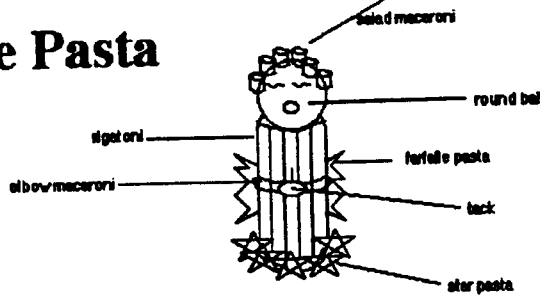

#24 rigatoni pasta - body



star pasta - hem



salad macaroni - curly locks



elbow macaroni - arms



wings - farfalle pasta



1" round wood ball - head



tack - candle and holder

## Supplies:

- white spray paint
- red nail polish
- black permanent marker
- glue gun or model cement

## Instructions:

- Set wood ball on one end of body (rigatoni) and glue.
- Glue hair (salad macaroni) to ball.
- Glue hem (star macaroni) along the bottom of body.
- Glue wings (farfalle pasta) to back of body.
- Glue arms (elbow macaroni) to front of body to hold candle.
- Glue candle and holder (tack) to point where arms meet.
- Spray paint entire angel white and allow to dry.
- Paint tip of candle red with nail polish.
- Paint mouth on face with red nail polish.
- Paint closed eyes with lashes on face with marker.

# EMERGENCY SIGNAL

For safety purposes, keep an emergency road signal in your car.

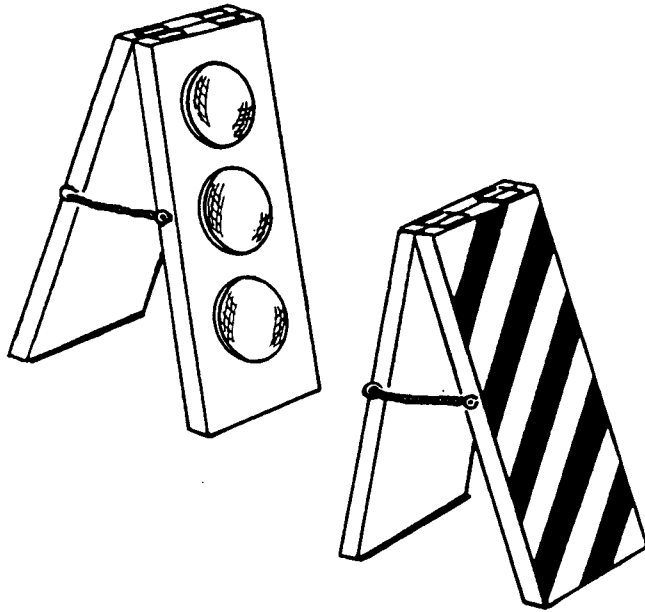

## ADVANCEMENT POSSIBILITY

Wolf Achievement 5: Tools for Fixing and Building

## MATERIALS

Two 1" hinges with screws

Two small screw-eyes

12" plumber's chain or wire

Reflector tape or glass reflectors

Screwdriver

Hammer

Two boards 4" x 24" x 3/4"

Sandpaper

## PROCEDURE

1. Cut the boards to right lengths and sand edges smooth.
2. Nail the reflectors to one side of each board or apply reflector tape in several strips on each board.
3. Using a screwdriver, screw the hinges to the top of both boards.
4. Measure 8" from the bottom of each board and then screw in a screw-eye at that point. Attach the plumber's chain or wire between the eyes.

If your car breaks down at night, place the emergency signal on the highway a reasonable distance in back of the car.

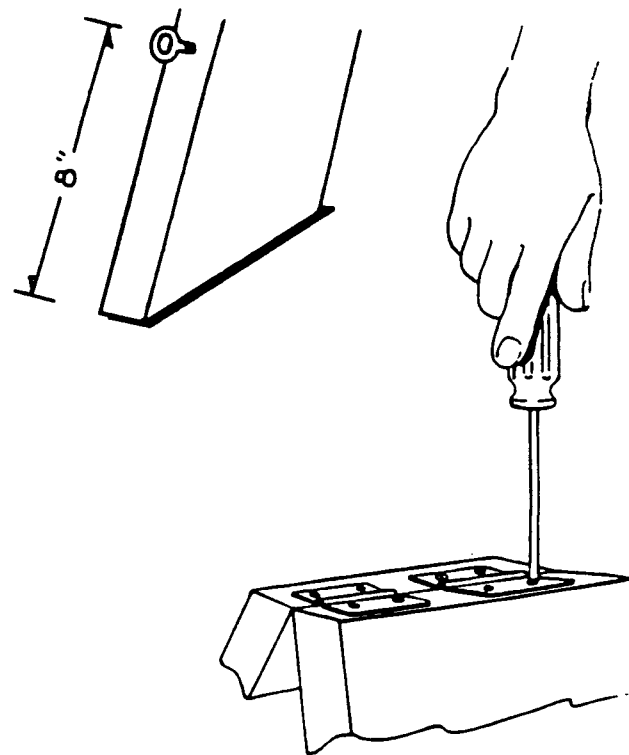

## Desk Organizers

Can't find a pencil when you need?  
Need an envelope, fast? Wonder where  
the gas bill disappeared? Sounds like  
your desk is a mess. What it needs is a  
little organization and here's a simple  
way to do it. They're quick and easy to  
build and can be as small or large as  
you want, depending on your needs and  
your desk or table size.

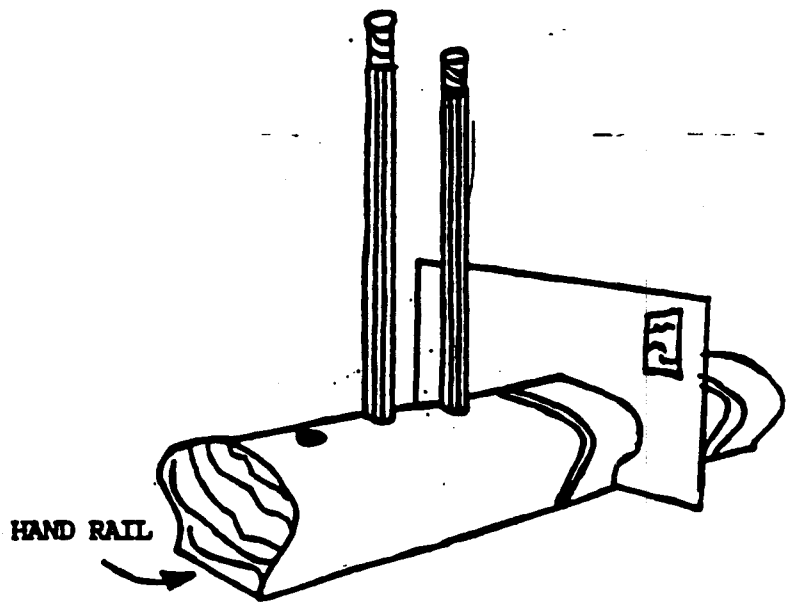

## Fishing Rod Rack

Do you have to take time before each  
fishing trip to untangle your lines and  
hooks? Now you can keep those rods  
separated by hanging them on this rod  
rack. It's just a piece of casing and  
round edge stop that sits on a piece of  
cove. Notches for hanging the rods are  
cut about half way through. Depending  
on how many fishing rods you have,  
you can make the racks as long or short  
as you want. Stain it to warm richness,  
drill holes for screws and hang it in your  
den or office.

