

# POW 1992-93 WOW CUB SCOUT PROGRAM BOOK

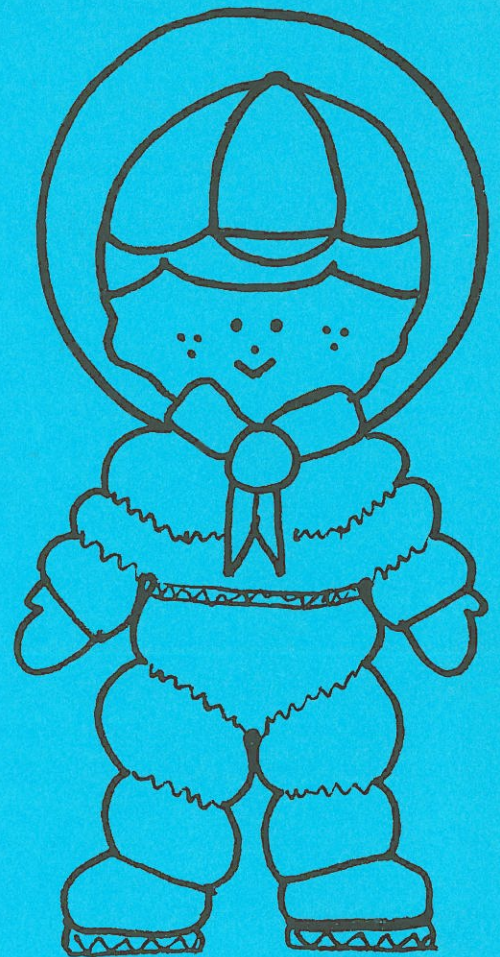

BLAST OFF TO  
THE FUTURE  
DENVER AREA COUNCIL

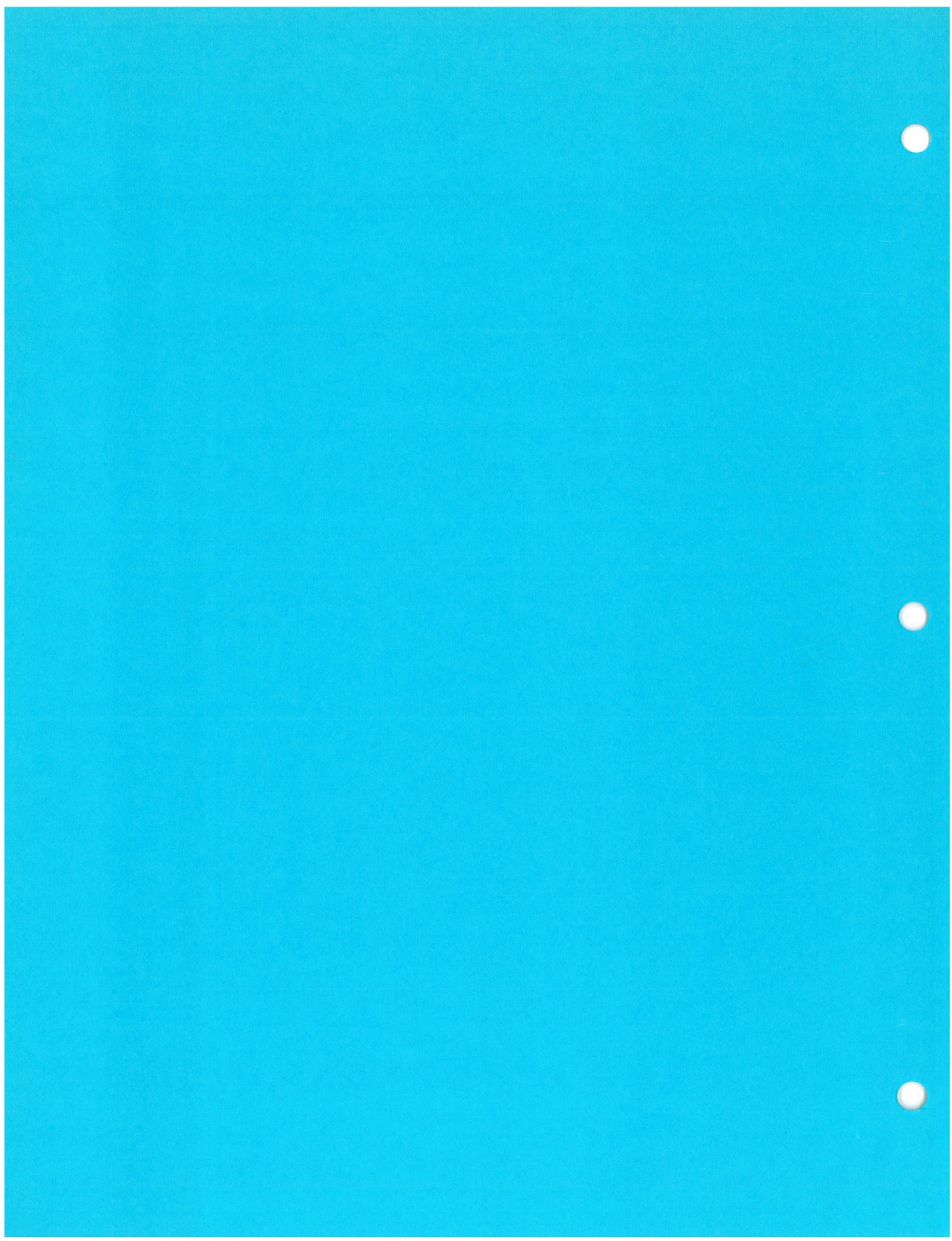

Denver Area Council  
October 24, 1992

Dear Cub Scout Leaders,

This book was designed to be of assistance to you. To help you to better understand and appreciate the Cub Scouting program. Helping to make the program better for the boys has always been my goal.

I have had the opportunity to attend and participate in Pow Wow's for several years, and have benefited from all of them. One of the ways that I can return a small portion of what I have gained is to participate in the background preparation of the program. I took on the project of doing the research and preparation for the 1992-1993 yearly Pow Wow supplement, and though this was to be an act of service, I still learned even more.

I must give credit to many people who have assisted and supported me during this challenging effort. I must first thank my husband, Fred Butler. He is my master computer consultant, and my biggest fan. Next, I need to thank my typist, consultant, and right hand, Virginia Brison. Special thanks must go also to the incredible fingers of Barbara Pace. I have had many artists to help draw the pictures for the dividers; Shaun Olsen, David Durrant, Holly Durrant, Virginia Brison, and Woody Brison. To Richard Faris and to the owners and employees of "Copy Cat" a very heart felt thanks. To these helpers and others (not mentioned) I say, **THANK YOU!** However, most importantly, I must thank God.

From all of us who have labored on this book, we hope you derive benefit from our efforts.

Sincerely,



Marcella W. Butler,

POW WOW Book Chairman

**"Do It Now"**

**I expect to pass through this world but once.  
Any good thing, therefore, that I can do  
or and kindness I can show  
to any fellow human being,  
LET ME DO IT NOW.  
Let me not defer nor neglect it;  
For I shall not pass this way again.**

**(Author Unknown)**





## BOY SCOUTS OF AMERICA

Denver Area Council  
2901 W. 19th Ave.  
Denver, Colorado 80204  
303-455-5522

October 24, 1992

Dear Pow Wow Participant:

It is with great pleasure that I welcome you today to our "Blast Off To The Future" Pow Wow portion of Denver Area Council's new Scouting's Adult Leader Training Seminar (S.A.L.T.S.). Thank you for using a day of your valuable time to improve your knowledge and skills of the Cub Scout Program.

The Cub Scout Leaders' portion of S.A.L.T.S. is designed to provide the mechanics of quality Cub Scouting. You will learn the ingredients in Cub Scouting that will build character and citizenship in our youth.

The youth in Cub Scouting are our astronauts to the future. Our program is their space ship. We adults, parents and leaders, are only the fins of guidance on the space ship each boy steers to his future. When a boy first joins the program, we are very important to the stabilization of the boy. As he grows and matures, we become less necessary. As a boy becomes a young man in Boy Scouts, the adults and leaders he works with become counselors instead of leaders; and the boys lead the program they develop. In years to come, many men will give back to the program by becoming leaders. Thus, Scouting continues into the future.

Please express a very special thank you to the staff who have assembled for you here today. Enjoy your day, learn all you can, share your successes with others, and be a part of the future.

I wish you all the best in Scouting,

Rose Shipley  
1992 Pow Wow Chairman  
S.A.L.T.S.



# We must give credit where credit is due.

There have been so many people who have given of their time and talents and means to make this event a success. The steering committee consisted of the following people;

Rose Shipely Judy Hickman Marcella Butler Nicchi Fatjo Tom Japhet  
Don Shriver Candy Drawe Bill Bennett Dale Utley Edie Mayer Kelly Bowland.

Without the following people, Pow Wow would not be possible. Our special THANKS to all of you for your dedication.

Ron Herro	Ralph Duke	Christa Hill
Neil Steffonich	Jim Cooper	Rich Hill
Linda Cooper	Father Ron Walters	Al Smith
Virginia Brison	Kathy Bridgers	Sue Riecks
Shaun Olsen	Joyce Rangel	Holly Durrant
David Durrant	Larry Hendrix	Woody Brison
A. Fred Butler	Steve Walters`	Carrisa Anderson
Sue Vaughan	Bernice Segesser	Bobby Murtaugh
Kathy Heitman	Kathy Hendrix	Leslie Harclerode
Jerry West	Gary Campbell	Melanie Sparks
John Larsen	Les Huseby	Marge Hoagland
Ron Swanson	Tim Hancock	Bill McMann
Terri Churchill	Tandy Leather Co.	Donna Bunfiglio
Bev Jones	Mike Bonfiglio	Connie Barry
Paula Hancock	Mike Todd	Kathy Lux
Gary Reed		





NOVEMBER



TURKEY DAY



# TURKEY DAY

## GAMES

### Twelve words that begin with the letters "TUR"

1. An oriental head covering. \_\_\_\_\_
2. A mass of matted roots and grass. \_\_\_\_\_
3. A large bird. \_\_\_\_\_
4. Rotated \_\_\_\_\_
5. One who turns. \_\_\_\_\_
6. An edible root. \_\_\_\_\_
7. A small pie or tart. \_\_\_\_\_
8. A colorless oil. \_\_\_\_\_
9. A blue-green color. \_\_\_\_\_

10. A root used as a condiment. \_\_\_\_\_
11. A hard shelled reptile. \_\_\_\_\_
12. A kind of engine. \_\_\_\_\_

### Scrambled Cub Scout Words

1. buc tucos \_\_\_\_\_
2. ned daleer \_\_\_\_\_
3. buc tresam \_\_\_\_\_
4. stream \_\_\_\_\_
5. lub nad ogld \_\_\_\_\_
6. sitks \_\_\_\_\_
7. morenyec \_\_\_\_\_
8. gaf \_\_\_\_\_
9. fronium \_\_\_\_\_
10. recchehefin \_\_\_\_\_
11. ned teingem \_\_\_\_\_
12. cakp gitenem \_\_\_\_\_

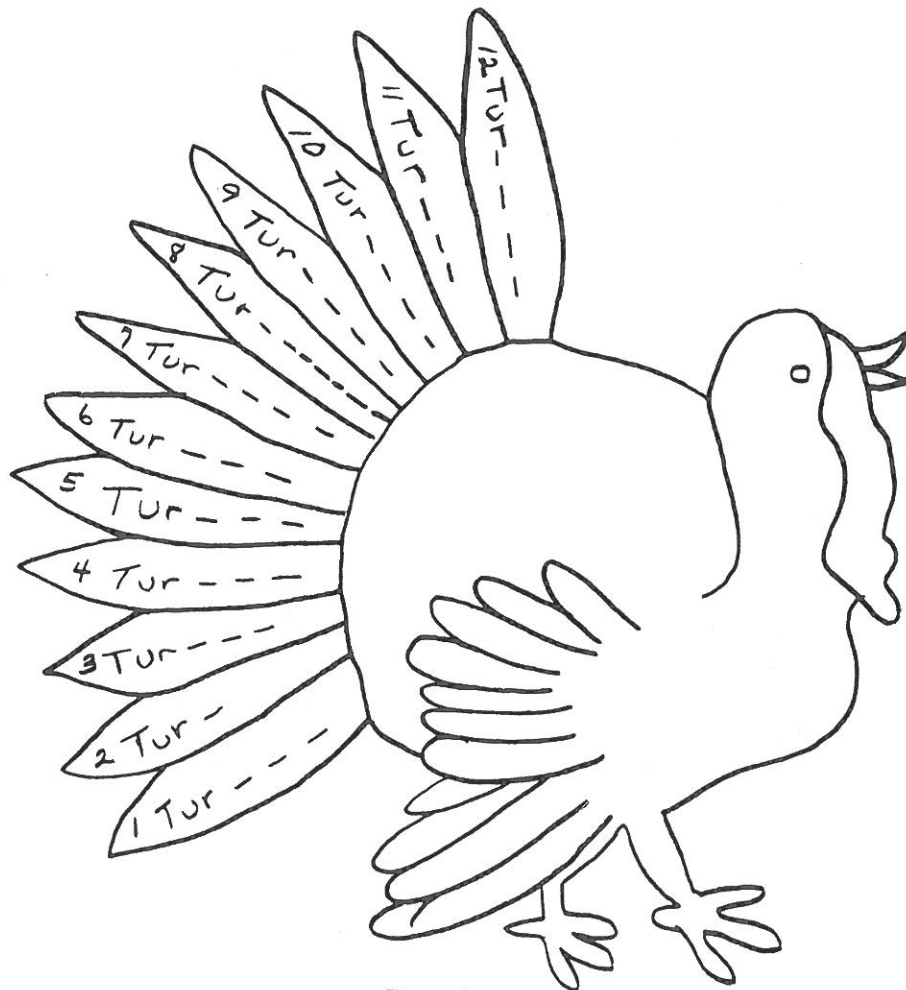

## SKITS

**One More Piece of Pie**

Characters: Mr. and Mrs. Davis and sons  
(the boys are Cub Scouts).

Scene: Thanksgiving Dinner. The Cubs and parents have finished their dinner and are still seated around the table. One piece of pie remains on a plate.

Mr. Davis: Well, Mrs. Davis, you certainly are a good cook.

Mrs. Davis: I can't remember when I've eaten so much and enjoyed it so.

Cub 1 (son): It certainly was delicious.

Cub 2 (son): I couldn't eat another bite if you paid me.

Mr. Davis: Oh, come now! You know there's plenty left in the kitchen. Let's have a little more.

All: No. No, not another bite. You know we couldn't.

Mrs. Davis: Just look at that one little lonesome piece of pie. Surely someone will finish the pie.

Cub 3: Not me. How about \_\_\_\_\_  
(Cub 2)?

Cub 2: Not me. I've eaten more than anyone else--well, anyone except (Jeff). Cub 1.

Mr. Davis: Yes, for once I think Jeff has had his fill. I bet he couldn't hold another crumb.

Mrs. Davis: Oh dear, there's just one little piece of pie left. I wish someone would eat it.

(Jeff): Cub 1: Nobody asked me. I'd like that piece of pie.

Mrs. Davis: (Jeff), If you eat one more thing you'll explode.

(Jeff): I'll take that chance. Please pass the pie.

(Jeff): Eats the pie with back to audience and then three prop men off to the side break blown-up paper bags.

All: JEFF!!!

**Tur-Key Or Not Tur-Key**

## CHARACTERS:

5 - country boys  
1 - turkey.

COSTUMES: Turkey is a boy dressed with construction paper feathers, red crepe paper wattle, yellow crepe paper legs and a yellow paper beak. Other boys wear jeans and plaid shirts.

## Scene 1

SETTING: Country boy has raised the Thanksgiving Turkey. It has come time for the bird to be readied for dinner. The boy and the turkey are sitting on the ground by a tree stump. They look sad. The boy holds a blue ribbon.

1<sup>ST</sup> BOY: (Walks across stage behind boy and turkey.) Well, it's almost time. (He sits down with them, looking sad.)

2ND BOY: (Walks across after 1<sup>st</sup> boy and sits down.) Boy, a drumstick sure will taste good. I can hardly wait! (He looks at the boys and turkey.) Oooops, sorry! (He pets bird, sits down, and looks sad.)

3<sup>RD</sup> BOY: (Walks over to others.) We're really going to have to get (whispers and points) HIM ready soon. (See that everyone is sad--sits down, looking sad with the others.)

4<sup>TH</sup> BOY: (Comes in carrying an ax. the other boys begin to cry and pet the bird.) It's time!

(As curtain closes on scene 1, the turkey is leaning over the tree stump with 4<sup>th</sup> boy holding the cardboard ax over his neck.)

### Scene 2

SETTING: All boys and turkey are seated at table. All have heads bowed.

5<sup>TH</sup> BOY: Thank you, Lord, for this corn we are having for dinner. (The turkey looks at the audience and gives an exaggerated wink.)

### SONGS

#### Turkey Song

(Tune: Bring Back My Bonnie)

My turkey went walking one morning,  
The November weather to see.  
A man with a hatchet approached her.  
Oh, bring back my turkey to me.

Chorus:  
Bring back, bring back  
Oh, bring back my turkey to me, to me.  
Bring back, bring back  
Oh, bring back my turkey to me.

I went down the sidewalk a shoppn'  
The sights in shop windows to see,  
And everywhere hung great fat gobblers,  
Oh, bring back my turkey to me.

(Chorus)

I went out to dinner and ordered  
The best things they had I could see.  
They brought it all roasted and sizzling,  
They brought back my turkey to me.

Brought back, brought back,  
They brought back my turkey to me, to me.  
Brought back, brought back,  
They brought back my turkey to me.

#### Turkey's Plight

(Tune: Deep in the Heart of Texas)

They turkey's plight  
Is just a fright,  
Back in the farmer's barnyard!  
Our sad-eyed croon,  
Would make you swoon,  
Back in the farmer's barnyard!  
The big fat hens,  
Were once our friends,  
Back in the farmer's barnyard!  
We skinny birds,  
Now sing sad words,  
Back in the farmer's barnyard!  
Some Thanksgiving Day,  
We'll fly away,  
And leave the farmer's barnyard!  
We'll find a table,  
With a Thanksgiving label,  
Far from the farmer's barnyard!  
We'll fly off hobble,  
We will gobble,  
Far from the farmer's barnyard!  
We'll be a feast,  
To say the least,  
Far from the farmer's barnyard!



# DECEMBER

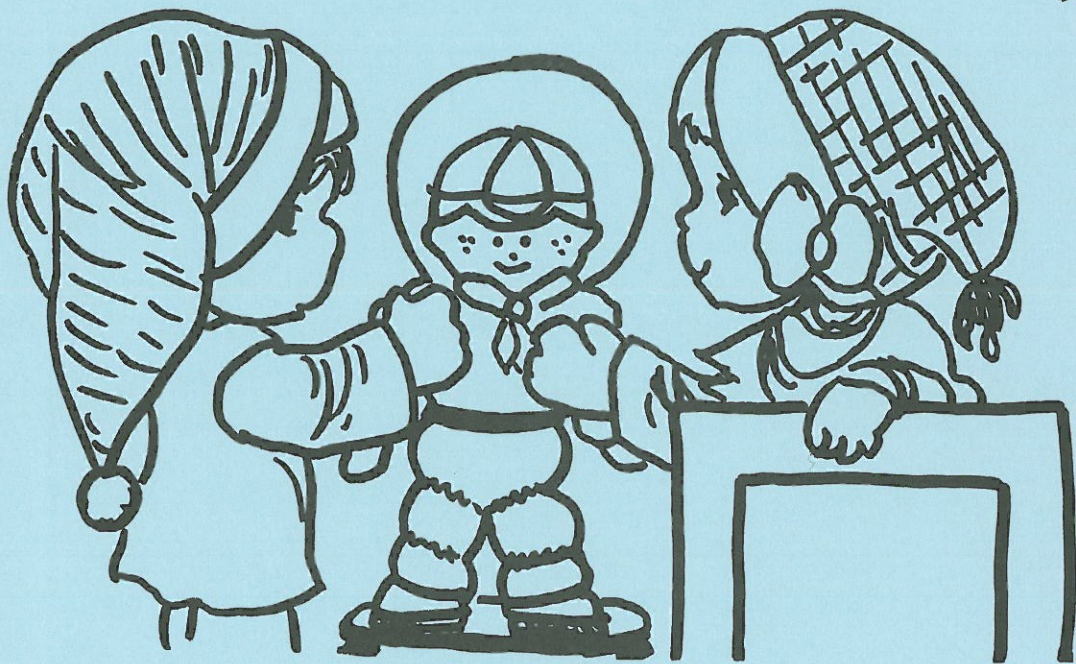

# HELPING OTHERS





## HELPING OTHERS

### GAMES

#### Shopping Bag Toss

Materials Needed:

- 1 - shopping bag
- 6 - balls of yarn

Use two boys. Hold shopping bag by handles in teeth. Place yarn balls in bag. By swinging bag over their heads, drop balls out of bag. Do not use hands.



#### Balloon Bounce

Materials Needed:

- 1 - tall box
- balloons

Divide the boys into pairs and give each pair a blown-up balloon. The object is for each pair to get their balloon into the box from a starting point by only using the tops of their heads. They may maneuver around the box to get the balloon in. **NO HANDS.**

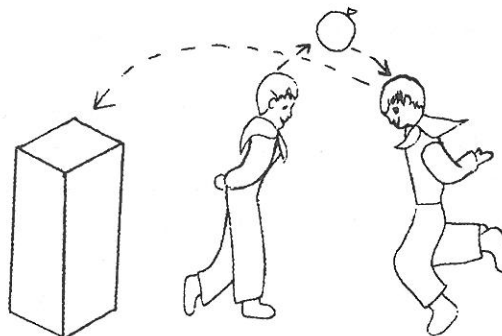

### CRAFTS

#### Snowstorm Jar

Materials Needed:

- Jar with screw-on lid
- Waterproof cement
- Small figure of your choice
- Moth flakes, mica snow or crushed moth balls

With glue (waterproof cement), glue a small figure inside bottom of jar or inside lid. Let dry thoroughly. Fill jar with water and add a teaspoon or two of moth flakes, mica snow, or crushed moth balls. Apply cement liberally around rim of jar. Replace lid and let dry thoroughly. Jars made a few weeks in advance allow the snow to settle rather than float. Use as a gift or just a fun craft.

#### Scout Sign Slide

Materials Needed:

- 2" x 2" square of 1/8" plywood, or balsa
- 2 - popsicle sticks
- slide ring

Tools Needed:

- sandpaper
- file
- knife
- glue gun
- light and dark stain

dark, permanent, fine-line marker

Cut the popsicle sticks into: two pieces 1-7/8" long, two pieces 1-1/2" long, and one piece 1-1/8" long. Round the edges to the same radius as in the original uncut ends.

Sand wood pieces smooth and stain the 2"x2" square dark and the popsicle sticks light.

Glue popsicle sticks to form a stylized Cub Scout sign. Glue slide ring to the back.

Add F, H, and G to the lower ringers, as shown, to represent the hidden values of Follow, Help, and Give.

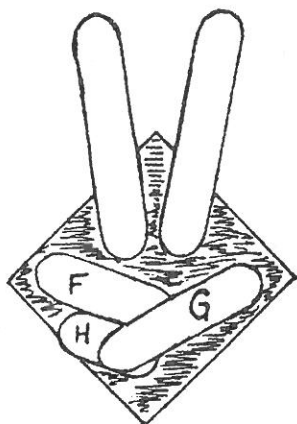

## SONGS

### I Love That Word Hello

(Tune: "Auld Lang Syne")

I love to hear that word "Hello,"  
Wherever I may go.  
It's full of friendship and good cheer,  
And warms the heart up so.  
Hello, hello, hello, hello,  
Hello, hello, hello;  
Where ere we meet,  
Like friends let's greet  
Each other with "Hello."

### Cub Scout Marching Song

(Tune: "This Old Man")

This young Cub, number one,  
He sure likes to get things done.

Chorus:  
With a knick knack paddy wack,  
Give a Cub a chore;  
This he'll do and ask for more.

This young Cub, # two,  
He will do odd jobs for you.  
(Chorus)

This young Cub, # three,  
Full of humor, full of glee.  
(Chorus)

This young cub, # four,  
Follows rules and knows the score.  
(Chorus)

This young Cub, # five,  
He has courage, he has drive.  
(Chorus)

This young Cub, # six,  
He'll make things with ropes and sticks.  
(Chorus)

This young Cub, # seven,  
Becomes a Boy Scout at eleven.  
(Chorus)

This young Cub, # eight,  
Gives goodwill that sure does rate.  
(Chorus)

This young Cub, # nine,  
He's so pleasant all the time.  
(Chorus)

This young Cub, # ten.  
Sings the chorus once again.  
(Chorus)

**Cub Scout Prayer**  
(Tune: "Tannenbaum")

Lord, in this evening hour I pray  
For strength to do my best each day.  
Draw near to me that I may see  
The kind of Cub that I should be.

In serving others, let me see  
That I am serving Thee, daily.  
Bless me, oh Lord, in Thy great love,  
That I may be a better Cub.

**Twelve Days Of Christmas**

On the first day of Christmas, A Cub Scout  
said to me:

- (1) A den meeting is the place to be!
- (2) Let's sing a pledge.
- (3) Let's tie a knot.
- (4) Let's go a-hiking.
- (5) LET'S SING A SONG!
- (6) Let's saw a board.
- (7) Let's feed some birds.
- (8) Let's do a skit.
- (9) Let's be polite.
- (10) Let's show respect.
- (11) Let's be good friends.
- (12) Let's THANK OUR LEADERS!

**Cub Scouting We Will Go**  
(Tune: "Jingle Bells")

Cub Scouting we will go  
To a den where we can play  
Sunshine, rain, or snow,  
Happy on our way.

As buddies we will greet  
Faces gleaming bright;  
What fun it is when we can meet  
And do the things we like!

Chorus:

Cub Scout days!  
Cub Scout days!  
Dear old Cub Scout days!  
O what fun for everyone  
In a den where we can play.  
(Repeat)

**SKITS**

**To Recycle Or Not**

**CHARACTERS:**

Mom  
Dad  
Cub Scout  
2 other children

**SCENE:** Cub Scout's home.

**TIME:** Night before trash pickup day.

**MOM:** Dear, don't forget tonight's trash night.

**DAD:** Oh, yeah. Come on kids, let's get the trash out. (Kids come in, each dragging large, full trash bags.)

**CUB SCOUT:** Gee Dad, this job gets harder every week.

**CHILD 1:** Yeah, I thought the job would get easier as I got bigger. Instead the trash is growing faster than I am.

**CHILD 2:** I can hardly pull mine, much less carry it.

**DAD:** What are you complaining about? I've three more bags I've got to take out. I don't understand it... My folks had twice as many kids and half as much trash when I was a kid.

**MOM:** I guess that's what they mean when they say we're living in a throw-away society. Everything comes packaged and the packaging has to be thrown away. Such a waste!

**CUB SCOUT:** You know, we wouldn't have to throw away EVERYTHING--the Boy Scouts at our school collect aluminum

cans and other aluminum things to be recycled.

CHILD 1: What's that mean--give it a ride on a bike?

CUB SCOUT: No it means they send it to a company that makes new aluminum things out of old aluminum that would be thrown out.

CHILD 2: Hey, yeah--I think they take old newspapers, too!

MOM: Right. I even heard that some places take tin cans. We've got plenty of those.

DAD: You know, I seem to remember my folks saving tin and newspapers and lots of other things during the second World War. It all went for the war effort. It was considered a patriotic thing to do.

CUB SCOUT: It still is, Dad; but now it's a war against waste.

MOM: And think of how much of our natural resources would be saved if everyone got into the act.

CHILD 1: Let's do it, Mom. I bet we could think of lots of things that could be uh, uh...

CUB SCOUT: Recycled.

DAD: You know, a fellow down at work, when he changes the oil in his car, takes the old oil to a recycling center. Heck, I never know how to get rid of the stuff anyway.

MOM: OK, we'll do it. But remember, it won't mean we'll have less trash, it will just mean we'll be redistributing it.

CHILD 2: That's OK, Mom. At least we'll feel good about it. We'll be patriotic!

DAD: OK everyone. What's gonna be the watchword around here?

EVERYONE: R E C Y C L E!!!

CUB SCOUT: (To audience.) By recycling, we can help other people and ourselves. And we hope you join us, too!



### Buc Tuocs

DR. CURE ALL: Thank you, my friends. Boys, have you been feeling sluggish lately? Do you have that gray feeling? I have the answer to your woes; Buc Tuocs! Here are some people that have tried it and are wild about it. Let's hear from them.

FIRST BOY: When I reached eight, I needed something. I was out of touch. I tried Buc Tuocs and got the lift I needed.

SECOND BOY: I couldn't adjust. My social life was falling apart. Buc Tuocs was the answer.

THIRD BOY: I was afraid of growing old. Was life passing me by? Buc Tuocs gave my life purpose.

FOURTH BOY: My kindergarten friends had gone in different directions. Buc Tuocs helps me find new acquaintances. (Use more testimonials if you have more boys.)

DR. CURE ALL: Thank you boys for your unsolicited testimonials. Remember folks, try Buc Tuosc -- it's Cub Scout spelled backward!!!!

### The Den Mother's Bouquet

CHARACTERS:

Six Cubs in summer uniform or Cub Scout T-shirts.

SCENE: A nature walk with Den 3.

PROPS: Cub-fashioned bouquet, with strands of ivy.

1<sup>ST</sup> CUB: Gee, fellas, I don't think Mrs. Brown's having a very good time.

2<sup>ND</sup> CUB: Well, you didn't help things much, giving her that garter snake.

3<sup>RD</sup> CUB: I was just trying to help her collect stuff for our nature display at the pack meeting.

4<sup>TH</sup> CUB: Yeah ... and you hears what she said! "Nothin' ever again that moves by itself!"

3<sup>RD</sup> CUB So ... now I know better!

5<sup>TH</sup> CUB: Don't worry about a thing, you guys. I'm gonna fix everything.

6<sup>TH</sup> CUB: Yeah? How?

5<sup>TH</sup> CUB: Well, you know how nutty women are about flowers? So I picked her this neat bunch of flowers...(he holds up bouquet, with trailing strands of ivy)... See?

6<sup>TH</sup> CUB: Oh, no ...(wails) We'll never get to go on another hike!

5<sup>TH</sup> CUB: How come?

6<sup>TH</sup> CUB: Cause ..... that's poison ivy!

(All five cubs say "OH NO" in loud, disgusted voices and run off stage, leaving 5<sup>TH</sup> CUB standing with bouquet. He drops it, starts to scratch, and also runs off stage.)

### A Great Christmas

(Divide group into 8 parts as follows. All parts stand to do their routine.)

SANTA CLAUSE: Hold belly and laugh "Ho, Ho, Ho."

SNOW: Sprinkle with fingers, saying, "Flake, Flake, Flake."

PRESENTS: Spread arms and shout, "A new bike."

GREETING CARDS: Throw up hands and say, "Hang 'em on the wall."

MOM AND DAD: Scold with finger, saying, "You'd better be good."

HOLIDAY DINNER: Shrug shoulders, hold up hands, saying, "Where's the beef?"

ANGELS: Do "Twilight Zone" theme while flapping arms.

DECORATIONS: Sing "Deck the Halls with Boughs of Holly!"

CHRISTMAS: All sounds and parts at the same time.

My favorite holiday is CHRISTMAS. I enjoy sending GREETING CARDS, I enjoy a big HOLIDAY DINNER, I enjoy the SNOW, but most of all, I enjoy SANTA CLAUS bringing me lots of PRESENTS.

The house is filled with DECORATIONS. My favorite is the silver ANGELS. I help MOM AND DAD open the GREETING CARDS, fix the HOLIDAY DINNER, shovel the SNOW, wrap the PRESENTS, put up the DECORATIONS, and polish the silver ANGELS. After we're finished, I leave out milk and cookies for SANTA CLAUS while MOM AND DAD clean up. I can hardly wait until CHRISTMAS morning.

I race to the tree. I see that SANTA CLAUS has left me lots of PRESENTS, with little GREETING CARDS on them. He's put some new DECORATIONS on the tree, including some new silver ANGELS, and he has sprinkled the branches with artificial SNOW. Of course, he has left some lovely grownup gifts for MOM AND DAD.

So we sit down to eat our HOLIDAY DINNER. I turn on the radio and Frank Sinatra is singing "Hark the Herald ANGELS Sing." MOM AND DAD and I say grace and eat our HOLIDAY DINNER while the DECORATIONS twinkle all over the house. After dinner we look at the

GREETING CARDS one more time, and then go out for an afternoon stroll in the falling SNOW.

I tell you, that SANTA CLAUSE is quite a guy! He sure knows how to turn out a great CHRISTMAS.

JANUARY



PIRATE  
WATERS





## PIRATE WATERS

### GAMES

#### Soap Boat Regatta

Have the boys carve a boat of their design in a small bar of Ivory soap. Potato peelers, melon ballers, spoons, and knives can be used to carve with. "Sand" the finished carving with a piece of Scotch Brite scouring pad.

**The boats must then be covered with a layer of nail polish or spray varnish.**

The raceway consists of two 10 foot lengths of rain trough filled with water set on saw horses or a table.

The boys propel the boats by blowing the boat along through a straw while their hands are behind their backs.

Two cubs race at a time, and each heat is timed by a stopwatch. The best times win first, second, and third.

#### Rock Range

Materials Needed:

- 4 - plastic pirate ships (plastic jugs with lids make good pirate ships)
- Twine

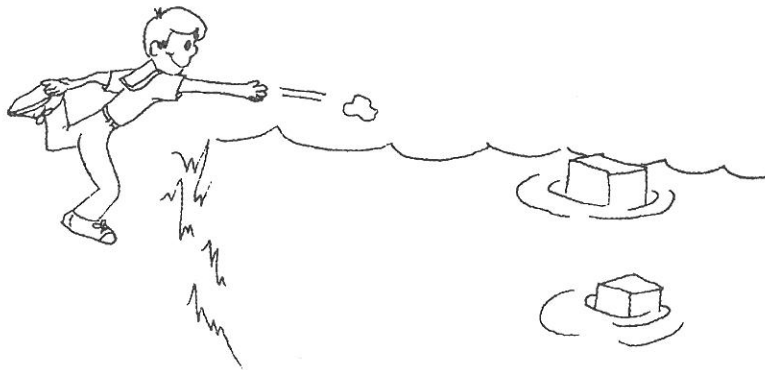

Lake or pool  
Rocks

Preparation:

Tie the twine to handle of milk jug and then to a rock as an anchor. Pirate ships are placed at various distances in the lake. Be sure to place them far away from any boat docks or designated swimming areas.

Event:

Participants take turns throwing rocks at the pirate ships. Following ideas are different ways to compete:

- (1) Lob the rocks to land on top of the pirate ships.
- (2) Most hits in a row wins.
- (3) Skip the rock on the water prior to it hitting the pirate ship.
- (4) Skip a rock on the water, over the pirate ship without touching it, and another skip before its momentum stops.

#### Fishing Game

You need a soda straw for each player and 15 or more paper fish.

Place the fish on the floor. Fish are caught by suction. See who can catch the most fish. Do as a relay or individually.

### Raft Race

Teams line up in relay formation. The first Cub Scout in each line is the skipper and he stands with his feet on separate pads of newspaper. The second Cub Scout is the passenger and he stands on the same pads with the skipper. On a signal from the leader, the skipper bends over and takes hold of the pads, one in each hand. By shifting their weight and sliding the paper forward, the two boys maneuver themselves to the goal line without stepping off the paper. On reaching the goal, the passenger picks up the pads of paper, runs back to his team, and brings the next boy across the river. The first team to bring all of its passengers across the river wins.

### Octopus Race

Divide the den into two teams of three to four boys each. The teams form with backs together, elbows linked. On signal, they race to a turning point and back to the start. First team through wins.

### Deep-Sea Fishing Contest

#### Materials Needed:

- A bucket or large pan of water
- Several wooden clothespins (w/o springs)
- 2 - homemade fishing poles (at least three feet long)
- 2 - pieces of string
- 2 - nails or bolts.
- wax crayon

With wax crayon, write a number on one side of each clothespin. Tie the strings to the poles and tie a nail or bolt onto the other end of the line.

Put the clothespins in the water with the numbered side down. Cub Scouts then go "fishing," trying to maneuver the nail or bolt so that the string goes between the prongs of the clothespins and catch the "fish" by pulling up. Scoring may be on the basis of the most "fish" caught or highest point total.

## CRAFTS

### Gator Sculpture

#### Materials Needed:

- A few egg cartons
- 3 - rectangular-shaped cartons
- large pieces of stiff cardboard
- colored tissue paper
- glue or staples
- paint
- scissors

(Examples on top of next page.)

Draw an outline of a large alligator, about three feet long from its neck to its tail, on heavy cardboard. Omit the head for now. Cut out. Draw and cut out two pairs of legs from another piece of cardboard. (Rear legs longer and fatter than the front ones.) Glue or staple legs onto body. Glue or staple body over rectangular carton to shape the belly and to lift sculpture off the ground. Bend legs to touch the ground.

Glue several egg cartons to the back of the alligator, cutting and tapering to fit the shape of the body. Be sure some of the egg cups extend onto the tail section.

To construct the head, staple or glue two same-sized rectangular cartons together at one end, giving the appearance of gaping jaws. Taper the carton and notch their edges to resemble snapping jaws with mean, jagged

teeth. Line the bottom and roof of the mouth with crumpled pink tissue paper. Add halves of eggshells for bulging eyes. Join head securely to the body by stapling or gluing these parts together.

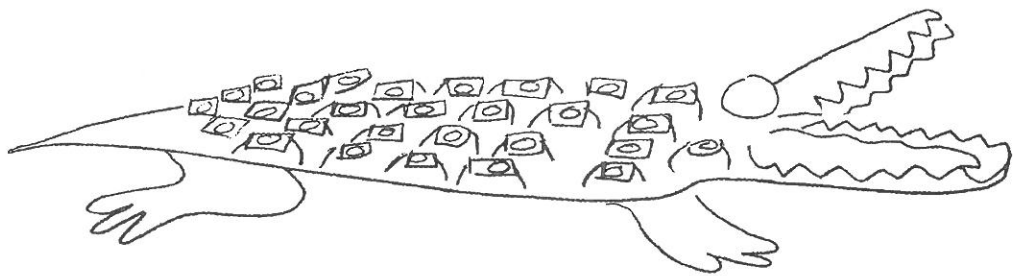
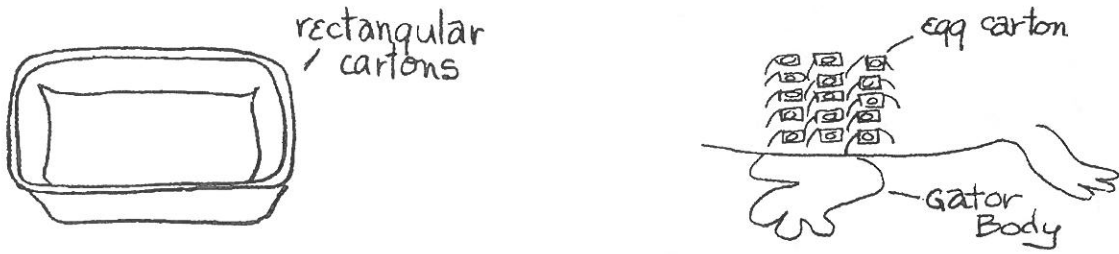

### How To Make A Slapstick Treasure Chest

**Materials Needed:**

- 30 - sticks
- 4 - small wood beads
- 3 - yards Dura Plex Plastic Lace
- 4 - cork pieces

Begin with Bottom. Lay 5 sticks flat and parallel so they touch. Now take the two larger cork pieces and spread cement on the narrowest edges. Set them on top of the sticks, one at each end, running crosswise to the sticks so that each stick is cemented. There should be an overlap of about 1/16" on each side of the cork piece.

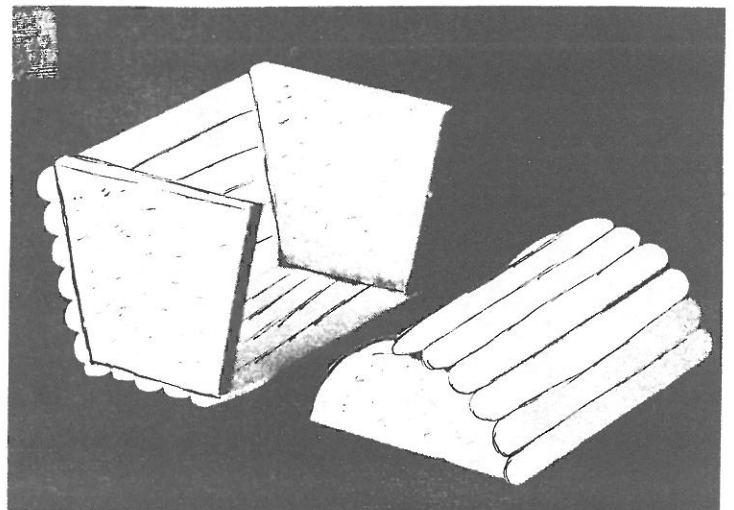

Cement Sides. Cement in six sticks on each side and the bottom half of your chest is complete. Repeat this procedure using the 2 cork half-discs to complete the top half of

the chest. Place the two halves together and cement on the plastic binding as shown. This will act as the hinges and also be decorative.

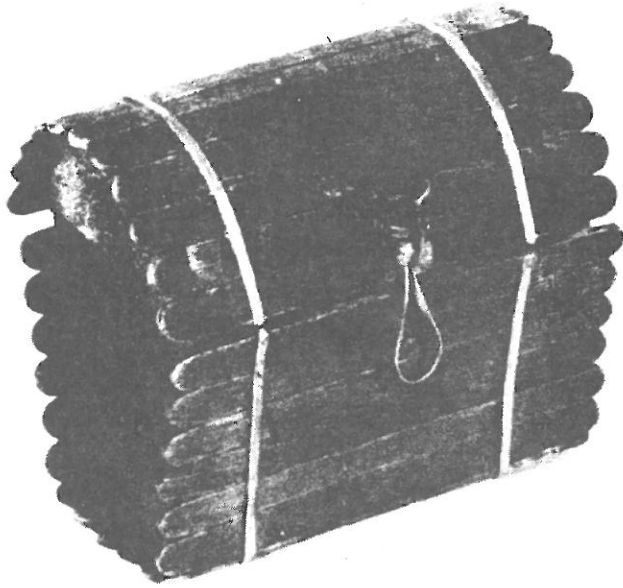

Cement on the small beads. The small beads are to be cemented on each corner of the bottom of the chest to serve as "feet." Your project is now complete. However, you may wish to stain the chest with wood stain, or paint it in your favorite color, or decorate it with gold thread, etc.

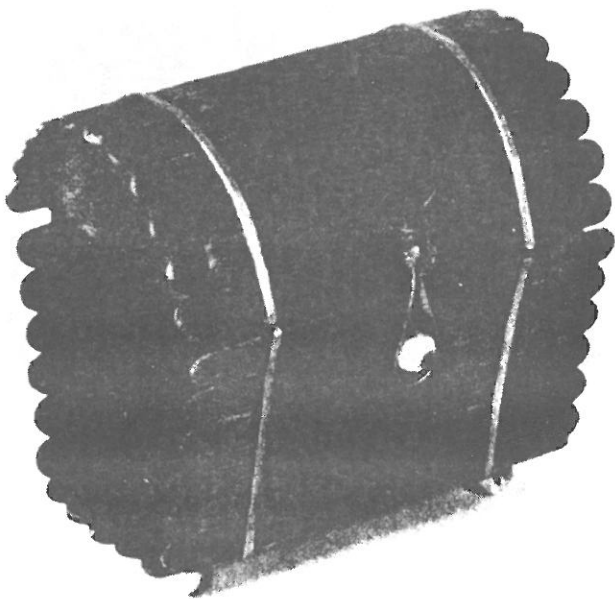

## SONGS

### There's A Hole In The Bottom Of The Sea

1. There's a hole in the bottom of the sea,  
There's a hole in the bottom of the sea,  
There's a hole, there's a hole,  
There's a hole in the bottom of the sea.
2. There's a log in the hole, in the bottom of the sea...
3. There's a bump on the log, in the hold, in the bottom of the sea....
4. There's a frog on the bump, on the log, in the hole in the bottom of the sea....
5. There's a wart on the frog, on the bump, on the log, in the hole, in the bottom of the sea....
6. There's a hair on the wart, on the frog, on the bump, on the log, in the hole, in the bottom of the sea.
7. There's a flea on the hair, on the wart, on the frog, on the bump, on the log, in the hole, in the bottom of the sea....
8. There's a germ on the flea, on the hair, on the wart, on the frog, on the bump, on the log, in the hole, in the bottom of the sea....
9. There's a (grunt!) on the germ, on the flea, on the hair, on the wart, on the frog, on the bump, on the log, in the hole, in the bottom of the sea....

Finger and Arm Movements: 1) Point finger downward, 2) hold forearm up, 3) slam fist down on the word "bump," 4) hold fist up then slam down on word "bump," 5) make small circle in front of you with thumb and forefinger, 6) point to hair, 7) hold pinkie up, 8) hold forefinger just over thumb without touching, 9) grunt or squeak. Don't forget to repeat circle-with-forefinger motion at end of each verse, pointing downward.

**The Whale**

A long time ago there lived a whale.  
They fed her oysters by the pail.  
By bathtub, by teacup, and by schooner.

Her name was Sarah and when she smiled,  
She just showed teeth for miles and miles.  
And tonsils and spareribs, and things too  
fierce to mention.

Now, what would you do with a whale like  
that?

What would you do if she sat on your hat?  
Or your mother, or your toothbrush, or  
anything else that's useless.

**The Deck Swabbers**

Two deck swabbers swabbing a deck watch  
their Captain walk by then just stand around.  
One swabbee turns to the other.

1<sup>ST</sup> SWABBEE: "Why do we do all the  
work, while the Captain gets paid more?"

2<sup>ND</sup> SWABBEE: "I don't know. Why don't  
you go ask?"

1<sup>ST</sup> SWABBEE: (To Captain) "Why do we  
do all the work, while you stand and watch  
and get paid more on top of it?"

CAPTAIN: "Cause I'm smarter than you  
are."

1<sup>ST</sup> SWABBEE: (angrily) "What do you  
mean?"

CAPTAIN: "I'll show you." (Captain puts his  
hand in front of a mast.) "OK, hit my hand as  
hard as you can."

1<sup>ST</sup> Swabbee swings and the Captain pulls  
his hand away. The swabbee hits the mast  
instead.

1<sup>ST</sup> SWABBEE: "Ow, ow, ow, ow!"

CAPTAIN: "Now, go back to work."

1<sup>ST</sup> swabbee goes back to the deck.

2<sup>ND</sup> SWABBEE: "Well, what was the  
answer?"

1<sup>ST</sup> SWABBEE: "Because he's smarter  
than we are."

2<sup>ND</sup> SWABBEE: (angrily) "What do you  
mean?"

1<sup>ST</sup> SWABBEE: "I'll show you. Pick up  
that mop." (The 1<sup>st</sup> swabbee puts his hand in  
front of his face.) "OK, hit my hand as hard  
as you can."

**It Takes Real Men**

SCENE: A group of Pirates enter, sit at a  
table, and look dejected.

HEAD PIRATE: I'm bored! We haven't  
done anything exciting in days.

PIRATE W/PATCH: Aye! Aye!

PIRATE #3: What we need is a treasure  
hunt! Let's go to Treasure Island.

PIRATE #4: No, that's been done.

PIRATE W/PATCH: Aye, that's true.

HEAD PIRATE: Well, how about exploring  
a new land, far, far away.

PIRATE W/PATCH: We'll see things no one's ever seen before!

PIRATE #3: It's agreed then, off we go to sail to a new land.

ALL: "To the ship!" "Hoist the Jolly Roger!" "Anchors away!"

(Joyously, all exit together.)

### Act 2

SCENE: A sign is put before the audience to indicate that time has passed. "Deserted Island, 2 years later." Empty stage. Band of Pirates enter, with ragged clothes and a much more somber spirit.

PIRATE W/PATCH: Boy, what an eyesore!

HEAD PIRATE: This place is absolutely bare. There's nothing to eat, nothing to drink, no treasure to find.

PIRATE #4: Are we there yet?

PIRATE #3: Stop! I hear voices. Hide, you guys. Hide!

(All Pirates try to hide behind one another. Finally they're all behind the Pirate w/Patch, with the Head Pirate covering his one good eye.)

PIRATE W/PATCH: They sure won't see us in this dark.

(Enter 2 or 3 Cub Scouts. At first, they don't see the Pirates. Then they all jump in unison, startled when the Pirates are noticed. The Cub Scouts confer quickly. Then they approach the Pirates.)

CUB SCOUT 1: Ahem...

(Pirates shake and cower closer together.)

CUT SCOUT 2: Excuse us, please.

(Pirates cautiously peer around one another. Eventually they push the Head Pirate to the front.)

HEAD PIRATE: Yes... Yes?

CUT SCOUT 1: Can we help you? You seem to be in trouble.

PIRATES: (all at once) "Aye, we're lost." "We're hungry." "We're thirsty."

CUB SCOUT 2: Why don't you come with us to our campfire. We're having supper soon.

PIRATES: (all at once) "Sounds good." "Why not?" "Let's go!"

HEAD PIRATE: We accept your invitation. By the way, what are we eating?

CUB SCOUTS: (together) Cub Scout food. Peanut butter and sardine sandwiches; soggy, crushed potato chips; melted chocolate bars; and warm Koolaid. (obviously pleased with menu)

(Pirates look quickly at each other and gesture as if in pain.)

HEAD PIRATE: To the ship! (all run away)

(Cub Scouts remain, watching Pirates depart.)

CUB 1: Well, that's another bunch of weirdoes we don't have to mess with.

CUB 2: Yeah, now let's go back to our den, get our food, and tell our leader what we saw.

CUB 1: Naw, she wouldn't believe us.

We must be the happiest lot.

CUB 2: Yeah, you're right. (pointing) To food!

Oh Lord its hard to be humble, but we're doing the best that we can.

(Both run off stage.)

Retire Colors.

## PACK CEREMONIES

### Pirate Waters

(The Cub master with a patch over an eye.)  
"Good evening mates. Me and my crew have scoured the 7 Seas. We have brought back great treasures to be divided up among me faithful crew. (Two Scouts carry in treasure chest loaded with the awards for the night.) The two Cubs try to peek inside, the Cub master closes the lid.) "Shove off mates, plenty of time for that later, but first we must pay honor to our homeland. (Assigned Den does the flat ceremony.)

Advancement: The awards are pinned to pictures of skull-&-crossbones. Pass out the booty to the Cubs and parents being honored. Keep all the Scouts up front.  
"Congratulations mates on a job well done, now you must take the Pirate's Pledge promising to work hard towards your next achievement.

Do as I do and repeat after me:

"Thumbs up--Elbows back, knees together, toes in, chest out, buns back, chin up, tongue out. I promise to work hard, diligently, and to help my fellow mates."

Closing: Have everyone stand & sing:

(Tune: "Oh, Lord It's Hard to be Humble")

Oh Lord its hard to be humble, when you're pirates in every way.

We can't wait to look in the mirror.

We get prettier every day.

To know us is to love us.





# FEBRUARY



# OLD GLORY



## OLD GLORY

### THE ORIGIN OF OUR FLAG

Most people in America think that the stars and stripes were ordered by General George Washington; that Betsy Ross sewed the first flag; and that the revolutionary forces used this flag from the day the Declaration of Independence was signed.

The story of the stars and stripes is the story of the nation itself; the evolution of our free institutions and the nation's development into a great land.

Early in the days of the Republic, when the 13 original states were still colonies, the banners borne by the Revolutionary forces were as varied as the races that made up the liberty-loving colonists. The local flags and colonial devices displayed in battle on land and sea during the first months of the American revolution carried the varied grievances that the individual states had against their mother Country, England.

After July 4, 1776, the people of the colonies felt the need of a national flag to symbolize their new spirit of unity and independence. Congress, on July 14, 1777, Adopted the following resolution: *Resolved that the flag of the thirteen United States be thirteen stripes, alternate red and white, that the union be thirteen stars, white on a blue field.* The significance of the colors was defined as: **White** signifies Purity and Innocence; **Red**, Hardiness and valor; **Blue**, Vigilance, Perseverance and justice.

Betsy Ross, a flag maker of Philadelphia, is credited by some historians with having made the first flag and with having suggested that the stars be five-pointed. The home of Betsy Ross at 230 Arch Street, Philadelphia, is a national shrine and the flag flies on a



staff from her third floor window. Thousands of people of all nations visit this house, which is known as the Birthplace of Old Glory.

It is true that Betsy Ross was a flag maker. There is in the Navy archives an order to Elizabeth Ross 'for making ships colors' for 14 pounds, 12 shillings and 2 pence, paid to her exactly two weeks before the flag resolution of June 14, 1777. None of the authentic records of history substantiate the story that Betsy Ross was appointed by congress to design a flag. Neither the annals of the Continental Congress nor the personal writings of anyone, including George Washington, shed light on the question of when, where, or by whom the first American flag was made.

But regardless of whom was responsible for making the first flag, the stars and stripes, born in the midst of battle, proudly announce to the world the birth of a new nation. However obscure its origin, the flag was soon hailed universally as the symbol of the land of the free.

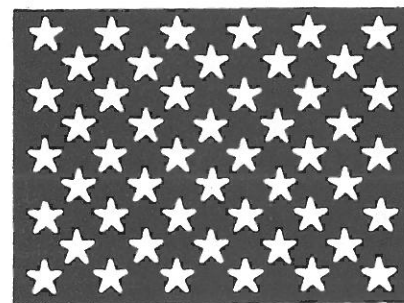
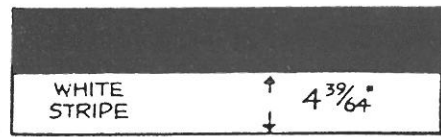
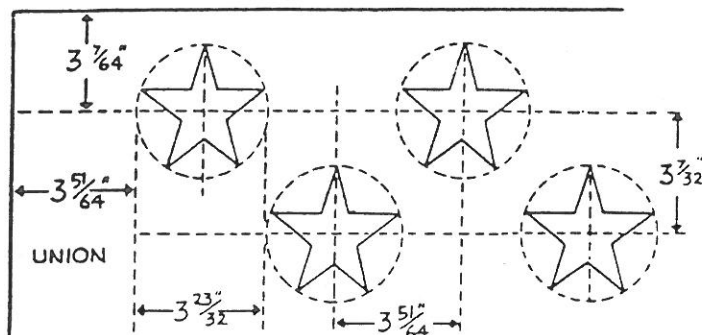
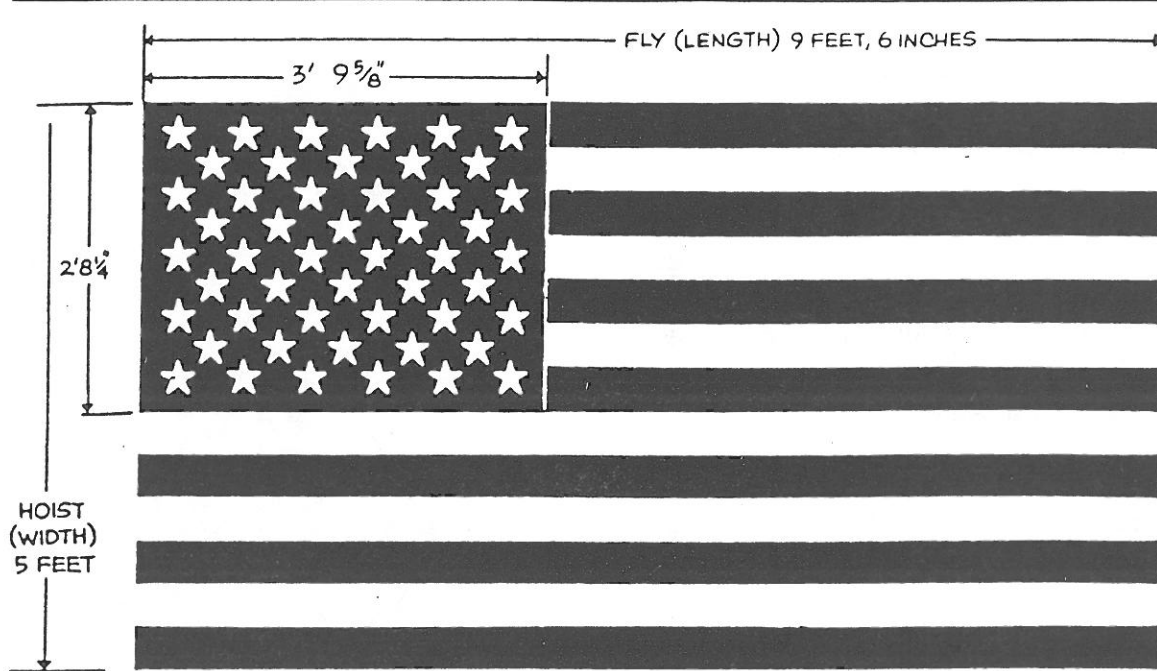

**OUR FLAG TODAY**

Although two more stars have been added to the blue union since 1912, the proportional dimensions of the flag remain the same.

The stars were added for the two new states admitted \*(Alaska-1959 and Hawaii-1959) Making the 27<sup>th</sup> official change in the flag since its creation in 1777.

\* On July 4, 1960

**UNION JACK  
(Navy)**

Always has the same number of stars as the national flag. The above dimensions are for one size. National flag copied from an official blueprint, furnished manufactures of flags for the U. S. Government by the bureau of ships. Other size flags follow these same proportions which are the scale of 1 to 19. The union Jack's proportions are the same as the canton on the national flag.

### FLAG TERMS

**Burgee:** A small triangular or swallowtail pennant

**Canton:** Upper corner of flag's own right. *The point of honor.* Also called the *Union.*

**Colors:** The national regimental, or organization flag. A banner, standard, ensign.

**Courtesy Flag:** Another nation's flag hoisted on special occasions. Example, a ship entering a foreign port.

**Ensign:** National flag flown by a naval vessel. Same as a standard in some countries.

**Fimbriation:** The narrow lines separating the colors.

**Badge:** Emblem, device, seal, usually on the field.

**Bend on:** Attach a flag to a halyard.

**Bunting:** Inexpensive cotton or thin wool cloth for flags and patriotic decoration.

**Field:** The ground of each division of a flag. The U.S. flag is divided into a red and white striped field, and a white starred field.

**Flag Hoist:** One or more signal flags on one halyard.

**Fly:** Length of a flag from end to end. Also the end away from the canton, called *free end.*

**Furl:** To wrap or roll tightly. Opposite of unfurl, meaning to allow flag to fly freely.

**Case:** Bag or container for storing the colors.

**Garrison Flag:** Large 20 by 38 feet flag.

**Grommet:** Metal eyelet for halyard.

**Ground:** Same as field.

**Guidon:** Small flag to designate guide, company's number or initial, or line or dress formation of.

**Halyard:** Rope for hoisting and lowering flag.

**Hoist:** Width of flag at canton side. To raise a flag.

**Jack:** Rectangular flag flown from Jackstaff on bow of vessel. U.S. white stars on a blue field.

**Pennant:** Triangular flag, swallowtail flag or streamer.

**Post Flag:** Ten by nineteen feet flag.

**Reeve:** To pass a rope through a pulley.

**Retreat:** Lower flag at sundown.

**Staff:** The pole a flag hangs from.

**Standard:** A banner, ensign colors. Personal banner of a ruler, flag of mounted or mechanized units.

**Storm Flags:** 5 by 9 foot, 6 inches flag flown in bad weather.

**Strike The Flag:** To lower flag as sign of surrender.

**Swallowtail:** Tapering flag with free end divided into two or more pointed tails.

**Truck:** Top of flagpole to which flag is hoisted. Often has ornament attached to cap.

**Union:** Same as canton. Also the whole of a flag as the *Union Jack* on the U.S. Naval Vessels.

**Vexillary:** A standard-bearer in ancient roman legion.

### HOW WELL DO YOU KNOW "OLD GLORY"?

Can you draw an accurate picture of the flag? Most of us could do a reasonable job, but how much of the following would be omitted from your drawing?

The flag has 13 horizontal stripes of equal width, seven red separated by six white. The union or canton consists of 50 five-pointed white stars on a blue field, placed in the upper quarter next to the staff and extending to the lower edge of the fourth red stripe from the top.

The union has nine staggered rows of stars, with six stars in five rows and five stars in four alternating rows, each with points upward.

**CRAFT**

**Mini-Busts**

Here's a novel idea that will allow you to use an assortment of famous Americans on your banquet table, all the way from Pocahontas to the most recent astronauts. These *mini-busts* can be made as favors for each person at your table. The Cubs can select which famous Americans they want to use for their own family, and make them.

Materials:

- 1 - burned-out light bulb (round type)
- 1 - egg carton cup
- Assortment of colored paper, yarn, etc. for trimming.
- Glue and paint

Directions:

Decide which famous American you wish to make and find a picture which will show the hair style, clothing, etc.

Cut a hole in the bottom of egg cup and glue in light bulb. Paint white or flesh colored. If you use the pastel colored Styrofoam egg cartons, you won't need to paint the bases. If you use pulp egg cartons, paint the base any color you like.

Then begin to decorate your famous American with yarn or cotton hair, a hat if it is needed, beard, etc. Features can be drawn on with a marking pen. Use your imagination!

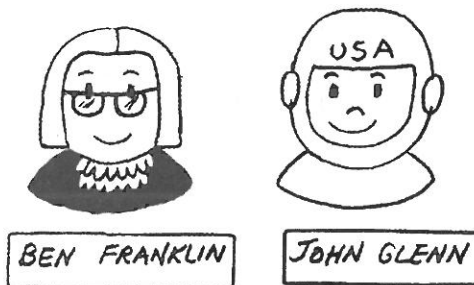
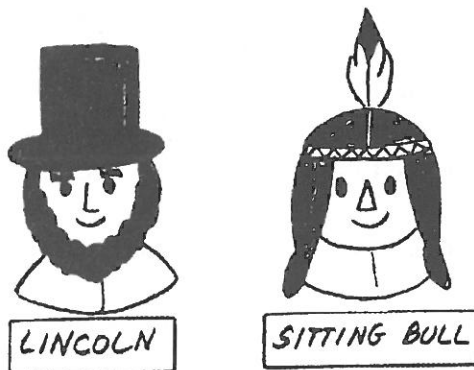
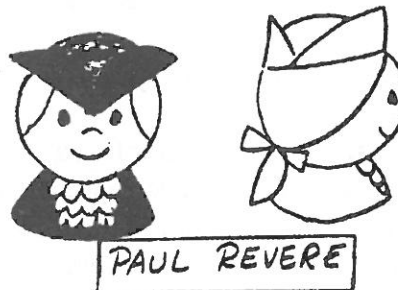
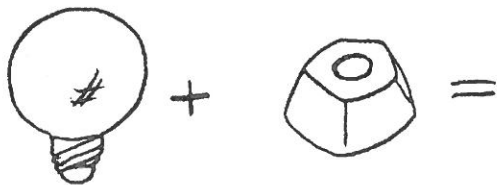

**SKITS**

**I Am An American**

**1<sup>st</sup> Cub:** My country gives each of us the opportunity to advance according to his ambition. Education is for all. I am an American

**2<sup>nd</sup> Cub:** My country means love of freedom, faith in democracy, justice and equality. I am an American.

**3rd Cub:** My country believes in the moral worth of the common man. I am an American.

**4th Cub:** My country gives us the privilege of expressing beliefs or opinions without fear of persecution. I am an American.

**5th Cub:** My country has the best form of government. It is our duty to keep it that way. I am an American.

**6th Cub:** My country promises life, liberty and the pursuit of happiness. I am an American.

**7th Cub:** My country gives us a privilege that we shall protect and defend even with our lives. I am an American.

**8th Cub:** My country is and always shall remain the land of the free and the home of the brave. I am an American.

**9th Cub:** My country offers a living Americanism which demands an informed intelligent and active citizenship. I am an American.

**10th Cub:** My country meets any need or suffering with its abiding love and loyalty. I am an American.

**11th Cub:** My country is the servant...not the master. I am an American.

**12th Cub:** My country possesses a Statue of Liberty whose torch shall burn as long as we keep it alight with our devotion to the freedom of the individual. **I am an American.**

### Stars and Stripes

I am your flag

I was born June 14, 1776.

I am more than just cloth shaped into a design.

I am the refuge of the world's oppressed people

I am the silent sentinel of freedom.

I am the emblem of the greatest sovereign nation on earth.

I am the inspiration for which American patriots gave their lives and fortunes.

I have led your sons into battle from Valley Forge to the dense jungles of Vietnam.

I walk in silence with each of your Honored Dead to their final resting place beneath the silent white crosses, row upon row.

I have flown through peace and war, strife and prosperity, and amidst it all I have been respected.

I am your flag.

My red stripes symbolize the blood spilled in defense of this glorious Nation.

My white stripes signify the burning tears shed by Americans who lost their sons.

### Flag Ceremony

#### Equipment:

- Red, White, and Blue poker chips or pieces of construction paper
- Silver and white stars or glitter.

#### Skit:

- (1) We are going to fix for you a treat that is really grand, and make for you a recipe - the greatest in the land.
- (2) In first we will put a heaping cup of red for courage true.
- (3) And then we will add for loyalty, a dash of heavenly blue.
- (4) For purity, we will now sift in a layer of snowy white.
- (5) We will sprinkle in a pinch of stars to make it come out right.
- (6) We will stir and stir and then you will see that we have made...

ALL: "Old Glory" (Pull out folded flag from bottom of pot and hold up for pledge and song.)

ALL: "Our flag is the most beautiful flag in the world, let us always be loyal to it."

All: **Pledge of Allegiance.**





# MARCH

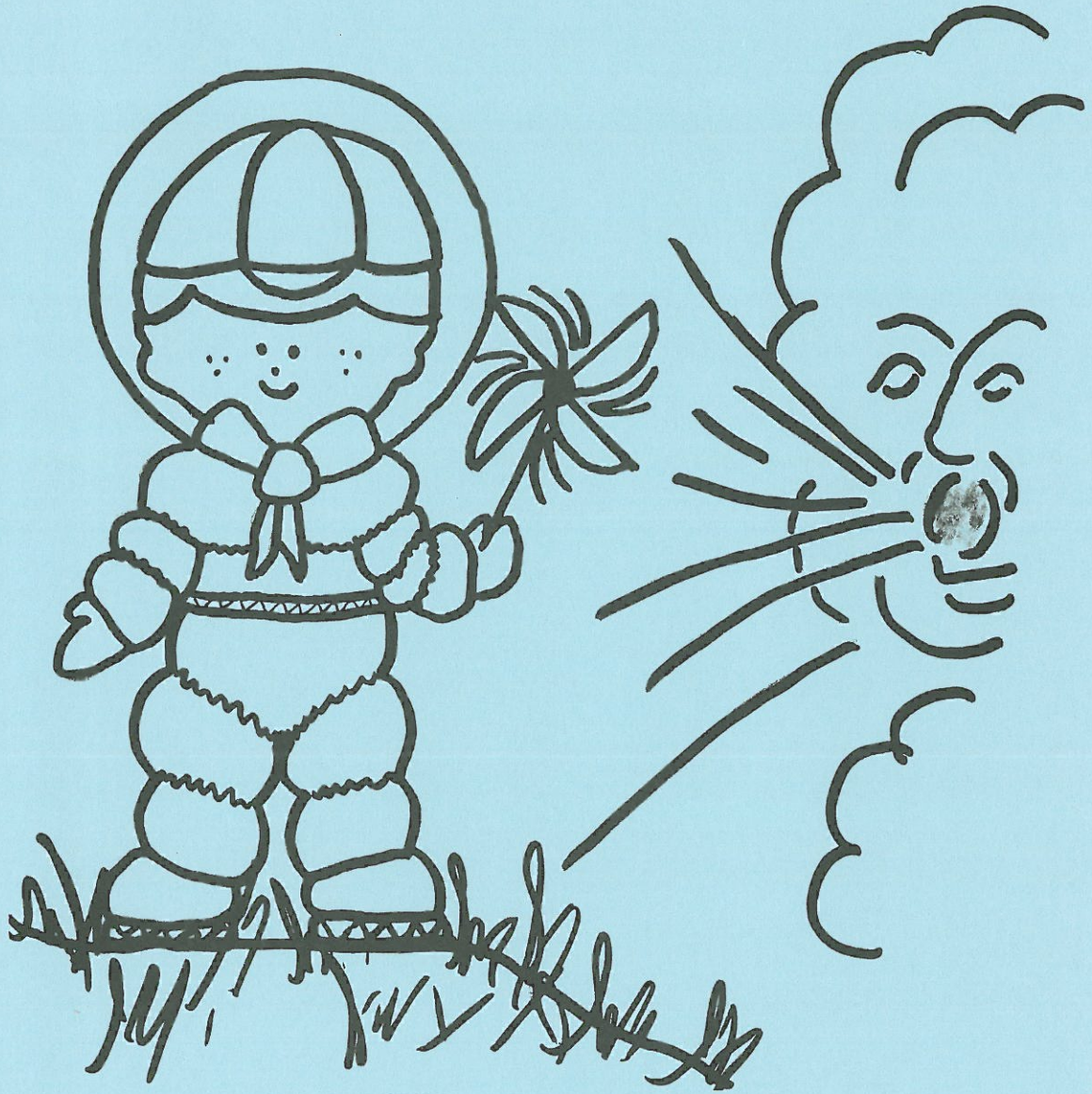

# WEATHER OBSERVATIONS



## WEATHER OBSERVATIONS

### GAMES

#### Mississippi Flood Race

Provide each participant with a glass filled to the brim with water. Holding the glass, each person must hop to a turning point and back. The one spilling the least amount of water is the winner. Variations of this would be to have the boys run, and it can be done individually or in teams.

#### Balloon Shoot

Blow up a balloon, then release it for distance from a given point.

#### Hot Air Ping-Pong

Equipment needed:

- 1 - Table
- 1 - Ping-Pong ball

Players are divided into two teams. All players kneel down around the table and should be positioned shoulder to shoulder, one team on one side, the other team on the other side. The size of the table determines the number of players possible.

Players must stay in a kneeling position and are not allowed to stand and lean over the table to gain unfair advantage over the opponent.

Players may not use lips, noses, shoulders, or any other part of the anatomy to block the ball and keep it from rolling off the edge of the table. Only lung power is acceptable.

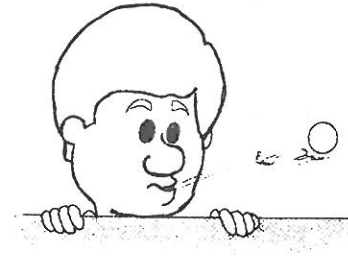

The ball is placed in the center of the table to start the game. Upon the signal to go, players attempt to blow the ball past the opposing team's defense onto the floor. Each time it goes off the table the other side receives a point.

The first team to score five points is the winner.

**Helpful hint:** Pass out a breath mint to each player prior to the start of the game!

### CRAFTS

#### A Barometer

This Barometer is a piece of paper that changes color. In dry weather it is blue, when moist, lavender; and a change in weather will record red.

To prepare, dip white blotting paper into the following solution:

- 4 oz water
- 1 oz chloride of cobalt
- 1/2 oz common salt
- 75 grains calcium chloride
- 1/4 oz gum Arabic

This will yield about 50 barometers.

As soon as the blotting paper is dry, set your imaginations loose. Cut into pieces to fit into a picture. Paste this onto a piece of wood or cardboard and attach a string of ring to the back.

**Porcupine Planter**

Materials needed:

- 2 - Potatoes
- 8 - Golf tees
- 4 - Thumbtacks
- Dirt
- Grass Seed

Directions:

Scoop out center of potato, leaving a solid shell. Fill with dirt. Scatter grass seed (rye grass grows fast) over the top of dirt. Water. Place one in the shade and the other in the sun. See how fast the grass in the sun grows compared to the one in the shade.

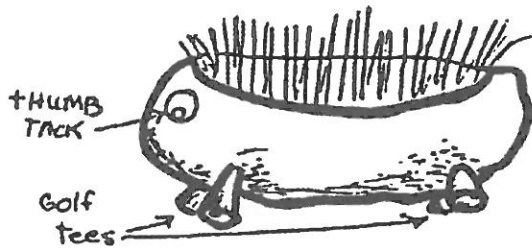

fly very differently from planes that have. They will not go as far, but they will float much better and stay up in the air much longer.

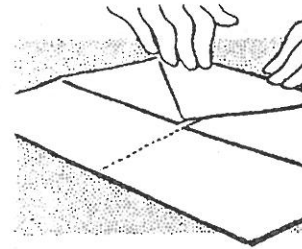

To make a plane without a keel, start out as if you were making a cutout plane. Starting with Diagram 1, Fold the paper in half the short way, and fold the ends in to make a point. then fold the tip of the point down so that it meets at the cross line.

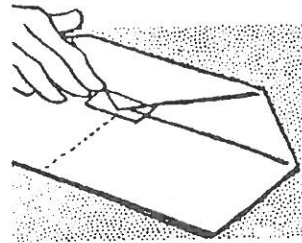

**High-Gliding Planes**

The keel of a paper plane does lots of things to help it fly. It makes the body of the plane stiff, it keeps it pointed in the direction in which it was aimed, and it also makes the plane easy to launch.

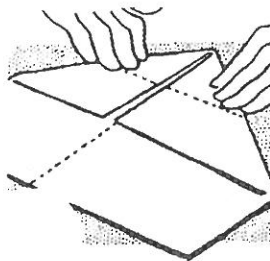

Now take a small piece of scotch tape and fasten down the point. Fold the whole plane in half along the center crease, and cut it into shape just like before. In addition, try cutting a hole in it, just in back of the spot where the point is taped down. The easiest way to do this is with the plane folded in half.

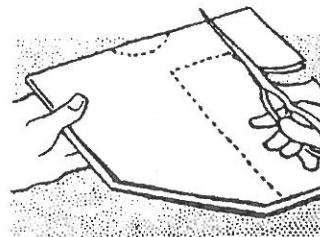

But there is no rule that says a plane must have a keel, even though most of them do, and of the cutout planes can just as easily be made without one. But planes without a keel

When you have finished cutting the plane out, don't fold down wings. Instead, just open out the plane up flat. That's all there is to it. Your plane is ready to fly.

**Airplane Weather Vane**

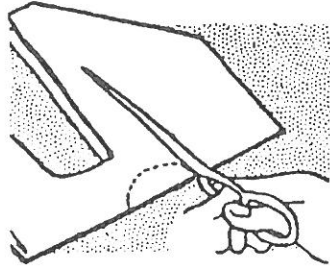

**Supplies needed:**

- 1 - 12" piece of 1"x 4" wood
- 1 - 9"x 6" piece of 1/4" plywood
- 1 - 2" length of 5/16" tubing
- 1 - large nail and washer
- sand paper and paint

This kind of plane needs to be launched very gently, just like a flying wing. Hold it at the tail, between your thumb and first finger. Give it a little nudge, and let it go. It should float in the air very smoothly, and glide to a gentle stop. You can make flaps and curl the wings, just like with any other kind of plane.

Use the pattern (next page) to cut the body from the 1 x 4. Cut the wings from the 1/4" plywood. Sand the wood smooth. then glue the wings onto the body. Let the glue dry before further work. Before painting the plane, find the pivot point under the plane where it balances evenly. Drill 5/16" hole 1/2" deep. Insert the piece of tubing into the hole and glue it in place. The plane is then ready to paint.

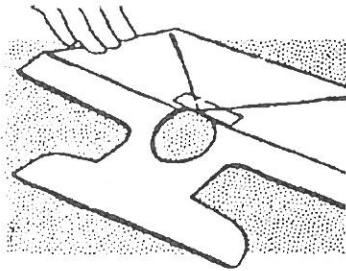

To put up the weather vane cut the head from the nail and drive the nail into whatever the vane is going to set upon. Drive it deep enough so that the tubing touches the wood. Then put the washer on the nail to act as a bearing for the tubing. A small amount of grease or Vaseline will help the plane pivot.

(See example below.)

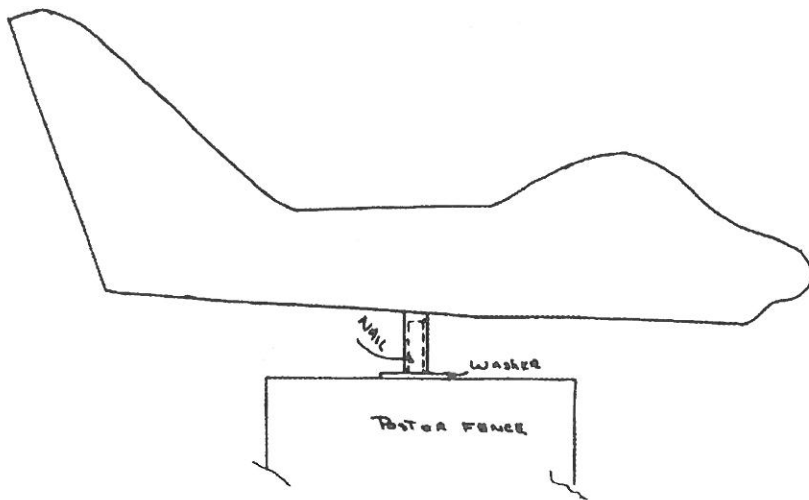

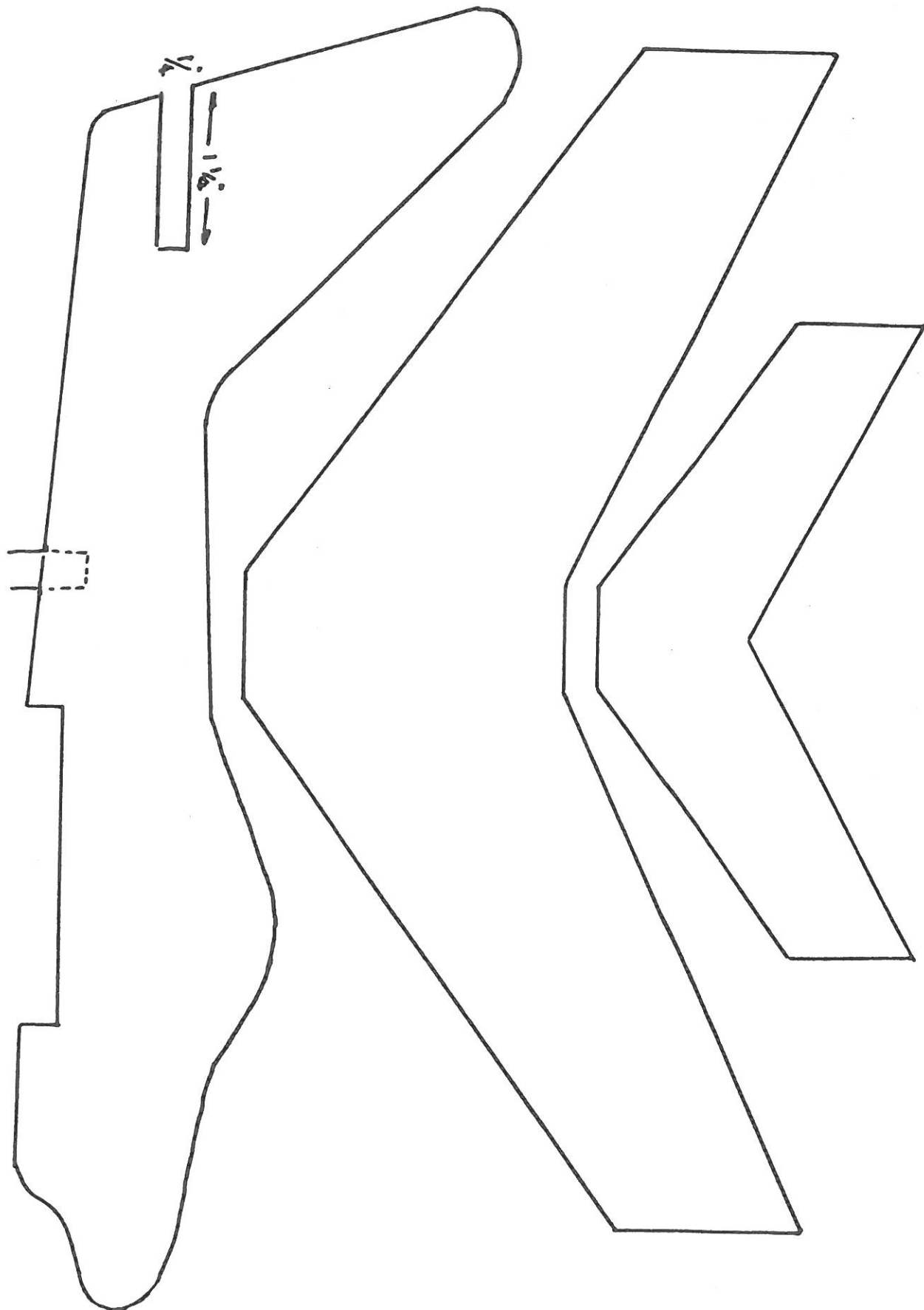

**SKIT**

**The Invisible Kite**

- 1<sup>st</sup> Cub:** Hi!
- 2<sup>nd</sup> Cub:** What's that?
- 1<sup>st</sup> Cub:** My kite.
- 2<sup>nd</sup> Cub:** What kite?
- 1<sup>st</sup> Cub:** That kite.(points up)
- 2<sup>nd</sup> Cub:** I don't see a kite.
- 1<sup>st</sup> Cub:** Well, it's there. Would you like to fly it?
- 2<sup>nd</sup> Cub:** Yes (1<sup>st</sup> cub hands imaginary kite string to 2<sup>nd</sup> cub.)

(Continue same dialogue until all your den is holding onto the same string.)

- 1<sup>st</sup> Cub:** So you guys really believe there's a kite up there and your flying it?
- All Cubs:** NO!
- 1<sup>st</sup> Cub:** Then why are you pulling on the string?





APRIL

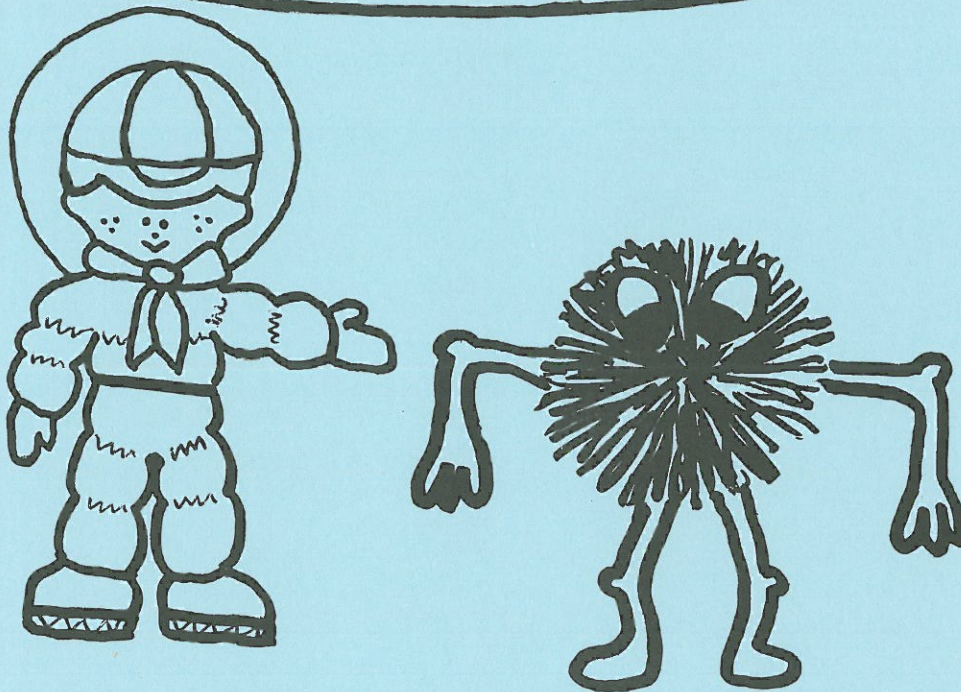

LIFE ON OTHER  
PLANETS



## LIFE ON OTHER PLANETS

### GAMES

#### Atomic Challenge

You are part of a special team trained to safely move atomic material. The container in the center is in danger of leakage. Your job is to move it safely to the decontamination zone without spilling the contents. This fun game challenges you with team work, cooperation, and finesse. This game is designed for six to eight participants.

#### Equipment Needed:

- One small inner tube (inside hole of tube should be a little smaller than the bucket)
- One 10 foot rope per player
- One empty bucket
- Two, twelve to eighteen feet circles marked off

Tie one end of each rope at intervals around the inner tube.

The bucket containing the "Atomic Material" is placed in the center of the large radiation zone circle.

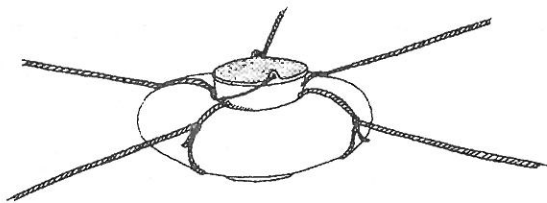

The participants must use ropes and work together to stretch the inner tube over the bucket and then release the pressure slightly so the tube holds onto the bucket. As a team move the bucket containing "Atomic Material" into the decontamination zone

circle, which is the safe area. Participants cannot enter either circle if they are eliminated from the game.

A variation of this game is to have the players play blindfolded and follow the directions of the leader.

#### Flying Saucer Landing

#### Equipment Needed:

- Frisbee
- 3 ropes of different lengths to form 3 rings for landing pads.
  - One ring to be marked 10 points, another 15 points and the 3rd, 25 points. Mark rings from largest to smallest with the smallest being 25 points.

Each boy stands 10 feet from the landing pads and tosses the Frisbee to land on a landing pad. Each boy receives 3 tries. Of the three tries the scores are added and this is the Cub Scouts score.

#### Space Man

#### (Variation of musical chairs)

Arrange a line of chairs so that they face in alternate directions. Have just enough so that every player can sit down, except one. He is the Space Man who walks around the outside of the line. Each sitting person must think of some planet, star or constellation, or something that exists in space. They continue to sit there as the Spaceman walks around the line, calling out all the names he can think of; Pluto, Mars, Venus, Sputnik, etc.

When the Spaceman calls out something that a person is thinking of, this person must rise and follow him. He joins in by calling out names that have not already been called.

Before long the Spaceman has a trail of satellites following him. After most of the people are up the Spaceman calls out: "*Falling Meteor*". Everyone tries to find a seat. This leaves one person in outer space. (still standing) Those who were still seated must tell what heavenly body they were thinking of.

### Sun Spot Tag

You need a sunny day and wall. (Game works best if the wall is in shadow so the spots show up well) Give each Cub a small pocked mirror. Hold mirror so it reflects a spot of sunlight on the wall. After a short practice moving spots around, choose an "It". It chases the other players' spots around the wall with his spot. When It's spot touches another spot, the owner of that spot becomes "It".

### Astronaut Training

Equipment Needed:

- 2 - bean bags
- 2 - jump ropes
- 2- rubber balls

This is a good physical fitness relay. Divide players into two teams and stand behind starting line. At a turning line, 15 feet away, are 3 items, jump rope, bean bag, and ball. On signal, first player from each team runs to turning line, takes jump rope, jumps 10 times, tosses bean bag in air 10 times, and bounces ball on floor 10 times. He runs back to his team, touches the next player, who repeats the action. First team to finish wins,



### CRAFTS

#### Sponge Painting

Supplies Needed:

- Sponge
- Scissors
- Dry tempera paint
- Paper

Soak the paper thoroughly in water. Lay the wet paper on a smooth surface and remove all the wrinkles and excess water. Use pieces of moist sponge which have been cut into small shapes and use as a brush by dipping them into the tempera paint.

### Rock Creatures

Smooth flat rocks can be obtained at the beach or river areas. Dirt and foreign matter should be removed by washing rocks with detergent. Be sure they are completely dry before you begin to decorate.

Use acrylic paints. If rocks are to be different colors, it is best to paint rocks before assembly. If the entire figure is one color, the rocks may be glued together first, then painted.

Use contact cement to glue the rocks together. It helps to saturate a small piece of cotton with glue and place between the rough edged rocks. They will adhere better if you do this. After pieces are glued together it's a good idea to run a collar of white glue or household cement around all joints to make a firm lasting bond.

Use your imagination in adding features, such as yarn for hair, broom straws for whiskers, chenille stems for tails, etc.

Don't try to "plan" these rock creatures. Let the boys find some of the rocks on their own---you furnish some extras. Then provide paint, glue, and an assortment of "extras". Let each boy use his imagination to create his own alien.

### SONGS

#### Rockets Away

(Tune: Anchor's Away)

Rockets away, my boys,  
Rockets away.

We're off to see the stars,  
The planets and more,

Blast off to meet new friends,  
Learn their ways and soon,

When we return we'll be  
Smarter for sure!

I'm far out in space now,  
Just touring the stars.

I'd come home in a hurry,  
But I don't know where we are.

Then I spotted a Shuttle,  
And tagged on behind,

And after a while  
Guess what I'll find,

Good old terra firma,  
The earth sure looks good.

But I'll start out again,  
Soon as I'm in the mood.

#### I Visited Pluto

(Tune: On Top of Old Smokey)

I visited Pluto, my fortune to seek,  
While I was there my spaceship started to  
leak.

It dripped on past Jupiter,  
To Venus and Mars,  
But when I reached Saturn,  
I had to trade cars.

While stopping on Mercury,  
I found no one there.  
So, I put it in high gear,  
Plotted a chart for no-where.

**Spaceship Song**

(Tune: Little House in the Woods)

Little spaceship in the sky  
Inside spacey cone-head guy.  
Sees an astronaut floating by  
Knocking on his door.  
Help me! Help me! So he said  
Or the meteorite - whiz  
Will get my head - bonk  
Come little astronaut  
Come with me  
Cone-heads we will be!  
(Repeat three times: Mini-medium-maxi.  
Use actions.)

**The Astronaut's Plea**

(Tune: My Bonnie Lies Over the Ocean)

I went for a ride in a spaceship,  
The moon and the planets to see.  
I went for a ride in a space ship,  
Now listen what happened to me.

Chorus:

Bring back, bring back,  
O Bring back my spaceship to me, to me,  
Bring back, bring back,  
O bring back my spaceship to me.

I went for a ride in a spaceship,  
The capsule was crowded and I ,  
Developed a cramp in my muscles,  
So I decided to walk in the sky.

(Chorus)

I went for a walk in my space suit,  
The ship was controlled from the ground,  
And someone in charge down at NASA,  
Forgot I was walking around!

(Chorus)

**Rocket Song**

(Tune: Turkey in the Straw)

I had a great big spaceship,  
and it's rockets wouldn't fire,

So I tinkered and I tested, but  
It only raised my ire.

I twisted every knob and I pulled  
each lever twice.

But when I touched the starter it  
ignited the device.

On past the moon, and Jupiter and Mars,  
Flying past Venus, Pluto and Stars,

When I get back I'll tell you where I've been,  
So now it's bye-bye until then

**Three Little Angels**

(verse one)

Three little angels all dressed in white,  
Tried to get to heaven on the end of a kite.  
But the kite string broke and down they all  
fell.  
Instead of going to heaven, they all went to...

Two little angels all dressed in white,  
Tried to get to heaven on the end of a kite.  
But the kite string broke and down they all  
fell.  
Instead of going to heaven, they all went to...

One little angel all dressed in white,  
Tried to get to heaven on the end of a kite  
But the kite string broke and down they all  
fell.  
Instead of going to heaven, they all went to...

(verse two)

Three little devils all dressed in red,

Tried to get to heaven on the end of the thread.  
 But the thread string broke and down they all fell.  
 Instead of going to heaven, they all went to...

I'll fly in my space ship to Mars,  
 But what if I get lost in space,  
 And can't find my way through the stars?  
 (Chorus)

Two little devils (etc.)

Our family may move to Venus,  
 I don't know what we would find there,  
 I'd sure miss my friends back on earth,  
 They're the best friends I'll find anywhere.

One little Devil (etc.)

(Chorus)

(verse three)

Three little Martians all dressed in green,  
 Tried to get to heaven on the end of a bean.  
 But the bean pod broke and down they all fell.  
 Instead of going to heaven, they all went to...

Dehydrated food for breakfast,  
 Dehydrated food for lunch,  
 Oh what I would give for a Big Mac,  
 And potato chips that I can crunch.

Two little Martians

(Chorus)

One little Martian...

Don't get excited, Don't lose your head.  
 Instead of going to heaven, they all went to bed.

**There Was An Astronaut**  
 (Tune: Bill Grogan's Goat)

**World of Tomorrow**  
 (Tune: My Bonnie)

Last night as I lay on my pillow,  
 And drifted off slowly to sleep,  
 I thought of the world of tomorrow,  
 These thoughts through my mind did creep.

There was an astronaut they say,  
 Was oh so brave, blasting off one day,  
 His wife said: "this lunch please take"  
 But the brave Astronaut, his head did shake,  
 "I cannot take any extra gear"  
 With these last words, he smiled and waved.  
 With many unknowns yet to be braved.

A computer will do all my homework,  
 A robot will do all my chores,  
 If I spend the whole day just playing,  
 I fear that I may become bored.

His wife she worried both day and night  
 To think he'd starve on his first flight,  
 But this brave astronaut, so smart,  
 Knew something important from the start,  
 Upon the moon, where he did land,  
 He enjoyed a lunch that was so grand.  
 And he felt smart and very pleased  
 When he remembered the moon's green cheese.

Chorus:  
 Bring back, Bring back,  
 O bring back the old days to me, to me  
 Bring back bring back,  
 O bring back the old days to me.

My jet powered bike will be speedy,

## SKITS

**The Moon Trip**

(An adaptation of the Bear Hunt)

Take a seated position in front of the audience so they can all see you narrate the following:

Would you like to go on a trip to the moon?  
OK, let's go! Watch me and do all the things I do and repeat after me all the things I say.  
Here we go!

We're going on moon trip. We're ready for the count down.

10-9-8-7-6-5-4-3-2-1---Blast off! (Make a blasting sound as you thrust arms swiftly toward the sky.)

We're coming to the Milky Way - what a pretty display. We can't go around it. We can't go under it. We can't go over it. I guess we'll have to slide down it. (Put feet out in front of you and hold both sides of chair as if sliding down slide while saying "Whee-eee.")

We're coming to a shooting star - A great big star. We can't go around it. We can't go under it. We can't go over it. I guess we'll have to ride it. (Hold hands as if holding coil of rope and then throw out as if to lasso a point of the star and pull pack hard while saying "zoom-oom-oom"!)

We're coming to a meteorite - a great big meteorite. We can't go around it. We can't go under it. We can't go over it! I guess we'll just have to dodge it. Ready here goes! (Dodge from side to side while saying "Whew-w-w" and while wiping sweat from brow.)

We're coming to the moon - what a lonely place. We can't go around it. We can't go under it. We can't go over it! I guess we'll have to land on it. (Jerk back in seat as if jolted on landing.) (Holding hands over eyes) It sure is dark out there. (Reach out in front of you as if grasping door knob and ever so slowly push open rocket ship door.) Just as arm is extended full length as if door is all the way open a loud voice coming from someplace close by says..."BOO"! Let's get out of here! Quickly pull arm back as if shutting door.

(At this point retrace all the motions hurriedly, Blast-off, dodging meteorite, riding shooting star, sliding down Milky Way - hold arms over head in front of you simulation a parachute, then looking down at floor say loudly "SPLASH"! Motion opening space ship door, motion swimming to shore. I beat you home, and now you've been on a trip to the moon..

**All Aboard for the Moon**

(A puppet skit)

Use any kind of puppets

**CHARACTERS:**

- 4 - cub scouts
- 1 - den leader
- 2 - moon creatures

**SCENES:**

- On the earth
- In a spaceship
- On the moon.

**DEN LEADER:** Can you imagine a den leader taking a group of Cub Scouts on a field trip to the moon? Well, I did, and here's what happened.



ALL CUBS: Yeah, let's go! Let's pack our space gear.

CUB NO. 1: We're taking our toothbrushes, toothpaste, vitamins, soap, raincoats, cheeseburgers, bicycles, roller skates, and surfboards.

(All puppets are looking out the window of their space ship.)

CUB NO. 2: There's Neil Armstrong's giant step.

CUB NO. 3: Do you think we will see a moon creature?

CUB NO. 4: There's Mr. Spock's ears!  
(Enter moon creatures.)

CREATURE NO. 1: Oh, no! There's another group of tourists!

CREATURE NO. 2: Get the moon rocks ready to sell.

ALL CUBS: Let's split. It's a nice place to visit, but we wouldn't live here!

### A Space "Odd-Odyssey"

Divide the audience into three groups to respond to the following words:

- 1) THALASH: "glob, gleep"
- 2) FLYING SAUCER: "I see it"
- 3) AFTER THE NAME OF ANY HEAVENLY BODY: "NASA, Yassuh!"

THALASH\_\_\_\_, a one-eyed, one-horned, three-legged flying, furry foreigner from far off JUPITER\_\_\_\_, one day jumped (at least it was a close approximation of jumping) into his FLYING SAUCER\_\_\_\_, a deluxe, specially sooped up Centurion Super Six, and zapped his way across the MILKY WAY\_\_\_\_ at what some would say was a frightful speed.

As his FLYING SAUCER\_\_\_\_ sped past BETELGEUSE\_\_\_\_, the other major star in the constellation ORION\_\_\_\_, THALASH\_\_\_\_ bid a fond farewell to his home and set a course for an area adjacent to URSA MAJOR\_\_\_\_, the BIG DIPPER\_\_\_\_, and URSA MINOR\_\_\_\_, the LITTLE DIPPER\_\_\_\_, to visit a small solar system he'd been studying in his search for other intelligent beings, and from which emanated electrical disturbances on many wave-lengths.

Using the relatively small, yellow STAR\_\_\_\_ as a beacon, he eventually found his way to the system he sought...nine PLANETS\_\_\_\_ and a narrow ASTEROID BELT\_\_\_\_. Maneuvering his FLYING SAUCER\_\_\_\_ deftly about, he first decided the biggest PLANET\_\_\_\_ with the most MOONS\_\_\_\_ must be the dominant one. But there were no inhabitants, no vast electrical disturbances, just a surface raging with methane storms. So THALASH\_\_\_\_ fired up his sooped up Centurion Super Six FLYING SAUCER\_\_\_\_ once again and headed for the third PLANET\_\_\_\_, where he had noticed evidence of activity.

Drawing close, THALASH\_\_\_\_ first encountered two strange little white objects in orbit. The first had been launched many years ago, with nothing more than a piece of wood, by a sport's figure named "Babe". The second had been launched more recently by a figure from the same sport named "Hank". He also ran across some artificial satellites and debris.

THALASH\_\_\_\_ monitored the high and low frequency waves emitted from various spots, and learned that this PLANET\_\_\_\_ was called EARTH\_\_\_\_ by its inhabitants. He learned that in the area known as North America, another one of those strange bursts of electrical energy would take place in less

than two revolutions of the PLANET\_\_\_ and learned its cause. Two days later, THALASH\_\_\_ was nearly blasted out of orbit as something called the Super Bowl flashed on his viewing screen. Viewing it as a primitive form of combat, THALASH\_\_\_ judged the inhabitants to be at a low rung on the evolutionary ladder and headed his Super Six FLYING SAUCER\_\_\_ once again for home. He was disappointed in not finding really intelligent life in this sector of the GALAXY\_\_\_. "Oh well," thought THALASH\_\_\_. "Maybe I'll have better luck next time."

--Gerald L. Lohman  
San Diego County Council

### Trip to the Moon

This audience participation is adapted from a Buffalo Trace Council story. Assign one of the following characters and their sounds or phrases to each audience group, then read the story. As each character is mentioned, the proper group rises and repeats the appropriate sound or phrase.

Characters include:

*Captain Audio*---"Moon or bust"  
*Lieutenant Cheerio*---"Rockets away"  
*Rocket Ship*---"Zzzzzzooooommm"  
*Eagle* ---"Creeecreee"  
*Satellite*---"Whirl, whirl"  
*Radio* ---"Bleuurp, bleuurp"  
*Shooting Star*---"Bang, bang"

Everyone was watching as some men came out of the control tower. They were *Captain Audio*\_\_\_ and *Lieutenant Cheerio*\_\_\_ who were headed for their *Rocket ship*\_\_\_. *Captain Audio*\_\_\_ climbed into the cockpit and strapped himself into his seat. *Lieutenant Cheerio*\_\_\_ climbed into his place next to *Captain Audio*\_\_\_ fired the

rockets to make the *Rocket Ship*\_\_\_ leave the ground and head toward the moon.

As they reached outer space, they heard a strange noise on the hull of the *Rocket Ship*\_\_\_. It was a lonely *Eagle*\_\_\_, hanging on for the ride. *Lieutenant Cheerio*\_\_\_ snapped on the *Radio*\_\_\_ to tell the people on earth about the *Eagle*\_\_\_, but all he got was static. Further on, the *Rocket Ship*\_\_\_ passed a *shooting star*\_\_\_ and a *Satellite*\_\_\_, *Captain Audio*\_\_\_ and *Lieutenant Cheerio*\_\_\_ waved, while the *Eagle*\_\_\_ climbed onto the *Shooting Star*\_\_\_ that was headed in the same direction. He was tired of riding on the smooth side of the *Rocket Ship*\_\_\_. The pilot tried to tell earth, but his *Radio*\_\_\_ still sent nothing but static.

Soon they could see the surface of the moon very clearly. *Lieutenant Cheerio*\_\_\_ warned *Captain Audio*\_\_\_ to steer clear of the *Satellite*\_\_\_ ahead, but to their surprise it turned out to be the *Eagle*\_\_\_ riding on his *Shooting Star*\_\_\_. They got closer and closer. Slowly they let the *Rocket ship*\_\_\_ down for a landing. When it touched, out climbed *Captain Audio*\_\_\_ and *Lieutenant Cheerio*\_\_\_. Next to them landed the *Eagle*\_\_\_ on his *Shooting Star*\_\_\_ that they had mistaken for the *Satellite*\_\_\_. A strange creature approached them and they all realized it was the "man in the moon". As *Captain Audio*\_\_\_ reached out to shake hands with the creature, it said, "Sorry, but we are not made of green cheese. We are made of static."

At this point, the creature slowly sank out of sight.

MAY

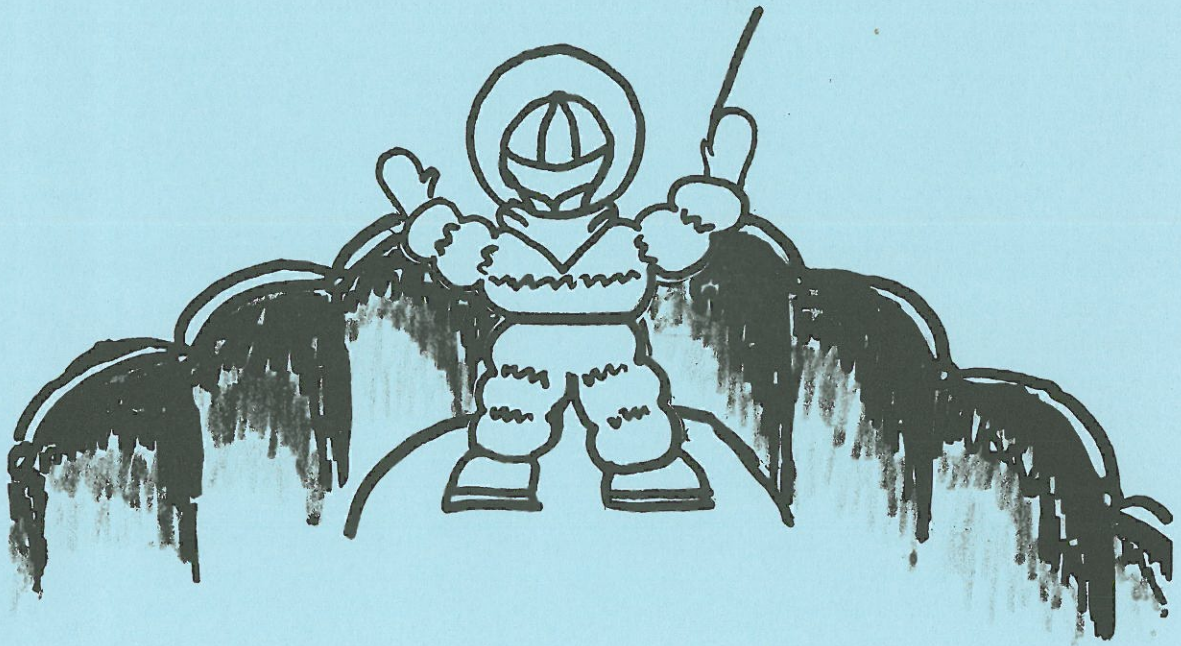

SHOW BIZ



## SHOW BIZ

### GAMES

#### Candy Bar Scamper

Dress up for a fast junk food attack!

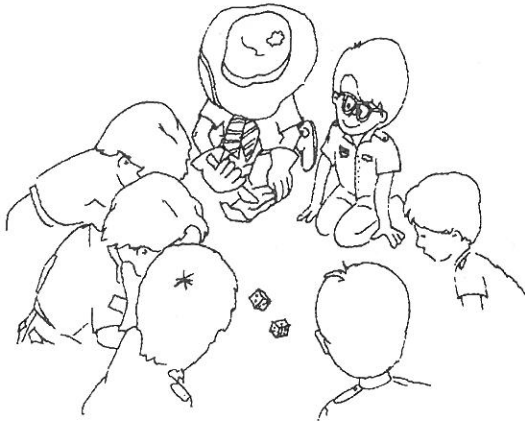

#### Equipment Needed:

- Old hat
- Necktie or scarf
- One pair of gloves
- Butter knife
- Fork
- Assorted candy bars individually gift wrapped
- One pair of dice

This game is designed for four or more players. Everyone sits on the floor in a circle. One person must dress up in the clothing items named above.

The person to his left has the dice. Upon the "GO" signal the "dressed up person" tries to quickly open a gift wrapped candy bar with the butter knife and fork, while the player to his left begins to roll the dice.

Each player gets three tries to roll doubles. If that player is successful, he quickly passes the dice to the person to his left. As soon as someone has rolled doubles, the clothes,

knife and fork are quickly passed to that person. That player then puts on the clothes and has a chance to extract the candy from it's wrapping, while the others are attempting to roll doubles.

Play continues until all the candy bars are successfully removed from their wrapping.

**CAUTION:** This game can become very fast and frantic. Be careful not to throw the utensils when changing players.

#### Creative Dramatize (Pantomime)

Fill a large bowl with slips of paper on which is written instruction such as:

(All over body activities)

1. Bat balloons high into the air.
2. Skip rope all around the room.
3. Crawl through a thick jungle full of long-hanging branched and heavy vines

(Smaller aspects of body talk)

1. Have one boy pitch a ball and another catch (asking such questions as "Will the ball be pitched high? Low? Hard?")
2. Walk a tightrope in the air.
3. Follow a buzzing fly around the room and finally swat it.
4. Brush teeth, wash hands and face.

(Animal pantomime)

1. A cat waking up from a nap.
2. A cat watching a bird.
3. A cat rubbing up against a person's leg.
4. A cat curling up and going to sleep.

(Then try these)

1. A dog walking along, sniffing the ground.
2. A dog sitting up and begging.
3. A person being nice.
4. A person looking mean.

(Mood pantomime)

1. No school today.
2. The picnic has been called off.
3. I have the measles.
4. We're lost.

This form of charades is fun for the boys as well as a direct learning exercise for warming up to pantomime. Choose your skit and play charades with it first. Your boys will be practicing as well as having fun, then you can get down to business in a much lighter mood.



### Can't Be Done

This one looks easy, but it can't be done. Place both heels against the wall and then try to pick something up from the floor.

### Quick Change Relay

This is a fast, furious relay with a twist.

Equipment Needed per team:

- One hat
- One overcoat
- One necktie
- One pair gloves

Players are lined up in relay formation with no more than six players per team. Relay teams are divided in half and are about 30 feet apart.

On the "go" signal the first player in line puts in the hat, overcoat, necktie, and gloves and races to his awaiting teammates. He then takes off the relay clothes and his teammate puts them on and returns to the starting point. Play continues until each person has participated. The first team to have all players make the quick change and cross the finish line is the winner.

### Strong Paper

Ask if any one has seen the new strong paper that will support a glass. Show an ordinary piece of paper and lay it as a bridge between two glasses. Naturally it won't support a glass. In order to do it you simply pleat the paper. For best results, make pleats about 1/2' wide.

### Pack Man

Each person is given 5 pieces of plastic fruit. Place one piece between the knees, one under the chin and one under each elbow. The last is placed on the floor. Player must get to the finish line, deposit 4 pieces into an open grocery sack and kick the last piece over the line without using their hands.

## CRAFTS

## Clown Mobile

## Materials Needed:

Construction paper,  
Thread,  
Paste,  
Scissors

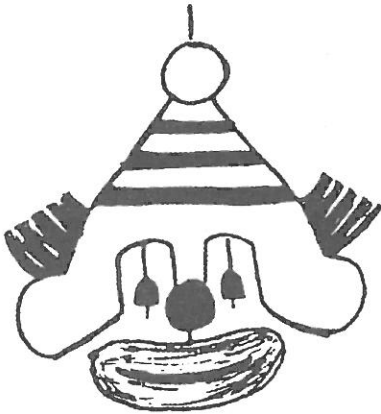

Cut out two clown heads. Cut two hair pieces and three 2" threads. When pasting the heads together, position and paste hair and threads between the heads. Cut out two red noses, and paste one on each side of head. Cut out two yellow balls, and paste on tip of hat, placing thread between to hang mobile. Cut out four eyes, and paste on each side of threads. Cut out two pink mouths, paste together with thread between.

## SKITS

## Water, Water

**Scene:** Groans of a clown come from distance. He calls, "Water-r-r". Gradually he crawls on stage, dragging himself. When he reaches the water hole he takes a dipper, drinks the water, spits out some screams "POISON!" and drops.

The bucket has a little rice or confetti in the bottom and some water in the dipper, which is carefully replaced.

Other clowns come in and drink, with the same results, each screaming "POISON!" and dropping. When the last one is just about to drink, the first one, supposedly dead, springs up and screams, "DON'T DRINK THAT WATER, IT'S POISON!" and grabs the bucket, hurling its contents out over the audience, who knows there is water in the dipper and expect a bucket full on them!

## Push-Button Skit

**Scene:** A TV fan, changing channels willy nilly, gets the following program all mixed up: A football game, gangster story, Boy Scout program, home economics (recipe) program, and the children's story hour.

**Gangster:** (tough) Okay, wise guy, I got you dead to rights, see! One false move and you're a dead pigeon, see! Try to take my doll away from me eh! Why, you cheap, chiseling punk, for two cents I'd.....

**Recipe:** (calm) set carefully in 2 1/2 quarts of boiling water. Then when the entire mixture has heated to the boiling point, again, slowing stir in the whites of two eggs and.....

**Story Teller:** (sweetly)..Little Red Riding Hood. Yes, children, today I'm going to tell you the story of the little girl who went through the woods to grandmother's house all by herself. Once upon a time, there was a little girl who lived at the edge of a great forest. One day the little girl said to her tiny gray-haired little mother.....

**Boy Scout:** (loud and clear) How would you like to join the Boy Scouts of America? There's a troop in your neighborhood, you know. Yes, you too can join the ranks of the Boy Scouts of America, the number one organization for boys and young men. And what red-blooded American boy has never said to himself.....

**Gangster:** ...Now there's a dame I could really go for! Yes, ya mug, I don't care if she was your doll, from here on in, see, and if you don't like it you can.....

**Recipe:** ...slip your hand into the oven, preheated to 475 degrees Fahrenheit. Bake about 60 minutes, then open the oven door and.....

**Football:** .....Wow, what a mess. Yes sir, after that last pile-up Smorgorski looks like he's been through a meat grinder and the coach is pulling him out right now. There goes his substitute. Let's see, it's number 79 folks, and that means it's.....

**Storyteller:** .....the sweet, white-haired old grandmother. But it wasn't her grandmother. It was the wolf dressed in Grandmother's clothing. And Little Red Riding Hood said, "My, what big eyes you have, grandmother." And the wolf said.....

**Gangster:** ....brother, what a schlemiel you are! Why don't you drop dead and save me the trouble of putting this slug through your lousy yellow hide. Steal my girl, will ya! There's one thing that can save yuh now, pal, only one thing that can save yuh now.....

**Boy Scout:** .....The Boy Scouts of America!.....

**Recipe:** .....and ladies. I think you'll agree that's really ham! Not a speck of fat on it,

and that's the way it should be, lean and juicy and so full of.....

**Football:** .....unnecessary roughness. So, it's a 15 yard penalty for the Aggies way back on their own--oh, oh, there's a big argument with the referee. The Aggies Captain is shouting and waving his arms, and I can just imagine what the referee's saying to the Captain.....

**Story Teller:**.....My, what a big mouth you have, grandmother! And at that moment, the wolf threw off the grandmother's bed clothing and said, "All the better to eat you with, my dear!" And Little Red Riding Hood cried, "Save me! Save me! Who will save me?"

**Boy Scouts:** The Boy Scouts of America...

**Football:**.....and brother, are they confused! Oh, oh, he's gonna pass on this play. He gets it off --- It's a long high wobbling one going far down the field. There it goes, wow! It's heading right for the.....

**Recipe:** ....Automatic waffle iron and sandwich toaster. And, of course, if you remove the waffle or sandwich too late, it will be.....

**Football:**.....thrown for a loss. Too bad. That was a good pass, but the big end from Southbend rose up and said, "Nothing doing, boys. It's mine." Yes sir, these Aggies are one terrific team, I'm telling you! For my money, there's only one outfit in the country today that could take the Aggies and that's....

**Boy Scout:**....the Boy Scouts of America! Yes, just think, fellows, of the swell times you'll have in camp this summer; lots of hiking and swimming and good eats, and in the evening, gazing into your campfire and



logbook with no company but the wind and the stars and.....

**Story Teller:**.....Little Red Riding Hood. Yes, children, Little Red Riding Hood was safe, too. And as for the wolf.....

**Football:**.....I'm afraid he'll never play football again, folks. he was hurt pretty bad on that play, and both sides took time out. We remind you that you're listening to the broadcast through the courtesy of Sharpo, the razor whiskers are afraid of. With Sharpo, the sharpest razor in the world.....

**Gangster:**.....you can cut your own throat, for all I care, ya jerk. Whatsa matter? Ya scared? Whatcha scared of? Whatcha scared of pal? What's a big strong guy like you afraid of?

**Boy Scout:**.....The Boy Scouts of America.

### The Disappearing Bandanna

Props: 4 or more assistants and one ripe banana

Characters: 5 deadpan assistants and an announcer.

Setting: Tell the audience you are going to perform a magic trick for their enjoyment. Before their eyes the assistants will demonstrate the disappearing bandanna trick. The assistants have been carefully selected for their ability to follow directions exactly. Four assistants take their places behind the announcer. Bandannas are concealed in the hip pocket. The banana is carefully kept behind the 'dolts' back.

Announcer: (Straight faced at all times) Remove the bandannas from your pockets and show them to the audience. (Note: hold

the bandanna in front of you and show both sides. The one with the banana shows a banana with confidence.)

Announcer: Fold the bandanna in half again (Note: everyone folds the bandanna again to a smaller square. The one with the banana expresses more concern, looks left and right, uses facial expressions to demonstrate an uncomfortable feeling. He breaks the banana again.)

Announcer: Hold the bandanna in you left hand and fold in the four corners. (Note: Everyone complies. The one with the banana sort of scoops up the fruit and piles it in the center of the palm of the left hand. Facial expressions should be appropriate to show concern that something he is doing is different from everyone else.)

Announcer: Make a fist. (Note: By now everyone in the audience is watching the banana. The hands with the folded bandanna are discreetly exchanged --the left for the right. The bandanna is placed in the hip pocket. The banana by now is oozing from between the fingers and the audience is usually in tears.)

Announcer: Open your hand and show that the bandanna has disappeared. (Note: Of course it has and applause is appropriate.)



JUNE

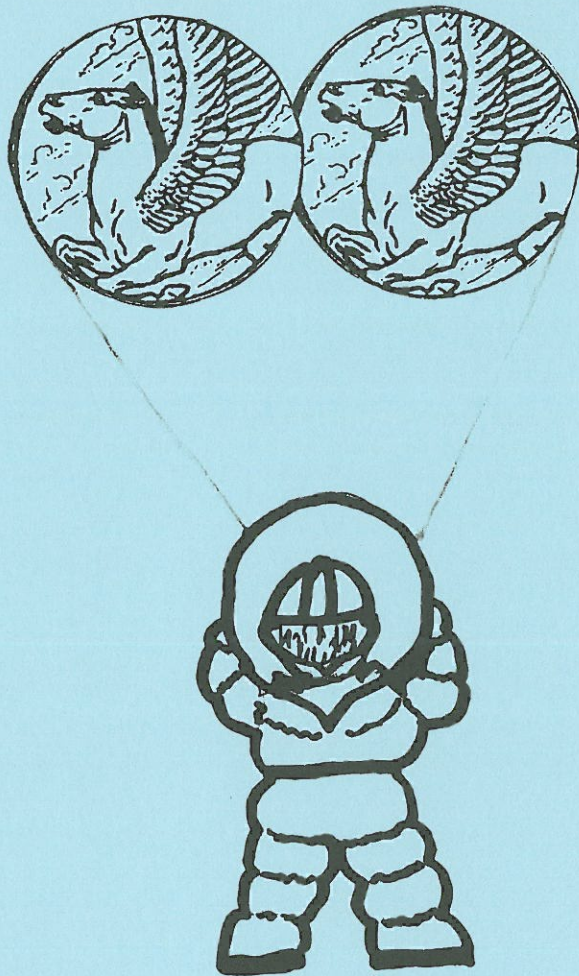

CUB SCOUT BIRD  
WATCHERS



## BIRD WATCHERS

### GAMES

#### Bird Hunt

While everyone stands in a circle, pin the name of a bird on each Cub Scout's back. Give each a pencil and a card. The object is to find the names of as many birds as possible while avoiding showing his own back. No one may stand still with his back against a wall or tree.

### CRAFTS

#### Paper Plate Owl

With rounded sides out, staple two paper plates together around the rim. Make each wing by folding another plate in half, without creasing, and staple it near the top of the body. For the head, fold about one third of a plate over and staple it. Attach to the body with more staples.

Paint the owl and add details with cut paper and markers. Slip a piece of yarn through the fold of the head. Knot the ends together.

#### Fluffy Owl

Dab glue between the petals of a pine cone. Stuff a thin layer of cotton between these petals. Glue a yarn loop on top of the pine cone. Blue on feet and facial features cut from felt.

#### For Hungry Birds Only

How about making a bird feeder for your feathered friends who remain in your back yard during the winter? If they give you a

song, it seems that it is only fair that you should give them a supper worthy of that beautiful chirping!

Before you decide that, yes, you would like to feed the birds this winter, remember that you must continue feeding them without interruption until spring. Birds establish firm winter feeding territories. No matter how hungry they get, territorial considerations keep them within a certain area. So, when you set out that first bird feeder, it's like promising the birds, "I will set food for you here all winter long." Be sure you mean it!

Be a good host to your flying friends. In addition to setting out food for them throughout the winter, remove any snow which may cover the feeder. It'll make dining so much more pleasant.

Certain birds prefer certain foods. No one food will satisfy all birds, so experiment with a variety of main courses for your feathered guests.

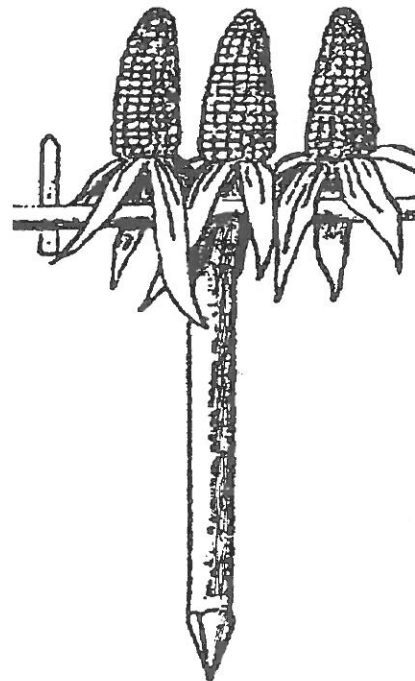

When using peanut butter, mix it with seed or suet. Crush eggshells into tiny pieces and mix it with suet or peanut butter (a good way for birdies to get their calcium). White bread isn't as nutritional as other foods, but it's a good way to lure birds to your banquet table.

There was a Scandinavian custom at Christmas of tying a sheaf of wheat or oats to a long pole. The pole was raised on Christmas Eve for the birds to enjoy. Each family would compete with the others to see how high it could raise its pole.

You can do the same thing. If you don't have wheat or oats, substitute corn on the cob or pieces of bread. The birds will love it.

Cover a pine cone with peanut butter. Then roll it in birdseed. With string, hang the pine cone from the branch of a tree.

### Slapstick Wren House

**1. MAKE THE FLOOR.** Lay 10 sticks flat and parallel so they touch. This is the floor for your Wren House. Spread cement on the bottom of the cork triangles that will make the walls of the house and set them into place, one at each end of the floor running crosswise to the sticks so that each stick is cemented to the cork triangles.

**2. MAKE THE ROOF.** Spread cement on the slanting sides of the triangles and start laying your sticks across beginning at the top. Put the very top one standing on its side. For extra strength put a little glue on the sides of each Slapstick before you put it in place.

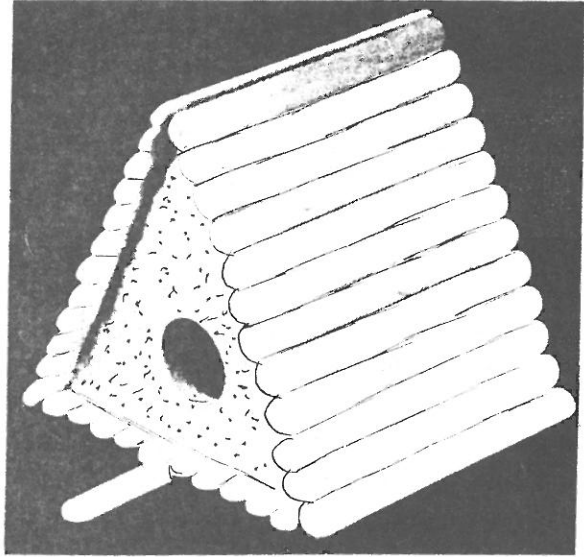

**3. ATTACH A PERCH.** Finish your Wren House by cementing the remaining stick in place for the perch as shown in the illustration. You may wish to spray paint it or dye it by dipping into a deep vessel of dye. Either nail it to a tree branch, garage or attach a string or wire to the top and hang it from limb of a tree or on a hook on house or garage.

### Mystery Bird

Here's a balancing act to mystify your friends. Make this colorful little bird that balances on the tip of your finger the edge of the table, or the rim of a glass. Trace the actual-size pattern on a piece of heavy cardboard. Cut out bird and color. Tape a penny to the underside of each wing. With a little practice you can make it appear to fly by balancing it on your finger and raising and lowering your hand. (Mystery Bird Pattern on next page,)



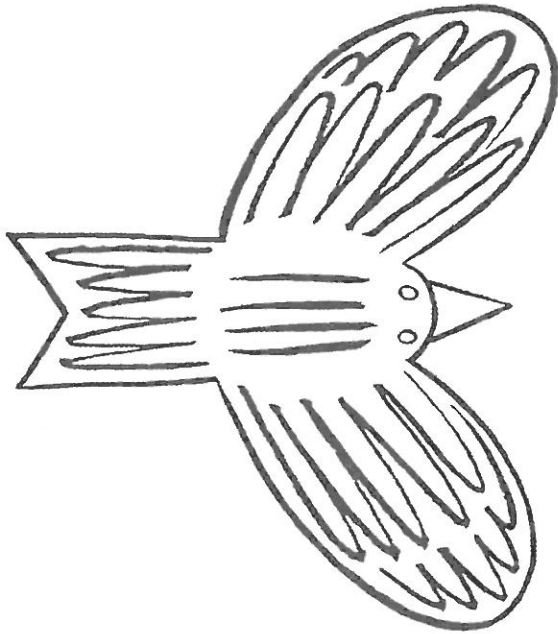

## SONGS

### Kookaburra

Kookaburra sits in the old gum tree,  
eating all the gumdrops he can see.  
Stop kookaburra stop kookaburra  
save some there for me.

Kookaburra sits in the old gum tree,  
merry, merry king of the bushes he.  
Laugh kookaburra, laugh kookaburra,  
gay your life must be.

Kookaburra sits on the railroad track,  
along came a train and knocked him flat.  
Cry kookaburra, cry kookaburra,  
sad your life must be. Boo Hoo Hoo

Kookaburra swims in the ocean blue,  
along came a wave and knocked him  
through.

Swim kookaburra, swim kookaburra  
wet your life must be. Glub, Glub.

## SKITS

### The Bird Astronaut

Characters:	What they say:
Reader:	...
Woody:	Peck, Peck
Robin:	Bob-bobbing
Blue Jay:	Twitter, twitter
Oriole:	Ta-wheet, ta-wheet
Rocket:	Vroom, vroom

As the name of the individual character is mentioned and the dash appears, the person assigned to be that character rises and makes the sound indicated for that character.

### Story:

Woody\_\_\_\_\_ was a bird,  
A Woodpecker with ambition,  
He fancied he would like to fly  
A rocket\_\_\_\_\_ on its mission.!

Now, Blue Jay\_\_\_\_ friendly Robin \_\_\_\_\_,  
And Oriole\_\_\_\_\_ and Thrush \_\_\_\_\_  
Said "Woody\_\_\_\_\_, Why be eager  
to leave earth in such a rush?

But Woody\_\_\_\_\_ had ambition,  
And though Blue Jay\_\_\_\_\_ persisted,  
The urge to see the space world  
Just could not be resisted.

Now Woody\_\_\_\_\_ took a fancy  
to the rocket 'Flying Star"  
And decided he would join it  
On its journey out toward Mars.

The mourning of the launching  
Dawned clear and cool and bright.  
Young Woody\_\_\_\_\_ was excited.  
He had hardly slept all night!

Blue Jay\_\_\_\_\_ was there, and so was  
Thrush \_\_\_\_\_  
Though Oriole\_\_\_\_\_ was slow,

And all of them still did their best  
To persuade him not to go.

But nonetheless the countdown came:  
5-4-3-2-and one!  
The rocket \_\_\_\_\_ came to life and Vroom!  
The launching had been done.

Blue Jay \_\_\_\_\_ and Thrush \_\_\_\_\_ and  
Oriole \_\_\_\_\_  
And Robin \_\_\_\_\_ strained to hear  
The throbbing of the rocket \_\_\_\_\_  
Which was no longer near.

Now came long hours of waiting,  
And Woody's \_\_\_\_\_ friends so stout  
stayed near the pad, they would be glad  
To greet him with a shout!

As evening shadows lengthened  
And night drew ever nigh,  
Blue Jay \_\_\_\_\_ said, "Hey!" and  
Thrush \_\_\_\_\_ said "Hush!"  
There's something high in the sky!"

And as they looked they could discern  
A tiny little figure.  
They watched and strained to catch a  
glimpse.  
Said Thrush \_\_\_\_\_ "It's getting bigger!"

Then suddenly there came a whoosh!  
And blazing light shone 'round.  
And when the friends could look to see,  
The rocket \_\_\_\_\_ was quite sound.

Thrush \_\_\_\_\_ held his breath, and  
Robin \_\_\_\_\_ gasped,  
And Blue Jay \_\_\_\_\_ made no sound.  
The rocket \_\_\_\_\_ made one last faint vroom!  
And Woody \_\_\_\_\_ bounded down!

Hail, Woody \_\_\_\_\_, first bird astronaut!  
Space tales, he had a score.  
Oriole \_\_\_\_\_, Blue Jay \_\_\_\_\_, Robin \_\_\_\_\_  
and Thrush \_\_\_\_\_

Kept begging, "Please tell just one more!"

So if you should see, one day in a tree  
A red-headed woodpecker \_\_\_\_\_ pecking,  
Just ask him to tell of his space trip and  
well...He'll talk in for hours, I reckon!

### The Whimsical Owl

Characters:                      What they say:

Pine Forest:	Sh-sh-sh
Cool gurgling brook:	Gurgle, gurgle
Whimsical owl:	Who-who
Serious squirrel:	Crack, crack
Hump:	Hump hump
Stump:	Stump, Stump

Narrator:  
By a **Cool Gurgling Brook** in the **Pine Forest**, sat a **Whimsical Owl** just watching and watching.

Along came his friend, **Serious Squirrel**, who said, "What are you watching, **Whimsical Owl** and why are you staying so long in that big tree by the **Gurgling Brook** in the **Pine Forest**?"

"I am watching a **Fearless Frog** who is caught in a **Hump** in the bottom of a **Stump** by the **Cool, Gurgling Brook** in; the **Pine Forest**," said the **Whimsical Owl**. "Hurry, scurry down and rescue him."

The **Serious Squirrel** said, "Shut your eyes and hoot up to ten and I'll have him out of there in no time." The **Fearless Frog** heard what he said and croaked, "Hurry up." While the **Whimsical Owl** hooted, the **Serious Squirrel** scampered down into the **Hump** of the **stump** and was soon at the bottom. The **Serious Squirrel** reached into the **Hump** in the **Stump**, as he would for an acorn and pulled the **Fearless Frog** out of the **Hump**.



"Hop on my back, **Fearless Frog** and I will give you a ride to the top of the **stump**," said the **Serious Squirrel**.

Just as the **Whimsical Owl** reached the tenth hoot, who should appear out of the **Hump** in the **Stump**, but the **Serious Squirrel** with the **Fearless Frog**. "Three cheers for you. **Serious Squirrel**," said the **Whimsical Owl**, as the **Fearless Frog** hopped off the **Serious Squirrel's** back and headed for the home in the **Cool Gurgling Brook**.

As the **Serious Squirrel** scampered off through the **Pine Forest**, the **Whimsical Owl** went back the his watching. Wasn't it lucky for the **Fearless Frog** that the **Whimsical Owl** was watching that day?

### SKITS (Requiring No Rehearsal)

For an audience participation show, let each child on stage read one of the following verses. Each described a bird common to a large part of the United States. The audience can call out the name as soon as someone guesses it.

Before the spring has time to wake  
The daffodils so yellow,  
My black and russet red appears-  
I'm quite a cheerful fellow.  
**(Robin)**

I make a sound like tinkling bells  
Or raise my crest and scold;  
My blur coat's trimmed with black and white  
I'm a handsome robber bold.  
**(Blue Jay)**

My family lives with others  
In houses built by you;  
How beautiful my swallow's flight  
My feathers' royal hue!

### **(Purple Martin)**

Demurely dressed in gray and white  
My nature's full of fun;  
I live to tease my feathered friends  
And mimic them one by one.

### **(Mockingbird)**

Though I am black, upon each wing,  
A spot of color shows;  
You'll find me near the marshes,  
Where'er the cat tail grows.

### **(Red Winged Blackbird)**

I wake you in the morning,  
As I call across the field;  
And when I fly, on yellow breast,  
A dark new moon's revealed.

### **(Meadowlark)**

At times I raid the orchard trees  
For fruit I love to eat;  
My nest swings gently in the breeze,  
My coat's a Halloween treat.

### **(Baltimore Oriole)**

My cousins chirp in city streets,  
But I dislike the town;  
In spring you hear me sing, and see  
My dark-streaked breast, with  
spots of brown.

### **(Song Sparrow)**

My tail points up, I sing with glee,  
I twitch with energy;  
Small, brown, and busy as a bee,  
I'll have you know that's me.

### **(House Wren)**

Because I like the sprouting corn,  
Popularity I lack;  
The farmer hates my croaking call,  
And my feathers large and black.

### **(Common Crow)**

I hide among the shrubbery

My spice-brown colored coat,  
And praise my evening song  
That springs from spotted throat.

**(Wood Thrush)**

My name suggests great dignity,  
My colors the brightest hue,  
In summer or in winter,  
I bring Christmas red to you.

**(Cardinal)**

Part of my name is palest brown,  
But you'll see, as I fly by,  
A streak of brilliant red and coal,  
Outlined against the sky.

**(Scarlet Tanager)**

Rat-tat-tat; Rat-tat-tat-  
I beat a loud tattoo.  
My back is black, my front is white,  
My red cap's in full view.

**(Red-Headed Woodpecker)**

For me, no cage inside the house,  
As I dart fro and back;  
I wear the tint of precious ore,  
Smartly trimmed with black.

**(Goldfinch)**

Where'er I go, I'm thought to bring  
Extra happiness.  
Blue wings for sky, Brown breast  
for earth,  
The children love me best.

**(Bluebird)**

JULY

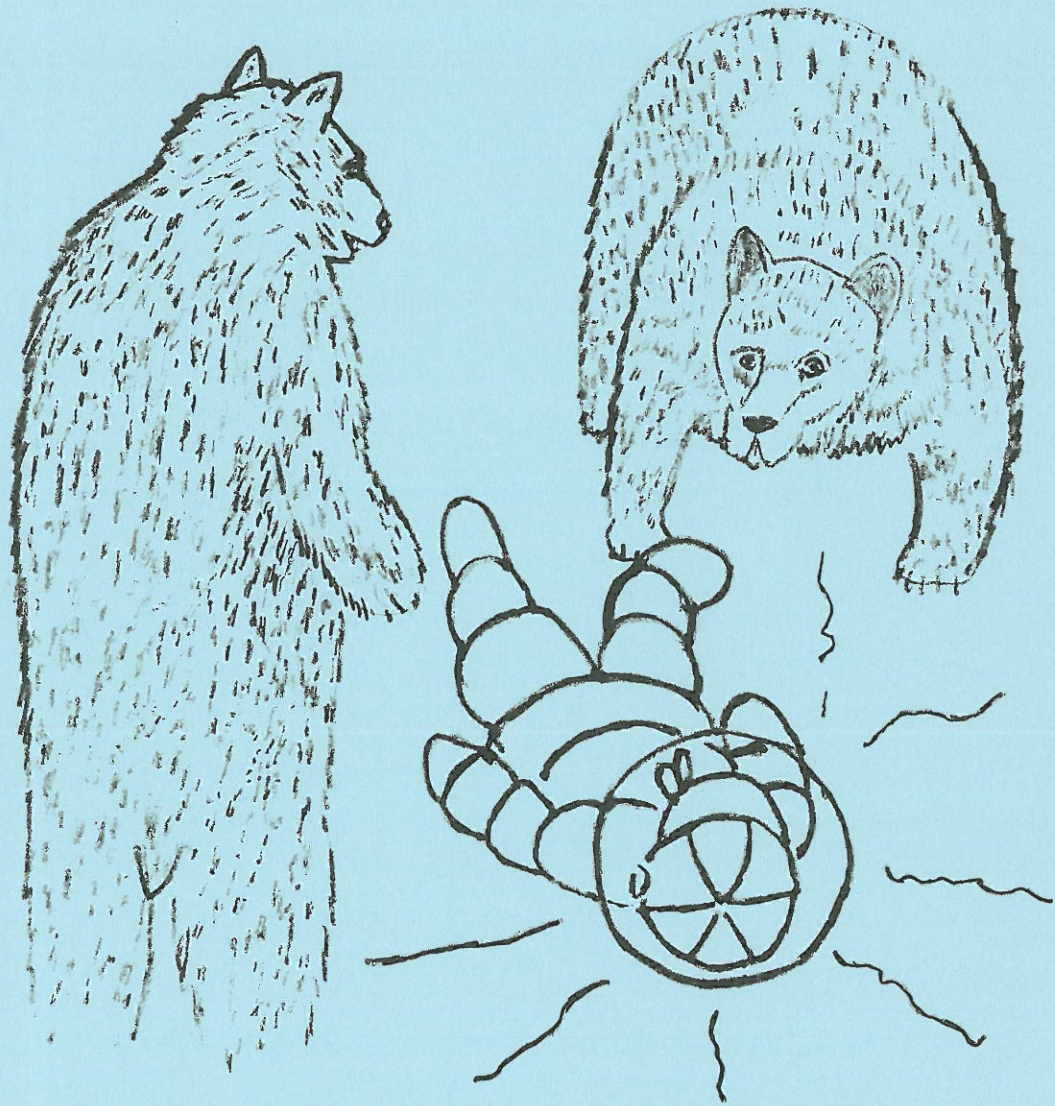

WILD AND  
WOOLLEY WEST



## WILD AND WOOLLY WEST

### GAMES

#### Donkey Kick

A small, flat piece of wood or a stick is used for this game. A player holds his leg up with the bottom of his foot held in back. The game leader then balances the stick on the upturned sole of the player's shoe. The player now kicks back with his foot and sails the stick as far from his back as possible. The longest kick wins.

#### Button Your Vest (Trick game)

Run a relay race with old vests. The players must do exactly as they are told. These are the instructions: "Put the vest on button it up, unbutton the vest, take the vest off, and pass it on the next person in line." Score one point for each person who buttons from the bottom to the top. (Button it **up** were the instructions) Team with most points wins.

#### Shooting From The Hip

This game promotes team work, cooperation, skill, and uncontrollable laughter from the observers.

##### Equipment Needed:

- One pair of old panty hose for each player
- One balloon for every two players
- One orange for every two players

Divide all the participants into teams of two. Have each person tie one leg of a panty hose around their waist and let the other leg hang the their side. In each team, one person drops an orange into the panty hose leg that

is not tied around the waist. The other team member ties his extra hanging panty hose leg above the orange of the first player so that the orange hangs between them. It should be long enough to hang down somewhere between the knee and the ankle. Inflate the balloons and place on the starting line in front of the hanging oranges. Mark a finish line about ten to fifteen feet away.



Upon the "GO" signal, each team swings their hips in unison to make the orange swing and hit the balloon. They quickly continue swinging their orange, with no hands allowed, moving the balloon across the floor toward the finish line. The first team to hit their balloon across the finish line wins. (Helpful Hint) This game is best conducted away from air currents that might blow the balloons around.

#### Tube Toss

Hey partner! Lasso yourself a steak!(stake)

##### Equipment Needed:

- One stake approximately three feet long
- One inner tube
- Fifteen foot long rope

Set the stake in the ground ten feet from the throwing line. Tie the rope securely to the

inner tube. Tie a small loop in the other end of the rope to place around the players wrist to he will not lose the rope as he throws the tube.

Give each participant three attempts to throw the tube and lasso the stake. The one that lassoes the stake the most times is the winner.

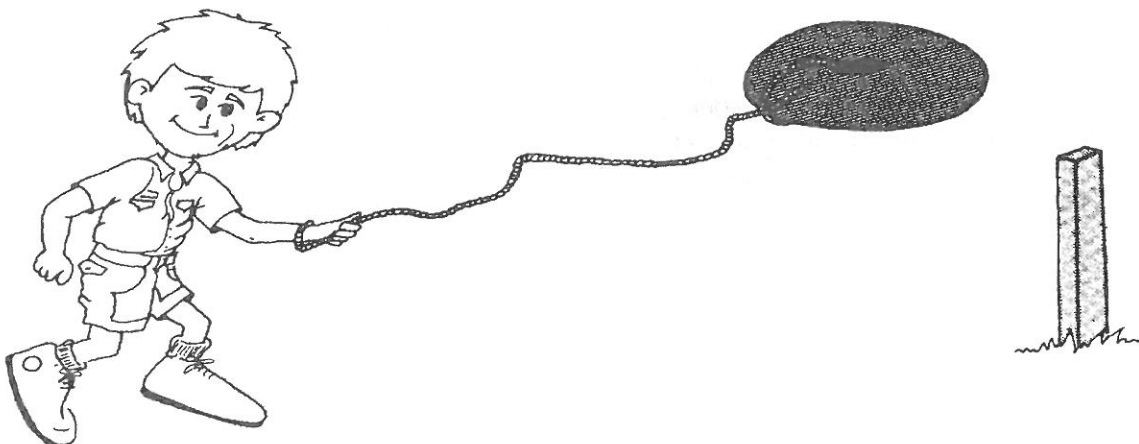

**Backwards Relay**

This game promotes agility, dexterity, and confusion.

Equipment Needed:

One four foot long nylon rope per relay team

it is correct at which time they give the rope back to the referee and run back and tag the next player. Play continues until each has tied a "backwards knot". This is not as easy as it sounds!

**Distance Throw**

A game of strength, accuracy, and patience!

Equipment Needed:

One, 1/4 inch by fifty foot rope.

Five markers

Five stakes

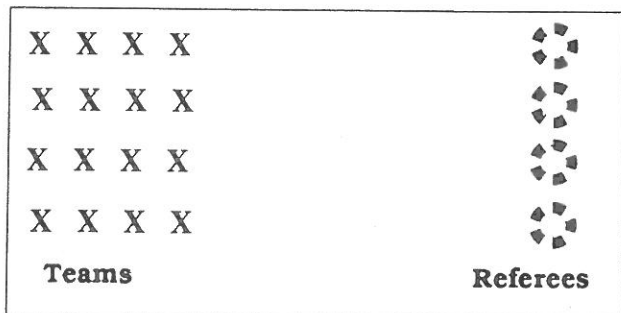

Divide into teams and assign a referee for each team. Line up as shown above. One at a time participants run to the referee where they are given the rope. They then turn their back to the referee and tie a square knot **behind their back**. The referee verifies that

Mark throw line then measure and mark distances of ten, twenty, thirty, forty, and fifty feet. Using a slip knot, put a small loop in the end of a fifty foot rope to put around the players hand. Have them coil the rope in the other hand. Each person throws the rope to see how far it will go. They cannot let go of the loop at the end. Each participant has three tries and then chooses his best throw.

(Helpful Hint) If you hold the middle of the rope coiled in one hand and other half coiled in the other hand, the weight of the first coil will slowly uncoil the other half. This will make the rope go farther.

### CRAFTS

#### LARIAT AND BRANDING IRON TIE SLIDE

Materials Needed:

- 1 1/2"x 2" piece of masonite or heavy cardboard
- 10" piece of twine or light weight macramé cord
- Black pipe cleaner
- Vinyl or pipe cleaner

Make lariat from 10" piece of twine or macramé cord and coil. Use pipe cleaner to form branding iron. Glue both lariat and iron to masonite, Glue vinyl or pipe cleaner to back side for slide.

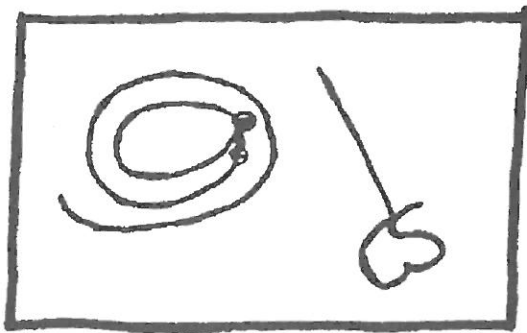

### One Shooter

Any boy would enjoy testing his accuracy in hitting a target with this rubber band gun. For Cub Scouts the guns should be cut out - Make the finger hole with a large drill bit - and the boys can do the sanding and attach the clothespin. The clothespin must be taken apart so the lower half can be nailed to the gun with small nails for better stability. 3/4" scrap wood is needed to make the gun. A heavy cardboard box is a good target.

ONE SHOOTER TEMPLATE

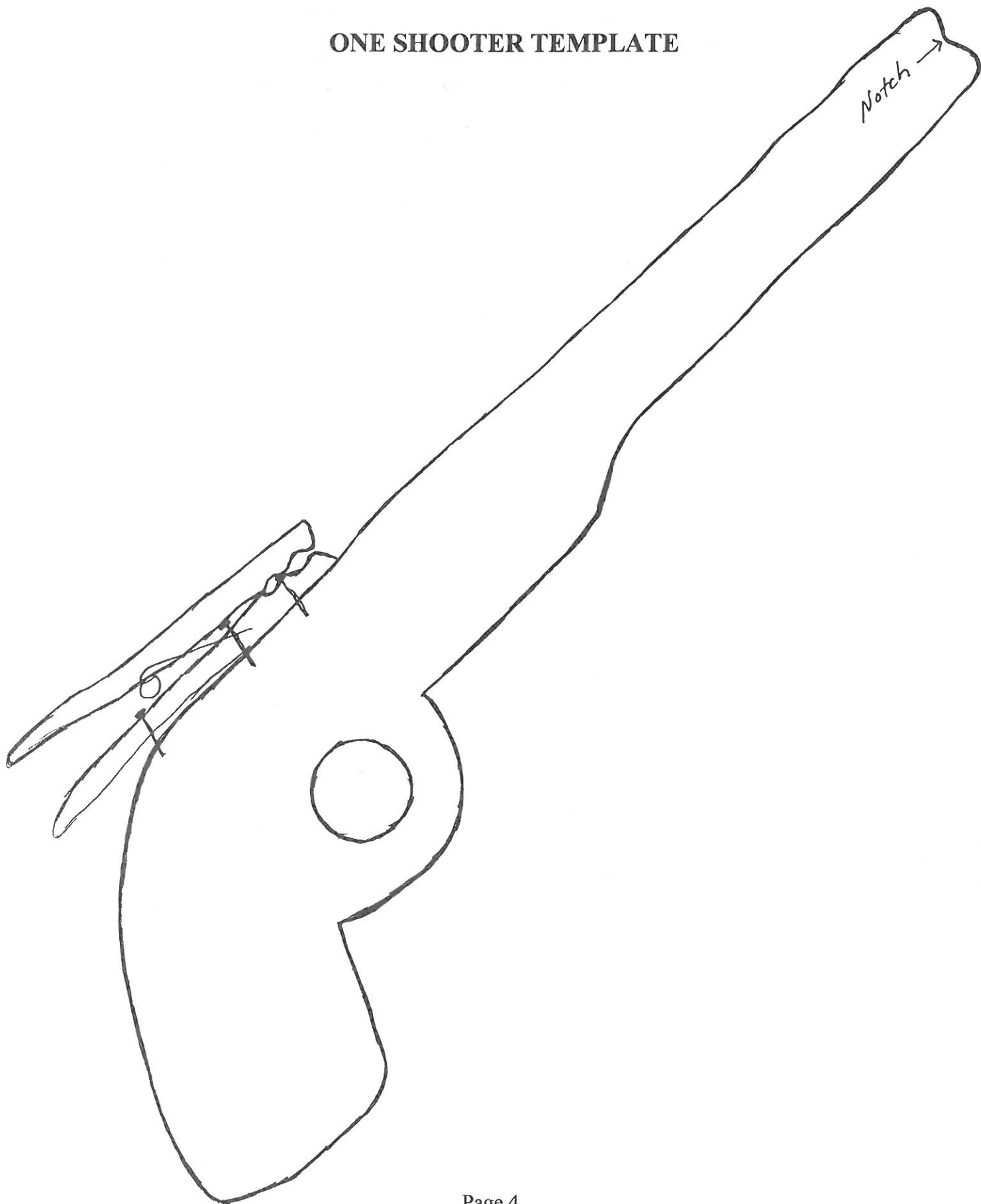



### Indian Head Tie Slide

For an Indian head neckerchief slide or lapel pin, cut a piece of corn cob 1 1/2" long. Glue braided yarn across top for hair. Glue on seeds, paper or pieces of cob for features. Glue on a headband made of a string of tiny beads or plastic lacing. Insert feather. Attach a curtain ring to back.



### SONGS

#### Old Akela Had A Pack

1. Old Akela had a pack, E-I-E-I-O.  
And in this pack he had some dens,  
E-I-E-I-O.  
With a Den 1 here, and a Den 2 there:  
Here a den, There a den,  
Every where a happy den.  
Old Akela had a pack, E-I-E-I-O.
2. And for these dens he had some chiefs,  
E-I-E-I-O.  
(With a den chief here , and a den chief  
there...)

3. And in these dens he had some Cubs,  
E-I-E-I-O.  
(With a Cub Scout here, and a Cub Scout  
There...)

4. And for these dens he had Leaders,  
E-I-E-I-O.  
(With a leader here and a leader there)

5. And for these dens he had parents.  
E-I-E-I-O.  
With parents here and parents there:  
Everywhere are happy parents,  
With leaders here and leaders there  
Here a Leader, there a Leader  
Everywhere are happy leaders...  
With a Cub Scout here, and a Cub Scout  
there: Here a Scout, there a Scout  
Every where a Cub Scout...  
With a den chief here and a den chief there,  
Here a chief, there a chief,  
Everywhere a den chief...  
With a Den 1 here, and a Den 2 there,  
Here a den, there a den,  
Every where a happy den:  
Old Akela had a pack, E-I-E-I-O.

### SKITS

#### Out Where Men Are Men

Assign the following characters to different Cub Scouts or dens, or you can divide the audience at a Pack Meeting. Then read the story. As each character is mentioned, the proper Cub Scout or group arises, Makes the appropriate sounds and sits down.

- |                   |   |
|-------------------|---|
| Cowboy:           | Raises right fist, yells<br>YIPPEE!   |
| Horse:            | Hits knees with hands   |
| Chief Red Jacket: | Taps palm on lips and<br>says KIYI, then puts<br>and over brow and<br>peers all around. |

Mule: Hee-Haw  
 Rattlesnake: Scratch pencil point on paper.  
 Timber Wolf: Wolf Whistle  
 Sheriff: Bang, Bang, Your dead!  
 Deputy Sheriff: "He went that-a-way".  
 Points in two directions.

Once upon a time, there was a **cowboy** who went riding his **horse** on the Mojave Desert. Far off in the distance he could hear the **timber wolf**. The **cowboy** made camp and went fast asleep, first making sure he secured his **horse**.

Now creeping along through the desert came **Chief Red Jacket** riding his **mule**, Sitting Bull. He was pursued by the **sheriff** and his **deputy**. In his pocket **Chief Red Jacket** had a trained **rattlesnake** whose name was Emma. This **Rattlesnake** Emma was trained to creep up and bite the **cowboy** and his **horse**. While **Chief Red Jacket** crept up, the **horse** was afraid, the **timber wolf** howled, the **cowboy** snored, and Sitting bull, the **mule**, was eating cactus.

Meanwhile, the **sheriff** and his **deputy sheriff** were almost ready to capture old **chief Red Jacket**, Just as Emma the **rattlesnake**, was about to bite the **cowboy** and his **horse**, the **sheriff** and his **deputy sheriff**, the **cowboy** woke up and mounted his **horse**. This frightened the **timber wolf** and also Emma, the **rattlesnake**. Away went old **Chief Red Jacket** on his faithful **mule**, Sitting bull, and away went, in pursuit, the **sheriff**, his **deputy sheriff**, the **cowboy**, and his **horse**. But old **Chief Red Jacket** led them into a blind canyon, so that was the last anybody ever saw of the **cowboy**, his **horse**, Emma the **rattlesnake**, the **timber wolf**, Sitting bull the **mule**. the **sheriff**, and the **deputy sheriff**. That's all folks.

### Opening

Four boys in Indian costume, carrying artificial torches. Artificial campfire which can be lit by connecting an electrical cord. Light bulb is inside campfire and covered with red cellophane.

Den Chief: (Dressed as an Indian Chief)  
 "Let the north wind enter."

(One of the boys enters carrying touch. He stands by campfire and says his lines. Others do likewise as they are called in.)

North Wind: "The North Wind that brings the cold, builds endurance."

Den Chief: "South Wind, enter."

South Wind: "The South Wind brings the warmth of friendship."

Den Chief: "East Wind, enter."

East Wind: "The East Wind brings the light of day."

Den Chief: "West Wind, enter."

West Wind "West Wind from the direction where the sun sinks, brings night and stars."

Den Chief: "The four winds will light our council fire."

(All four boys touch their artificial torches to fire at the same time. At this moment, electrical cord is connected off sage.)

To accommodate eight boys it the opening, two boys could come in at a time and speak together as one for each wind, of the Den Chief's part could be done by Cubs.

### The Sad Tale Of Two Famous Cowboys

Wild Bill Hiccup: "Hic-c-up"

Hap-A-Long Catastrophe: "Ooophs

Cactus: "ouch

Let me tell you the story of two famous cowboys from Western history. Yea, you've guessed it! They are **Wild Bill Hiccup** and his sidekick, **Hap-a-long Catastrophe**. It seems that **Wild Bill Hiccup** was constantly plagued with long seizures of hiccups for which there seemed to be no cure. Many doctors all over the land of sagebrush and **cactus** had tried to cure him, but it was all in vain. Nothing worked!

**Wild Bill Hiccup** had a sidekick, **Hap-a-long Catastrophe** who was also plagued with a peculiar ailment. It seemed that he was so clumsy that he was like a bull in a china shop. He stumbled his way from one catastrophe to another.

Out in this land of sagebrush and **cactus** these two men were continually keeping each other company and trying to keep out of the way of others so as not to disturb any more people than necessary. Thus **Wild Bill Hiccup** and **Hap-a-long Catastrophe** were together constantly.

One day, as usual, **Hap-a-long Catastrophe** stumbled and fell while trying to mount his horse, thus scared the horse and caused him to run away. Being his best friend and feeling sorry for his constant bad luck, **Wild Bill Hiccup** told him to jump onto his horse and they would ride out through the **cactus** and look for the runaway horse.

Finally, with much effort and many tries to stay on, **Hap-a-long Catastrophe** made it onto the horse with **Wild Bill Hiccup** and off the two rode through the land of sagebrush and **cactus**. After riding a while

they caught sight of the horse. It had calmed down and was slowly walking among the **cactus**. Wouldn't you know it! **Wild Bill Hiccup** got so excited at finding the horse that he began to hiccup violently and of course, **Hap-a-long Catastrophe** being the way he was could not take the jerking of his friend on the horse. Just as they came to the next big cactus **Wild Bill Hiccup** gave out with a tremendous hiccup which sent **Hap-a-long Catastrophe** sprawling right into the middle of the **cactus** and frightened the horse again and sent him running off into the sunset.

The last we saw of our Western heroes, **Hap-a-long Catastrophe** was still trying to mount **Wild Bill Hiccup's** horse, only to be sent flying back into the **cactus** by a giant hiccup from his friend. I'm sure after so many trials and failures, our heroes must have felt the whole thing was pointless, but the **cactus** was still there reminding them of the point.



# AUGUST



# CAMPFIRE YARNS



## CAMPFIRE YARNS

### GAMES

#### Spinning A Yarn

A long (several yards) piece of yarn with knots tied randomly along the length is needed. Some knots should be close, others far apart. The object is to have a group of people make up a story after the leader has given them a theme. Each person talks while winding the yarn around a ruler until they reach a knot, then the next person continues the story.

#### Hoop and Spear

Use a basket hoop or make one 12 inches in diameter or larger out of a pliable stick bent to form a hoop. Make a spear 5 feet long and 3/4 to 1 inch in diameter. The game consists of rolling the hoop on the ground and players taking turns at throwing the spear at the moving hoop to stop it and get points, according to where the hoop color and spear color touch. Red counts 10 points, Yellow 4, Blue 3, Green 1. Make sure that all players are on the same side of the hoop.

#### Indian Giveaway (Commanche)

Boys stand in a circle with the leader (Chief) standing just outside the circle. The chief throws small sticks (Pop sickle sticks) one at a time into the circle. Each stick represents an Indian blanket. The first boy to recover the stick after it touches the ground gets it as his prize. This game teaches young braves to be alert and fast.

### Feather Race

The quill ends of feathers are stuck lightly into the ground. The contesting braves line up behind a starting line and on the word "GO", each races to his feather and without kneeling, plucks his feather from the ground by using his teeth, and races back to the starting line with it. If played indoors, place feathers between two boards.

### CRAFTS

#### Log Cabin Bank

##### Materials Needed:

- 42 - Pop sickle sticks
- 1/2" plywood or clipboard for ends
- Small ceramic tiles or foil for windows and doors
- Glue
- Varnish

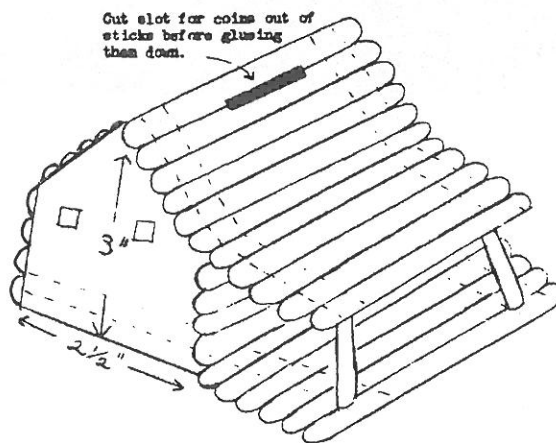

#### Slapstick Star Burst Mat

Drill hole in slapsticks. Or buy sticks with holes already drilled. Each stick has two holes, one at the end and one in the middle. You will need 1 yard of elastic thread on

which to thread the sticks. You will also need 33 small wood beads and 33 slapsticks. Plus dye or paint if you wish to color your Sunburst Mat.

Thread Slapsticks. Using a needle or just your hands, thread the elastic through all "end" holes in the sticks. Pull snug. Tie a knot and cut off the excess elastic. Follow the same procedure for the middle holes but alternate beads between each stick so that your mat will look like the finished illustration. Pull the elastic snug (not too tightly of your mat will buckle).

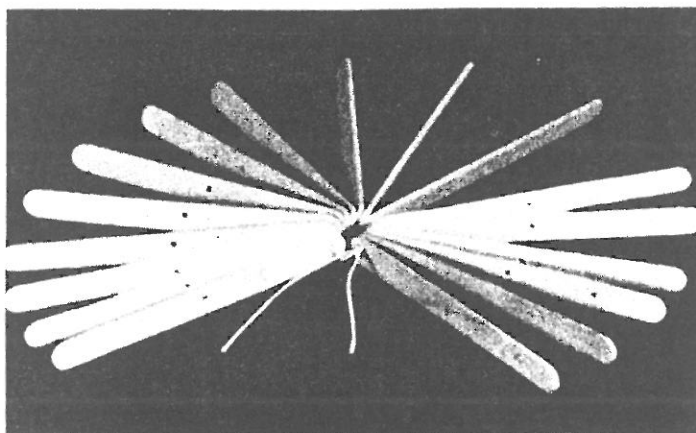
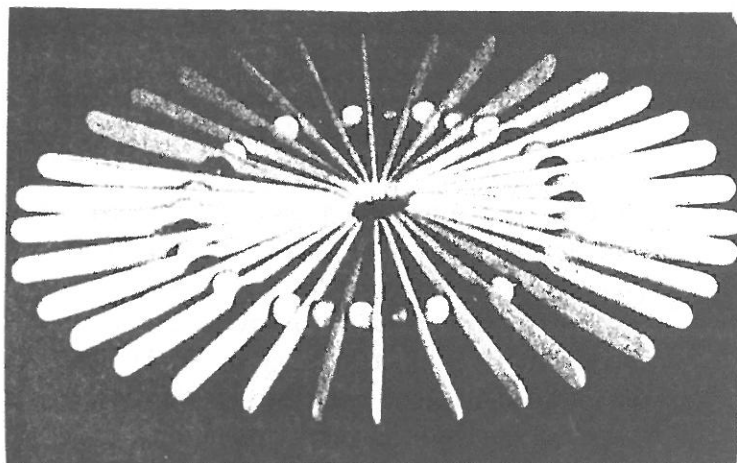

Tie a knot in the elastic. Cut off the excess elastic and your Sunburst Mat is complete, unless you wish to dye or paint it. The fastest way is to dye the mat by dipping it in a deep-dish of dye, any color you wish. If you desire a multicolored Sunburst Mat, it is necessary to complete the coloring process prior to assembly. They can also be spray painted or splatter painted.

## SKITS

### Three Rivers

Equipment needed:

A campfire

A large kettle

Plates and spoons for each Cub Scouts (stacked by the fire)

People:

A cook

Several Cub Scouts

A dog (Cub Scout on all fours)

Cook is stirring the kettle over the campfire. The first Cub Scout walks in.

Cook: "Howdy Pardner"

Scout: "That sure smells good."

Cook: "Care to have some?"

Scout: "Sure." He picks up a plate and spoon and asks: "Is this plate clean?"

Cook: "As clean as Three Rivers can make it."



Reassured, the Scout lets the cook give him a pretend ladle full of stew; steps to the side; and pretends to eat.

(Repeat for as many Scouts as you have.)

After everybody is finished and the plated are handed back the cook with a "Thank you."

Cook: "Here, Three Rivers! Here boy! Come and clean up the dishes!"

The last Cub Scout comes on all fours and pretends to lick the plates. All the other Cubs stick out their tongues and look sick.

### The Tox Without A Fail

Once upon a long long time ago, an old fag grox tail into a frap, and had a diffy vercult time exing to tryacate himself. Finally he did so, but during the process, the goor pie tossed his lail.

This made him merry, merry vad indeed, and he girured he would never div it lown unless he could perfox the other suades to tart with their pails too!

So he mawled a keeting of all the further oxes, and advised them to tut off their kails. "They are very thugly ing anyway," he said, "and it's a tight quiresone to have them always ricking out in the stear, dathering gust."

Bust one of ther folder oxes said, "My dear dend, if you hadn't tossed your own lail, you wouldn't dee so bean on getting us to tooze ours, loo!" And the storl to this mory is: Destiny apes our shends, so why get 'em caught in a tox fap?

### Fire Safety, Graveyard Skit

Two tables are laid on their sides with the tops facing the audience. The tombstones with Epitaphs are mounted on the tables. Each Cub, with his puppet, is out of sight behind the table.

Character: Cigarette Sid  
Epitaph: Cigarette Sid  
Smoked in bed, he did!  
Part: I smoked and smoked and smoked in bed, And now you see that I am dead.

Character: Wire Willy  
Epitaph: Wire Willy  
He was so silly  
Part: I played with frayed wire, I thought it okay. I became a spook without delay.

Character: Ruthie Rags  
Epitaph: Ruthie Rags  
To dust she has returned  
Part: I saved oily rags to use again. No telling when it might have been.

Character: Campfire Kurt  
Epitaph: Here lies Campfire Kurt  
the careless camper  
Part: We thought the campfire was under control.

Character: Gertie Grease  
Epitaph: Gertie Grease  
Rest in Peace  
Part: While in a hurry the hot grease splattered! I didn't know it really mattered.

Character: Matches Mike  
Epitaph: Matches Mike  
He played with fire!

Part: I played with matches-- it was such fun! 'Till I caught on fire and began to run.

Character: Lawnmower Lonnie

Epitaph: Lawnmower Lonnie  
He is no "mow"

Part: I filled with gas the lawnmower hot. So like the others, now I'm not.

Character: Dennis Door

Epitaph: Poor Dennis...  
A blocked door was a menace

Part: The outside door was blocked by a chair. I wanted out, but I couldn't get there.

Character: Charcoal Charlie

Epitaph: Sorry, Charlie!  
Not only the food turned to charcoal

Part: I threw lighter fluid on hot charcoal. Whoosh! The fire was out of control.

a string of **Fish**. "My said the **Bear** admiring the **Fish**. "Where did you get such beautiful **Fish**?" "In the river by the **Forest**," replied the **Fox**. Why didn't the **Bear** go down through the **Forest** to the river and catch some **Fish** for his dinner?

The **Bear** was hungry and he wanted some **Fish**. What's the best way to catch the **Fish**, the **Bear** asked the **Fox**. Go down through the **forest** to the river and cut a hole in the ice Then put your tail in the hole and wait for the **Fish** to bite. The more beautiful the tail , the more **Fish** you will catch, said the **Fox**. When the **Fish** bite, it may sting and hurt a bit but you must sit there as long as you can. The longer you sit the more **Fish** you will catch, The **Fox** told the **Bear**. When you think you have caught enough, pull out your tail. Just give a hard and strong pull, Now remember all I've told you, said the **Fox** to the **Bear**.

Now the **Bear** knew he had the most beautiful tail in the **forest** and it wouldn't take long to catch those **fish**.

### Why The Bear Is Stumpy Tailed

Characters: What They Say:

Fox: Snicker, Snicker

Bear: Growl!!

Fish: Yum, Yum!

Forest: All sounds together

Once upon a time, many years ago, a very big **bear** lived in the **forest**. This **bear** had a beautiful tail, the most beautiful tail in the **forest**. He was always bragging about his beautiful tail. All the other animals in the **forest** decided something had to be done to teach that **bear** a lesson. The **fox** came forward and said he had a plan.

So one winter afternoon, the **Bear** met the **Fox** coming through the **Forest**. The **fox** had

The **Bear** went through the **Forest** to the river and cut the hole and sat so his tail hung down in the water. It got colder and colder and after awhile his tail began to sting and hurt, but the **Bear** remembered what the **Fox** said. It kept on stinging and hurting but the **Bear** didn't get up because he believed the **Fish** were biting, just as the **Fox** had told him.

Late afternoon, as the sun started down in the **Forest**, the **Bear** thought he had enough **Fish**. The **Bear** tried to stand up and pull out the **fish** he had caught. But he couldn't stand up straight. The water in the hole had turned to ice and frozen solid. The part of his tail in the river by the **forest**, was stuck. The **Bear** was getting angry, but he remembered what

the **Fox** had told him. So he pulled and pulled and pulled. All of a sudden, the **Bear's** tail came out of the ice...but only part of it, his beautiful tail was gone

To this day the **bear** has a stumpy tail!



# SEPTEMBER



# AMERICAN FOLKLORE



## AMERICAN FOLKLORE

## Unicorn

## GAMES

## Indian Dirt Ball

## Equipment Needed:

Tennis Ball  
Broom stick for each Cub Scout  
2 Boxes for goals

Divide Cub Scouts into 2 teams. Place ball in the middle of the playing area, On the sound of the whistle each team will try to maneuver the ball to their goal to earn points (usually 1 point per goal) while the other team tries to steal the ball and make a goal of their own.

The ball cannot be batted across the playing area. It must be rolled across the floor to the goal.

**Strict rules are needed for this on the handling of the broom sticks.**

As a substitute for broom sticks use wooden yard sticks or rolled up newspaper.

## Siamese Twins Race

This is a race. A pair of players stand back to back with a broom stick between their legs, and their hands on the end of the stick. They then race from the starting point and back. They must hold onto the stick, one goes forward, and the other goes backward. the turning point is where they change direction and return. They do not turn , but stop and reverse direction. Thus a player goes backward one direction and forward the other.

## Equipment Needed:

2 - baseball caps  
2 - 10 inch dowels  
Tape  
String  
Paper clips  
Canning jar rings  
2 - safety goggles  
2 - brooms  
Rope

Preparation: Tie the rope overhead in a manner that will allow you to hang the canning jar rings as shown in the illustration. Tie different lengths of string to the length of rope. Open paper clips as shown and tie them to the opposite ends of the string. Hang canning ring on the paper clips. Tape the dowel to the top of the hat bill as shown.

Player puts on their safety goggles, unicorn hat, and mount the broom like a stick horse. He is now the unicorn. The object of the game is to ride through the rings, spearing as many as possible in a 15 second time period. rings must stay in the dowel to count as points. The player spearing the most rings in the time period wins.

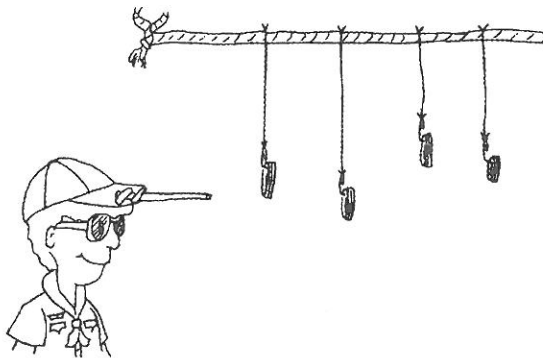

## CRAFTS

## Corn Cob Donkey

## Materials Needed:

- 1 - medium-size corn cob
- Corn silk
- 1 - Corn husk
- 4 - pieces of wood dowels or sticks 1/4" round, 2" long
- Small kitchen knife
- Glue
- 2 - Peppercorns

Scrape off all corn kernels with a knife. With the knife, cut the corn cob into 3 pieces; about 1 1/4" of the tapered end for the head, 1 1/4" for the neck and the rest of the cob for the body. It is easier to cut through the cob while it is still soft; then let the pieces dry for about a week.

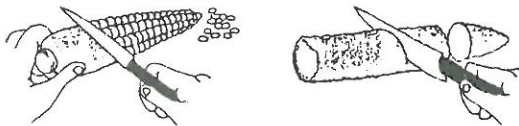

Cut dowel or stick into 4 - 2" pieces. Put a small amount of glue on one end of a piece of the stick and place it on the bottom of the body, at the back. Push it firmly into a kernel hole. Do the same for the other back leg. Place the other 2 legs at the front of the bottom. Put the body on the table and see if the legs stand. Let glue dry in standing position. Glue neck part on top of the front of the body in an upright position.

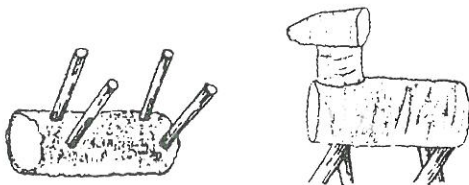

Glue the head to the neck with the tapered end facing front. Wait for glue to dry. Put

glue on back of head and lower part of neck and put on as much corn silk as you can. Let glue dry, trim mane. Glue silk onto end of donkey. Let dry and trim tail.

Cut a 1 1/2" square piece from corn husk for saddle. Glue on top of body. Cut 2 pieces of husk, tapered at both ends, for the ears. Glue onto head. Glue in 2 peppercorn, one on each side of head, for eyes.



## SONGS

## The Legend Of Davy Crockett

Born on the mountain top in Tennessee,  
greenest state in the land on the free.  
Raised in the woods so he knew every tree  
kilt him a bar when he was only three.

## Chorus:

(A singin') Davy, Davy Crockett, king of the  
wild frontier. (Once again now...) Davy,  
Davy Crockett, king of the wild frontier.

Off thru the woods he's a marchin' along,  
makin' up yarns and a singin' a song.  
He's a itchin' for fightin' and a rightin' a  
wrong, he's a ringy as a bear and twice as  
strong.



Chorus:

(A singin') Davy, Davy Crockett, king of the wild frontier. (Let me hear you sing it...)  
Davy, Davy Crockett king of the wild frontier.

Went off to congress and served a spell,  
fixin' up the government and laws as well.  
Well he took over Washington so we heard  
tell, and patched up the crack in the liberty  
bell.

Chorus:

(A singin') Davy, Davy Crockett, king of the wild frontier. (Let's sing together now...)  
Davy, Davy Crockett, king of the wild frontier.

He heard of Houston and Austin and so,  
the Texas plains he just had to go.  
Where freedom was fighting another blow,  
and they needed him at the Alamo.

Chorus:

(A singin') Davy, Davy Crockett, king of the wild frontier. (Now let me hear you shout it...)  
Davy, Davy Crockett, king of the wild frontier.

His land is biggest, his land is best,  
from grassy plains to the mountain crest.  
He's ahead of us all a meeting the test,  
follow his legend fight into the west.

Chorus:

(A singin') Davy, Davy Crockett, king of the wild frontier. (Let me hear you shout it...)  
Davy, Davy Crockett, king of the wild frontier.

## SKITS

### The Pink Dragons

Characters:

Reader	
Puffy Dragon	I huff and puff
Mother Dragon	Cheese, please
Father Dragon	We need cheese
Brothers Three:	(1 <sup>st</sup> brother) I'm Muffy (2 <sup>nd</sup> brother) I'm Tuffy (3 <sup>rd</sup> brother) I'm Stuffy
	(All brothers rise in rapid succession.)
Cheese	Rats!
Moon	Brightly beaming

As the name of the individual character is mentioned, the person assigned to be that character rises and makes the sound indicated for that character.

Story:

**Puffy** was a dragon so rosy and pink. His **father** was pink as could be. His **mother** was pink, and what do you think? So were his **brothers three**.

Now dragons like **cheese**, Or didn't you know? And **Puff** was a dragon clear through. **Puff** dearly loved **cheese**, couldn't get enough **cheese**. His family felt the way too!

"Our **cheese** is all gone!" **Mother** cried out one night. Said **Father**, "That simply can't be!" "Oh yes," replied **Mother**. "If you don't believe it, Why you just take a look and you'll see!"

To the **three brothers** said **Puff**, "This is really rough. We simply can't do without **cheese**." The **three brothers** agreed; then to **Puff** they did plead, "Oh, what will we do? Tell us please!"

Now **Puff** had heard tales that the **moon** was all **cheese**, and this thought came to **Puff** now. "We'll go to the **moon**, we must get there soon. I wish I could jump like the cow!"

To **Father** and **Mother** and his pink **brothers three**, **Puff** excitedly told his plot. "Never fear," said his dad, "It's really not bad. We can fly there, believe it or not!"

So **Puff** and his family flew to the **moon**, and out of its side took a bite. "We can't take it home, it's too big," **Mother** said. "We'll have to come back every night."

If the big yellow **moon** at night you do see, grow smaller each eve slice by slice, You'll know that it's **Puff** and his pink family eating **cheese** from the **moon** and not mice.

### Legend Of Davy Crockett

Characters:

Announcer

6 Cub Scouts in Davy Crockett costumes

7<sup>th</sup> Cub in dress clothes and wearing a coonskin cap.

Announcer: Tonight we bring you the story of a famous American, Davy Crockett - A brave and powerful man. Raised in the woods of green Tennessee, he soon learned to know and name every tree.

1<sup>st</sup> Cub: He learned to know the critters, from the Possum to the Bear, Wait until you hear what he did with just a stare!

2<sup>nd</sup> Cub: He scared a coon right out of a tree with just a grin and a big old stare. He tried it on a bear, but the bear wouldn't scare, so he challenged him to a fist fight and won him fair and square.

3<sup>rd</sup> Cub A streak of lightning Davy mounted; all the stars he named and counted. He caught the tail of a passing comet, and put a piece of sunrise in his pocket.

4<sup>th</sup> Cub Davy was caught between a panther and a bear, so you see he couldn't use just a simple little stare. He aimed "Old Betsy" at a rock between the two - the bullet split that rock and left a trail of blazing blue. One piece of rock killed the panther, the other demolished the bear. A mighty combination "Old Betsy" and Davy's stare.

5<sup>th</sup> Cub Davy was a fighter honest, brave and true; but fighting, it was told to me, always made him blue. A treaty was signed. Davy helped make the peace. And in that land, fighting did cease.

6<sup>th</sup> Cub This is a fine country. It's worth fighting for. Guess I'll head for the fort called Alamo, where the Texans are fighting for liberty.

Announcer: Folks liked Davy's way of doing things. They thought Davy ought to be a congressman and help run the country. The critters seemed to think so too, Even the crickets all chirped, "Crockett for Congress! Crockett for Congress!" In the nation's capitol, Congressman Crockett made this speech:

7<sup>th</sup> Cub: I'm Davy Crockett, fresh from the backwoods. I'm half horse, half alligator, and a little bit tetchted with a snappin' turtle. I got the fastest horse, the prettiest sister, the surest rifle, and the ugliest dog in Tennessee.

(All boys sing "Davy Crockett")

### The 'Bodies'

Once upon a time there were four people named Everybody, Somebody, Nobody and Anybody. When there was an important job to be done, Everybody thought that Somebody would do it. Anybody could have done it, but Nobody did it.

When Nobody did it, Everybody got angry because it was Everybody's job. Everybody thought that Somebody would do it but Nobody realized that Nobody would do it.

So it ended up that Everybody blamed Somebody when Nobody did what Anybody could have done in the first place.

So keep this in mind when there is a job to be done and do it in the Cub Scout Spirit.

### The Pea Little Thrigs (Short story)

Once upon a time there lived an old punther mig and her sea thruns. One day she bold her toys they'd have to go out and feek their own sorchun, so the pea thrigs set out on their wepparare saize.

The purst little fig, turlkale, hadn't fawn very gar when he enmannered a nice looking count, carrying a strundle of yellow baw. "Meeze, Mr. Plan," pe the sig, "will you give me that haw the build me a straru?" The nam gace him the wundle, and the pittle lig kilt hinsmlt abretty pottage. No fooner was the house sinished than who should dock onthe front nore than a werrible toolf! "Pittle lig, pittle lig!" he said, "May I come in and hee your sitty proam!" "Thoa, thoa, a nozand times thoa!" pied the crig, "not by teh chair of my hinny-hin-hin!" "So the wolf said, "Then I'll bluff and I'll duff and I'll hoe your blouse down!" And he chuffed up his peeks, blew the smith to housareens, and sat down to dinner of roast sow and piggerkraut.

Spotty, the peckund sig, met a man barrying kundle of shreen grubbery. "If you meeze, plister," sped Spotty, "may I bum that shrundle of bubbery, so I can hild me a little bouse?" The man banded the hundle to the pappy hig, and Cotty built his spottage. But

no sooner had Setty got himself spottled than there came a sharp dap at the roat and someone in avie hoice said, "Pello, little higgly! I am a wendly froolf. May I liver your enting room?" "No, no, "pelled the yiggy; "not by the chin of my hairy-hair-hair!" "Very wise then, well guy, I'll howff and pawff and I'll how you blouse down." So the wolf took breveral deep seths and blew the shamzey house to flimbles, and the pat little fig became the doolf's winner.

The last little pig, Ruttle Lint, met a man with a brode of licks. The man brave him the gicks, and luntle rint built his cream dassle. Soon he verd a hoice: "Pittle lig, Pittle lig! Swing oden your poor and well me bidcome!" "Not by the hin of my cherry-chair-chair! And furthermore, you'll not hoe this blouse down because it's constricted of brucks!" The bloof woo and he woo. Then he glue aben. Meanwhile, the pig filt a roaring byer and put a bettle on to coil. "I can't let you in because my store is duck! Just chime down the climney." So the wolf rimed up the cloof and chimmed down the jumpeny right in the wot of boiling pawter. And for the next wee threeks the pappy little hig had wolf rarespibs, wolf tenderstain liokd and wolf's sow-and -feeter-kraut, all with puckle and misstard.



# OCTOBER

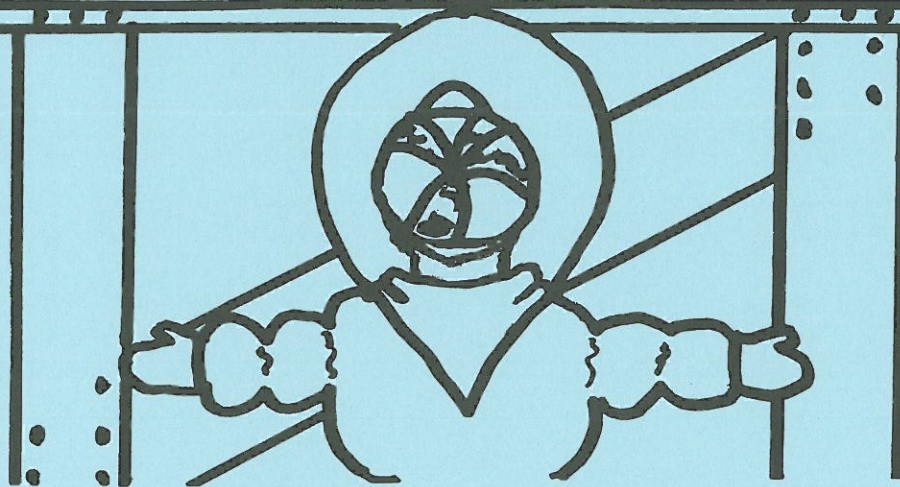
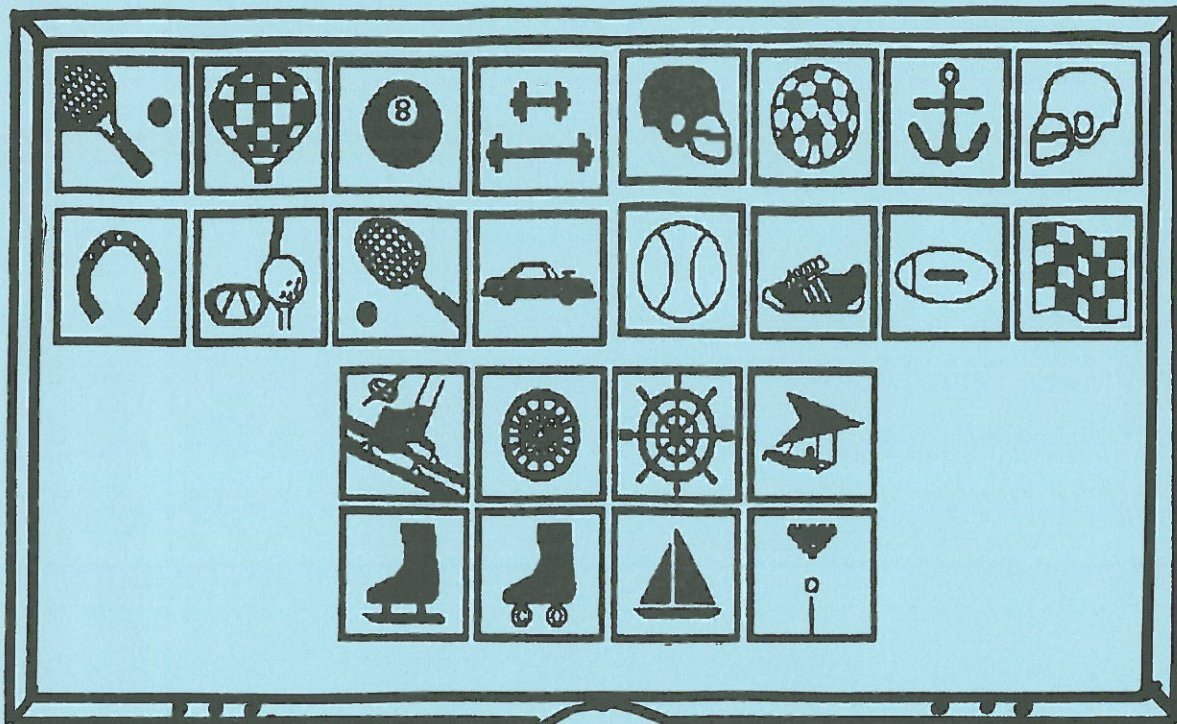

# FAMILY HOBBIES



**FAMILY HOBBIES****GAMES****Bets You Can't Lose**

Bet someone that he can't stand with his left foot and left shoulder touching the wall, then raise his right foot -- As easily demonstrated, this is a physical impossibility.

Bet you can drop an egg six feet through the air over a hard surface without breaking the egg. -- Drop the egg from a height of six feet, one inch. It will not break until after it's six-foot fall.

Bet your adversary that he can't take off his shoes and socks by himself. -- As soon as he begins taking off his shoes, you do the same with your own. Get it?

Place an empty soda bottle neck-end down on the center of a dollar bill. Bet that you can remove the bill without touching the bottle or making it fall over. -- Using two hands, carefully roll up one end of the dollar. When the rolled portion reaches the bottle, keep rolling-gently-to nudge the bottle off the bill without touching it.

**Matching Softball Terms**

1. An insect
2. Object which holds money or valuables
3. Mixture which is used to make pancakes
4. A big party
5. Bottom of an object

6. A method of moving from one place to another
7. Something that happens to nylon hose.
8. You can pour water from this
9. A gem or stone for a ring
10. A flying mammal
11. The way to light a match
12. Unmarried
13. A place to live
14. A type of dish
15. Nasty, unpleasant
16. Not at home
17. A piece of playground equipment
18. Chatter given by a sales person
19. A child's game
20. Opposite of outing
21. A mess of fish
22. Two shows in one night
23. To take illegally
24. A Boy's name
25. A best selling record

(Answers:)

Fly, safe, batter, ball, base, run of walk, run, pitcher, diamond, bat, strike, single, home, plate, foul, out, backstop or slide or swing,

pitch, tag, inning, catch, double header, steal, Homer, hit.

### Following Directions

On a piece of lined paper have the Cub Scouts number from 1 to 19. Duplicate the following and test the ability of your Cub Scouts in following directions.

1. If you ever saw a cow jump over the moon, write "V" in spaces 2,3,18,&19. If not, write "L" in these spaces.
2. If "X" comes before "H" in the alphabet, write "Z" in space 16. If it comes after "H" write "W".
3. If 31,467 is more than twelve dozen, write "G" in spaces 8 and 12.
4. If you like candy better than mosquitoes, indicate with an "O" in spaces 13 and 14. If not better consult a psychiatrist at once.
5. Closing one eye and without counting on your fingers, write the fifth letter of the alphabet in space 11.
6. If Shakespeare wrote "Twinkle Twinkle Little Star", put "O" in spaces 9 and 17. Otherwise "I".
7. If white and black are opposites, write "V" in space 10. If they are the same color write nothing.
8. If 16 quarts make 1 pint, draw an elephant in space 7. Otherwise write "S".

9. If summer is warmer than winter, put a "U" in space 5 and add an "A" in space 1.
10. If you think this is foolish, write the third, second, and fourth letters of the alphabet in spaces 4, 6, and 15 respectively. Now read the message - **It makes sense!**

### Parts Of Body Match-Up

1. Part of a wagon
2. A school child
3. Tropical trees
- 4.. Edge of saw
5. What a dog buries
6. A cad
7. A place of worship
8. Top of a hill
9. What you put to the wheel
10. What the tortoise raced with
11. Part of a river
12. Sometimes it locks
13. To keep tools in
14. A type of macaroni

(Answers:)

Tongue, pupil, palms, teeth, bones, heel, temple, crown, shoulder, hair, mouth, jaws chest, elbow.



### Butterfingers

Divide into two teams and give each team a pair of heavy gloves or mittens and a bag, containing a stick of wrapped gum for each member. On the signal, the first person puts on the gloves takes out a piece of gum and unwraps it, puts it into his mouth, and puts the wrapper and the gloves into the bag and hands it to the next player. Continue until all team members are chewing and the gloves and all wrappers are in the bag.

### The Bicycle Trail

#### Preparations:

*Glue the title, the instructions, and the map to a large piece of heavy cardboard or wood. Decorate the game and board with color if you wish*

*After the glue has thoroughly dried, coat the entire board with clear shellac or varnish to provide a hard finish.*

#### Instructions:

1. The object of this game for two or more players is to make a trip from "home" to the "park".
2. The rider who gets to the "park" first wins the game.
3. Each player uses a bean or small button for his marker.
4. All players start at the space marked "home". Players take turns.

5. To determine the number of spaces to move forward, a player holds a pencil (with the eraser end down) above the "bicycle wheel". Closing his eyes, the player circles the pencil above the wheel, then brings the pencil down until it touches the wheel. The number on which the pencil lands tells the number of spaces the player moves his marker. If the pencil lands outside the "bicycle wheel" or touches a line, the player tries again.
6. Two or more markers may occupy the same space.
7. A rider must not "speed" into the "Park", but must arrive there on an even count.

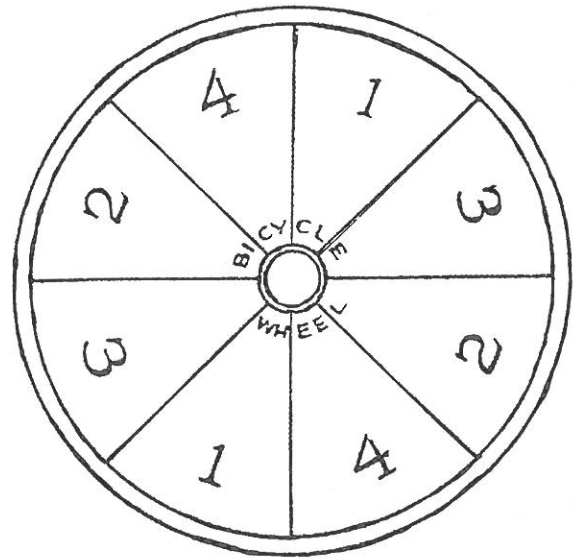

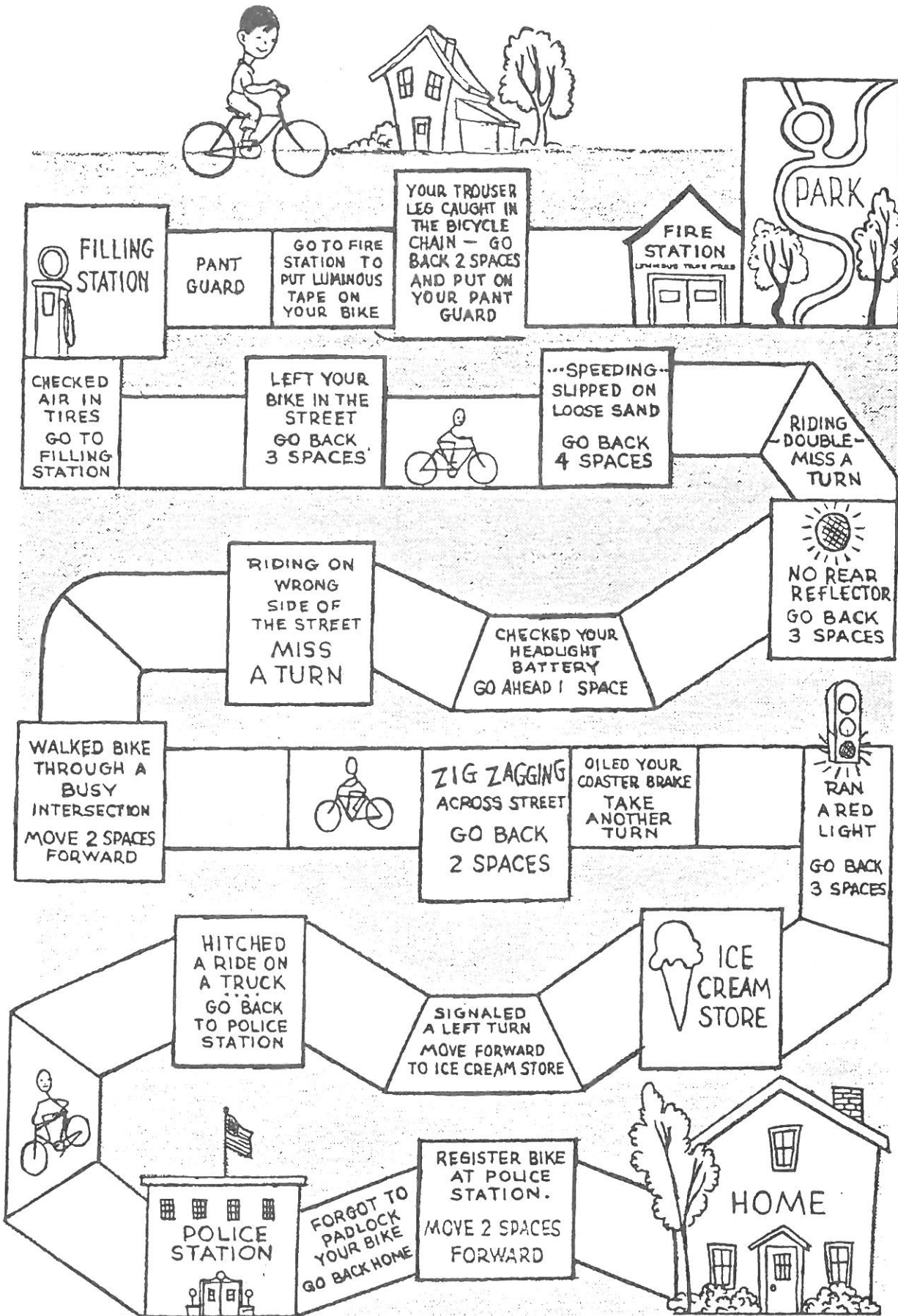

**Tangram**  
(An Ancient Chinese Puzzle)

How many shapes can you make using these few pieces? Color the pieces all one color. Paste them on thin cardboard and cut out when dry. See if you can put them together to make a square.

Assorted figures may also be made from these pieces. Let your Cubs use their imaginations!! This is a great gathering time activity.

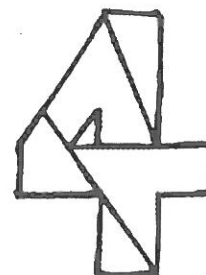
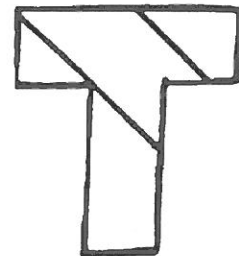
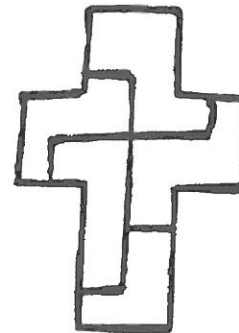
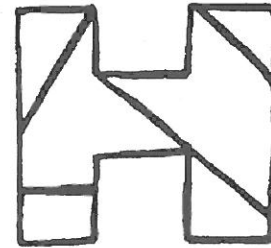
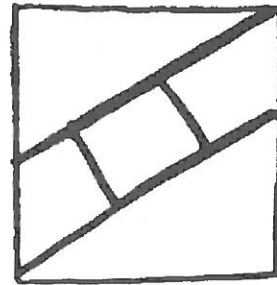
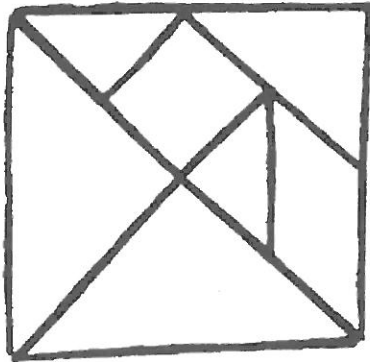

**Puzzles**

Draw a square on a piece of stiff paper or thin cardboard and divide it as shown below. Cut along the lines. The puzzle is to fit the pieces together again to form a square. (keep these pieces in an envelope and use again.)

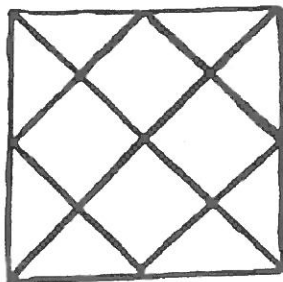

## CRAFTS

### Magic Crystal Garden

Watch beautiful crystals grow in this fascinating garden.

#### Ingredients Needed:

- 6 Tbsp - Salt
- 6 Tbsp - Water
- A couple of drops of food coloring
- 6 Tbsp - Laundry Bluing
- 1 Tbsp - Ammonia
- 5 or 6 pieces of charcoal

Mix salt, water, bluing, and ammonia in large bowl. Put 5 or 6 pieces of charcoal in glass container.

Pour mixture over charcoal pieces. Sprinkle drops of food coloring on charcoal to give your garden color. Set container in warm place. Check back from time to time to see how your garden is growing. It will continue to grow until the liquid is absorbed.

If you want to move your garden, move it gently to avoid breaking the delicate crystals.

You can make a mini garden by pouring the liquid over one or two pieces of charcoal on a small drinking glass or apothecary jar.

### Crushed Ice Candles

#### Materials:

- Disposable heat resistant container
- Candle wicking 2 inches longer than container
- Crayons or candle coloring
- Wax
- Crushed Ice

Cover working surface with newspaper, cut wax into small pieces and place in a double

boiler (do not melt wax over direct heat). As wax begins to melt, dip wick into it and stretch out straight on waxed paper to dry. Add color to wax. Color will be darker when wax cools. Wax will be ready to pour when it reaches 170 degrees F. If thermometer is not available, heat for a minute or two after wax is completely melted. When wax is about ready to pour, place weighted wick (use a paper clip) in container. Use a spring clothespin to hold wick at the top of container. Pour crushed ice around wick and pour wax over ice. Allow to cool until hard. To speed setting, place in refrigerator for 10-15 minutes. Pour out melted ice then remove the candle from the mold. It may be necessary to place the mold in hot water for 5-10 seconds to remove the candle.

**(Do not crush your ice too fine.)**

### Construction Ideas

Cover scrap wood or cardboard with colored cloth, paper, or contrasting paint. Glue on felt and wire, then add scrap items.

(A: Aluminum foil)

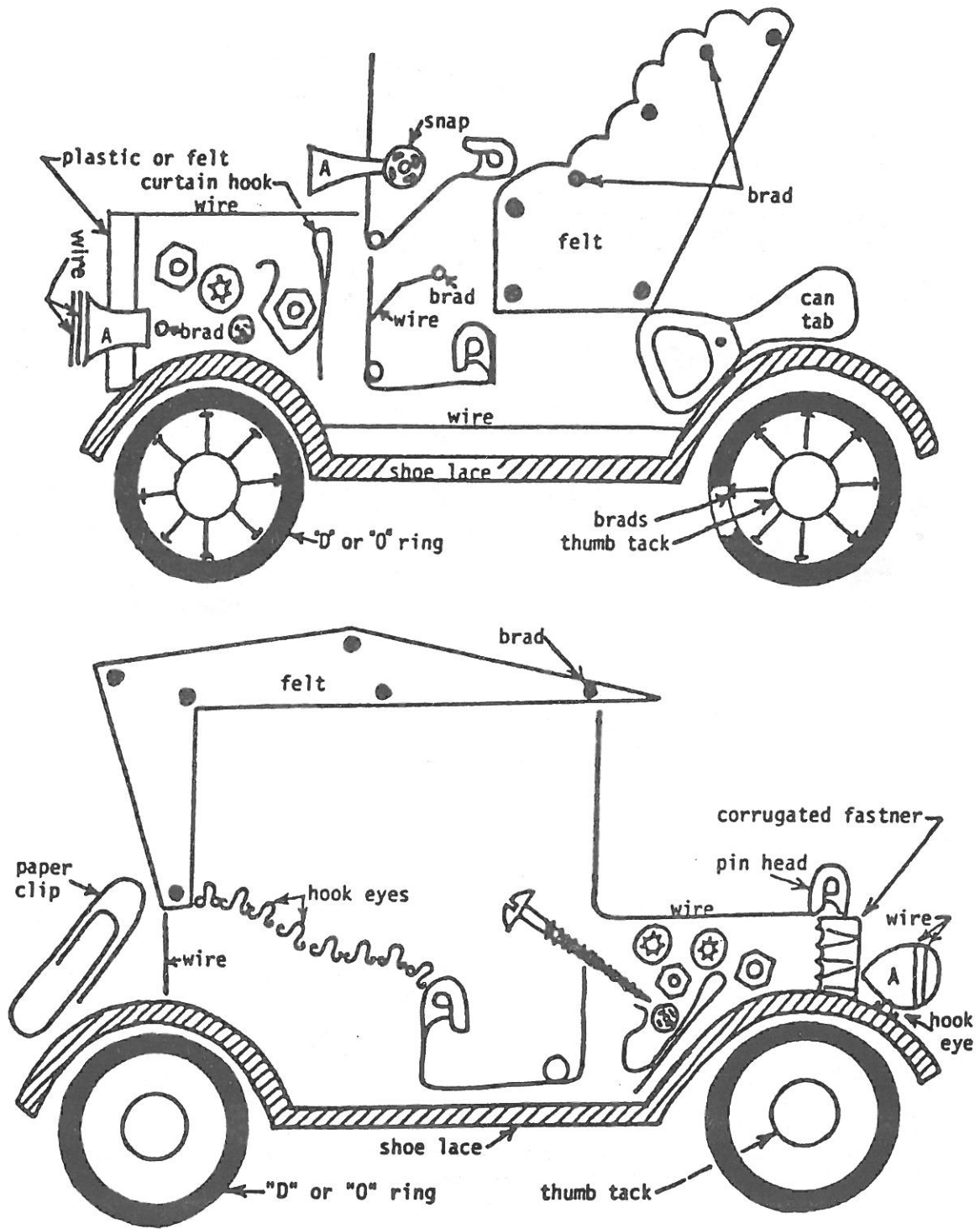

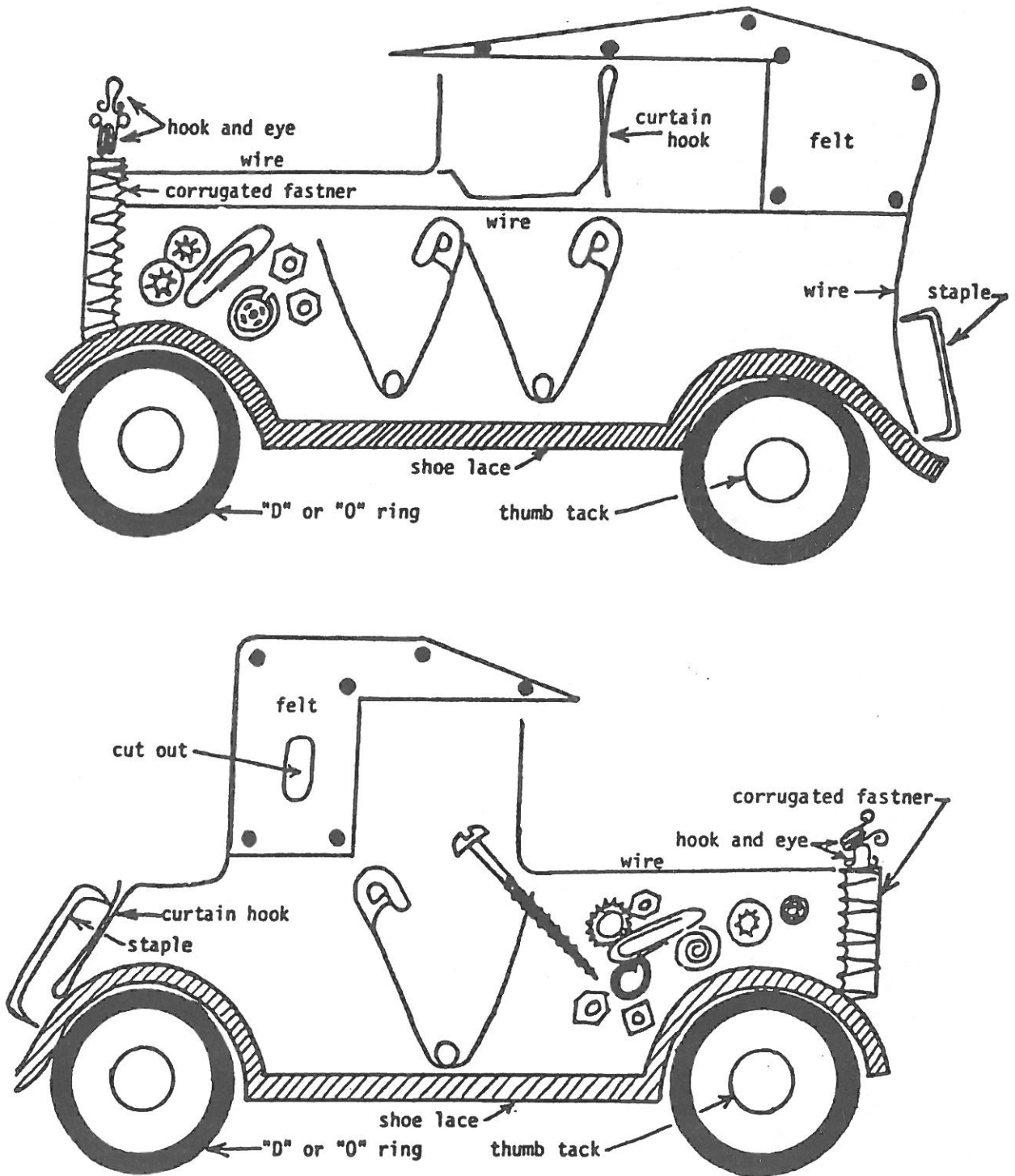

SKIT

Man:

(Giving up...) I quit- They will just have to find someone else to open up the Ticket Booth.

**The Ticket Line**

Characters:

Several fans

Man

Scene:

Fans are standing in line waiting to buy tickets.

Man enters at end of line

Fan #1 I can't wait to buy my tickets!

Fan #2 Me neither. This is going to be the game of the year.

Fan #3 When are they going to open up?

Fan #4 I've been waiting forever.

Man tries to push way to front of the line.

Fan #1 Hey buddy, get to the end of the line.

Everybody pushes him to the end of the line.

Man tries again to go to the front of the line.

Fan #2 Hey, I thought we told you to get at the end of the line.

Fan #3 The nerve of some people.

Fan #4 I wonder what is taking them so long.

Man tries again to get to the front of the line.

Fan #1 What's wrong with you? I've been here all morning and I'm the first.





