



# FIESTA!! FEBRUARY 2004



**Viva Fiesta! It's party time for Scouting and what better way to celebrate than with a Mexican flavor? Boys will learn about the country's festive traditions as they make cascarones and fill piñatas for the blue and gold banquet. Perhaps they can even learn to sing Happy Birthday or other songs in Spanish. They'll enjoy planning the menu too - fajitas or quesadillas, anyone? It's "nacho" ordinary blue and gold banquet! Ole!**

Cub Scout Theme .....	03
Webelos – Scholar .....	18
Webelos – Engineer .....	23
Tigers - How I Tell It .....	25
Cubmaster Corner - The World Friendship Fund .....	29

# FIESTA!!

## FEBRUARY 2004

### The Boy Under the Tree

In the summer recess between freshman and sophomore years in college, I was invited to be an instructor at a high school leadership camp hosted by a college in Michigan. I was already highly involved in most campus activities, and I jumped at the opportunity. About an hour into the first day of camp, amid the frenzy of icebreakers and forced interactions, I first noticed the boy under the tree. He was small and skinny, and his obvious discomfort and shyness made him appear frail and fragile. Only 50 feet away, 200 eager campers were bumping bodies, playing, joking and meeting each other, but the boy under the tree seemed to want to be anywhere other than where he was. The desperate loneliness he radiated almost stopped me from approaching him, but I remembered the instructions from the senior staff to stay alert for campers who might feel left out.



As I walked toward him I said, "Hi, my name is Kevin and I'm one of the counselors. It's nice to meet you. How are you?" In a shaky, sheepish voice he reluctantly answered, "Okay, I guess." I calmly asked him if he wanted to join the activities and meet some new people. He quietly replied, "No, this is not really my thing." I could sense that he was in a new world, that this whole experience was foreign to him. But I somehow knew it wouldn't be right to push him, either. He didn't need a pep talk, he needed a friend. After several silent moments, my first interaction with the boy under the tree was over.

At lunch the next day, I found myself leading camp songs at the top of my lungs for 200 of my new friends. The campers were eagerly participated. My gaze wandered over the mass of noise and movement and was caught by the image of the boy from under the tree, sitting alone, staring out the window. I nearly forgot the words to the song I was supposed to be leading. At my first opportunity, I tried again, with the same questions as before: "How are you doing? Are you okay?" To which he again replied, "Yeah, I'm all right. I just don't really get into this stuff". As I left the cafeteria, I too realized this was going to take more time and effort than I had thought - if it was even possible to get through to him at all.

That evening at our nightly staff meeting, I made my concerns about him known. I explained to my fellow staff members my impression of him and asked them to pay special attention and spend time with him when they could.

The days I spend at camp each year fly by faster than any others I have known. Thus, before I knew it, mid-week had dissolved into the final night of camp and I was chaperoning the "last dance". The students were doing all they could to savor every last moment with their new "best friends" - friends they would probably never see again. As I watched the campers share their parting moments, I suddenly saw what would be one of the most vivid memories of my life. The boy from under the tree, who stared blankly out the kitchen window, was now a shirtless dancing wonder. He owned the dance floor as he and two girls proceeded to cut up a rug. I watched as he shared meaningful, intimate time with people at whom he couldn't even look just days earlier. I couldn't believe it was him.

In October of my sophomore year, a late night phone call pulled me away from my chemistry book. A soft spoken, unfamiliar voice asked politely, "Is Kevin there?"

"You're talking to him. Who's this?" "This is Tom Johnson's mom. Do you remember Tommy from leadership camp? "The boy under the tree. How could I not remember? "Yes, I do", I said. "He's a very nice young man. How is he?" An abnormally long pause followed, then Mrs. Johnson said, "My Tommy was walking home from school this week when he was hit by a car and killed." Shocked, I offered my condolences. "I just wanted to call you", she said, "because Tommy mentioned you so many times. I wanted you to know that he went back to school this fall with confidence. He made new friends. His grades went up. And he even went out on a few dates. I just wanted to thank you for making a difference for Tom. The last few months were the best few months of his life."

In that instant, I realized how easy it is to give a bit of yourself every day. You may never know how much each gesture may mean to someone else. I tell this story as often as I can, and when I do, I urge others to look out for their own "boy under the tree."

David Coleman and Kevin Randall, Circle Ten Council

# FIESTA!!

## FEBRUARY 2004

### Gathering Activities

#### WHO IT IS

Give everyone a 3x5 card. Have them all write down 4 things about themselves that no one else in the room should know. Have them put their name on the top of the card for future reference. Collect the cards. Then pass out a piece of paper to each person. Read the cards one at a time and have everyone write down who they think the person on the card is. Then read off the correct results (the names from the top of the cards) while they check their lists. The person who gets the most right is the winner.

#### OLE WHAT DOES IT MEAN

Interpreting some simple Spanish words can also be a good activity. Make a list of some simple Spanish words and have guests list the meanings of the words.

#### PASS THE SOMBRERO

Another game idea is to use a sombrero at each table, each time a person says the word "Fiesta" they have to wear the sombrero, until someone else says the word. Then that person wears the sombrero.



# FIESTA!!

## FEBRUARY 2004

### Openings

#### FIESTA WELCOME

*SETTING: 7 cubs hold large colored cardboard cutouts of balloons, which have the letters, WELCOME on the back.*

W - Cub 1: Welcome to each and every one.

E - Cub 2: We're going to have lots of fun.

L - Cub 3: Let's now officially open our meeting.

C - Cub 4: We give to you a friendly greeting.

O - Cub 5: Our displays today you will enjoy.

M - Cub 6: There's something here for every adult and boy.

E - Cub 7: Now we ask that everyone stand as we sing a song about our land.

Lead audience in "America the Beautiful."

#### FIESTA

NARRATOR: Fiesta, a time for family, fun, food and traditions. A time for parades and parties and fireworks. Tonight our Pack \_\_\_\_\_ presents its own Fiesta.

(Four Cubs each wearing a colorful Mexican clothing and sombreros if desired.)



CUB #1: Fiesta can come at any time.

CUB #2: Fiesta is a time for family traditions and sharing your love for each other.

CUB #3: Fiesta is a time for homemade dishes. piñatas and good music.

CUB #4: Fiesta is another word for having fun.

NARRATOR: Tonight as we meet in the spirit of fun, we also want to remember our respect for each other and the flag, which represents us all. Will you please stand and say the "Pledge of Allegiance" with us.

# FIESTA!!

## FEBRUARY 2004

### Blue and Gold Fiesta Ideas

- ◆ Decorate (and wear, if possible) red, green, and white (the colors of the Mexican flag), make (or buy) some Mexican food, play festive Mexican music, and have a great time! For dessert, fill a Piñata with candy, and challenged your guests to one swing each, blindfolded, to see who can break open a Piñata, for all to enjoy the candy inside.
  
- ◆ Fun Invitation ideas for a Mexican Fiesta include:
  - Mexican flag design
  - Sombrero shape
  - Photo of Chihuahua dog
  
- ◆ Fun Party Favors for a Mexican Fiesta include:
  - Spanish word book
  - Maracas
  - Finger cuffs
  - Jump rope
  - Marbles
  
- ◆ Party favors can include maracas, individual boxes of Mexican Jumping Beans, treat bags with poppers, toys, and candy from the piñata.
  
- ◆ If you have access to a large Mexican flag, hang it at a focal point in your room. Then, use smaller flags to decorate the walls and doors, etc. Or, Mexican Flag bandanas to decorate, or as napkins!
  
- ◆ For an authentic touch, visit your local travel agent and try to get posters of Mexico - some city scenes, some beach scenes and scenes of some of the historic ruins. You can mount these on foam core and hang them on the walls.
  
- ◆ For appetizers, you could do something as simple as salsa and chips. Check the grocery store for different types of chips -- they have blue and black tortilla chips as well as flavored tortilla chips (including lime) .Serve them in a Sombrero chip & dip holder for more fun! You could then have an assortment of salsas -- some mild, some spicy, etc. You could also make nachos, a bean dip and a cheese dip. Of course, you will have to serve guacamole. If you don't feel like making this, check with your local Mexican restaurant -- they can definitely supply you with some. Fajitas, quesadillas, refried beans and Mexican rice would be super for your entree. Be sure to have both beef and chicken fajitas, as well as veggie fajitas, to accommodate all tastes.
  
- ◆ Everyone loves to make their own tacos, so try Tacos with their favorite toppings: cheese, lettuce, tomatoes, salsa!

# FIESTA!!

## FEBRUARY 2004

### More Blue and Gold Fiesta Ideas

- ◆ Have Maruichi music playing at the party or have a Maruichi band playing. Los Lobos would be a good band music to select for your Fiesta. Once the party gets going, play the Macarenas and get everyone out dancing!
- ◆ For Drinks serve a non-alcoholic sangria mix, soda and sparkling water garnished with lime slices.
- ◆ Set the mood and create instant fun when you set your table with brightly colored plates, cups and napkins. Fiesta flowers, carefully placed houseplants, live Cactus Plants , colorful tin candles as centerpieces on the tables.
- ◆ Gotta have chips and salsa, try serving the chips in a sombrero or sombrero chip and dip tray. Put on some festive music, and you're ready to party Fiesta-style. Serve Frozen paletas
- ◆ Serve Frozen Juice Bars for dessert.
- ◆ "Choco-Tacos" (ice cream sandwiches made with flat cookie cone folded over like a taco) for dessert.

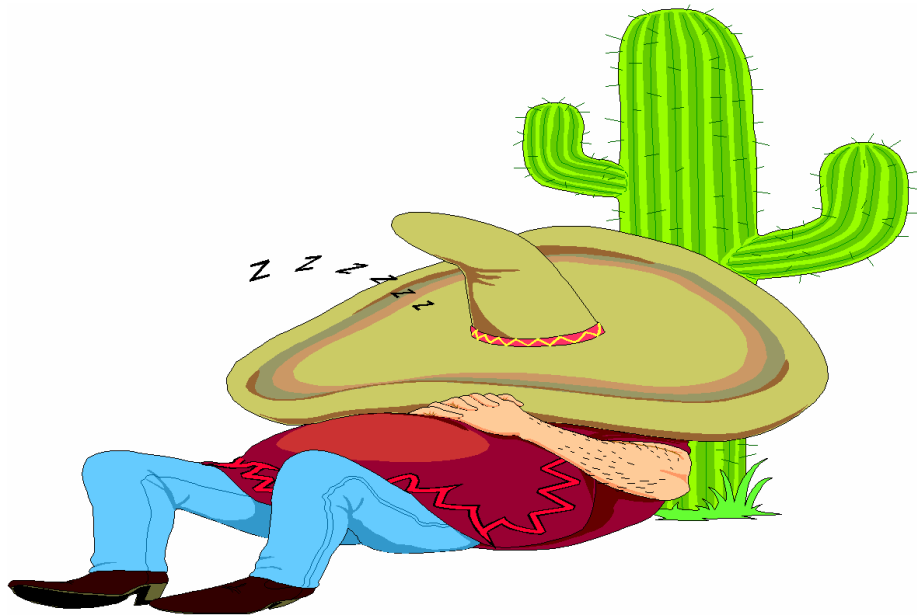

# FIESTA!!

## FEBRUARY 2004

### Crafts

#### PAPER MACHE MARACAS

Cover water bomb sized balloons with paper mache.

When they were completely dry, cut off the tied end of the balloon

Insert dried beans and rice.

Use a length of wooden dowel and hot glued them in place for the handle.

Painted maracas with bright festive colors and designs.

#### WATER BOTTLE MARACAS

Materials needed for each maraca

*plastic water bottle*

*a cup of rice*

*construction paper*

*Cinco De Mayo stickers, from the craft store*

#### DIRECTIONS

1. Fill the bottle with rice.
2. Cover bottle with construction paper.
3. Let the children decorate them with the stickers.

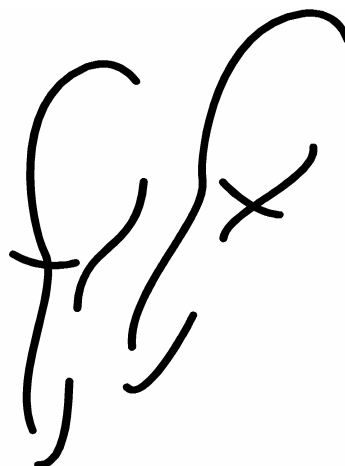

#### PAPER PLATE MARACAS

##### You will need:

*9-inch paper plate*

*Markers or crayons*

*Handful of dried beans or rice*

*Stapler*

*Five or six strips of colored crepe paper or streamers.*

#### DIRECTIONS

1. First, decorate the outside (bottom) of the paper plate- use bold designs and bright colors!
2. Fold the plate in half and put a handful of beans or rice inside.
3. Staple it shut.
4. Then staple the colored streamers to the curved side of the plate.

Now shake your maraca, and make your own music!



# FIESTA!!

## FEBRUARY 2004

### More Crafts

#### RED PEPPER STREAMERS

Twist tissue paper into the desired shape

Then covering them with masking tape

Painting them red.

When dry secure to a strand of jute rope and hang

#### SERAPE

A traditional Mexican serape can make a wonderful addition to your Cinco de Mayo attire!

##### You'll need:

*A large brown grocery bag*

*Scissors*

*Masking tape*

*Poster paints.*

##### DIRECTIONS

Cut straight up the seam on the back of the bag, branching into a "V" and then a hole in the bottom of the bag (this is the neck hole).

cut about a 5-inch wide strip from each side of the bag. This makes the open sides of the serape.

Make fringe around the bottom by either cutting slits all around the edges, or by punching holes along the bottom and threading pieces of yarn through.

Turn the serape inside out, so that the print is inside, and the side that is showing is plain brown. You may need to secure the shoulder area (the bottom of the bag) with masking tape.

Lay your serape out flat, and paint with bright colors!



# FIESTA!!

## FEBRUARY 2004

### More Crafts

#### PAPER FLOWERS

To make paper flowers you will need:  
long, colorful, tissue paper  
pipe cleaners (one per flower)

#### DIRECTIONS

First, take the tissue paper and put six pieces, one on top of each other, and then, fold it like you would fold a paper fan. Next, take one pipe cleaner and tie it around the center. Now, take the tissue paper that is still folded like a paper fan and pull the paper up. Make sure you do not pull too hard or it will tear. Now, you should have a paper flower.

#### PAPEL PICADO

In Mexico, *papel picado* (perforated paper), refers to the traditional art of decorative cut paper banners. Papel picado are usually cut with sharp *fierritos* (small chisels) from as many as fifty layers of colored tissue paper at a time. Designs may incorporate lattice-work, images of human and animal figures, flowers, and lettering. Many papel picado are made especially for the Mexican festival



#### Making Simple Papel Picado

Fold a rectangular piece of paper in half. In pencil, sketch one half of a design on one of the folded halves. Rulers may be used to divide the paper into grids or sections. Objects or designs must touch and connect to other areas of the paper as they form the positive shapes on the paper. Negative areas to be cut away may be shaded in pencil to aid in cutting. Use scissors or a craft knife to carefully cut away negative areas of the design (cut over cardboard if using craft knives). Open slowly, flatten, and glue to a background paper. To create more complex designs, fold the paper more than once. Try using different kinds of paper: butcher paper, fadeless colored paper, origami paper, and colored tissue paper.

# FIESTA!!

## FEBRUARY 2004

### Songs

#### BLUE AND GOLD

(tune: Clementine)

Each group sings the line that has their name in ( )

We're the Cub Scouts (boys)  
We're the Scouters (adults)  
Here we are both young and old (all)  
Altogether we're a Cub Pack  
Having fun at Blue and Gold.  
Tigers and Bobcats (Tigers and Bobcats)  
Wolf and Bear Cubs (Wolves and Bears)  
And the WEBELOS are we. (WEBELOS)  
Altogether we're a Cub Pack  
Having fun in harmony.  
We're the mothers (moms)  
We're the fathers (dads)  
Helping Cub Scouts as they go. (adults)  
Up the ladder of achievement,  
Climbing higher as they grow.  
Let's give thanks (everyone)  
On this occasion  
To the mighty Gold and Blue;  
Pack \_\_\_\_ is the number  
Representing me and you.

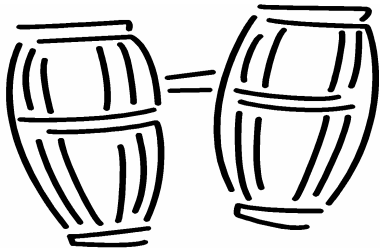

#### A SMILE

(tune: Auld Lang Syne)

A smile is quite a funny thing,  
It wrinkles up your face,  
And when it's gone you'll never find  
It's secret hiding place.  
But far more wonderful it is  
To see what a smile can do;  
You smile at one, he smiles at you,  
And so one smile makes two.  
He smiles at someone since you smiled  
And then that one smiles back,  
And that one smiles, until in truth  
You failed in keeping track.  
And since a smile can do great good  
By cheering hearts of care,  
Let's smile and smile and not forget  
That smiles go everywhere.  
-Nashua Valley/Pioneer Valley Pow Wow 1996

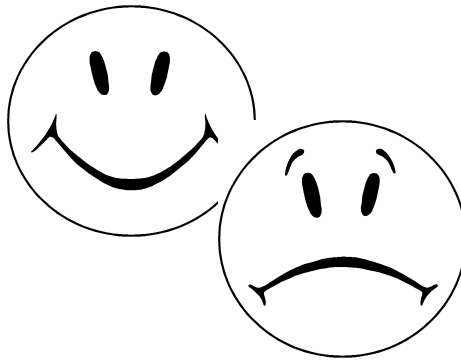

#### MEXICO

(tune: Are you Sleeping?)

Mexico, Mexico,  
Fiesta time is here  
Bringing us all the fun .  
Laughter for everyone.  
Here we come, Here we come

# FIESTA!!

## FEBRUARY 2004

### Skits

#### HAPPY BIRTHDAY

Explain that in Mexico on your birthday you are treated with hot chocolate and tamales. Tamales are a special treat and are usually made on special holidays and events. At birthday parties nobody sings "Happy Birthday to you"; instead everybody will sing "Las Mañanitas" ... "These are the little morning songs that King David used to sing to beautiful girls. Now we sing them to you. Wake up my love, wake up. The sun is already up, the birds are singing and the moon is gone". You'll then be invited to share the tamales and hot chocolate.

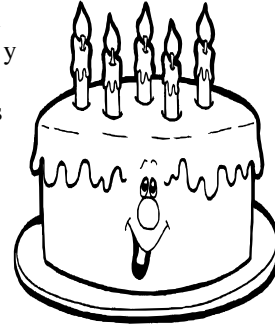

Have the boys act out this event. One boy can be the birthday child and the rest can be his family coming to sing to him. After everyone sings, he pretends to eat and drink.

Everyone then turns to the audience and wishes Scouting a Happy \_\_\_\_ (years) of Scouting.

#### THE PARTY WAREHOUSE

*Cast: Warehouse Person, Store Manager, 5 Customers, Two Victims, Broomstick*

*Setting: Party Supplies Store*

*Props: Get two victims to hold, at each end, the broomstick -- this will be your manager's store counter.*

Customer #1: Hi! I'd like to buy some balloons for my daughter's birthday party.

Manager: Of course, Sir. Let me check with the back. (Calling to back of warehouse.) Do we have any balloons?

Warehouse: (Calling from back -- an accent works well, or he's hard of hearing.) Let me check. (Pause) No! No balloons!

Manager: Gee, I'm sorry, Sir. Thank you for stopping by!

Continue with each customer trying to get cakes, party favors, "Just the bottom of the line, no frills birthday party supplies," candies, games for the little darlings, hats, and so on. Each time, the Manager calls back, the warehouse person responds that he'll check, says no, and the manager apologizes. Finally,

Last Customer: I've been waiting in line here for a while and I've noticed that you don't have anything that anybody wants. What do you have for parties?

Manager: (Slowly looks at each of the victims, considering each.) Well, I do have two suckers on a stick!

# FIESTA!!

## FEBRUARY 2004

### Games

#### **BENITO JUAREZ SAYS**

##### **How To Play:**

Before playing explain to the children that Benito Juárez, a Zapotec Indian, was born and raised in extreme poverty. With hard work, determination, and strong love for his country, Juárez became the president of Mexico and defeated the French, who had occupied the country for five years.

##### **Played similar to Simon Says.**

The player up is "Benito Juárez". Player will say "Benito Juárez says hop on one foot". The children will hop on one foot. Player will say "Stop". The children are to keep hopping on one foot until player says "Benito Juárez says stop". Repeat for additional activities such as take one baby step forward, step backwards, turn around, sit down. Sometimes Benito Juárez will say "Benito Juárez says" and sometimes he won't.

#### **BUENOS AMIGOS (GOOD FRIEND)**

##### **Supplies:**

Paper  
Pen  
Timer

##### **How To Play:**

Set the timer and have the boys write as many kind things as they can think of about their (amigo) on their right. The last boy writes about the first boy. Suggest that they write kind things about how their amigo acts, thinks, plays, works or looks. Give the paper to the amigo to take home.



#### **MEXICAN HAT DANCE**

Gather the boys and sit in a circle. Explain that a Mexican hat dance is a traditional Mexican dance done around a Mexican hat, which is called a sombrero. Place a sombrero on the floor and play some Mexican music. As you call each boy's name, the boy goes into the circle and dances as desired around the sombrero to the music.

# FIESTA!!

## FEBRUARY 2004

### Advancement Ceremonies

#### **GOLD AND SILVER ARROW CEREMONY**

*Equipment: Arrows (gold and silver) and Arrow cards*

*Personnel: Cubmaster; Assistant Cubmaster (or Den Leader Coach)*

**Cubmaster:** Tonight we have some Wolves and Bears who have been hard at work on their electives and so (number) of them have done enough to earn their Gold Arrow under Wolf (Bear) and (number) have earned their Silver Arrows. I would like the following boys and their parents to come up onto the stage with the parents standing in back of their sons. (Read list of boys and whether gold or silver arrow, and under which badge).

Cubmaster: It gives me great pleasure to award these boys their Arrow Points tonight. As I read your names, \_\_\_\_\_ our Assistant Cubmaster, will hand you the awards with our congratulations for a job well done.

After this is done, the Cubmaster says:

These boys have learned how to make and do many useful and fun things while working on these electives. For each 10 projects he completes, he receives an Arrow Point, so that you can see that these boys have been busy fellows indeed. For all of their fine efforts, we're doing to give them a special applause stunt.

- Detroit Area Council, Pow Wow 1990



#### **BOBCAT CEREMONY**

*Personnel: Cubmaster, Den Chief, Den Leader, Bobcat candidates and parents*

*Equipment: Ceremonial Board consisting of arrow with three candles on a balance, Bobcat pins and advancement certificates*

**Cubmaster:** Will the candidates and their parents please come forward and face the pack. (They do so) You boys and your parents have come to be inducted into our Cub Scout family as members of Pack \_\_\_\_\_. You are ready to start your adventure along Akela's trail, together with your friends and their parents.

Here is the arrow (points to ceremonial board) that points the way along the trail. The awards you can earn along the trail are: the Wolf, the Bear, the WEBELOS, and the Arrow of Light awards. The parts of the Cub Scout program that cannot be seen are the value of things you will learn and the good times you will have.

This is the scale of Akela. Both the parents and the Cub Scouts are important to keep the scale in balance.

(To Den Chief): (name), will you light the candle representing the Cub Scouts. (Candle on feather)

(To Den Leader): (name), will you light the candle for the parents. (Points to the candle on the arrow point)

If the boy does not do his part, the scale is out of balance and the program goes downhill. (Removes candle representing boys, then replaces it) On the other hand, if the parents part is taken away, the scale is out of balance in the other direction and the Cub Scout loses his way along Akela's trail. (Removes candle representing parents, then replaces it)

# FIESTA!!

## FEBRUARY 2004

### Advancement Ceremonies

#### **BOBCAT CEREMONY continued**

So, you see, to keep the Cub Scout program in perfect balance, both Cub Scouts and parents must take part in the activities by coming to all meetings, following the leaders, and advancing from point to point along Akela's trail.

No boys, give the Cub Scout sign, and repeat the Promise with me.

(They repeat Cub Scout Promise)

And, parents, will you please repeat the following: We, as parents, will do our best...to aid and assist our son...in his Cub Scout activities. We will encourage him with enthusiasm...criticize him with fairness...and judge him with lenience. And, realizing that the Cub Scout program...is one of equal participation for boys and parents...we will assist as we are able...in serving as leaders, advisors, or workers.

-Bay Area Council Pow Wow, 1994

#### **I SALUTE YOU**

**CUBMASTER:** Tonight I have the honor of presenting the Arrow of Light to one of our WEBELOS Scouts. Would (name) and his parents please come forward to receive this award, a WEBELOS Scout must have passed the following requirements: Been active in the WEBELOS den for 6 months, have earned the WEBELOS badge, know the Scout Promise and the Scout Law, give and know the meaning of the Scout Motto, slogan, sign, salute and handshake, know the hurry cases in first aid, have earned a total of seven activity badges, have visited a troop meeting with his den attended an outdoor activity, participated in a father-son overnight or day hike and attended another troop meeting but this time with his parents.



Will you now light the candles in the order of which you have progressed along the Cub Scout trail. From Bobcat to WEBELOS. Now welcome to the highest award, the Arrow of Light, which you, with the help of your parents, have obtained. So it gives me great pleasure in giving this award to your parents to present to you. Because your parents have helped you along the Cub Scout trail, here are the miniature Arrow of Light pins for you to present to them. I salute you, (name), as a WEBELOS Scout. You will soon know the adventure of a Boy Scout.

# FIESTA!!

## FEBRUARY 2004

### Run On/ Applause

**MEXICAN HAT DANCE:** Put hands on feet and stamp feet while turning around in a circle.

**PARTY CHEER:** Throw hands in the air and say, "Confetti, Confetti, Confetti."

**PEPPER:** Pick a pepper off a vine or tree, look at it, lick your chops. Take a big bite, chew and swallow. IT'S HOT, REALLY HOT--express it by holding your throat and "Water."

**PINATA CHEER:** Pretend to hit piñata, say "Swoosh" (Miss), "Swoosh" (miss), "Swoosh" (hit) "HOORAY."

**TORTILLA:** Slap both hands together, alternating one hand and the other from top to bottom. On every fourth clap, shout, "OLE!"

**SPANISH DANCER:** Stand with left hand on hip and right hand held above head in manner of flamenco dancer. Simultaneously, snap fingers of your right hand and stomp your feet in a fast tempo while turning slowly. Continue until you have made a complete circle. About every quarter turn, yell "Ole."





# FIESTA!!

## FEBRUARY 2004

### Closings

#### ADIOS

Boys hold cards spelling "ADIOS" which is Spanish for good bye. Each boy read one of the parts and after the last one is read, all boys shout "Adios."

A - We came together and had our fun. It seems as though we'd just begun.

D - We sang and danced and played some games. And had some fun with Spanish names.

I - We ate new foods and learned how Spanish children play and shout.

O - We dressed in ponchos we had made, and took siestas in the shade.

S - But now the time has come to say, "Adios until another day!" "ADIOS ! "

#### THANK YOU PARENTS

*Personnel: 8 Cub Scouts*

*Equipment: Large poster divided into 8, when put together has a heart on it with the words THANK YOU in it.*

*Setting: Each boy has a piece of the heart. After all lines have been read, the first four stand in a line and hold their cards while the second four kneel in front and hold up their cards so that the heart is formed.*



Cub 1: Our leaders are grand, the best in the land

Cub 2: They deserve a thank you, and a big hand, too.

Cub 3: This celebration's the time and the place, to tell them we think so, right to their face.

Cub 4: So thanks to the Den Leaders, Committee and Cubmaster, at making Scouting fun, they're truly the masters.

Cub 5: But there's someone special we don't want to leave out, after all, they're a big part of what Scouting's about.

Cub 6: We want to say thank you, Mom and Dad, and tell you that we are really glad.

Cub 7: To have you as parents, yes it's true, because of your help and all that you do.

Cub 8: To help us through Scouting's achievements and ranks you truly deserve our heartfelt thanks.

Source: Simon Kenton Council

# FIESTA!!

## FEBRUARY 2004

### After the Meeting

#### **BUNUELOS (fritters)**

Recipe used at Christmas in Mexico

Makes about 3 dozen.

2 cups sifted flour

2 tbsp. sugar

1/2 tsp. baking powder

1/2 tsp. salt

1/4 tsp. anise seeds, crushed

1 tsp. grated lemon rind

1 egg, beaten

2/3 cup honey

1/2 cup oil

Combine flour, sugar, baking powder, salt, anise, and lemon. Stir in , egg, and enough milk to create a dough. Roll out to thin rounds 7-8 inches in diameter. Heat oil in a shallow skillet until hot.

Quarter each round and drop flat into hot oil, brown lightly about 30 seconds on each side. Remove from skillet and sprinkle to taste with topping mixture of cinnamon and sugar.



#### **CACTUS CAKE**

Make a cake in the shape of a very large cactus with toothpicks for spines.

Use one 9 x 13 cake, cut in half lengthwise and place one piece above the other to form the center of the cactus. From a second 9 x 13 pan cut 2 arms for the cactus, or use a horseshoe shape pan and cut apart in the center placing one piece on each side of the center cactus for the arms.

#### **NACHOS**

You will need tortilla chips, shredded cheddar or jack cheese, and your choice of optional items including: ground meat, refried beans, olives, tomatoes, jalapenos, etc. Spread the tortilla chips evenly on a baking tray. Sprinkle the shredded cheese evenly over the chips, alternating with your other optional items. Bake in a 350 degree oven for about 5-10 minutes (or until cheese is melted). Serve with salsa and sangria (recipe below!)

#### **SANGRIA**

In a large pitcher mix 4 parts purple grape juice, 2 parts seltzer, and 1 1/2 parts orange juice. Throw in some orange slices and cherries for decoration!

#### **TORTILLA ROLL UPS**

Serve rolled-up tortillas filled with different fillings. A cream cheese / salsa mixture would be good -- spread the mixture onto the tortilla, roll it up, cover and place it in the fridge. A few hours later, cut the rolled tortilla into 1-2" slices.

# FIESTA!!

## FEBRUARY 2004

### Scholar

#### DEN ACTIVITIES

Let the boys talk about what's going on in school. Don't try to change any of their ideas, but guide the discussion in such a way that they will see the value of an education.

Learn about the history of education, how schools developed in America.

Prepare a chart of the school system and explain and discuss with boys.

Discuss & do a den service project for the school.

Invite the parents of Webelos to come to a den meeting dressed in the type of clothes they wore to school. Have them bring along such things as class pictures, yearbooks, report cards, etc. and allow each ample time to share his/ her school days with the den.

Have a panel of parents with various jobs explain their schooling and training for these jobs.

Invite an educator to talk with the den about some of the scholar requirements.

As a den, talk about good study habits.

Have someone from the public library talk about the local literacy project.

Tour a local high school or visit a local college campus.

Play a Newspaper Search game looking for articles about education.

Encourage boys to find out all they can about schools in your community ... the different types and how they work... the problems and opportunities. Discuss these at a den meeting. Have the boys make a list of the things they like about school and another list of the things they don't like about school. Give these lists to the principal.

Have the boys make a daily time schedule and use it to determine if they are making the best use of their time.

#### Careers in Education

Have each boy choose one career in education and think of what may be involved in that career. Have them make a collage of pictures that relate his ideas about that career. You may be surprised at a Webelos Scout's perception of some of these jobs. When done, discuss them and clarify any misconceptions.



# FIESTA!!

## FEBRUARY 2004

*Be sure to check out February 2005 for more ideas on Engineer and Scholar!!*

### Scholar

#### **SPEAKERS**

Teacher  
College professor  
School principal  
Librarian

#### Additional ideas:

Invite a member of the school board or a professional educator (teacher or principal) to talk to the boys on the value of an education and what school has to offer a boy.

Have the boys try to find out some of these things: What jobs are there at school for the boys to do? What extra-curricular activities are available? What community activities is the school used for? Who are the people on the office staff, cafeteria staff, and custodial staff? What are their responsibilities? What are some of the problems of the school, and how can you help?

Have the boys list what they consider the best and worst things in their school. Arrange to give these lists to the principal or a school board member. Invite them to a den meeting to talk with the boys. Important to the participants in such a meeting is a feeling of trust and comradely. Allow the meeting to have an informal setting. After respectfully introducing the guest, let it become an informal rap session. A few cookies and punch served by the denner has worked wonders in the past. Now is the opportunity for the leader to blend into the woodwork and enjoy observing. Do not become concerned with a lack of participation on the boys' part. If the guest is someone concerned with the boys of this age group, he or she will draw them in. A little more informal would be a meeting at school between the boy and a teacher. Have the boy list questions and set up approximately 10 minutes to meet. Have the boy discuss his meeting at a den meeting.

#### **FIELD TRIPS**

Plan a trip to the library to have the librarian demonstrate the use of a microfilm or microfiche viewer.

Ask a librarian to explain the Dewy Decimal System, visit the public library, have the boys complete applications for a library card if they do not already have one.

Briefly visit a school board meeting. Let them know you are coming. They may be interested to know the boys are working on the Scholar Activities Badge.



# FIESTA!!

## FEBRUARY 2004

### Scholar

#### GAMES

##### SPELLING MIXER

Print large letters on 5x8 index cards, one letter per card. Do not use the letters J, K, Q, V, X or Z. Make several cards with vowels on them. Have a card for each person in the group. On signal, the Cubes hold up their cards, then rush around to find two other people with letters that when combined with theirs, makes a valid 3-letter word. They must lock arms, in order and rush to a judge who writes their word on the back of their card if the word is valid. Then they separate and each rushes to find two more letters to make another word. Play continues for 5 or 10 minutes. The winner is the person with the most words on his or her card.

##### THE TWENTY-FIRST CENTURY

Have the boys discuss what they think school will be like 25 years from now. Will the students all be at computers? Will they interact with teachers from a TV hookup from their homes? Will they travel to Mars for math and Saturn for science? Will someone have invented a smart pill for every subject? In the future, will we do away with some of the subjects that are taught now? Which ones? What new subjects might be offered? Divide them into groups to make posters of their view of education in the future.

#### THINGS YOU CAN DISCUSS

##### Seven Ways to Improve Grades

**Learn to Listen** - Look at the speaker, concentrate on his words, take notes, participate in discussions.

**Develop Good Study Habits** - Avoid distractions, have supplies handy, do homework at the same time each day, make a list, do the things you hate first, schedule a short break if needed.

**Use the Right Reading Technique** - learn to skim by glancing through whole paragraphs at a time; use slower, more careful reading when you must understand and remember.

**Improve Your Vocabulary** - look up words you don't know, write them down, use the word(s) in your next conversation.

**Sharpen Your Writing Skills** - brainstorm for ideas, organize your thoughts, keep sentences short, use neat handwriting, double check spelling and punctuation.

**Learn How to Take Tests** - study well ahead of time (don't cram), relax, then face the test; read the directions carefully; answers questions you know for sure, pace yourself, work steadily; go back and fill in missing answers as best you can; double check your work for careless errors and omissions.

**Develop a Positive Attitude** - you are what you think you are - use positive thinking!

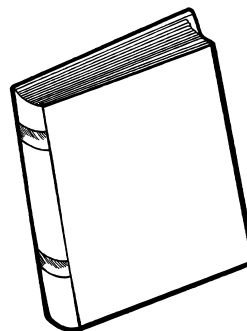

# FIESTA!!

## FEBRUARY 2004

### Scholar

#### HISTORY OF AMERICAN EDUCATION

Each of the paragraphs below contains information about education during four different periods of American history. Discuss what America was like during each period, then, as a den, read each and decide which period the information most probably reflects:

**Colonial** = America during 1600 - 1775

**Early 19<sup>th</sup>** = America during 1775 - 1865

**Late 19<sup>th</sup>** = America during 1865 - 1915

**20<sup>th</sup> Century** = America from 1915 on

1. \_\_\_\_\_ Education reflected and participated in the development of "The American Way." American History was instituted in schools during this time period. Education became more secular in nature, and state enacted laws requiring compulsory school attendance.
2. \_\_\_\_\_ Resources were limited and physical demands left little room for education. Education was initially established for religious motives (Puritans in New England.) Most education of this period was either in the home or apprentice training. Nine colleges were formed during this time period.
3. \_\_\_\_\_ Enrollments in elementary and secondary schools were above 90% of the eligible students. Wide inequities developed between states and local school districts. America's schools have developed as the nation has advanced.
4. \_\_\_\_\_ As the population became more concerned with technology and material progress, education progressed in turn. Education was influenced by European immigrants and travel to Europe. Secondary education replaced the academy and public high school became a reality.
5. \_\_\_\_\_ Three practices of education were established during this time: 1) Compulsory education, 2) Public support of schooling, and 3) Three levels of education (elementary, secondary, and higher) were set up.
6. \_\_\_\_\_ This was the beginning of a movement toward state school systems. Establishment of the elementary level was completed. Secondary education was taken care of through academy training. Numerous new colleges were started in the early nineteenth century.
7. \_\_\_\_\_ Colleges increased their courses and programs. Teaching grew more toward a profession and teachers became concerned with a methodology of education.
8. \_\_\_\_\_ School efforts have been structured towards quality education; while the size of the education system increased in size greatly. In schools the vocational education program diversified its offerings, while general education was considered a preparation for earning a living. Schools began to look more toward the students vocational pursuits.

(Answers: 1-Early 19<sup>th</sup>, 2-Colonial, 3-20<sup>th</sup> Century, 4-Late 19<sup>th</sup>, 5-Colonial, 6-Early 19<sup>th</sup>  
7-Late 19<sup>th</sup>, 8-20<sup>th</sup> Century)

# FIESTA!!

## FEBRUARY 2004

### Scholar

#### CAN YOU FOLLOW DIRECTIONS TEST

This test is to see if you can follow directions. Concentrate, but remember, you have only two minutes to complete this.

Read everything before doing anything.

Put your name in the upper right-hand corner of this paper.

Circle the word "name" in sentence number 2.

Draw five small squares in the upper left-hand corner of this paper.

Put an "x" in each square.

Put a circle around each square.

Put a circle around each word in sentence number 5.

Put an "x" in the lower left-hand corner of this paper.

Draw a triangle around the "x" you just put down.

If you think you have followed directions up to this point, call out "I have."

Now that you have finished reading this carefully, do only number 1 and number 2.

You have finished. How did you do?



#### STUDY SKILLS

You are the captain of your very own scholar-ship, or learning. Teachers and parents can help, but how well you do in school depends greatly on how well you do your homework. School has just started. Imagine that your scholar-ship has just left port for a nine month cruise. You will decide how smooth the trip is going to be. You will set your goals and chart your own course. Before your scholar-ship really gets under way, it's a good idea to check your skills to find out where you need to improve. You'll want to get your scholar-ship into shipshape.

Draw a face that would show how well you think you use your study skills.

1. Lifestyle  
Do you allow enough time for sleep, rest and fun activities?
2. Assignment  
Do you keep up with and write down your assignments?
3. Schedule  
Do you set aside time to study?
4. Place  
Do you have a good, quiet place to study?
5. Organization  
Do you organize your study area?
6. Focus  
Do you keep your mind from wandering by remembering your study skills?
7. Review  
Do you ask yourself questions or have your parents ask you questions to make certain you understand what you have studied?

# FIESTA!! FEBRUARY 2004

## Engineer

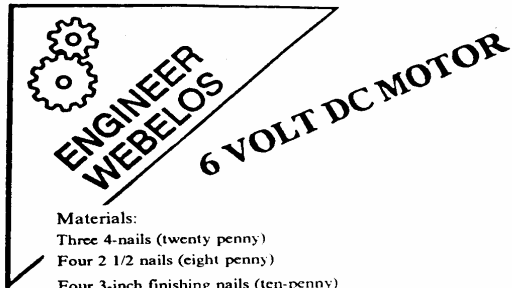

**Materials:**

- Three 4-nails (twenty penny)
- Four 2 1/2 nails (eight penny)
- Four 3-inch finishing nails (ten-penny)
- two dry cells or 8-volt lantern battery or 6-volt transformer
- One roll No.24 enameled wire
- Two staples (3/16 to 3/4") or four small brads
- Wood board for motor base
- Black plastic electrical tape
- Masking tape
- Two tacks

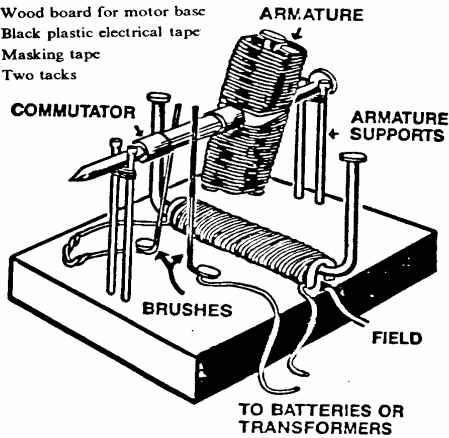

Note: Adjust position of the commutator and tension of brushes against it for best operation.

**COMMUTATOR**

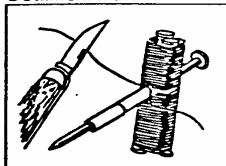

Scrape all insulation from ends of armature windings

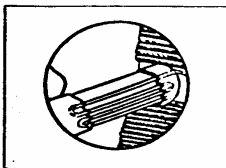

Position is critical

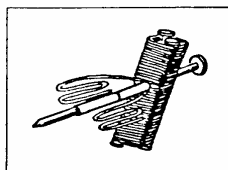

To form commutator, bend bare ends of wire as shown. Lay against the tape on the sides of the shaft halfway between the armature coils.

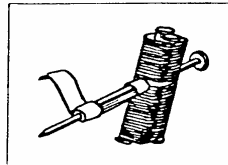

Hold commutator down with narrow strips of tape as shown.

**ARMATURE**

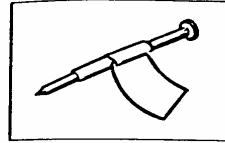

For armature shaft, wrap 1 1/2 inches of 4" nail with two layers of tape.

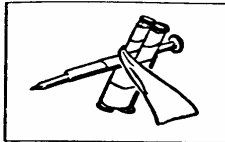

Center one pair of core nails on each side of shaft nail about 1 inch from head. Wrap with two layers of tape from tip to tip.

**FIELD**

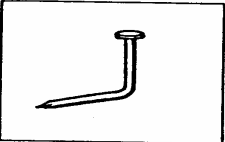

Bend two 4-inch nails in center for field core.

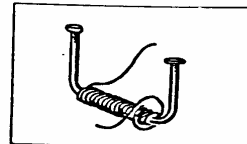

Leave 3 or 4" of wire at start and finish. Wrap the field core with about 40 turns of wire. After one layer is down, it may be difficult to see the spacing of the next layer. To make turns more visible, you can put down a thin strip of masking tape across the coil before wrapping additional layers. Leave room at each end of coil for attaching to wood base.

**ARMATURE SUPPORTS AND BRUSHES**

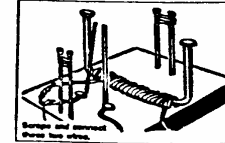

For armature supports, drive four 3" finishing nails into the base, locating them so that the armature turns exactly between the field poles. Wrap wire around the armature supports to form armature bearing.

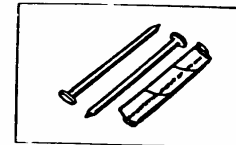

For armature core, tape two pairs of 2 1/2 nails, alternating heads and points.

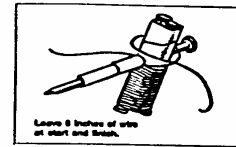

Wind armature with two layers of wire. Start at shaft, wind out and back on each half of core. Always wind in the same direction. Bend two 4" nails in center for field core.

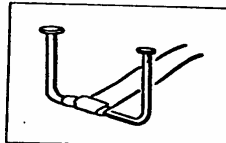

Space heads of nails at least 3" apart. (The spacing is critical; be sure the armature will clear the nail heads.) Wrap nails together with 2 layers of tape.

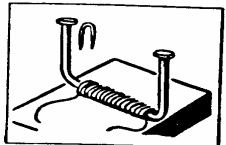

Attach to the wood base with staples or bent-over brads.

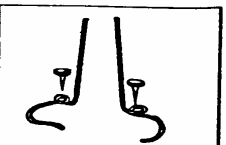

Scrap insulation from the ends of two 6" pieces of wire. Tack them to the base and bend as shown to form brushes.



# FIESTA!!

## FEBRUARY 2004

Engineer

### MODEL ELEVATOR

Nail Thread spools loosely to board, sip string over 1,2,3,4. Wind string several times around 2. Wind second string over 5 and 6 and attach weight for balance. Turn handle on 2 to move car up and down.

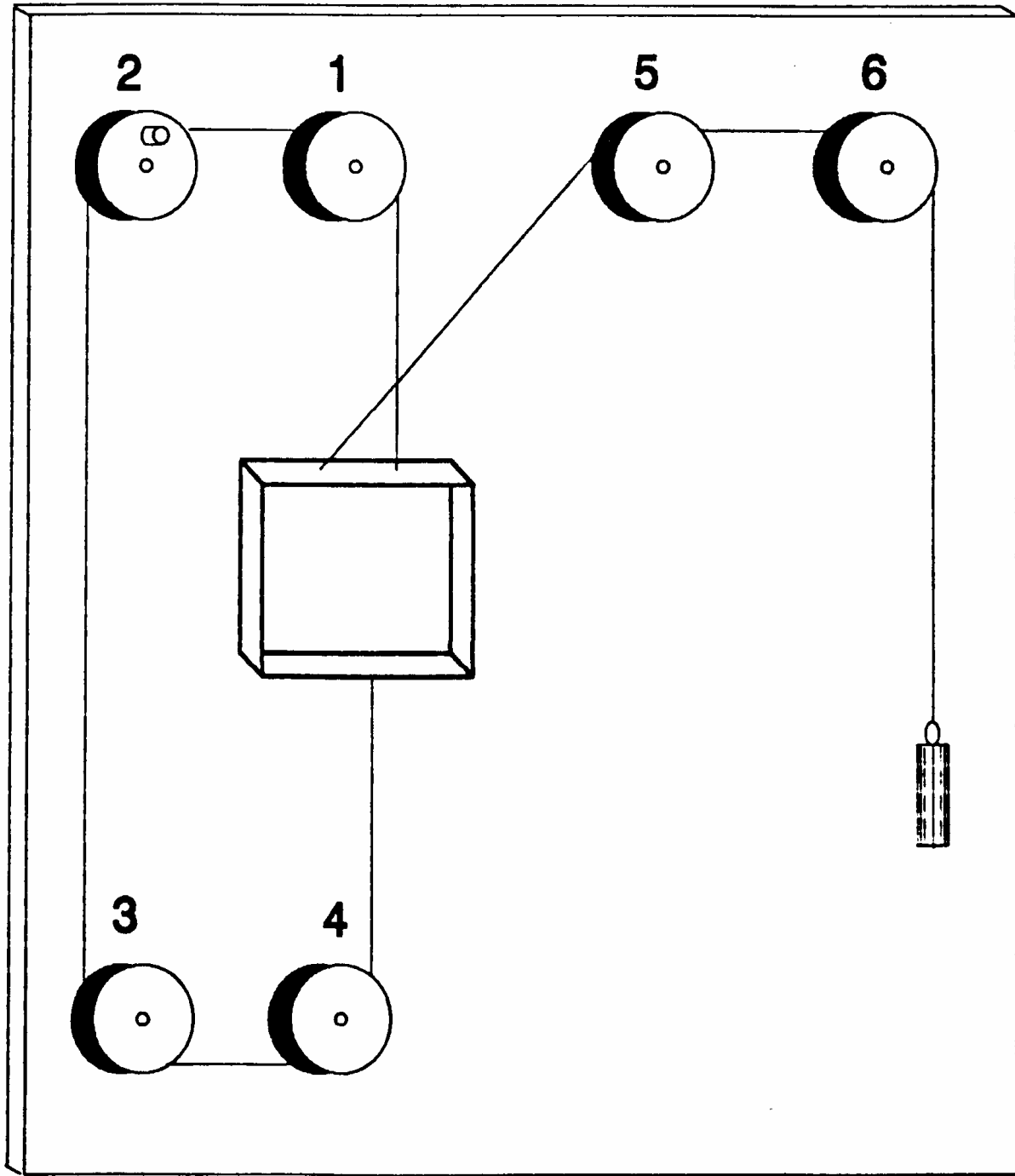

# FIESTA!!

## FEBRUARY 2004

### Tigers - How I Tell It

#### Family Activity

#### DISCUSS WITH THE BOYS

#### Delivering News or Spreading Gossip?

*If you can't say anything nice, don't say anything at all!*

Since the beginning of time, gossip has passed through every civilization and language. Whether intended to be mean-spirited or thought to be the simple relay of news and information, there is always someone who is the topic, and someone else who tells the story.



*There are two sides to every story.*

From a group of kids on the playground to a group of adults around the water cooler, the discourse targeted on an individual is as damaging to the speaker and his audience as it is to person(s) being discussed. How many times have you encountered a group of people discussing A particular individual, recounting only his or her good qualities?

*Believe only half of what you see, and none of what you hear.*

The spoken and written word can both create and destroy. Individual lives, careers, schools, towns, companies, and churches have been turned completely upside down and permanently altered by misinformation, lies, half truths, murmuring...by any other name it is still gossip. Today, as adults we can still look back to "that" girl in high school, "that" woman down the street, "that" teacher at school, "that" man at church. Though "they" were major topics of discussion, how different things might have been if more people had talked "to"

them rather than "about" them. Most victims of gossip desperately flail about like a drowning man, in attempt to fix the damage.

*Stick and stones may break my bones, but words can never hurt me.*

Our words can do as much damage and leave scars, sometimes worse than any physical injury. Almost any adult can recall an incident in their youth that left such a scar. Countless numbers of children (and adults) have dropped out of sports or other activities because of something said to them or about them.

*Time heals all wounds*

Children (and some adults) simply do not understand the concept of "just ignore it". It is hard for people to be forgiving. It is hard not to retaliate. In anger and pain, it is hard to see past today and look to next week. Children cannot reason with time. They have a hard time with the idea that things will look different in the morning. Getting even only creates more problems. Countering in the same manner that someone has hurt you, only makes you just another person out to hurt someone else. Two wrongs never make a right!

# FIESTA!!

## FEBRUARY 2004

### Tigers - How I Tell It Family Activity continued

*Don't worry, he'll outgrow it—not!*

Studies have shown that “verbally violent” behavior in children escalates into physical aggressive behavior. Children who “bully” their way through childhood grow into adults who bully their way through bad marriages, multiple jobs, and assorted bad circumstances that are never their fault

*How do you repair the damage done by gossip?*

*You can't.*

*Like the toughest and most ravaging diseases, the only cure is prevention.*

*Nip it in the bud*

Does your den have a “town crier”? The one child who has to be the absolute first to relay bad news, good news, what someone did at school, or a comment (usually inappropriate) he heard from an adult. He will probably be the first to tattletale and participate in name-calling.

Immediately put a stop to it the moment it occurs. Gather the boys in a circle and discuss the problem. Make it perfectly clear that name-calling, “tattling” (unless it’s endangering another person) and tale bearing will not be tolerated and that is not why we come to Scouts.

Take the time to clearly explain the difference between tattling and telling on someone for good reason. Is there incessant reporting of every minor perceived wrong on everyone else in the group or one person in particular by the same boy? Do you constantly hear from the same child “So and so is hitting me”, but he leaves out the part he kicked so and so first? Acceptable “telling” could be “Billy is running into the street in front of a car!” or “Nikey is playing with his pocket knife”. Give examples; keep going over and over it until everyone understands.

Point out that it is equally unacceptable to the receptive audience of “the town crier”. Being a party to a gossip session is as bad as actually telling the story. Discuss with the den what solutions they can come up with to not be apart of gossip

# FIESTA!!

## FEBRUARY 2004

### Tigers - How I Tell It

#### Den Activity

#### EXTRA, EXTRA, READ ALL ABOUT IT TIE SLIDE or SHIRT PIN

Have each boy design their own front page of a newspaper. Use a ¼ of a sheet of opaque shrink art (found in craft stores), and transfer the newspaper design onto it. Use fine tip permanent markers. Shrink according to directions on the package. Glue on a ½ " PVC pipe on the back to hold neckerchief or pin back that can be purchased at any craft store.

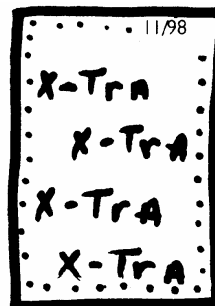

#### ADVERTISEMENT HUNT

Give each boy seated at a table a popular magazine, containing a large number of advertisements. Have in mind several products that are advertised in these magazines such as toothpaste, cars, soap, motor oil, etc. Start the game by calling out the name of the product. The boy/partner team, who first finds the proper ad, tears it out of the magazine and holds it up. If it is the right one, have them sit on it, and continue the game by calling for another. After about dozen or so calls, find out who is sitting on the most ads.

#### NEWSPAPER DELIVERY RELAY

Divide group into teams this includes partners! Give each team a tricycle, a bag, a few newspapers and rubber bands. On signal, the first player in each team rolls up a newspaper, and secures it with a rubber band, puts it in his newspaper bag, rides his tricycle to the turning point, throws his paper on the area designated as the "front porch", and returns to the starting point. Then the next player does the same until everyone has completed their turn. First team to complete deliveries is the winner.

#### NEWSPAPER SCAVENGER HUNT

Using a newspaper see how many of the following items each boy/partner team can find.

1. Find the names of two US States.
2. Find a picture of a smiling person.
3. Find a political cartoon.
4. Find another kind of cartoon.
5. Find a sale ad for a car.
6. Find the name of the Capitol of the US
7. Find a picture showing some kind of transportation.
8. Find a bar graph or chart.
9. Find an article that mentions a trial by jury.
10. Find the name of your state's governor.
11. Find a proper noun other than a person's name
12. Find a story in the sports section that mentions money.
13. Find the highest and lowest temperatures in the US.
14. Find two words that rhyme.
15. Find a sales ad for your favorite food.



# FIESTA!!

## FEBRUARY 2004

### Tigers - How I Tell It

#### Den Activity

#### **BRING BACK MY PENCIL**

*Tune: "My Bonnie Lies over the Ocean"*

My Cub Scout den went on a field trip  
To visit the newspaper shop.  
I was helping the presses print faster  
But suddenly everything stopped.

Bring back, bring back  
Oh bring back my pencil to me, to me.  
Bring back, bring back  
Oh bring back my pencil to me.

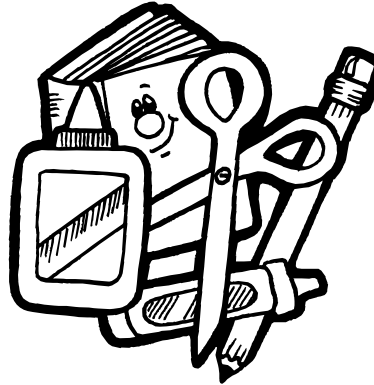

#### Go See It Outing

#### **FIELD TRIP/ PACK EVENT**

- ◆ Take a tour of your local paper.
- ◆ Take a tour of your local radio station.
- ◆ Take a tour of your local TV station.
- ◆ Visit a Computer company.
- ◆ Visit a print shop.
- ◆ Visit a reporter, editor, photographer, etc.
- ◆ Visit a journalism teacher - learn how important writing, grammar and spelling skills are.

# FIESTA!!

## FEBRUARY 2004

### Cubmaster Corner - World Friendship Fund

#### THE WORLD FRIENDSHIP FUND

The World Friendship Fund of the Boy Scouts of America offers a practical Good Turn opportunity for BSA youth members and leaders. Cash contributions are used to assist Scouting through the World Organization of the Scout Movement and through national Scout associations in developing countries. Tax deductible contributions can be from individuals, units, camp, and training course groups. Unit participation in the World Friendship Fund offers a unique annual service project to benefit brother Scouts around the world.



The World Friendship Fund of the Boy Scouts of America was developed during the closing days of World War II. At the time, there was a great need to rebuild Scouting in those nations that had been wracked by war and were just emerging from the shadows of totalitarianism.

In the years that have elapsed, virtually every nation in the free world that has Scouting has been aided by the fund. Both those nations that have had Scouting before and those newly emerging nations that desire the Scouting program for their youth have been helped.

Through the World Friendship Fund, voluntary contributions of Scouts and leaders are transformed into cooperative projects that help Scouting associations in other countries to strengthen and extend their Scouting programs.

Types of projects supported by the World Friendship Fund include supporting community development projects in Uruguay and Bolivia; providing funds for eastern European nations to help reorganize Scouting, funding the production of the Russian Scout handbook and providing adult leader training for Scout leaders attending seminars in Geneva, Switzerland.

Additional projects supported by the World Friendship Fund have included: shipment of uniform shirts to Croatian Scouts; Russian Scout leader training; printing of materials for the Boy Scouts of Zimbabwe; scholarships for the World Jamboree; and support for Scouting in Micronesia, Kenya, Mexico and Siberia.

Unit and individual contributions for the World Friendship Fund should be submitted to the Council Service Center where they will be forwarded directly to the International Division, B. S. A.

Since the beginning of the World Friendship Fund, more than \$1 million has been voluntarily donated by American Scouts and leaders to these self-help activities.

# FIESTA!!

## FEBRUARY 2004

### Cubmaster Corner - World Friendship Fund

#### Worldwide Principles

- ◆ Duty to God and respect for individual beliefs
- ◆ Loyalty to one's country and respect for its laws
- ◆ Strength of world friendship and Scouting brotherhood
- ◆ Service to others-community development
- ◆ Universal regard for the Scout Promise and Law as a life guide
- ◆ Voluntary membership
- ◆ Service by volunteer leaders
- ◆ Independence from political influence and control
- ◆ Training youth in responsible citizenship, physical and mental development, and character guidance through use of the patrol system, group activity, recognition through awards, and learning by doing
- ◆ Outdoor program orientation

#### Universal Practices

These acts and symbols of Scouting are familiar all over the world:

- ◆ Scout Promise and Law-duty to God and country
- ◆ Design of badge-basic trefoil
- ◆ "Be Prepared" motto
- ◆ Universal three-finger Scout sign-sign of personal honor
- ◆ Scout left handclasp
- ◆ Use of the patrol system
- ◆ Basic ideal of the Good Turn

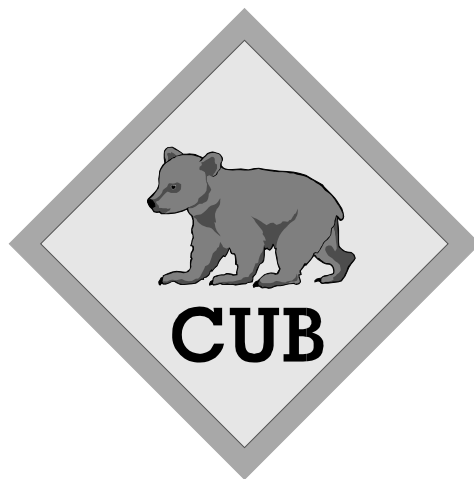

# WALK IN MY SHOES

## March 2004

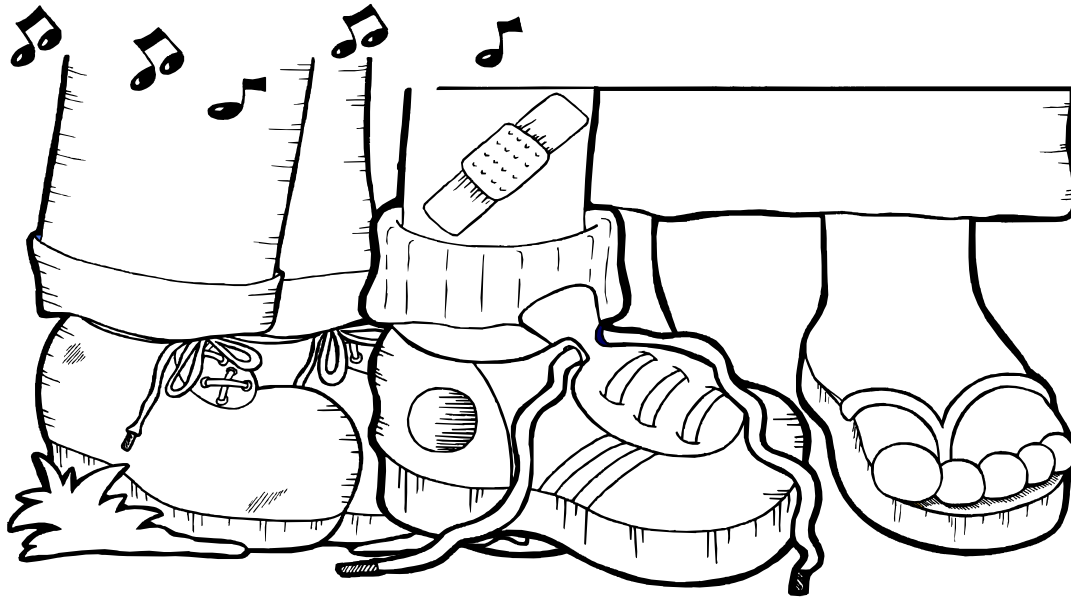

Try putting yourself in another's shoes! Cub Scouts will spend this month exploring the world and experiences of those who face challenges every day, challenges ranging from language and cultural differences to special physical or mental needs. By doing so, our Cub Scouts will become more aware of the diversity in God's children. Cub Scouts can learn sign language or learn to sing the Cub Scout Promise or a song. You may choose to focus on one special challenge or need at each den meeting and bring various aids to underscore the themes, such as crutches, wheelchair, signs or posters printed in other languages, ear plugs or blindfolds. Cub Scouts may even want to create and run a disabilities awareness course at the pack meeting where boys can complete specific tasks at each station without the benefit of one or more senses.

Cub Scout Theme .....	03
Webelos – Athlete.....	17
Webelos – Engineer .....	22
Tigers - Let's Go Outdoors .....	24
Cubmaster Corner – Pizzazz .....	26



# WALK IN MY SHOES

## March 2004

### Resignation Letter

I am hereby officially tendering my resignation as an adult. I have decided I would like to accept the responsibilities of an 8 year old again.

I want to go to McDonald's and think that it's a four star restaurant. I want to sail sticks across a fresh mud puddle and make ripples with rocks.

I want to think M&Ms are better than money because you can eat them.

I want to lie under a big oak tree and run a lemonade stand with my friends on a hot summer's day.

I want to return to a time when life was simple. When all you knew were colors, multiplication tables, and nursery rhymes, but that didn't bother you, because you didn't know what you didn't know and you didn't care. All you knew was to be happy because you were blissfully unaware of all the things that should make you worried or upset.

I want to think the world is fair. That everyone is honest and good.

I want to believe that anything is possible.

I want to be oblivious to the complexities of life and be overly excited by the little things again.

I want to live simple again. I don't want my day to consist of computer crashes, mountains of paperwork, depressing news, how to survive more days in the month than there is money in the bank, doctor bills, gossip, illness, and loss of loved ones. I want to believe in the power of smiles, hugs, a kind word, truth, justice, peace, dreams, the imagination, mankind, and making angels in the snow.

So....here's my checkbook and my car-keys, my credit card bills and my 401K statements. I am officially resigning from adulthood And if you want to discuss this further, you'll have to catch me first, cause, "Tag! You're it."

*From Circle Ten Council, Author unknown*



# WALK IN MY SHOES

## March 2004

### Gathering Activities

#### LANGUAGE DIFFERENCES

How many words can you match up between the English that is spoken in America and the English that is spoken in the United Kingdom, Australia, New Zealand and South Africa? Draw a line to each match.

#### AMERICAN ENGLISH

1. Apartment
2. Automobile
3. Baby crib
4. Bangs (hair)
5. Bath robe
6. Blinkers, turn signals
7. Buddy (friend)
8. Candy Bar
9. Cookie
10. Cross walk
11. Dessert
12. Diaper
13. Dress
14. Emergency room
15. Fire Department
16. Flashlight
17. French Fries
18. Garbage man
19. Good bye
20. Mail
21. Moving truck
22. Nurse
23. Oatmeal
24. Pacifier (Baby)
25. Policeman
26. Popsicle
27. Radio
28. Restroom
29. Saran Wrap
30. Sneakers
31. Soda
32. Suspenders
33. TV
34. Tired
35. Truck

#### QUEENS ENGLISH

- Lorry
- Telly
- Colddrink
- Cling film
- Wireless
- Bobby
- Porridge
- Removal van
- Cheerio
- Chips
- Fire Brigade
- Frock
- Pudding
- Biscuit
- Mate
- Dressing gown
- Cot
- Flat
- Knackered
- Braces
- Trainers
- Water Closet
- Ice Lolly
- Dummy
- Sister
- Post
- Dustman
- Torch
- Casualty
- Nappy
- Zebra Crossing
- Chocolate bar
- Flickers
- Fringe
- Motor car

ANSWERS: 1.Flat, 2.Motor car, 3.Cot, 4.Fringe, 5.Dressing gown, 6.Flickers, 7.Mate, 8.Chocolate bar, 9.Biscuit, 10.Zebra crossing, 11.Pudding, 12.Nappy, 13.Frock, 14.Casualty, 15.Fire brigade, 16.Torch, 17.Chips, 18.Dustman, 19.Cheerio, 20.Post, 21.Removal van, 22.Sister, 23.Porridge, 24.Dummy, 25.Bobby, 26.Ice Lolly, 27.Wireless, 28.Water closet, 29.Cling film, 30.Trainers, 31.Colddrink, 32.Braces, 33.Telly, 34.Knackered, 35.Lorry

# WALK IN MY SHOES

## March 2004

### Openings

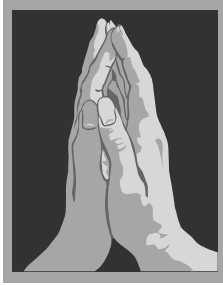

#### PACK PRAYER

Dear Lord we hope that Scouting and our different cultures and those values which we hold most dear - - language - respect - skills - abilities - health - wisdom - justice - will have played a role in equipping our boys to be tomorrow's leaders. we hope that today's children will be tomorrow's leaders, who will be able to usefully apply the knowledge and skills learned during their Scouting experience, and who will be able to appreciate the cultural experiences acquired through Cub Scout Pack \_\_\_\_\_. Amen

#### U ARE IMPORTANT

Cub 1: We cannot spell: C\_B SCO\_TS without U

Cub 2: We cannot spell: YO\_TH without U

Cub 3: We cannot spell: AD\_LT without U

Cub 4: We cannot spell: S\_CCESS without U

Cub 5: We cannot spell: F\_N without U

Cub 6: We cannot spell: O\_TDOORS without U

All: Clearly, Scouting needs U!

#### SAVE OUR WORLD, SHARE OUR CULTURE

Each Cub holds a poster with his letter on one aide and his part written on the other if needed. For a boy who may be to shy to speak or who's handicap may not allow him to speak. They can hold up the "&" poster and all the boys can say together "and. " If available boys could also be dressed in the traditional costumes of their cultures.

S Scouting brings all together.

A Adults help to teach us tolerance.

V Vision a world were we all care.

E Excitement and joy would fill the air.

& And

S Scouting makes us think about each other.

H Hoping our differences help us not hinder.

A Adults teach us to face challenges each day.

R Right and wrong we know the way.

E Each of us can make a difference.

ALL Peace can come to all of us, if we share our cultures and respect each other.  
Will everyone please stand for the Pledge of Allegiances.



# WALK IN MY SHOES

## March 2004

### Den Activities

#### THINGS TO DISCUSS WITH THE BOYS

##### Tips On Ways To Help The Handicapped

Offer help when it looks as though it might be needed but do not insist on it if the individual refuses aid.

Don't "hover". Handicapped people do not wish to be treated as babies. Children react the same way. They want to be like you and me.

When a handicapped person falls, take it easy. Wait for them to give you a cue. If he can get up by himself, he may prefer doing that. If he needs a lift he will tell you which is the easiest way to get him back on his feet.

Crutches and wheelchairs are necessary accessories. Don't take them away from the handicapped person unless he indicated he would like to have them out of the way. Nothing is more irritating than to have your crutches grabbed quickly as soon as you hit the chair, leaving you stranded.

Vehicles are difficult even for the young and agile. The handicapped often need help here, again, let them tell you how to help. Those who do not need to be carried up the steps usually have methods of their own for making them. Do not pull an arm or push from behind unless such assistance has been requested. Precarious balance can be lost entirely with such tactics.

Relax. No matter what you do, if you are friendly and kind, the handicapped person is going to like you.

Have fun. Talk about the same things you would with any other person. A physical handicap does not necessarily limit your interests or dampen your sense of humor.

Be yourself. Don't be sticky sweet. Omit the pious note.

Let common sense and consideration be your guide, and you will never err seriously. The disabled are just like you are, only with a physical difference that does not have to make them feel or think differently.

When in doubt ask - "May I help you?" "How can I help?"

Remember that it is a whole person that we are dealing with.

#### **What You've Wanted To Know About Helping Someone In A Wheelchair, But Were Afraid to Ask!**

In order to ensure the safety and the comfort of physically disabled people and non-physically disabled people when they are together, it is important to remember the following:

*(Provide a wheelchair and let the boys practice the correct way to handle a wheelchair by being the one who is physically challenged and non disabled. This will help to give them an understanding of what it is like to be wheelchair bound.)*



# WALK IN MY SHOES

## March 2004

### Den Activities

#### **What You've Wanted To Know About Helping Someone In A Wheelchair, But Were Afraid to Ask! Continued**

Find out the mechanics of the wheelchair.

Before you start pushing a person in a wheelchair, check for anything caught in the wheels - coats, blankets, scarves, hands, etc.

Check to see if the brake is off because a fast start with the brakes could jar the person right out of the wheelchair.

It is better to back down an incline or curb so the chair does not run away from you. To support it so it does not come down quickly, avoid pushing against the back of the chair because that is the person's back.

If you are going up one small step, tip the front wheels and move up. If there is more than one step go backwards.

If you must go up a flight of stairs with a person in a wheelchair, make sure you have adequate help; one person behind and two people on each side. Grab the chair where it is secure, where no parts will come off. For example, sometimes arms will pull off the chair in order to facilitate transferring.

To go through a swinging door: if the door swings in, push it open with your seat and pull the chair in backwards. If the door swings out, open the door hold and pull, push the wheelchair through.

Don't try and take the chair through loose sand, gravel, ice and snow. If it is necessary to go on rough ground, you may need to go slowly or quickly depending on conditions. Sometimes if you tip the chair on its rear wheels, it makes it easier.

When you are entering and exiting from an elevator, check to see that the elevator and floor are level - avoid bumps.

Be careful of elevator doors, some close very quickly.

You cannot usually turn a wheelchair in an elevator, so enter and exit the same way.

Wheelchair people don't like crowded elevators. They are smothered and claustrophobic. Wait for another.

While walking with a person in a wheelchair, be aware of the person and what he/she is interested in. If you are walking in a crowd, it is difficult to hear so keep in touch, lean over, make comments, see if there is any place that the person would like to go.



# WALK IN MY SHOES

## March 2004

### Den Activities

#### **What You've Wanted To Know About Helping Someone In A Wheelchair, But Were Afraid to Ask! Continued**

Most people in wheelchairs don't like to go into the middle of a crowd. Skirt it. Remember the level you are at. It is full of noise, dust, dirt, kids, shopping bags, dogs, etc. This can be very claustrophobic, so be aware of the feeling.

If you want to talk to a person in a wheelchair, go somewhere where you can sit so that eye level is equal. Looking up is difficult and tiring. If it is impossible to sit down, stoop over, bend over or move a few steps away from the wheelchair, so that the back of the neck does not have to be held back for long periods of time.

Be aware of eye level for viewing. Just because you can see doesn't mean the person in a wheelchair can. Often bars, railings, block the vision. Bend down to their eye level and check out what they can see.

The person in a wheelchair has fears about whether the volunteer can handle the chair, so avoid dangerous positions; e.g. stairs, inclines and ramps. If you must stop at the top of the stairs, turn the chair sideways so that if the chair is bumped it won't go down, and put the brakes on.

If you are helping a person to stand up, give him a waiting time so their body can adjust to the new position. Don't let go until they say they are ready.



Check with the person on canes and crutches before you assist them. A too helpful arm can throw them off balance.

A person in a wheelchair is not an object sitting in a chair; it is a person. However, sometimes the person with a disability is the object of curiosity. Be aware of it. Don't panic yourself. Try to treat the situation as honestly as possible. Don't pretend the disability is not there.

Remember pride and self-dignity all the time. Let a person with a disability do his/her own inquiring whenever possible.

The person is the authority on his/her disability. Ask them the best way to help and work out a system so you are both comfortable. Keep dignity and safety in mind at all times.

#### **When You Meet a Blind Person**

Treat a blind person as you would anyone else. He does the same things as you, but sometimes uses different techniques.

If you are not sure how much a blind person sees, ask. Not all blind people have total absence of sight. Most have some sight and make the best use of what vision remains.

Speak to a blind or visually impaired person in a normal tone of voice. Identify yourself and let him know you are addressing him by using his name or touching his arm. Be sure to indicate when you are leaving.

# WALK IN MY SHOES

## March 2004

### Den Activities



#### When You Meet a Blind Person Continued

When walking with a visually impaired person, let him take your arm if he wishes. Pulling him by the hand is awkward and confusing.

Do not hesitate to use words like "see", "look", or "read". A blind person will use such words in his vocabulary as often as anyone else.

Describe your surroundings, whether it is the scenery from a moving car, an interesting incident on TV. or the layout of an unfamiliar room.

Give directions clearly and accurately. Pointing or using phrases such as "over there" will be of no assistance.

Never distract a dog guiding a blind person. The dog guide is responsible for the safety of its master and such interference could lead to unnecessary tragedy.

Avoid the impulse to rush to a blind person's aid. If you are not sure whether or not he needs your assistance, ask.

Remember, when you meet a blind person, common sense and courtesy can lead to an enjoyable friendship.

*After going over these tips have a trust walk with have the boys blindfolded and the others leading based on what they have learned. Then have them switch places.*

# WALK IN MY SHOES

## March 2004

### Den Activities

#### **INTERNATIONAL ACTIVITY PATCH**

The International Activity Patch (No. 1440) is a 3-inch embroidered emblem worn as a temporary patch centered on the right pocket of the uniform shirt. It can be earned by Cub Scouts, Boy Scouts, Varsity Scouts, Venture Scouts and Scouters who participate in an international activity or program defined by local council.



Units have the opportunity to develop activities that meet requirements for the International Activity Patch! Planned activities may be approved by Council through a Unit's District Executive.

*Each local Council has the authority to determine requirements for the patch. There is no time restriction for earning the International activity patch.*

Here are some examples of the criteria, which can be established for this patch:

#### **General Requirements for Cub Scouts:**

An international activity is an activity where boys learn about at least one other country in depth; including its customs, songs, games, and costumes. The activity should meet requirements for achievements and electives in the Cub Scout books. Also, the activity should help foster the "World Brotherhood" attitude of Scouting in both boys and leaders.

#### **In a Pack:**

An International activity that provides an **in depth experience** of one country. (E.g. Customs, flag, food, costumes music, games, etc.)

An International activity that provides an opportunity of learning about several countries in detail.

A Blue and Gold Banquet that centers around an International theme and uses ideas from one or more foreign countries. Ceremonies and other activities of event should have a flavor of "World Brotherhood".

A Scout-o-Rama booth where an International theme is developed. This booth could be centered around one country or several countries and should include flags and costumes. Games from other countries work well in this event.

#### **In a Den or Family:**

A four week International activity that develops an experience of one country. For example: first week they learn about the flag and songs, second week they prepare food, third week they do a craft activity, and fourth week they play games.

A four week International activity that develops an experience where boys learn about several countries. Each week the boys could learn about a different country.

#### **NOTE:**

An individual may earn the patch if he/she participates in any scout meeting that is held in another country.

A family may earn the patch if they host Scouts or Scouters from another country in their home. At least one overnight stay would be necessary



# WALK IN MY SHOES

## March 2004

### Songs



#### CUB SCOUT PRAYER

(Tune: O Tannenbaum)

Lord, in this evening hour I pray,  
For strength to do my best each day.

Draw near to me that I may see,  
The kind of Cub that I should be.

In serving other, let me see,

That I am only serving Thee.

Bless me, Oh Lord, in Thy great love,

That I may be a better Cub.

--Southeastern Massachusetts Cluster Council  
Pow Wow 1997

#### THAT'S WHY WE ARE IN CUB SCOUTS

(Tune: Deep In The Heart Of Texas)

The fun things in life,  
Our family's delight!  
(clap hands four times)  
That's why we're in Cub Scouting.

We do our best,  
To pass each test  
(clap hands four times)  
That's why we're in Cub Scouting.

Just me and my son,  
Work, play and have fun,  
(clap hands four times)  
That's why we're in Cub Scouting.

We think our pack's great,  
We keep it first-rate;  
(clap hands four times)  
That's why we're in Cub Scouting!  
Bay Area Council Pow Wow, 1994

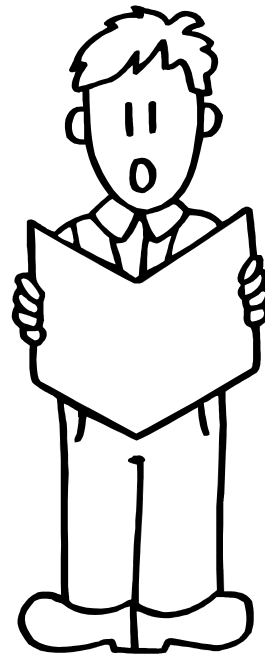

#### I AM SPECIAL

(Tune: Frere Jacques)

I am special, I am special  
Yes I am! Yes I Am!

I am very special  
No one else is like me.

I am me! I am me!

Nashua Valley/Pioneer Valley  
Pow Wow 1996



# WALK IN MY SHOES

## March 2004

### Skits

#### WE ARE ALL ALIKE, WE ARE CUB SCOUTS

Have the boy's list different ways that they have seen others being treated unfairly because of their physical challenge. Then have them give ways to correct the situation. Take three or four of those ideas and let the boys role play the situation for the entire pack. In this way they have the opportunity to share with the entire pack and help to develop empathy for the challenges experienced by others.



#### MAKING A CUB SCOUT

##### CHARACTERS:

*Child*

*Two Leaders*

*Two Parents*

**PROPS:** You will need a large table for the child to lie on during the "operation." The "doctor" can carry a large cardboard knife. Props to be "removed" are tacked to back of table, out of sight. Those to be "put in" can be placed nearby. (Props are listed where used.)

**NARRATOR:** We are about to instruct you in the method of making a Cub Scout. To complete this project, you will need one small eager boy, two interested parents, one patient Den Leader, and one courageous Cubmaster.

(Each character enters as his name is spoken. Boy wears uniform under a large loose-fitting shirt and climbs up on the table. Others don surgical masks. As the narrator continues, the operation proceeds, with Cubmaster acting as doctor. Den Leader and parents hand him the things to be put in and take the things removed. When the boy is hidden under a sheet, he removes his shirt.)

**NARRATOR:** Cover him with fun and good times  
(Hold up posters labeled "FUN" and "GOOD TIMES" and cover boy)

We use laughing gas for anesthetic.

(Use a tire pump labeled "Laughing Gas.")

Take out hate and put in Love.

(Hate - lump of paper, so labeled. Love - big paper heart, labeled).

Take out selfishness, put in cooperation.

(Sign "I," sign "WE).

Take out idle hands, put in busy fingers.

(Idle - empty rubber gloves. Busy - glove full of flour.)

Take out laziness, put in ambition.

(Laziness - rag; Ambition - blown up balloon.)

After this pleasant operation, we have a "CUB SCOUT."

(Remove the sheet. Boy, in uniform, stands up and gives the Cub Scout sign.)

Long Rivers Council Pow Wow 1992

# WALK IN MY SHOES

## March 2004

### Games

#### BALLOON BLOWOUTS

*Balloon Blowout where some players are blindfolded and given a partner, verbally and physically guiding them, to simulate a blind person playing.*

**EQUIPMENT:**

*Balloons of four different colors  
8 pylons  
Badminton rackets.*

**OBJECTIVE:**

Put all four of your balloons in each goal, one in each goal.

**DESCRIPTION:**

Divide into four teams. The playing area is a large square. A goal for each team is made on each side of the square. At the center is a pile of balloons. The balloons of the color assigned to your team must go in each goal. Balloons are moved using the badminton rackets.

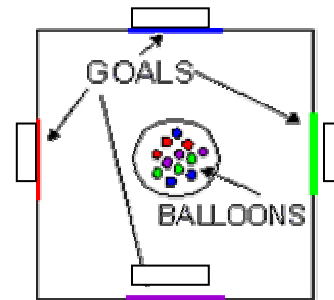

#### WHEELCHAIR BUDDY RELAY

**EQUIPMENT:**

*Wheelchairs  
Anything to create obstacles*

**OBJECTIVE:**

To be the first team to complete the relay.

**DESCRIPTION:**

The group is divided into two teams. Within each team, find a partner. One of the partners will be seated in wheelchair. The other will direct the wheel chair bound through the maze without touching the obstacles. First team through wins.

#### PARTNER SHOE SCRAMBLE

Have all the boys put their shoes in a pile 20 feet away from the starting line. Mix up the shoes so that no pairs are together. Divide into two teams On signal, the first boy: Runs to the pile picks out their shoes race back to the starting line carrying their shoes then put their shoes back on. Once he has put his shoes on he goes to the back of the line and the next boy goes. The first team to finish wins.

#### SHOEBOX RELAY

Provide each relay team a pair of empty shoeboxes. On signal, one player from each team places his feet in the boxes and shuffles to the goal line and back. Make sure the adults participate too!

#### WALK IN MY SHOES RACE

Really, really, really big gum boots or galoshes.

Divide the boys into two teams. Have them take off their shoes and stand in two lines. Place the huge boots at the starting line and have the boys put on the "boots" race down to a turn-around point and return to give the boots to the next in line.

# WALK IN MY SHOES

## March 2004

### Advancement Ceremonies

#### CRACKER JACK

Show the boys a box of cracker jacks. Inside you will find a prize. Draw each of the boys awards from the box. Let the parents pin the awards to their sons uniform. After all the awards have been handed out say the following to the boys.

The label says that the prize is inside. I really think that the prize is on the outside. Why? The prize in life when you go outside of your own box or comfort zone. Sometimes going out of your way for others is the only way to really help others and feel accomplished in what you do.

This month we have learned how to help others and be aware of others differences. I hope that we will always think of others and how they would feel about the things we say or the actions we do. So thinking "This is the way we have always have done it" doesn't cut it any more. As Scouts, parents, and a community we can change the intolerance in the world today.

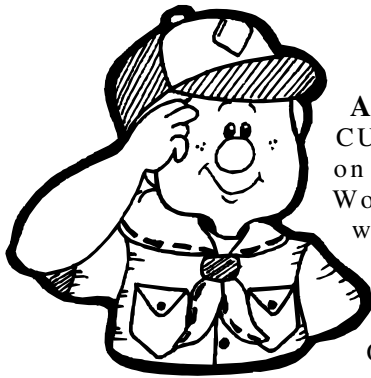

#### ACTING PARTS IN LIFE

CUBMASTER: Tonight we would like to congratulate the pack on the advancements they have made over the last month. Would the following boys \_\_\_\_\_ please come forward with their parents to be presented with their award. After presenting the boys with their advancement say the following:

Our lives are made up of many different acts or parts. As young boys, you act the part of a Webelos, or a Cub. In school you act the part of a student. At home you act the part of a son. Whatever part you act, do what is right and do your best so you too someday may be a good parent and a good citizen just like all the adults around you today. Continue to advance and learn as you enjoy your Scouting program.

# WALK IN MY SHOES

## March 2004

### Run On/ Applause

What do you give an elephant with big feet? Plenty of room  
What wears shoes but does not walk? A footpath  
How does a tennis player sneeze? A-tennis-shoe! A-tennis-shoe!  
What has one foot and four legs? A bed  
What do bears and wolves get when they walk along the beach?  
Sandy Claws!  
Why don't bears wear shoes? So they can go BEAR-foot.

### DEN YELLS

North, South,  
East or West  
Den \_\_\_  
Is the Best!

Show us some action!  
Show us some spark!  
All for Den \_\_\_  
Stand up and bark.

United we stand  
Divided we fall  
Den\_\_\_\_\_is the best of\_all

We've done fine!  
We've done well  
Now for an ear splitting yell  
Den\_\_\_\_Den\_Den\_\_\_



# WALK IN MY SHOES

## March 2004

### Closings

#### I'M A BOY

- 1<sup>st</sup> Cub: Everyone cannot be brilliant, everyone cannot be smart. I may not be a genius, but I can build a neat go-cart.
- 2<sup>nd</sup> Cub: I can dam a stream with boulders, I can climb trees to the top. I can run for blocks and blocks and never even stop.
- 3<sup>rd</sup> Cub: I can't solve a chemical equation or lecture on Newton's rule, but I can make a peanut butter sandwich that will really make you drool.
- 4<sup>th</sup> Cub: I don't know much about flowers, but smelling them is a joy. I don't think I'm a failure. I'm a genius at being a boy.

#### Cubmaster Minute

As the nineteenth century ended, men on both sides of the Atlantic worried about boys, especially poor immigrant boys in the teeming cities, who seemed destined for delinquency or poverty. Ernest Thompson Seton, a Canadian naturalist, wildlife painter, and children's author, summed up these anxieties: "It is the exception when we see a boy respectful of his superiors and obedient to his parents, handy with tools and capable of taking care of himself, under all circumstances whose life is absolutely governed by the safe old moral standards." Seton looked around for "robust, manly, self-reliant boyhood," and found instead "a lot of flat-chested cigarette smokers, with shaky nerves and a doubtful vitality"—just as his British contemporaries found an alarming number of young men unfit for the draft.

These concerned men responded by creating a host of character-building organizations, the most powerful of which was the Boy Scouts. The organization grew out of Seton's newly created boys' group, the Woodcraft Indians, and the insights of an ebullient British war hero, Robert Baden-Powell. Lord Baden-Powell had returned to England from the Boer War in 1903 to find children devouring a soldier's scouting manual he had written. Teachers urged him to revise the manual for boys, and Baden-Powell, inspired by Seton's Woodcraft Indians handbook, seized the challenge.

He envisioned a new organization that would draw on wartime scouting lore and ancient codes of chivalry to teach boys the Victorian virtues. King Arthur's Round Table, Baden-Powell understood, resonated in boys' souls, for it symbolized the marriage of strength and goodness, by contrast with today's "gangsta" culture, which defines manliness as violently predatory. The aim of this new organization, Baden-Powell wrote in 1906, "is to develop among boys a power of sympathizing with others, and a spirit of self-sacrifice and patriotism."

Baden-Powell believed that Scouting's core virtues of selflessness and the cheerful performance of duty were as valid for the poor as for the upper and middle classes. "Everything on two legs that calls itself a boy has God in him," he insisted, "although he may—through the artificial environment of modern civilization—be the most arrant little thief, liar, and filth-monger. Our job is to give him a chance." Respect for others, without class distinctions, was a scout's universal duty.

We are taught tolerance for others, respect for our difference, compassion for those less fortunate. We all walk in the same shoes. Those of a Scout and a Scouter. May we always remember to treat each other with goodwill. Goodnight.

# WALK IN MY SHOES

## March 2004

### After the Meeting

#### ALL AMERICAN SNACK

Amount	Measure	Ingredient
3	cups	thin pretzel sticks
4	cups	wheat chex®
4	cups	cheerios®
1	13 ounces	salted peanuts
1	teaspoon	garlic salt
1	teaspoon	celery salt
1/2	teaspoon	seasoned salt
2	tablespoons	grated parmesan cheese
1/4	cup	melted butter

#### Preparation:

In large mixing bowl or slow-cooking pot, mix together pretzels, cereals, and peanuts. Sprinkle with garlic salt, celery salt, seasoned salt, and cheese. Pour melted butter over all; toss until well mixed. Cover and cook in slow-cooking pot on low 3 to 4 hours. Uncover the last 30 to 40 minutes. Serve as appetizer or snack.

#### EAST INDIAN SNACK

Amount	Measure	Ingredient
1	5 ounces can	crisp Chinese noodles
1	6 1/4 ounces	salted cashew nuts
2	cups	rice chex®
1/8	cup	toasted coconut
1	teaspoon	curry powder
1/4	teaspoon	ground ginger
1/4	cup	melted butter
1	tablespoon	soy sauce

#### Preparation:

In mixing bowl or slow-cooking pot, mix together noodles, cashews, Rice Chex, and coconut. Sprinkle with curry and ginger. Add butter and soy sauce. Toss until well mixed. Cover and cook in slow-cooking pot on low 3 to 4 hours. Uncover the last 30 to 40 minutes. Serve as appetizer or snack.

#### MEXICAN CHEX MIX

Amount	Measure	Ingredient
1 bag (3.5 ounces)		Betty Crocker Pop Secret butter-flavored microwave popcorn
8	cups	Corn Chex cereal
4	cups	corn chips
2	cups bite-size	cheese crackers
3	tablespoons	margarine or butter, melted
1	teaspoon	chili powder
1/3	cup	grated Parmesan cheese
1/4	cup	Bac O's bacon-flavored bits or chips, if desired

#### Preparation:

Microwave popcorn as directed on bag. 2. Mix cereal, corn chips and crackers in 2-gallon resealable plastic food-storage bag. Shake popcorn into cereal mixture, being careful not to add unpopped kernels. Drizzle with margarine. Shake to coat mixture. 3. Add remaining ingredients. Shake gently to blend all ingredients.

# WALK IN MY SHOES

## March 2004

### Athlete

#### BEING HEALTHY

By Barb Stephens

#### Good Health Habits

Circle the correct answer(s).

Bathe/shower (every/day OR 1/week) and especially after exercise.

Wash your hair (1/month OR 2+ times/week).

Wash hands (before eating OR after using the restroom) and when they're dirty.

Eat right - (3 OR 4 OR 6) regular meals each day at regular times!

Eat (just some OR a variety of) food from each of the 4 food groups.

The average 10 year old should get at least (6 OR 9 OR 12) hours of sleep each night.

ANSWERS: Everyday, 2+ times, before eating and after using restroom, 3 meals, Variety, 9 hours



#### Clean & Strong

Circle T for True or F for False.

- T F 1. Our bodies "repair" themselves while we sleep.
- T F 2. Clean clothes aren't necessary after a bath or shower - they are just in the morning.
- T F 3. Use proper lighting for all activities including reading, TV viewing, and playing.
- T F 4. Fitness is never just physical - it involves both the mind and body together.
- T F 5. Stand tall, and walk tall with shoulders back and stomach in.
- T F 6. It's OK to share drinking cups, washcloths and towels.
- T F 7. Different foods provide different nutrients, and no one food can sustain us.
- T F 8. Rushing meals or skipping meals can be harmful to your body.

ANSWER: 1 - T, 2 - F, 3 - T, 4 - T, 5 - T, 6 - F, 7 - T, 8 - T



# WALK IN MY SHOES

March 2004

Athlete

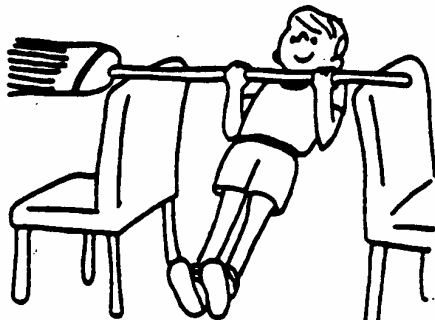

PULL-UPS

MAKE HOME-MADE BARBELLS FROM A BROOMSTICK AND TWO STRONG CLOTH SACKS (OR PILLOWCASES). FILL EACH SACK WITH FIVE POUNDS OF SAND OR GRAVEL. WRAP THE HANDLES OF THE SACKS AROUND THE BROOMSTICK, ABOUT FOUR INCHES FROM THE ENDS. TIE IN PLACE.

THE PRONE PRESS EXERCISE HELPS DEVELOP THE CHEST  
THE STANDING PRESS HELPS INCREASE THE STRENGTH IN THE ARMS.

STANDING PRESS

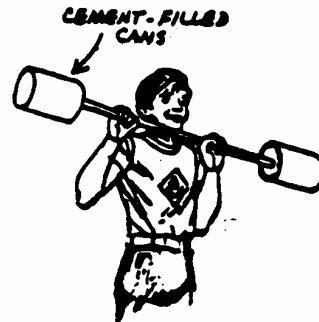
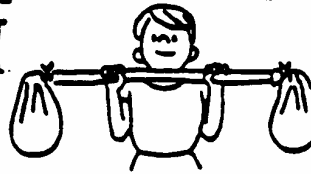

CEMENT-FILLED CANS

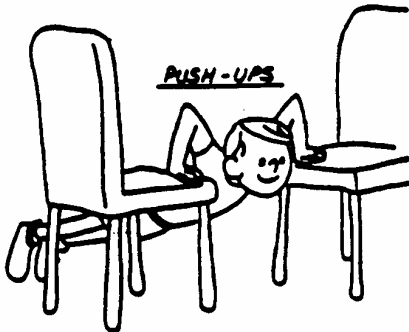

PUSH-UPS

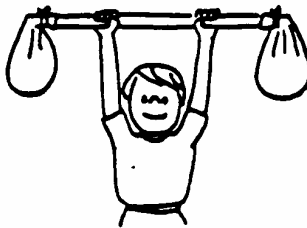

PRONE PRESS

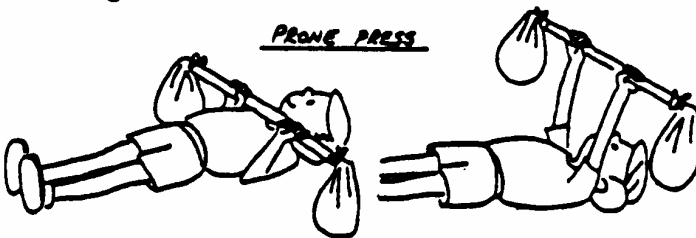

TIN-CAN WALKERS MADE FROM 2-LB. COFFEE CANS AND SHORT LENGTHS OF ROPE. FRACTURE THE CANS ON OPPOSITE SIDES JUST BELOW CLOSED ENDS. THREAD A LENGTH OF CLOTHES-LINE THROUGH THE HOLES AND TIE THE ENDS TOGETHER SO THE LOOP REACHES SLIGHTLY ABOVE YOUR KNEES WHEN YOU STAND ON THE CANS. WALK 25 FEET AND RETURN.

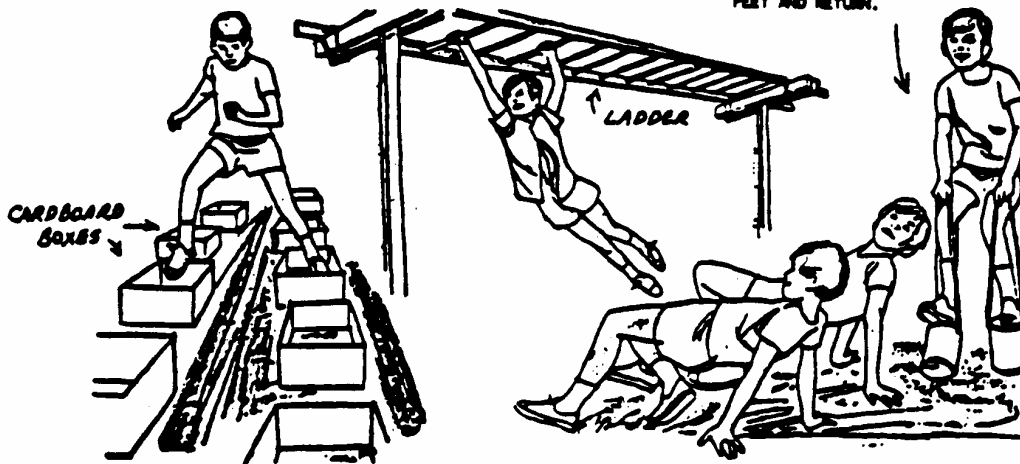

CARDBOARD BOXES

LADDER

# WALK IN MY SHOES

## March 2004

### Athlete

#### Volleyball Serve it Underhand

The underhand serve is the easiest to master for volleyball. In a game you must put the ball into play from a 10 foot wide area behind the end line. Always practice with a line in front of you so you will learn not to cross it until you have released the ball.

For the underhand serve (if right handed), stands with your left foot about 13" in front of the right foot. Bend both knees a little, lift the ball in both hands out in front of your chest, to your right side. Hold the ball in the left hand and start to bring the right hand down. Close the finger of the right hand as if you were making a loose fist.

Keep your eyes on the ball. Bring right hand down, back, and up behind you. Step a

quarter step forward on your left foot. Swing your right hand at ball. Just before you hit it, toss the ball up a little and drop your left hand away from it. (The rules say – release your left hand from the ball before hitting it.) Strike ball solidly with the palm side of your fist and follow through. (Of left handed, reverse from right to left.)

Once you master the serve, try using the heel of hand instead of fist. Close hand instead of your fist. Close your hand half-way so

fingertips come just below the base of the fingers with thumb-tip beside the first joint of forefingers

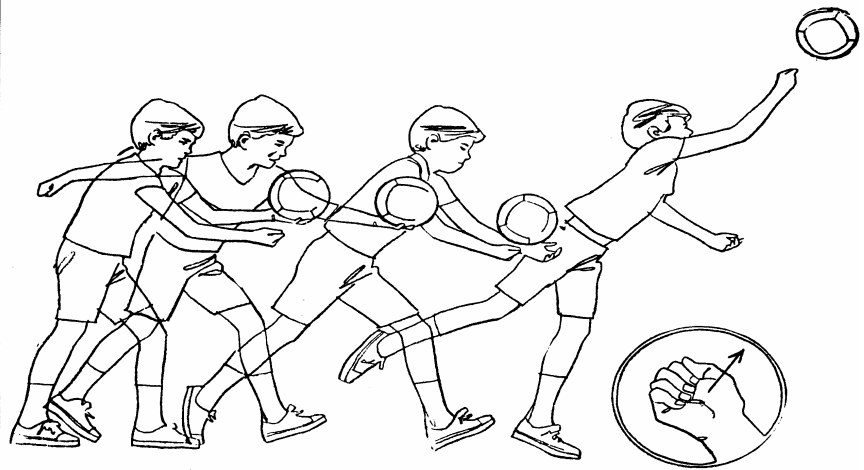

#### THE ATHLETE

Tune: My Bonnie

They gave me a suit and a number  
And sent me out on the field  
They gave me a ball called the pigskin,  
And shoes with some cleats, toe and heel

#### CHORUS

Muscles, Cramps, wracking my body with  
Pain, with pain  
I stand, wondering,  
if ever I'll do this again!

Next time they gave me a racquet,  
Then sent me out on the court  
Funny the things you encounter,  
While trying to learn a new sport.  
(CHORUS)

The ordeal was finally over,  
At least, that's what I thought,  
When they shoved me the soccer  
equipment,  
I fainted dead on the spot!  
(CHORUS)

# WALK IN MY SHOES

## March 2004

Athlete

# BICYCLE GYMKHANA

The word "gymkhana" comes from India by way of England, where it is used to describe an unusual kind of automobile race. Competition is against the clock, and a variety of driving skills are necessary to qualify with the best time. Here is a gymkhana adapted for bicycles. True to the tradition, speed alone will not give the best time. Instead, a mixture of good balance, accuracy, practice, and a well-maintained bike should carry the day.



Lay out a course on a little-used street, parking lot, or other paved area. Chalk, sticks, small stones, tin cans, even poured sand can all be used to mark the course.

This course is only a suggestion. Use it to get started, but by all means, add your own inventions.

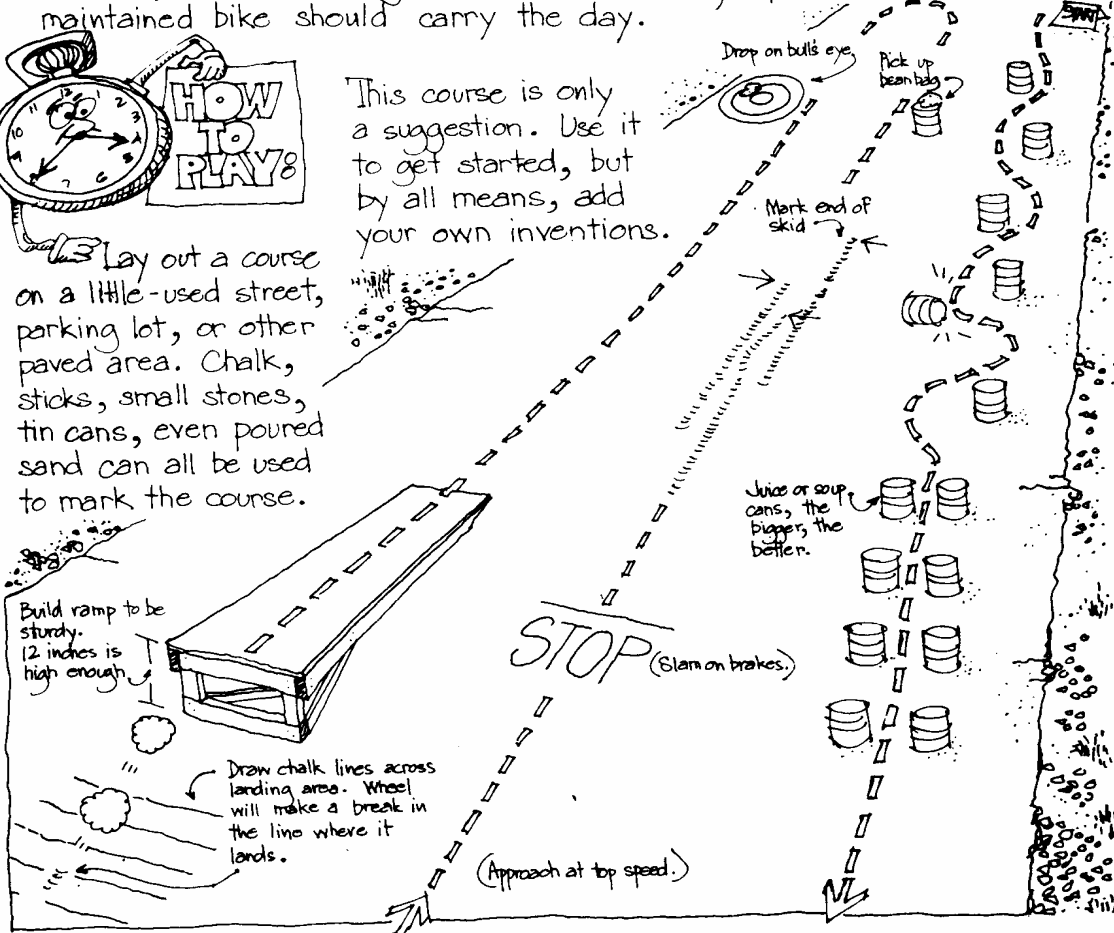

The "winner" is the player who completes the course in the least time... BUT for each can knocked over add 5 seconds. For the shortest stopping time subtract 10 seconds. For the longest jump subtract 10 seconds.

# WALK IN MY SHOES

## March 2004

### Athlete

#### TOWEL PICKUP

Take off your shoes and socks. Pick up a towel with your toes.

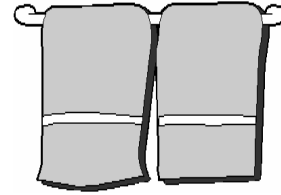

#### PAPER PICKUP

Pick up a piece of paper from the floor without bending your knees

#### BOOK CARRY

Walk across the room with a book balanced on your head.

#### SKIN THE CAT

Clasp your hands in front of you. Try to step through the ring formed by your hands and finish standing upright with them clasped behind you. Return to your original position by stepping backwards through the ring.

#### TOE WRESTLING

Two wrestlers sit on the floor, facing each other with arms clasped around knees. When they are in this position, place a stick over each person's elbows and under his bent knees. Their feet should be flat on the ground with the toes of one touching the toes of his opponent. The object is for one wrestler to get his toes under the toes of his opponent and roll him over backwards. If either wrestler breaks the handclasp above his knees, the other wins the contest.

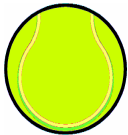

#### SIDEWALK TENNIS

Played with a tennis ball on two squares of sidewalk or patch of level ground marked off in similar size. Ball is batted with the hands. Use regular tennis rules, except that there is no serving court

### SUGGESTIONS FOR COMPLETING ATHLETE ACTIVITY BADGE

#### Requirement #1

Can be combined with the Fitness Activity Badge and the Sportsman Activity Badge. The subjects of being physically healthy, balanced diets, and bad effects of drugs, alcohol, and tobacco can be combined and signed off all together.

#### Requirement #2

Takes the longest amount of time to complete and sign off of all the Physical Skills Group. To earn the Physical Fitness Sports Pin, the boy needs to earn 60 points in a 90 day period. They must exercise or be involved in some activity for 30 minutes to earn one point. The boy can earn a maximum of five points in a day. Just remember 30 minutes for one point, 60 points total in a 90 day period.

You can pass off requirements 3 through 9 as part of this pin, use requirement 3 and 4 of the Sportsman badge to meet the requirement.

# WALK IN MY SHOES

## March 2004

### Engineer

#### MODEL MONKEY BRIDGE

Based on a foot bridge found in the high mountains of India, the monkey bridge uses one thick rope to walk on and two others as hand ropes.

The same design and knots used in the full-sized version are used in this model. The monkey bridge is often built in Scout camp as part of the Pioneering merit badge. You'll need some hemp cord, some pieces of strong string, four 1/4" dowels 10" long, and two 1/4" dowels 4" long. A piece of scrap lumber at least 30" long and 4" wide makes a good base.

Make the shear lashings first, about 4" from the top of the shear legs. Tie loosely so the legs can open. Add the crosspieces, fastened with square lashings about 2" from the bottom. All lashings begin and end with a clove hitch.

Stretch the cord between the supports and tack the ends in place. Add the hand ropes and fasten them to the same anchor. Paint or stain the wood to give the bridge a rustic look.

#### Speakers in the following Fields of Engineering

**Aeronautical Engineering** - deals with the whole field of design, manufacturing, maintenance, testing, and the use of aircraft.

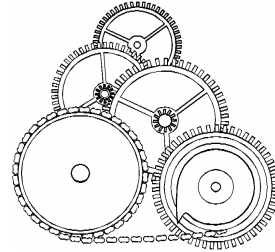

**Industrial or Management Engineering** - pertains to the efficient use of machinery, labor, and raw materials in industrial production.

**Chemical Engineering** - concern with the design, construction, and management of factories in which essential processes consist of chemical reactions.

**Civil Engineering** - is one of the broadest of the engineering fields dealing with the creation improvement and protection of the communal environment. Buildings, roads, bridges, airports and other constructions are just a few of the areas civil engineers impact.

**Electrical Engineering** - involves the use of electrical power, electrical machinery and communication, information, and control systems.

**Geological and Mining Engineering** - includes activities related to the discovery and processing of minerals.

**Mechanical Engineering** - speaks to the design and operation of all types of machinery.  
**Safety Engineering** - is concerned with the prevention of accidents.

# WALK IN MY SHOES

March 2004

## Engineer

### MAKE A STEAM ENGINE

A Webelos Scout may get a graphic demonstration of the power of steam by building the simple steam turbine shown in this illustration. Materials needed are a tin can, a lid from a second tin can, a pair of tin snips, a sheet metal screw, a cork, a power drill, an extra piece of tin to make the support for the turbine wheel, a finishing nail, and a source of heat.

Assemble to look like the illustration.

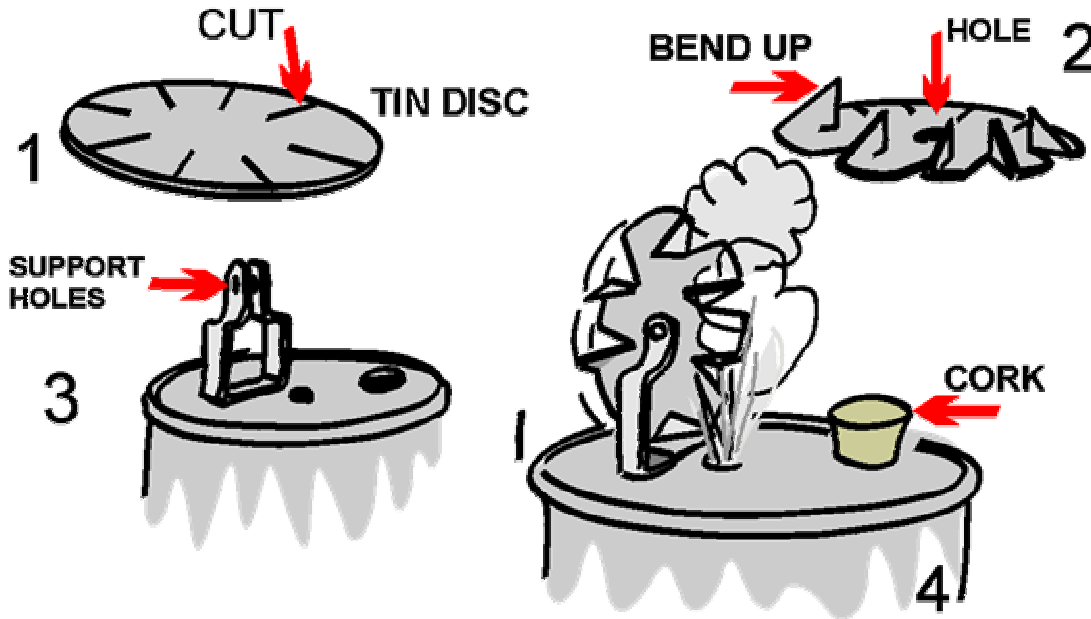

### BLUEPRINT SYMBOLS.

Can be used in floor plans drawn for requirement 8 of the Webelos Engineer activity badge. Make a game of learning them by putting each one on a 3" x 5" card and using them as flash cards.

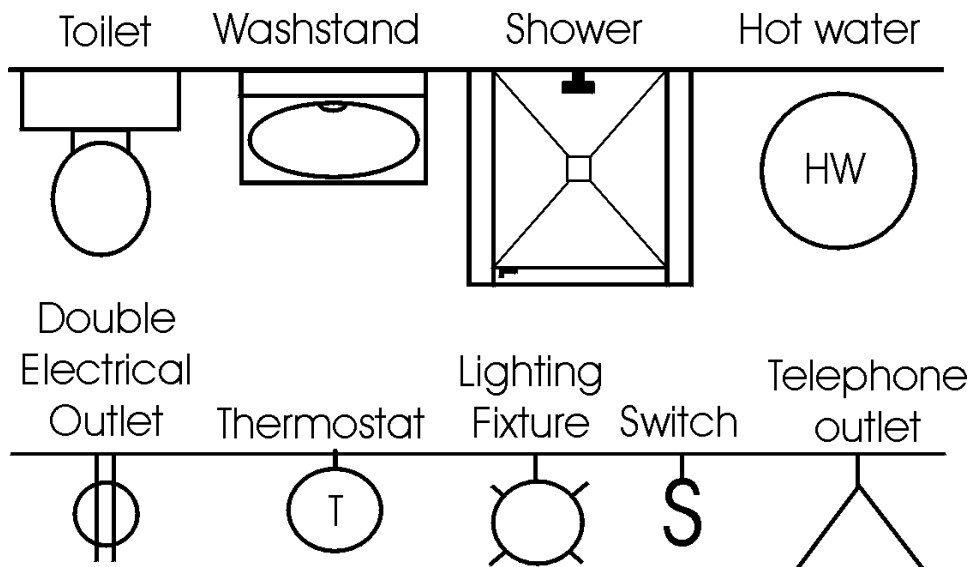

# WALK IN MY SHOES

## March 2004

Tigers - Let's Go Outdoors

Family Activity

Xerox game onto white cardstock. Let boy's color and play with their family. This game is for two players. Cut out the playing pieces. Then roll a dice to determine number of moves.

### Energy-Savers Game

The game board is a large, winding path with several sections. Each section contains an illustration and a text box with instructions. The path starts at a 'Start' box, goes right, then curves down and left, then curves down and right, then curves down and left, and finally ends at a 'Finish' box. The path is divided into sections by lines, and there are cut-out lines at the bottom left.

**Start**  
Take turns rolling a die and moving your marker along the path.

**Power Plant**  
You know that saving energy helps take care of Earth. Go forward 1 space.

**Light Switch**  
You turn out lights when you're not using them. Take another turn.

**Windows**  
You shut windows and curtains when the heat is on. Go forward 3 spaces.

**Boy with Book**  
You ride a bike or walk when you can. Move ahead 1 space.

**Person on Bike**  
When it's cold inside, you put on a sweater to help stay warm. Go to the next space.

**Rechargeable Batteries**  
You use rechargeable batteries in your toys. Move ahead 1 space.

**Recycling**  
You recycle—it helps save energy! Take another turn.

**Finish**  
You must land here by exact count.

Illustrations include: a girl with a globe, a power plant, a hand flipping a light switch, a boy with a book, a person on a bicycle, a sweater, a person with a cart, and recycling bins for Plastic, Cans, and Glass.

# WALK IN MY SHOES

## March 2004

### Tigers - Let's Go Outdoors

#### Den Activity

##### CLOTHEPIN BUGS

Use spring type clothespins. Paint them. Wings are made from construction paper, cut into symmetrical shapes. Slip wings into clothespins jaws and glue. Straight pins with colored round heads can be used for antennae. Bumblebee uses a 1 ½" Styrofoam ball or ping pong ball cut in half and glued to top of clothespin. Pom poms can be used for eyes, paper clips can be used for legs, etc. OPTIONAL: Glue ½" magnetic strip to back of clothespin and make into a refrigerator magnet for mom for Mother's Day.

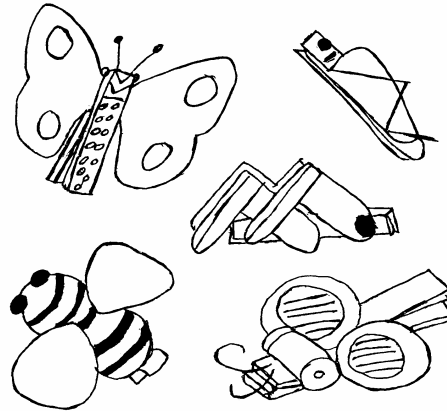

#### GAMES

##### SCORPION'S STING

A tag game in which "it" is the scorpion and walks on his hands and one foot. "It" has to keep the other foot in the air. This is the stinger and "it" tries to tag the other players with his stinger.

##### BUG TUG

Make 2 lines on the ground about 10 feet apart; the two opponents stand back to back between the lines. Both bend forward, reach between their legs and grasp each other's wrists, they then start pulling each other towards their line.

#### Go See It Outing

- Go on a short guided hike at a local nature center.
- Design and conduct a nature scavenger hunt. Show samples of the 3 - 5 items on the list
- Visit your local water treatment plant. What makes the water safe to drink?
- Visit a planetarium. Learn about those stars in the sky. Discuss the aerospace program and how close we are to living up there.
- Go fishing. Release your fish when you are done.
- If possible, visit a trash to energy plant.



# WALK IN MY SHOES

## March 2004

### Cubmaster Corner - Pizzazz

Anyone can hold a Den meeting, go through the crafts and activities and send the kids home. Anyone can hold a Pack meeting, give out the awards and advancement, and send the kid's home. BORING!

It's the Pizzazz that keeps them coming back. It's the songs, skits, stories, run-ons, and cheers that bring on the laughter, the sparkle in the eyes, the excitement. It's the impressive ceremonies when the kids are recognized for achievement, that they will remember for years to come.

Santa Clara Council

#### **Become a Song Leader**

Why songs? Remember the great times singing those songs in school or that song that rumbled the rafters at church? The feeling after these songs really lifted the spirits. Singing is fun! Songs can create enthusiasm or set a mood.

To be a successful song leader, all that is required are a few tips about how to lead songs. Voice? Don't worry about it! A voice like that of a crooner or an operatic star is not necessary. Never apologize. It's easy and it's fun to lead songs. Just follow these hints to be a song leader! A song leader must break the ice, particularly with a new group. Do things that will break down the reserve and get everyone into the group spirit. At the beginning of the first song period, announce that the group will do things together. Ask a Cub Scout to stand in front of the group and throw his neckerchief into the air and then catch it. Have him do this several times. Tell the group that they can yell as long as the neckerchief is in the air, but must stop instantly when the neckerchief is caught. Suggest such words as "yip-pee, wahoo, Akela, Wolf, Bear, Webelos" etc. Everyone should yell something.

#### **TIPS**

1. Begin with a song that everyone knows. Announce the name and the tune (if it isn't an original song).
2. Sing the first few bars, or sing the entire song. This will give the pitch and the proper tempo. If there is a piano and a pianist or a recording of the song, use them to teach the song.
3. Then start the song. How? Tell the group to begin singing after the first few words, then signal, such as a simple down motion with the hands is given.
4. What about hand motions? Start with simple up and down motions. Then use these motions to keep time with the rhythm and the syllables of the words as they are sung. The movement of the hands should indicate those notes that are to be prolonged or quickened. In the same way, raise or lower the hands to regulate the volume. Get into the proper swing and rhythm. Put some personality and pep into it. Put the entire body into song leading.
5. Insist on quality, not volume. Expect everyone to sing.
6. Use songs that fit the occasion. Start with lively songs and end the program with something inspirational.
7. Songs should be taught in the weekly den meeting, using songbooks only until the words are learned. Everybody should be ready for some real singing at the monthly pack meeting.

# WALK IN MY SHOES

## March 2004

### Cubmaster Corner - Pizzazz

#### TIPS Continued

8. If the first song doesn't measure up to expectations, "kid" the group along. Don't reprimand! For instance, try some competition. Put dens one and two against dens three and four... or boys against parents. Or moms against dads. Use only one short song to get everyone into the proper spirit.
9. In small groups, someone can often begin a song and everyone joins in naturally without formal leadership.

#### Cheers and Applause's

Applause stunts are a great way to recognize a person or den in a pack meeting for some accomplishment they have performed. Be sure before you start that everyone knows and understands the applause stunt and how to do it. Applause stunts serve more than one purpose -- they not only provide recognition but also help liven up a meeting. Applause stunts need to be fun. Strive for quality of performance in your stunts. Here's a fun one for you. Gather up all the cheers and applause's you can find, print them on card stock, cut each one out of the card stock page, and drop the whole bunch into a Cheer detergent box ~ empty of course. This is your "Cheer Box" for your Pack meetings. After skits or songs at the Pack Meetings, have a Scout come up, take a Cheer out of the Cheers Box, and lead it.

#### Den Yells

##### WHY DEN YELLS

1. Gives every boy a chance to participate at the Pack Meetings
2. Builds Den spirit and morale.
3. Gives the boys a chance to let off steam in an organized fashion.
4. If Den yells are worked out by the Dens, affords a chance for cooperative effort.

#### Run Ons

Run-ons are a terrific way to add some pizzazz to a Pack meeting. For best results, arrange them ahead of time, without the Cubmaster, or whoever is running the Pack meeting, knowing about it. That way they look more spontaneous, and the Cubmaster can easily become part of the joke.

Here are a few example:

A frantic figure runs on-stage.

- a. They're after me! They're after me!
- b. Who's after you?
- a. The squirrels - they think I'm nuts!

A dejected figure approaches his friend.

- a. It just doesn't work! It just doesn't work!
- b. What doesn't work?
- a. A dead horse!



# CUBSERVATION

## April 2004

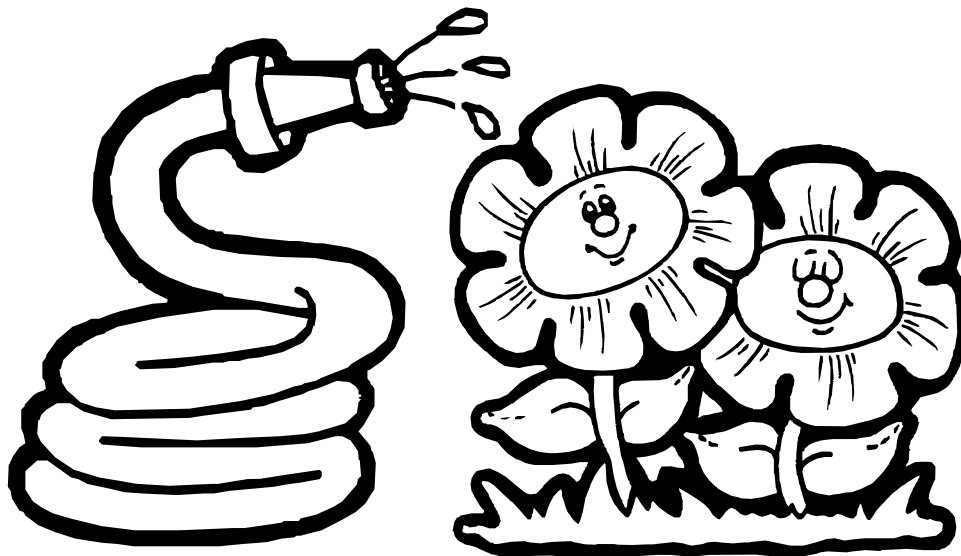

**This month our boys will learn about the importance of conservation and ecology. Have a conservationist or park ranger come to your den or pack meeting to talk about the dangers and effects of pollution and littering. Take your den to visit a local government conservation or reclamation project. Your den can plan its own conservation project and work on the World Conservation Award. Don't forget collecting and recycling old toys and clothes for those who are less fortunate. Your den may want to collect aluminum cans to sell and donate the proceeds to be used on a conservation project.**

Cub Scout Theme .....	03
Webelos – Sportsman .....	20
Webelos - Family Member.....	23
Tigers - Our Colorful World/Conservation.....	27
Cubmaster Corner - Reach out to the Community .....	30

### **We Are Not Experts**

We are not experts. We're your next door neighbors. We're not perfect, we are just parents like you. We don't have anymore spare time or energy than you do, we all work full time and juggle our families and our schedules and try to keep it all

# CUBSERVATION

## April 2004

together as best we can. The only difference between us is that we believe in what Boy Scouting has to offer. So much so, that we contribute our time, our miles and our talents to help our sons and your sons grow in Scouting.

We complete authorization forms, budgets and registrations and fill our homes with boxes of paperwork that you will never see. We are required to take training the first year, as well as attend Roundtable meetings every month, so that we can meet our greatest challenge providing a variety of programs which meet the needs and interests of very individual boys. We try to involve parents who want us to understand that they don't have the time to drive on outings or help at meetings. We rejoice at the generosity of others. Sometimes we find ourselves going in too many directions. We run out of steam. We have memory lapses. Communication lines break down. Time slips by. But that doesn't mean we don't care.

So many evenings we spend on the phone, seeking advice and support from other leaders when disappointments or problems occur. "How do I keep my boy's attention?" "What are your ideas for the ceremony?" "How do you work with boys in three different grades?" Our dining tables are covered with bits of rope, menus, tour permits and merit badge cards for each and every boy in the troop. A couple of them won't show up and don't think to call and let us know. Sometimes we feel unappreciated. Yet, these boys can fill us with pride at their determination and accomplishments. Their smiles light up a room; and when they say "Thank You" it makes it all worth it. We help these boys build relationships. Some struggle more than others.

Trustworthy, Loyal, Helpful, Friendly - is encouraged by the Scout Oath and Law. And sometimes we too must learn these lessons over and over again with the boys. But we are willing to keep learning.

Please be patient if we appear distracted or frustrated or overwhelmed at times. Forgive us if we are not the kind of Boy Scout Leader you would be if you had the time.

Instead, provide us with encouragement or offer your help. Keep us in your thoughts and prayers. We are, after all, only mentors, role models, leaders. Volunteers who have taken an oath to give these boys, your boys, the most precious gift we have to offer -- the gift of time.

Circle Ten Council, Author  
Unknown



# CUBSERVATION

## April 2004

### Gathering Activities

#### THE LITTERBUG

Divide group into each of the characters. As the key word is said each group makes the corresponding sounds.

*PAPER Crackle-Crackle, TRASH Dump-Dump, CANS Clatter-Clatter, LITTERBUG Toss and Throw*

NARRATOR: God put bugs in this world for many reasons. He made them to live in every kind of season. But the pesky LITTERBUG with his PAPER and CAN, was made through neglected TRASH by the foolish person. To keep America beautiful, get rid of the LITTERBUG, so beach goers can again lounge on a clean sandy rug. Because of this pest, we must woller around, In PAPER and CANS and TRASH all over the ground. Just who are these LITTERBUGS who mess up our land? Do you ever really see them toss that PAPER and CAN? Quite often the LITTERBUG is a sneaky guy, and at dumping his TRASH he's oh so sly. So most of the time it just appears everywhere, As if it had dropped right out of thin air. Could it be we are so used to throwing things here and there, that we dump that PAPER and CAN without being aware? Without even thinking when we toss TRASH and waste, we could be an unconscious LITTERBUG in all our haste. So when you unwrap that gum or small piece of candy, don't throw the PAPER on the ground just 'cause it's handy. Next time stop and think when a pop CAN you toss, cause if you're a LITTERBUG, it's also your loss. So if every single person would take note of his habit, that pesky LITTERBUG we could certainly nab it. Then that terrible bug we would surely stamp out, with no more PAPER or CANS or TRASH about. To keep America beautiful, we must all do our part, by taking care of our TRASH properly from the very start.

#### SOMETHING NOT TO BE

Fill in the missing letters in the spaces below with the letters listed below. They spell something no one wants to be. What is it?

B E G I L R T T U

BOTT\_\_ES  
T\_\_NS

S\_\_RING  
S\_\_ICKS  
PA P \_\_R  
T\_\_ASH  
RUB \_\_ISH  
J\_\_NK  
RA \_\_S

Answer: Litterbug

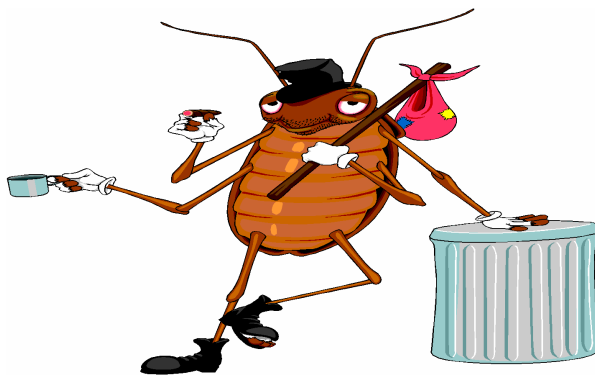

#### TREE LORE

Twenty leaves of local trees are placed before each den. The den has five minutes in which to write down the names of the trees. The den with the most correct answers wins.

# CUBSERVATION

## April 2004

### Openings

#### CONSERVE

Cub Scouts hold cutouts of cars made from poster board, with letters printed on back of each one to spell out the word: CONSERVE.

C - Cars and buses and such were invented by men.

O - Oil fields were discovered also by them.

N - Nobody really worried about the amount of fuel this would take.

S - So on no transportation did they put the brake.

E - Eventually the amount of fuel used grew astonishingly.

R - Raising on everyone's mind a great big doubt.

V - Very soon the world's traffic was put to the test.

E - Everybody to conserve fuel must now do their best!



#### ALLEGIANCE TO THE OUTDOORS

*SETTING: After presenting flags and Pledge of Allegiance, Den lines up across front of room.*

**NARRATIVE:** We are coming up on the time of the year when we start using the outdoors more and more whether we are hiking the trails of America or just going to the park. Each of us as Cub Scouts owes an allegiance to the outdoors just as we do our flag. Each Cub Scout should know and understand the outdoor code.

Cub 1: As an American, I will do my best to be clean in my outdoor habits, I will keep my trash and garbage out of America's waters, fields, woods and roadways.

Cub 2: Be careful with fire: I will build my fire in a safe place and be sure it is out before I leave.

Cub 3: Be considerate of the outdoors: I will remember that the use of the outdoors is a privilege I can lose by abuse.

Cub 4: And be conservation minded: I will learn to practice good conservation of soil, waters, forests, minerals, grasslands, and wildlife and I will urge others to do the same.

#### CONSERVING OUR NATURAL RESOURCES

*Personnel: Seven Cubs*

*Props: Seven candles in a candleholder, (a half log with 7 holes drilled in it would fit the theme) a lighter or matches and a candle for the Cubs to use to light the candles in the candleholder.*

*Scene: The CM or DL lights the "lighter candle". The Cubs each light a candle in the holder and read their part.*

CUB #1: We have been observing and studying Nature's treasures.

CUB #2: We will help to maintain nature's balance.

CUB #3: We will help and learn from nature's animals.

CUB #4: We will help and learn from nature's resources.

CUB #5: We will protect them from harm.

CUB #6: We will follow the conservation pledge.

CUB #7: Will you all please rise and join me in the conservation pledge.

"I give my pledge as an American, to save and faithfully defend from waste, the natural resources of my country, its soil and minerals, its forests, water, and wildlife."

Thank you. Please be seated.

# CUBSERVATION

## April 2004

### Den Activities

#### Things to discuss when it comes to saving resources...

##### Recycling

When an object can be shredded, melted or otherwise processed and then turned into new raw material -- for instance, aluminum cans can be melted down to make more cans, glass can make more glass, cardboard and paper make more cardboard and paper, plastic bags and containers can be turned into other plastic products. This takes some energy (very little for aluminum), but it is a good choice.

##### Reusing

When you find a use for an existing item - like decorating a bag and using it as a gift bag instead of buying wrapping paper; putting leftovers into a clean container from some other food; turning a used box into storage; decorating a can to hold pencils; saving packing peanuts and boxes and using them the next time you need to ship something or give a gift.

It is important to 'reuse' items wisely -- reusing packing peanuts to pack an item is by far the best way to use them. Recycling them, if it is available, would be the next best thing. Giving things in good condition that you no longer need to charity is another good way to reuse things like outgrown clothing or toys. Reusing is often the best way to save resources. This is something to consider year-round, not just around the winter holidays.

##### Shop Wisely

Can the container be easily recycled or reused? Will a larger container reduce the amount of packaging and perhaps cost less per serving? Is everything that can be recycled being recycled? Save resources (and money) by asking yourself if the item is something you really need, and if it is well suited for the task, and if it will last. Not only can this save you money, it can save you space and work, too. Five toys that are loved and played with are more fun than 10 toys that are broken or are boring to play with. And it's quicker to pick up 5 toys and put them away than to pick up 10.

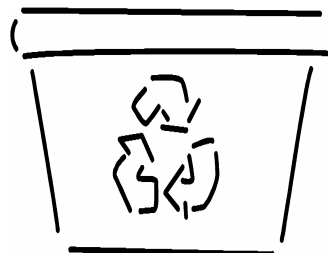

#### After discussing ways to recycle do the following activities:

1. Divide den into two teams. Open up a mystery trash bag at each table and identify which things can be recycled. Lift up the bag again and feel how much lighter it is when people take things out of the trash, which can be recycled

2. This activity was adapted from a lesson written by: Phyllis Youngberg, a teacher at Burnt Mills Elementary School.

NOTE: If there is a tree on or near the school grounds, take the den outside for this activity. If there are no trees, have the den look at pictures of trees.

Give the boys a pencil and paper. Tell them they are going to examine a specific tree. Use the following procedure:

- A. Ask them to use their senses to make observations about the tree. (Provide them time to do this silently, then discuss in the den)
- B. Have them touch and smell the tree.
- C. Ask them to close their eyes and listen for sounds associated with the tree.
- D. Next, have them look for signs of who or what uses the tree, then discuss their observations.
- E. Ask: "What could hurt the tree? How? Why?"
- F. Pose the following "What if" questions for them to consider:

# CUBSERVATION

## April 2004

### Den Activities

- a. What if this tree (or all the trees in our community) were gone? What would be good/bad/interesting about that?
  - b. What if the birds that use this tree went away? What will be good/bad/interesting about that?
  - c. What if lots of trees were planted on the school grounds? What would be good/bad/interesting about that?
- G. Ask: "Whose job is it to care for the tree? Why?"

3. If the weather is pleasant, ask the boys to go outside to sit and observe the area around them. They are to use their senses to observe other things in nature (sky, ground, plants, birds, etc.) Have them take a pencil and/ or crayons and paper and:

- A. Draw a picture of themselves outside.
- B. Draw their observations.
- C. Draw or write about their feelings about nature. (Provide ample time for this.)

When the boys return inside, provide time, if needed, to complete their work. Then have them share their work. Use the opportunity to discuss the importance of taking care of all things that are provided by the Earth.

4. Different types of walks you can take with the boys.



**RAINBOW WALK** — look for items of different colors, try a color per block or every so often, or just plain color identification.

**HAWKEYE WALK** — a list of items to spot or pictures of items to look for.

**SUNSHINE AND SHADOW WALK** — play with the shadows, measure some, make creatures, play shadow tag.

**PHOTO WALK** — take pictures before and have the boys look for certain items. Try weekly pictures to sequence spring development.

**BINOCULAR WALK** — make binoculars for toilet tissue rolls and use them on the walk to focus on items. It makes for a new look at the same old scenery.

**ALIEN WALK** — take your walk on this planet earth as if you were from another planet. Try to identify the things you see, not knowing their real name or purpose.

**BINGO CARD WALK** — on a bingo type card, with pictures or drawings of items, go for a walk to identify the items on the card.

**SIGNS OF POLLUTION WALK** — clean up the environment as you go using plastic gloves to protect hands.

**ALPHABET WALK** — make a list of things with letters of the alphabet and have the boys identify them.



# CUBSERVATION

## April 2004

### Crafts

#### COFFEE GROUND 'FOSSILS'

##### What You Need

- 1 cup of used coffee grounds
- 1/2 cup of cold coffee
- 1 cup of flour
- 1/2 cup of salt
- Wax paper
- Mixing bowl
- Some small objects to make impressions in the dough
- Empty can or a butter knife
- Toothpicks, optional
- String to hang your fossil, optional

##### How To Make It

1. Stir the together the coffee grounds, cold coffee, flour, and salt until well mixed.
2. Knead the dough together and then flatten it out onto the waxed paper.
3. Use the can to cut out circles of the dough or use the dull knife to cut slabs large enough to fit your "fossil" objects.
4. Press your objects firmly into the dough. When you take the object out, you have your "fossil". If you want to hang the fossil, poke holes into the edge to hold the string.
5. Let the fossil dry overnight and then hang it if you wish.

##### Tips

Bake them for a short period to get the "dough" to harden.

#### BIRD FEEDER

by Lynda Musante

##### You will need:

- 3" Wooden disk
- 3 Plastic coated wire hangers
- 16 Gauge wire
- Plastic container or used margarine tub
- Nail
- Craft Snips
- Sand paper
- White glue
- Bird seed
- Pine cone
- Peanut butter



# CUBSERVATION

## April 2004

### Crafts

#### BIRD FEEDER Continued



Fold bottom of hanger up over hook to make wings.



Shape hook and hanger to make arms and body.



Attach food dish to bottom of hangers with wire.

#### Instructions:

1. Sand disk smooth. Spread glue on disk to seal wood. Allow to dry.
2. To make wings, squeeze the hanger hook of one hanger closed. Pull the center of the hanger up to the hook of the hanger and loop it into the twisted section to secure. Bend hook over the loop.
3. To assemble the body, straighten the hooks on two hangers and bend them at a right angle. They will become the arms. Insert one hanger crossways into the second hanger. Bend both arms forward. Cut a 12" length of wire. Hold wings in position and wrap wire around all three hanger's twisted sections to secure.
4. Pull down the wide section of the two body hangers and flatten center area. Use nail to poke two holes 1" apart at the center point on each side of the plastic container bottom. Cut four 3" lengths of wire and bend each piece into a "U" shape. Insert a wire "U" through one set of holes and position container over bent hanger. Twist wire to secure it to the hanger. Repeat with three other sides.
5. Fill container with birdseed. Spread a pinecone with peanut butter then squeeze arms together to hold it. Your bird feeder can stand in the garden or hang.
6. Glue disk to top for face.

# CUBSERVATION

## April 2004

### Songs

#### **Planet Earth's Our Only Home**

*(to the tune of Old McDonald)*

Planet Earth's our only home,  
It is in our hands.  
We must learn to keep it safe,  
The seas, the skies, the lands.

#### **Chorus**

With recycling,  
And conserving,  
I know I can, I know you can,  
Yes it true, I know we can!  
Planet Earth's our only home,  
It is in our hands.

It's home to birds up in the sky,  
Fishes in the sea.  
It's home to creatures on the ground,  
It's home to you and me.  
*(Repeat Chorus)*

Turn off water, dim the lights,  
Kids can do their part.  
Making changes to conserve,  
Is just being smart.  
*(Repeat Chorus)*

<http://www.buschgardens.org/AnimalsAbound/musicalmemories.html>



#### **Picking Up the trash**

*(to the tune of "I'm Picking Up a Baby Bumble Bee")*



I'm picking up some trash from the big blue sea.  
Keeping the ocean clean for you and me.  
I'm picking up some trash from the big blue sea.  
Why don't you come and join me!  
My friends and I are cleaning up the sea,  
For whales and dolphins swimming happily.  
My friends and I are cleaning up the sea.  
Look how pretty it can be.  
We're keeping all the oceans nice and clean.  
Have some fund and join our clean-up team.  
We're keeping all the oceans nice and clean.  
Come and join our team!

# CUBSERVATION

## April 2004

### More Songs

#### What Shall We Do With a Litter Dropper?

*(Tune: What Do We Do With a Drunken Sailor)*

What shall we do with a litter dropper

What shall we do with a litter dropper

What shall we do with a litter dropper

Early in the morning?

Put them in the bin, let the garbage truck take them *(say 3 times)*

Early in the morning.

What shall we do with the bottle smashers

What shall we do with the bottle smashers

What shall we do with the bottle smashers

Early in the morning?

Let the recycling truck take them *(say 3 times)*

Early in the morning.

What shall we do with the tin can tossers

What shall we do with the tin can tossers

What shall we do with the tin can tossers

Early in the morning?

Put them in the bin, let the garbage truck take them *(say 3 times)*

Early in the morning.

What shall we do if they take no notice

What shall we do if they take no notice

What shall we do if they take no notice

Early in the morning?

Pitch right in and stop all littering, etc. *(say 3 times)*

Early in the morning.

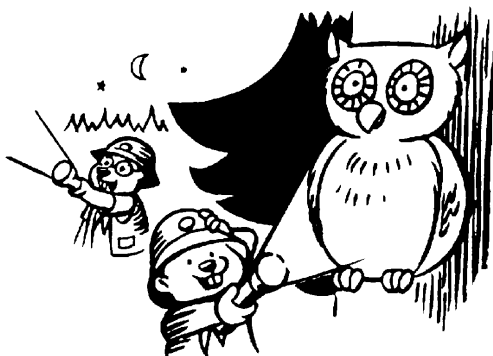

#### Recycle Song

*By Sue Parr-Jourdain*

*Tune of "Row, Row, Row Your Boat."*

Pick, pick, pick it up

Put it in a can,

Please don't litter, it makes us bitter

Don't dirty up our land.

Re, re, recycle

Paper, plastic and glass

We're the solution, to stop pollution

It will be a blast!

# CUBSERVATION

## April 2004

### Even More Songs

#### **Pollution Song**

*(Tune: My Bonnie Lies Over the Ocean)*

The litter blows over the highway,  
The litter blows over the park,  
Unless we do something about it,  
The world will be litterly dark.  
Pick up, pick up,  
Oh, pick up the litter you see, you see.  
Pick up, pick up,  
Oh, pick up the litter you see.

The cars that drive over the highway,  
Are spewing exhaust in the air,  
We're leading our world in extinction,  
And yet just don't seem to care.  
Bring back, bring back,  
Bring back a clean world to me, to me.  
Bring back, bring back,  
Please bring back a clean world to me.

God gave us clean air for our breathing  
But we just don't keep it that way,  
Instead we pollute it from smokestacks  
And breathe in the garbage each day.  
Bring back, bring back,  
Bring back a clean world to me, to me.  
Bring back, bring back,  
Please bring back a clean world to me.



#### **Picking Up Litter**

*(Tune: I've been working on the Railroad)*

I've been pickin' up the litter,  
All the livelong day.  
I've been pickin' up the litter,  
Just to have a place to play.  
Can't you see the litter basket,  
Sitting on the sidewalk there?  
Every little bit will help us,  
If you just show you care.  
Won't you pick it up?  
Won't you pick it up?  
Won't you pick it up today, today?  
Help us clean it up,  
Help us clean it up,  
Help clean up the U S A

# CUBSERVATION

## April 2004

### Skits

#### **EARTH DAY**

Adapted from a poem by Hillol Ray.

Divide into parts. Have the boys hang a poster around their neck with different recycle items. Bottles, can, newspaper, etc.

Fresh air and clean water nourish our souls,  
Without them, we suffer, and pay a heavy toll!

Banning pesticides and lead in gasoline -  
Made the giant move to make the nature clean!

Recycling became a daily household chore -  
To reduce costs and protect the seashore!

Reduction of emissions created the flow -  
Of cleaner air, and polluters took a blow!

The situation has changed over twenty-five years,  
And laws are in place to remove our fears!

Now, always think "Earth Is In Your Hands",  
Here at home or in foreign lands!  
So let us follow these few simple roles,

Conserve the water as much as you can,  
While you are bathing or washing the van!

Recycle and prevent pollution at the source,  
Plant the trees in open private space,  
To create the shade and cool your face!

Well, now you know what you have to do -  
And celebrate "Earth Day" without further ado!

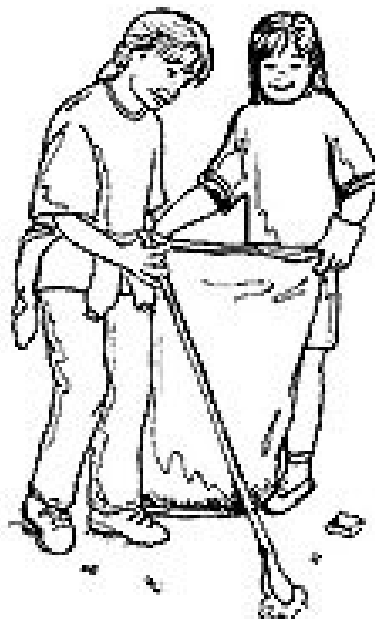

#### **BACK TO NATURE**

Decorate 8 large shopping bags; label 4 "Dirty Bugs", and the other 4 are "Tidy Bugs." Each boy carries one with his lines written on it near the top. If desired, they can also decorate a smaller paper sack like a bug to wear over their head.

Cub 1: My name is LitterBug Lou. And oh, what us litterbugs do!

Cub 2: We clutter the country with papers and trash. At making a mess, we're really a smash!

Cub 3: The roadsides and parks are scenes of our folly. We really enjoy it and think it quite jolly.

Cub 4: To leave behind garbage, bottles and paper, as little memories of our daily labor.

Cub 5: I'm Tidy Bug Ted of the Tidy Bug clan. We work to keep things spick and span!

Cub 6: We pick up the litter wherever we are and always carry litter bags in our car.

Cub 7: We'll wipe out Lou and all of his band and make America a beautiful land.

Cub 8: Free of litter, trash and clutter. Won't you help us, dear Father and Mother?

# CUBSERVATION

## April 2004

### Games

#### SUN AND SEEDS

Boys form a circle and kneel with hands over their faces as if they are sleeping seeds. One Boy is named the sun. He runs around the circle and touches a seed. The seed jumps up and chases the sun around the circle. The sun must make it to the seed's vacant place without being tagged. The seed then becomes the sun and tags someone else. If the sun is tagged by the seed before reaching the seed's place, he is the sun again.

#### QUIET RECYCLE ACTIVITY

Unscramble our recycling world. Have the boys unscramble the word in the highlighted box below to spell how our state will look if we all recycle our waste.

Litter    Reduce    Cardboard    Compost    Reuse    Landfill    Recycle    Ecology

Resources    Glass    Aluminum    Newspaper

1. ecreyle	-----	-----	-----	-----	-----	-----	-----
2. tltrei	-----	-----	-----	-----	-----	-----	-----
3. locyoge	-----	-----	-----	-----	-----	-----	-----
4. drecee	-----	-----	-----	-----	-----	-----	-----
5. erutosecs	-----	-----	-----	-----	-----	-----	-----
6. bocadrdra	-----	-----	-----	-----	-----	-----	-----
7. lsgsa	-----	-----	-----	-----	-----	-----	-----
8. pcmoots	-----	-----	-----	-----	-----	-----	-----
9. umualimn	-----	-----	-----	-----	-----	-----	-----
10. uesre	-----	-----	-----	-----	-----	-----	-----
11. apwreesnp	-----	-----	-----	-----	-----	-----	-----
12. fladlinl	-----	-----	-----	-----	-----	-----	-----

BONUS word \_\_\_\_\_

Bonus word answer: CLEAN



# CUBSERVATION

## April 2004

### Advancement Ceremonies

#### **POLLUTION SOLUTION**

This month our Cub Scouts have been learning about their environment and how to be part of the solution to pollution rather than contributors to the problem. They have learned to re-use, reduce, and recycle products in their home. They have participated in service projects to help fix existing problems in their neighborhoods and parks. Tonight we honor some of those service minded Scouts who have completed requirements for their rank advancements.

The Bobcat Trail is the beginning of the Cub Scout adventure. The boys attaining this rank have just begun to learn the meaning of service to others as they learned the Cub Scout Promise and Law of the Pack. (Call boys and parents forward.)

In attaining the rank of Wolf, boys learn about our "Living World" and how to protect it. They have made observations about how their neighborhoods get dirty, then gone into action to help be part of the solution to the problem. (Call boys and parents forward.)

The Big Bear Trail is full of choices, and some of those choices deal with "Taking Care of Your Planet" and "Sharing Your World With Wildlife." Boys attaining this rank have learned something of the interdependence of life on Planet Earth, that all living things need each other. (Call boys and parents forward.)

Learning the Outdoor Code is one of the requirements for attaining the Webelos Rank. In preparing for Boy Scouts, these boys will be spending more and more time outdoors, and their conduct toward the environment could impact generations to come. (Call boys and parents forward.)

The outdoor program is an important part of the Scouting movement. Be a leader in your school, your home, and your neighborhood to preserve this precious environment for our future.

#### **CUB SCOUT SEEDLING**

*STAGING: Cardboard trees and bushes in background.*

CUBMASTER: Do you see that tree in my backyard. My first den & I planted that tree as a seedling the first year my oldest joined Cub Scouts. Look at it now! We did it as a conservation project to show how we can help our environment.

ASST CM: Wow, it sure has grown!!

CUBMASTER: A young Bobcat starting his Cub Scouting adventure may be like a young seedling just starting to grow like that one used to be in my backyard. We have several Cub Scouts that have earned the Bobcat rank.

ASST CM: Will the following boys and their parents please join us in the backyard.  
(Reads names)

CUBMASTER: These Cubs, like a planted seedling, have just started. Parents, I give you the Bobcat Badge to present to your sons.





# CUBSERVATION

## April 2004

### Advancement Ceremonies

#### CUB SCOUT SEEDLING Continued

CUBMASTER: A young Wolf has gone beyond the bobcat, like the seedling becoming a tree.

His limbs extends high and becomes visible to the neighborhood reaching out to see and learn.

ASST CM: We have several Cub Scouts tonight that have earned the Wolf Badge, the second rank in Cub Scouting.

Will the following boys and their parents come into the backyard. (Read Wolf names)

CUBMASTER: A Wolf Cub has accomplished more than the Bobcat. His experiences, skills, and knowledge have begun to extend beyond his home and has become visible to others.

Parents, please present these Wolf Badges to your sons.

CUBMASTER: The Bear Scout, the third rank of Cub Scouting, has continued up the Scouting trail beyond the Wolf. He has become strong and straight as a young tree, not fully grown yet, but on his way. His search extends beyond his neighborhood into the town and country. His experiences could be fishing in a creek, a hike through town, or visit to local park or zoo. We have several Cub Scouts that have met the challenges of the Bear and will receive their awards tonight.

ASST CM: Will the following Cub Scouts and parents join us. (Read names)

CUBMASTER. The Bear Scout has matured and endured the challenges of the Cub Scout trail. His experiences and knowledge are nearly complete. His backyard is beyond his neighborhood. Parents please present these badges to your sons.

CUBMASTER: The Webelos Scout is coming to the end of the Cub Scout Trail. He is a fully grown tree in the Cub Scout forest. He stands straight and tall. His backyard extends up and down the highways. His fun may include Canoeing at a Cub Scout camp, hiking in the woods, and camping overnight. We have several Cub Scouts here tonight that have met the Webelos challenges.

ASST CM: Will the following boys and their parents join us in our backyard.

CUBMASTER: The Webelos Scouts have almost completed the Cub Scout trail. They are knowledgeable, skillful, and confident. His backyard is almost limitless. Parents please present these badges to your sons.



# CUBSERVATION

## April 2004

### Run On/ Applause

#### RUN ONS

Cub 1: What did the big chimney say to the little chimney?

Cub 2: I don't know.

Cub 1: You're too young to smoke!

Cub 1: Everyone knows we should conserve energy. Can you name one way to do that?

Cub 2: By staying in bed all day!

Cub 1: What is the first thing you should do with a barrel of crude oil?

Cub 2: Teach it some manners!

Cub 1: Do you know what will happen when man pollutes outer space?

Cub 2: No, what will happen?

Cub 1: The Milky Way will curdle.

Cub 1: (reading statistics) Do you know that every time I breathe, someone dies?

Cub 2: Have you tried mouthwash?

Cub 1: What is blue and gold and covered with dirt?

Cub 2: A Cub Scout who has gone back to nature.

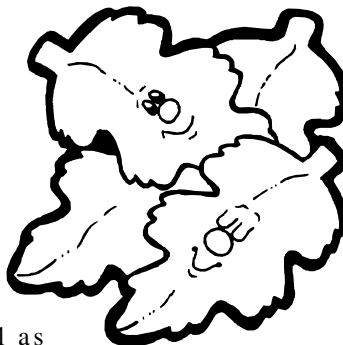

#### APPLAUSE

**Clean Air:** Take a big sniff of air, exhale and say "AHHHHHHHHHHHHHHH!"

**Noise Pollution:** Raise hands and have everyone yell as loudly as they can. Lower hands and volume of yells go down. When hands are on floor, everyone must be extremely quiet. Do several time – raise and lower volume. Then, with hands on floor ask the Pack to listen to absolute quiet.

**Reduce, Reuse, Recycle:** Divide the audience into three sections. Have the first section yell, "Reduce!", the second section yell, "Reuse!", and the third section yell, "Recycle!" Alternate pointing at each section, pointing faster and faster.

**Reverse Applause:** Move hands away from each other.

**Plant:** Crouch near floor, take deep breath, hands together, like saying prayer with eyes closed, slowly rise upward spreading fingers and as you are on tip-toes, look up (to sun,) open eyes and exhale "Ahhhh."

# CUBSERVATION

## April 2004

### Closings

#### **THIS APPLE IS THE WHOLE WORLD**

*\*This ceremony involves the use of a pocketknife, so an adult should handle this.*

*PROPS: Apple, Pocketknife, Table*

CUBMASTER: Earth Day comes in April and it reminds us to be careful with our home planet. There is also an old song about April showers bring May flowers. Together, these remind me of how precious and valuable water is, and how important it is to use it wisely. I

Imagine that this apple is the whole world. Three quarters of the world is covered with water, and only one quarter is covered by land. (Cut one-fourth section off of apple and place it down on the table.)

Out of the three quarters covered in water, only about three percent is fresh water and the rest is salt water, mostly in the oceans. (Cuts off thin sliver from apple, and places larger piece down on the table. Holds the thin sliver up for all to see).

Of this 3% slice, about two-thirds of that is generally not available. Most of that is frozen in the North Pole and South Pole, and other hard to reach places. (Cuts off two thirds of the thin sliver and puts larger piece down).

Only this thin sliver is left. All the fresh water that is available to life on the land's surface. This is all the fresh water we have. What would happen to us if we ruin this thin sliver by pollution? (Eats thin sliver in one bite).

We would be gone just like that. Be careful with the world. We need to save it for all these young people here tonight.

#### **WALK THROUGH THE WOODS**

The Cubmaster can simply read this or you can add music and trees in the background as props and have the boys in the dens walk out on stage as the words are being read.

When you walk through the woods, I want you to see,  
The floating gold of a bumblebee  
Rivers of sunlight, pools of shade  
Toadstools sleeping in a mossy jade.  
A cobweb net with a catch of dew.  
Treetop cones against an azure blue.  
Dancing flowers, bright green flies  
Birds to put rainbows in your eyes.

When you walk through the woods, I want you to hear,  
A million sounds in your little ear.  
The scratch and battle of wind tressed trees  
A rush as a timid chipmunk flees  
The cry of a hawk from the distant sky  
The burr of the leaves when a breeze rolls by  
Brooks that mumble, stones that ring  
And birds to teach your heart to sing.

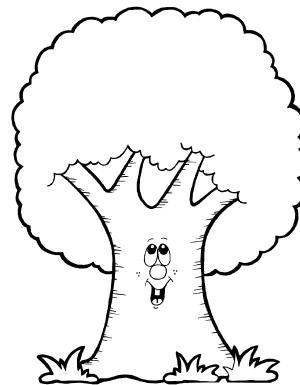

# CUBSERVATION

## April 2004

### Closings

#### WALK THROUGH THE WOODS Continued

When you walk through the woods, I want you to feel  
That not we nor man could make this real  
Could paint the throb of a butterfly's wing  
Could teach the woodthrush how to sing  
Could give the wonders of earth and sky  
There's something greater than you or I

When you walk through the woods and the birches nod  
Son, meet a friend of mine, named God.

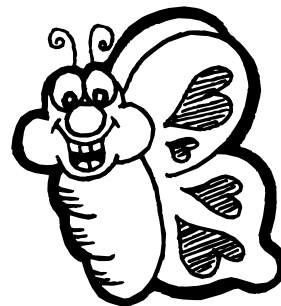

#### A NATURALIST IS ...

No matter where you live, there is a world of undiscovered secrets of nature still waiting to be explored.

A naturalist is a student of natural history which includes the many things found in nature, such as plants and animals. This month, our dens have (briefly review some of the den activities an the theme)... There are many more interesting activities to help you Cub Scouts learn more about the world of nature and to develop an appreciation of it.

A naturalist stands like Columbus on the prow of his ship with a vast continent before him... except that the naturalist's world can be at his very feet... a world to be investigated and discovered. It is as near as your own backyard; a nearby park, the woods and fields or even a country road. These places are inhabited by many kinds of insects, birds, plants, animals, trees and other forms of life. Continue exploring the world of nature and you will find many wonderful things that God has given us to enjoy.

#### NATURE CLOSING

Wood and water, wind and tree,  
Wisdom, strength, and courtesy,  
Scouting favor go with thee.

#### A TREE IS A GOOD SCOUT

*Personnel: 6 Cubs and a narrator*

*Equipment: Each Cub hold a picture or drawing of a tree with his section of text on the back.*

Cub 1: Did you ever pause to think about how helpful a tree is?

Cub 2: It provides a nesting place for birds, shade from the sun, and protection from the rain.

Cub 3: It discards it's dead branches, thus providing wood for building fires and for cooking food.

Cub 4: A tree adds beauty to the countryside and to camping areas.

Cub 5: We must admit that a tree gives a lot more than it receives.

Cub 6: We can learn a lesson from the tree , by doing our best to always be helpful to others and by putting our fellow Scouts first and ourselves second.

Narrator: Remember the lesson we learn from the tree - To give to others more than we receive.

# CUBSERVATION

## April 2004

### After the Meeting

#### DIRT PIE

1.25# package Oreo's  
1/2 stick margarine  
8 oz cream cheese  
1 cup powdered sugar  
3.5 cups milk  
2 sm. boxes instant vanilla pudding

12 oz Cool Whip

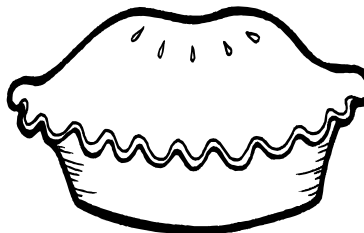

#### DIRECTIONS

Crush Oreo's until fine. Cream margarine, cream cheese and powdered sugar together. Mix milk and pudding and combine with margarine mixture. Mix well, then add Cool Whip. Thoroughly clean out a new plastic flowerpot with soap and hot water. Alternate layers of Oreo crumbs and pudding mixture in the containers with Oreo's on both the bottom and top layers. This cake looks especially good if you add gummy worms for special effect.

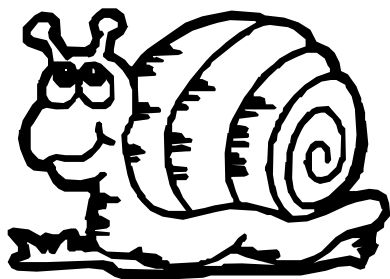

#### WORMS ON A BUN

Hot dogs,  
Hamburger rolls  
Ketchup

#### DIRECTIONS:

Cut the hot dogs into thin slices and score the edges (about three cuts per slice). Boil or microwave until the slices curl like wiggly worms. Serve three or four worms to a bun and, for an extra-icky touch, add a few squiggles of colored ketchup.

#### SEWER SODA

1 qt Chocolate chocolate chip Ice Cream

3/4 c Chocolate syrup  
1 liter Club soda  
Large Spoon  
4 Tall glasses & spoons  
Straws

#### DIRECTIONS

Let ice cream sit at room temperature until it is easy to scoop. Spoon ice cream into glasses until it is about halfway full. Pour or squeeze about 3 tablespoons chocolate syrup into each glass. Slowly fill almost to the top with club soda and stir well with a spoon. Serve with a straw and tall spoon for excavating those luscious brown lumps. Serves 4 sewage slurpers.

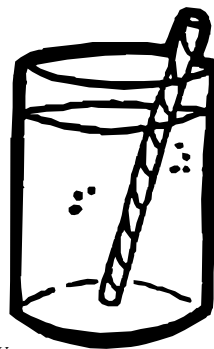

NOTE: Gross serving suggestion! To make this slop especially disgusting, plopp an unwrapped tootsie roll into each glass, the boys just love it!

# CUBSERVATION

## April 2004

### Sportsman

Sports are high on the list of favorites of Webelos age boys. You can be certain of instant interest by most members of your den. Chances are that they spend much of their leisure time in organized sports and loosely organized neighborhood games. Some of them probably know enough already about rules, scoring, and techniques for several sports so that they could pass the badge requirements easily.



But that's not really enough. One of the prime purposes of Cub Scouting is encouraging good sportsmanship and pride in growing strong in mind and body. If your boys learn all the skills and rules involved in every sport this month, and don't get an inkling of what good sportsmanship means...then the den, and you, have wasted your time.

Agree on the importance of learning sportsmanship. What does that mean in practice? It means that the least skilled gets just as much instruction and encouragement as the best athlete. It means that the better athletes learn not just to tolerate the awkward boy, but learn to help him. It means that all boys can win and loss with grace and good sportsmanship.

Your own example will help to achieve these goals. Put stress on the fun of the game, not on the winning. When you have den competitions, make up the teams so that the strength is about even. If you let boys choose teammates, there is a good chance that most of the best players will wind up on the same team. Encourage the less skillful players. Discourage others from belittling them. Sports in a Webelos den should be fun for all the boys.

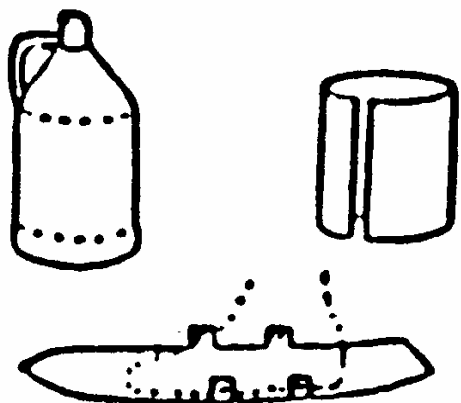

#### SKI-SKATE TAG

For a pair of shorty skis, remove top and bottom of two gallon plastic bottles. Cut down seams and flatten into strips, curved at the ends. Stand on center of the plastic and mark width of shoe at the widest point. Mark small tabs on each side of foot and a second pair of tabs near ankles. Cut plastic to the width of foot with tabs attached. Trim skis to a point at the front. To fasten skis to shoes, punch holes in tabs. Bend tabs up and lace with ribbon or cord, lacing over tops of shoes and around ankles.

# CUBSERVATION

## April 2004

### Sportsman

#### Den Meeting Ideas

- ◆ Demonstrate the signals of baseball and have the boys do them
- ◆ Hold parent/son bowling contest
- ◆ Discuss the rules and regulations of various sports
- ◆ Attend a high school, college or professional sporting event
- ◆ Have a Lad/Dad Sunday and all watch a pro game on TV (combine with a cookout)
- ◆ Have a fishing derby
- ◆ Play miniature golf
- ◆ Have a referee talk to the boys about the rules of his sport
- ◆ Walk a golf course and observe the play (get permission first!)
- ◆ Have archery practice using targets against bales of hay
- ◆ Visit a tennis court or racquet club
- ◆ Have a high school coach come and talk about what it takes to become a good athlete

#### WHAT SPORT ARE WE???

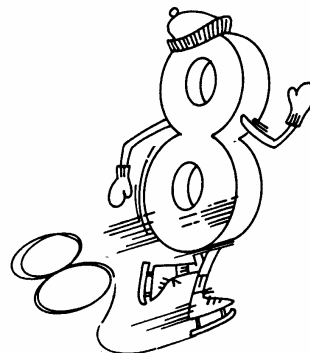
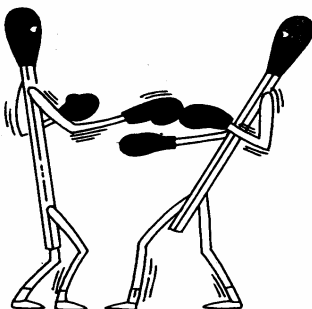
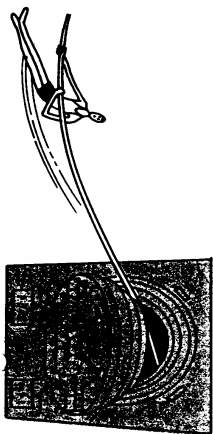

ANSWER : Pole vaulting, Boxing match, figure 8 skating

#### SOCCER BALL NECKERCHIEF SLIDE

*Materials:*

*Ping Pong ball*

*Plaster*

*Pop top ring or small 1/2" pvc pipe ring*

*Black acrylic paint*

#### DIRECTIONS:

Cut a ping-pong ball in half. Fill the half of ball with plaster and insert pop top or PVC ring for slide.

Decorate with black paint. The same idea can be used to make a Basketball, etc.

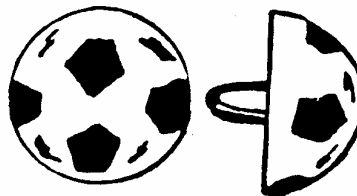

# CUBSERVATION

April 2004

## Sportsman

### BASEBALL GAME

*Need:*

*Large sheet of cardboard (can be any size so long as it is square)*

*Marking pens*

*Paper brad*

*Let each of the boys make their own to take home.*

Cut a large square from the cardboard. Using marking pens draw a baseball diamond on it like the one shown. Mark home plate and three bases. Outside of the baselines write as shown: Home Run, Strike, Single, Out, Double, Ball, and Triple.

Draw pitcher's mound in the center. Cut a bat shape spinner from cardboard. Punch small hole in bat and center of pitcher's mound. Attach bat with paper brad to pitcher's mound. Be sure that the hole is not too large or too small, needs to be large enough for the bat to spin freely.

Follow regular baseball rules when playing. Keep score. Each player keeps his turn until he has three outs.

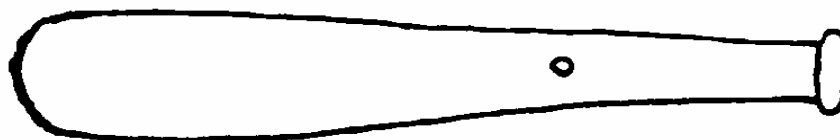
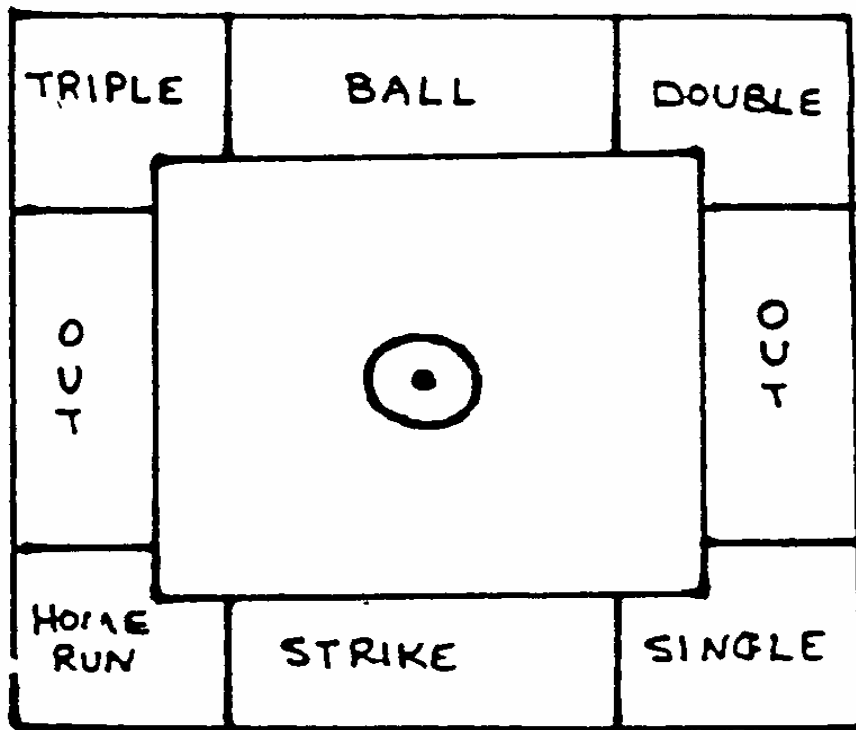



# CUBSERVATION

## April 2004

### Family Member

#### WATER YOU USE YOURSELF

There is little danger of North America running out of water. But there is a danger that we will run short of pure water. You can help prevent this by using only as much water as you need. If you study how you use water now, you will be able to find ways to use less. Study the two charts below. Then keep this sheet with you for a DAY. Mark it each time you use water. You can use the back of this paper to do your figuring.

Remember that this is an estimate, not an exact measure of how much water you use.

Therefore, you can use the average amount given in the second column when you do your figuring. For example, if you get six drinks of water a day, you would estimate  $6 \times \frac{1}{4} = 1\frac{1}{2}$  gallons. (Note: The averages assume you let the water run to get hot or cold. You wouldn't for example, drink  $\frac{1}{4}$  gallon of water each time you get a drink, but that much would run from the faucet if you let it run to get cold). Enlarge chart to desired size.

DAILY WATER USE			
How you use it	Average amount	Put "X" for each use	Total
Taking a bath	30 gallons		
Taking a shower	20 gallons		
Flushing a toilet	3 gallons		
Washing hands or face	2 gallons		
Getting a drink	$\frac{1}{4}$ gallon		
Brushing teeth	$\frac{1}{4}$ gallon		
Other	you estimate		

#### YOUR SHARE OF THE FAMILY'S WATER

FAMILY'S WATER			
How you use it	Average amount	Put "X" for each	Total
Washing dishes for one meal	8 gallons		
Cooking a meal	5 gallons		
Using automatic clothes washer	32 gallons		
Other	You estimate		

Some water is used for the good of everyone in your family, such as water for cooking and cleaning. This chart can help you estimate your share of that water. Suppose, for example, that there are five people in your family. If you estimate that water for meals, cleaning and other family uses equals 100 gallons, your share is 100 divided by 5, or equals 20 gallons.

Enlarge chart to desired size.

# CUBSERVATION

## April 2004

### Family Member

A definition of a family is “all the people living in the same house.” Families have many and varied faces. Some families are the traditional mother, father, and children, while others are one-parent families. Still other families consist of grandparents raising grandchildren. Even if a guardian is in charge of rearing a child, we hope that love and understanding is part of every family structure.

The family member activity badge helps each boy understand his family and his part in that family. This badge is geared to open each boy’s awareness of how the family works and what makes the family work well. Chores, laundry, grocery shopping, and house cleaning are all elements included in the family unit. Remember to stress that each boy is important to his own family and that his family is important to him.

#### *PURPOSE*

Because of the importance of the family involvement in this activity badge. It’s a good idea to hold a parent’s meeting to explain the requirements and give some suggestion on how they can work with their son on this badge.

Remember that the parent should initial the completed requirements, but a review of the activities with the individual boys at a later meeting by the Webelos leader will ensure that all the activities were properly completed.

Another good approach is to let the boy’s plan a “Family Day: for a Saturday or Sunday afternoon of fun for their parents and siblings. The boy’s creativity and resourcefulness will amaze you and entertain everyone who attends.

Make sure the presentation of this badge at a pack meeting includes the family.

#### **SUGGESTED DEN ACTIVITIES**

- ◆ Invite a fireman, policeman or security guard to a den meeting to talk about home safety. Perhaps he can also provide you with a home inspection sheet.
- ◆ Invite a home economics teacher or dietician to talk to your den. Perhaps your den could also plan a weeks worth of meals for a family and visit a retail food establishment and price the food required to sustain this family and see how it relates to the budget of a family budget.
- ◆ Tour a waste disposal facility; have an employee give a talk.
- ◆ Invite an energy conservation engineer to give a talk on energy.
- ◆ Make a list of fun activities that involve little cost; do them over several meetings.
- ◆ Invite someone from a professional home cleaning service to give a talk on how to properly clean things.
- ◆ Tour a fast food restaurant or small café.
- ◆ Have someone from OSHA or a plant safety committee give a talk after touring a manufacturing facility.
- ◆ Have a family relation’s teacher visit and talk.

# CUBSERVATION

## April 2004

### Family Member

#### SUGGESTED DEN ACTIVITIES *Continues*

- ◆ Switch chores with another family member for a month.
- ◆ Keep a personal budget for a month.
- ◆ Tour an energy conserving home that is built in the area.
- ◆ Visit with a local financial institution to find out how the monetary system works and how saving money as a family unit can be beneficial in the long run.
- ◆ Contact local public utility companies, or the environmental control agency to find out how our natural resources can be saved and what we as individuals within the family unit can do to conserve energy.

#### NEWSPAPER HAMMOCK

Instead of recycling old newspapers, why not turn them into a hammock? Here's how.

*Materials:*

*LOTS of newspaper*

*Tape*

*An old bed sheet*

*Rope or strong clothesline cord*

*Scissors*

#### **DIRECTIONS:**

Make a stack of 30 sheets of newspaper. Roll up the stack the long way to form a tight, narrow tube. Tape the tube closed.

Repeat step 1 until you have about 20 tubes.

Cut three lengths of rope or clothesline, each at least 12 feet long. Lay the ropes parallel to one another.

Now tie each tube, one by one, to the ropes. Tie over and under knots, leaving 2" to 3" between each tube (A). Remember to leave at least 3 feet at the end of each rope so you can hang up the hammock.

When the hammock is long enough for you to lie in, tie the ropes together at each end (B). Hang your hammock between two trees in your back yard, or ask your mom or dad to help you hang it from your patio roof. Throw an old bed sheet over the hammock so you won't get newsprint on your clothes.

**ONE STEP FURTHER:** Try making a hammock out of brown shopping bags. Cut the bottom off each, then cut along a side seam and spread open the bag. Stack several bags, then roll them up.

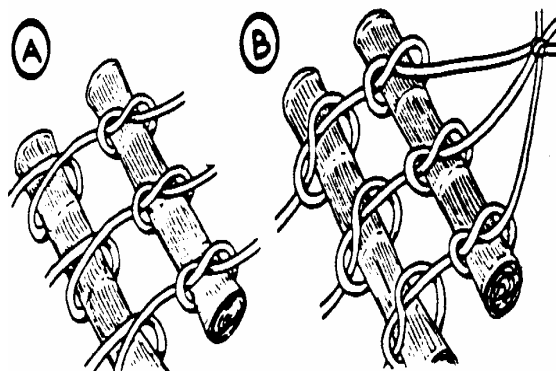

# CUBSERVATION

April 2004

## Family Member

Stores, factories, cars, offices, schools, trucks and planes use most of the energy in our country. But a lot of energy is also used in our homes. And that is the one place that all of us can help to save energy. Here is an Energy Home. How many things can you find that use energy? Make an X

with a red crayon on the things that you think use more energy than others. Use a blue crayon to draw a line under places that you can save energy. Use a green crayon to draw a line under the places that *your family* can save energy.

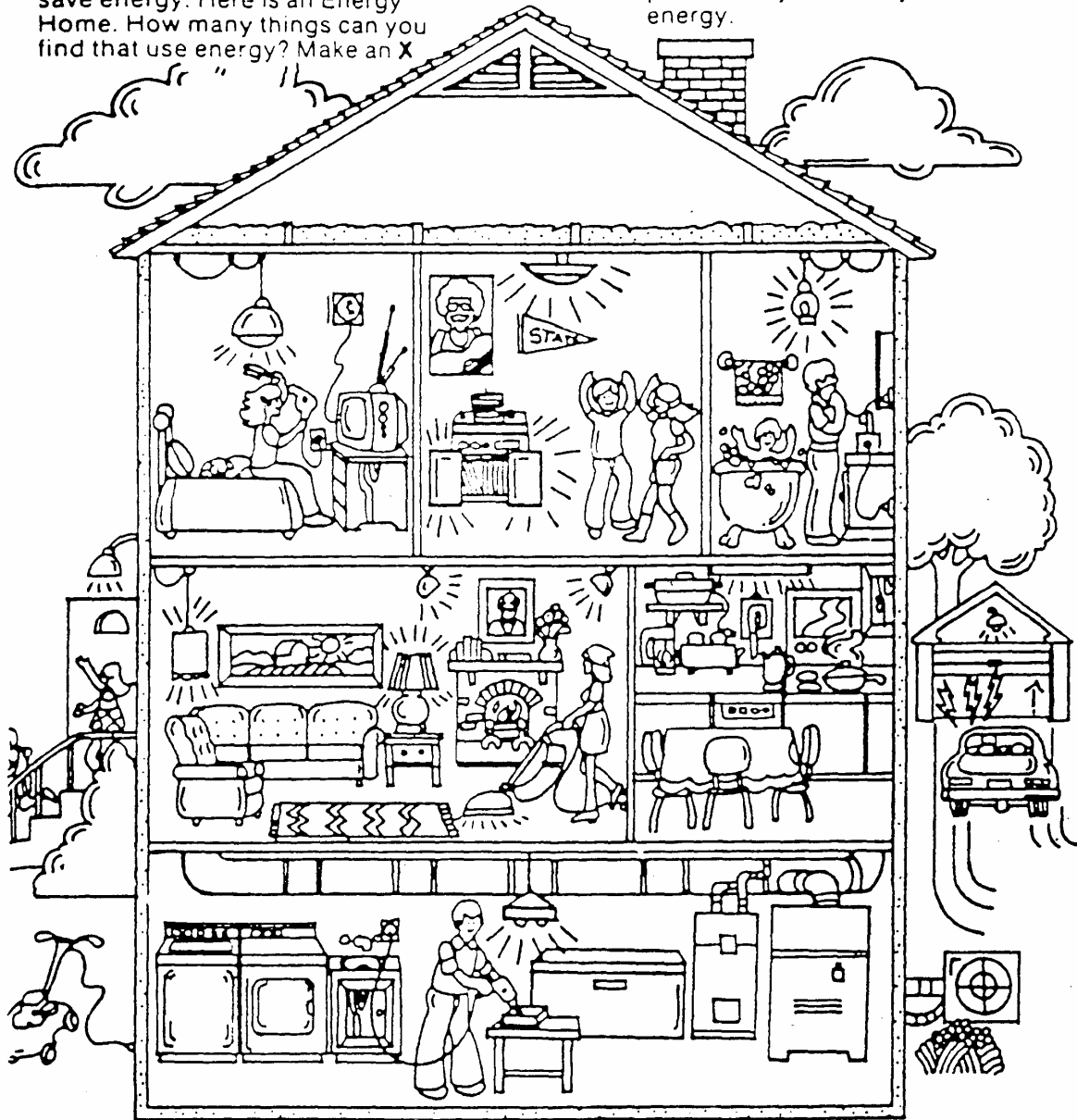

# CUBSERVATION

## April 2004

### Tigers - Our Colorful World/ Conservation

#### Family Activity

##### **FAMILY DISCUSSION**

Has a family talk about the ways people can care for the Earth in the home, school or community?

Name some natural resources found in the school, home or community?

Talk about ways he can help take care of the Earth?

##### **EARTH WALK**

Take the family on an Earth (natural resources) walk around the neighborhood. On the walk:

- ◆ Ask the children to look for things the Earth provides (natural resources).
- ◆ As resources are observed, have the children stop, look at the resources, then use their senses to describe them (what they see, how it feels, what it smells like, how it sounds).
- ◆ Ask the children: "In what ways have people taken care of the natural resources in our neighborhood?"
- ◆ Ask the children: "How have the natural resources in the neighborhood been changed to make life better for people?"
- ◆ If possible, take children to areas where people have not cared for the Earth. (This could be a site with a lot of trash, absence of trees and grass, etc.)
- ◆ Ask the children: "If some natural resources have been damaged, how can we repair or fix them?"
- ◆ Come home and let the children draw a picture showing what they are going to do to help. Hang it for all the family to see and be remind of what they are going to do to help the earth.

#### Den Activity

##### **APPLE BIRDFEEDER**

You'll need one apple, 3 feet of string and birdseed or cereal for each boy. Cut lengthwise grooves in the apple on all four sides. Cut the top off about 1/2-inch from the stem of the apple. Scoop out some of the insides of the apple with a spoon, being careful not to break the skin. Fill the center of the apple with birdseed or cereal. Re-attach the top of the apple to the bottom using the string: criss-cross the string underneath the apple and tie it above the stem. Use the remaining string to hang the apple outside where it will be protected from rain. (Note: you could also use an orange, pear, nectarine or turnip, green tomato, gourd or firm squash.)

# CUBSERVATION

## April 2004

### Tigers - Our Colorful World/ Conservation

#### Den Activity

##### **TRASH MONSTER**

You'll need two paper lunch bags, construction paper, markers, scissors and glue. Cut an oval opening in the bottom of one lunch bag. Open the other lunch bag and slide the first one inside it so the hole is at the top (monster's mouth) and the other bag's bottom is on the bottom. Decorate the bag, as you like with construction paper eyes and accordion-folded arms. Or use markers. Set the monster on a desktop and feed it small pieces of trash!

##### **MILK JUG BIRD FEEDER**

###### **NEED:**

*Gallon milk jug with lid*

*Sharp pointed scissors*

*Pencils*

*Bird seed*

*String, optional*

###### **DIRECTIONS**

Rinse out an empty plastic gallon milk jug with lid.

Dry thoroughly.

Cut a window in the front of the jug, and make two small poke holes for the perches.

Insert pencils for perches and fill the bottom of the jug with birdseed.

You can either rest the bird feeder on a ledge or punch holes near the top, add string, and hang from a branch.

##### **EASTER EGG MOSAICS**

Save all those peeled Easter egg shells to make a mosaic picture.

###### **NEED:**

*Easter egg shells*

*Glue*

*Cardboard or heavy construction paper*

###### **DIRECTIONS:**

Crush all the Easter egg shells into small pieces (not tiny!).

Glue the eggshells down on cardboard or paper to create a mosaic picture.

# CUBSERVATION

## April 2004

### Tigers - Our Colorful World/ Conservation

#### Den Activity

##### WHERE DOES GARBAGE GO

Read the book *Where does garbage go?* up through the part about Americans generating 4 lbs. of trash a day. Ask the boys to name the kinds of things they throw away.

Let the boys hold a bag with four pounds of trash in it to see/feel how much trash it contains (4 lbs.). Line seven bags up in a row to show them how much trash one person makes every week (28 lbs.).

Demonstrate what goes into a landfill. Ask the boys to pretend that the bin (recycle bin) surrounded by a white sheet is a hole in the ground (landfill). More than half of the trash in landfills is paper. Ask a boy to put the paper provided into the landfill. Repeat the procedure with the correct proportions of other landfill trash (glass, metal, plastic, food and yard waste, other).

Read the pages about how many communities now recycle. Why do they recycle? (By recycling, these people to cut down on the amount of trash they send to the landfills. By throwing away less trash, the people help to make the Earth a cleaner place.)

Ask the boys to look at the landfill again and name the things in the landfill that cannot be recycled. After taking out "other" and "food and yard waste," remove the sheet and show them that the pretend landfill is really a recycling bin. All of the items remaining in the bin can be recycled.

Show the boys a poster that shows the recycling symbol ("chasing arrow"). Ask the boys if they have seen these symbols before? Where? What do they mean? Explain that the boys and their partner will now work together. They will be recycling detectives and will look for these symbols on different items in their home to determine if the items can be recycled or not. Explain that not ALL of the objects that can be recycled have the symbol on them (like magazines and some cardboard, etc.), but many of the objects do. Looking for the symbol is a very good way to try and figure out if you can put the object out for the recycling truck or take it to a recycling center. Have them bring their list to the next meeting to share with each other. Have each boy name one thing on their list and continue until all items on each list have been named.

#### Go See It Outing

- ◆ Tour a fast food restaurant or small restaurant
- ◆ Have someone from OSHA or planet safety committee give a talk after touring a manufacturing facility.
- ◆ Tour an energy conservation home
- ◆ Tour a Wildflower center and learn about landscaping that will conserve water
- ◆ Tour Electric plant or company and have them explain ways to save energy
- ◆ Tour the local Water company and ask for ways to conserve water.
- ◆ Tour the Gas company and ask about ways to conserve during winter months.

# CUBSERVATION

## April 2004

### Cubmaster Corner - Reach out to the Community

#### **CUB SCOUTING TEACHES BOYS TO REACH OUT**

Cub Scouting provides opportunities for boys to "reach out" into a wider community while maintaining a link with more secure foundations such as the home, religious organization, and school. It helps boys become full members of their communities as they take part in service projects and other community-related activities. They get to know their community better and recognize the importance of good citizenship.



"Be all that you can be" The United States Army used these words as its recruiting slogan. They captured the feeling that an individual can truly achieve and grow through the Army way of life. These are also words for Scouters to ponder. What a shame it would be to leave a boy behind and not give them an opportunity to achieve all of their potential, because we did not reach out to them.

We have a responsibility to insure that boys in our neighborhood and community have the opportunity to join in this movement. This means that we reach out to them and make the Scouting program available.

Recruiting doesn't just happen. Below you will find some ways to help in your recruitment effort.

### **Boys Recruiting Boys:**

#### **Have a Pack Incentive**

Provide a "prize" to every boy who brings a friend to your Cub Scout "Fun" Recruiting Activity. Recruiting patches are also available in the Center for Scouting Scout Shop.

#### **"Prepare" your Scouts with information**

Provide your Scouts with "mini-pocket" calendars, which they can give to their friends at school showing the activities your pack has planned for the year. You could also provide information on activities that your pack conducted last year. Sell the "Fun" of Scouting to boys.

#### **Uniforms Worn to School**

Have your Scouts wear their Cub Scout uniform to school the day of your "Fun" recruiting activity.

#### **Conduct a "Bring a Buddy" Event**

Boys, who bring a buddy" to a special "bring a buddy" event such as a swimming party, game of bowling, etc could be rewarded with a discounted admission fee to the activity or provided with a special recognition at the event.



# CUBSERVATION

## April 2004

### Cubmaster Corner - Reach out to the Community

#### Adults Recruiting Adults:

##### **Determine which families are currently not in the Pack**

After you determine which families from your school are not in the Pack, assign another member of the Pack to call that family and invite them to your special "Fun" Recruiting Activity. You can use last year's school directory as a guide.

##### **Sell the Parents on the Value of Scouting**

Citizenship training, helping other people, positive adult role models, learning responsibility, etc. are characteristics which all parents want for their children. Let the parents know how Scouting helps children grow up into responsible adults.

##### **Talk to Parents at your School's Open House in the Fall**

Set up a booth or demonstration at your school's open house in August or September. Spend some time talking to parents about the "Values of Scouting" as they attend this school activity. Provide them with list of open positions and the Commitment for that position. I example is shown below.

##### **One Year Commitment Working Primarily With Adults**

Chartered Organization Representative	Committee Chairperson
Treasurer	Secretary
Activities Chairperson	Advancement Chairperson
Membership Chairperson	Pack Newsletter Publisher

##### **One Year Commitment Working Primarily With Youth**

Cubmaster	Assistant Cubmaster
Assistant Cubmaster	Den Leader Coach
Webelos Den Leader	Asst. Webelos Den Ldr
Asst. Webelos Den Ldr	Webelos Den Leader
Asst. Webelos Den Ldr	Asst. Webelos Den Ldr
Bear Den Leader	Asst. Bear Den Leader
Wolf Den Leader	Asst. Wolf Den Leader
Tiger Cub Group Organizer	

##### **One Time Commitment - Plan & Execute Single Activity**

Scouting for Food Coordinator	Pack Fundraising Activity Coordinator
Fall Safe-Bicycling Activity Coordinator	Mid-Year Holiday Party Coordinator

##### **One Time Commitment - Plan & Execute Single Activity**

Scouting for Food Coordinator	Pack Fundraising Activity Coordinator
Fall Safe-Bicycling Activity Coordinator	Mid-Year Holiday Party Coordinator
Pinewood Derby Coordinator	Pinewood Derby Concessions Coordinator
Blue and Gold Banquet Coordinator	Friends of Scouting Coordinator
Spring Picnic Coordinator	Scout Show Coordinator
Scout Show Ticket Sales Coordinator	Cub Scout Day Camp Coordinator
Webelos Resident Camp Coordinator	Summertime Activities Coordinator

*And of course you can always add a few of your own depending on your activities; e.g. Rain-gutter Regatta Skipper, etc.*

# MY HOME STATE

May 2004



What is special about your state? This month we'll find out. Cub Scouts will visit historic places, theme parks, museums, and zoos. Choose a city or a historical site in your state to highlight. Design a game that features some special aspect of your home state. Take a trip, go to a ball game, or just have a family picnic in the park. Pretend you are someone important in the history of your state, and see if anyone can guess who it is! Put on a skit where each den pretends to be doing something that is common in your state, and see if the audience can guess what it is! How about some special recipes that each den can prepare to be shared at the pack meeting? Invite a guest speaker who can share something special about your state with the boys. Use maps or collect tourist brochures to learn more about places to visit. Your local historical society or public library is a great place to get started.

## NOTE –

*This section is different from most other months. Not all topics are covered but there is a lot of New Jersey information to use. You may want to use classic skits, songs, and ceremonies from other months or other resources this month.*

Cub Scout Theme .....	03
Webelos – Outdoorsman .....	23
Webelos – Handyman.....	30
Tigers - Picnic Fun/ Fun Outdoors .....	33
Cubmaster Corner - Year Round Program.....	35

# MY HOME STATE

## May 2004

### The Blessing in "NO"

I asked God to take away my pride.  
God said "No".  
It is not for me to take away, but for you to give it up.

I asked God to make my handicapped child whole.  
God said "No".  
Her spirit was whole, her body was only temporary.

I asked God to grant me patience.  
God said "No".  
Patience is a by-product of tribulations; it isn't granted, it is earned.

I asked God to give me happiness.  
God said "No".  
I give you blessings, happiness is up to you.

I asked God to spare me pain.  
God said "No".  
Suffering draws you apart from worldly cares and brings you closer to me.

I asked God to make my spirit grow.  
God said "No".  
You must grow on your own, but I will prune you to make you fruitful.

I asked for all things that I might enjoy life.  
God said "No".  
I will give you life so that you may enjoy all things.

I ask God to help me LOVE others, as much as he loves Me.  
God said... Ahhhh, finally you have the idea!

Author Unknown  
From Circle Ten Pow Wow

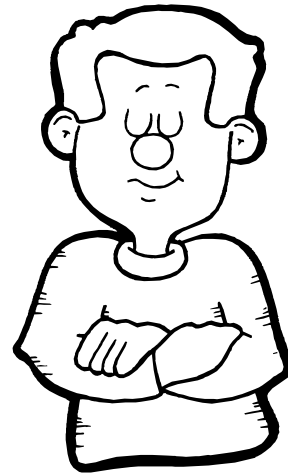

# MY HOME STATE

## May 2004

### Gathering Activities

#### KNOW YOUR STATE

Draw a line to the correct answer to the questions asked below.

- |  |                     |
|--|---------------------|
| 1. What is the capital of New Jersey?                      | Eastern Goldfinch   |
| 2. What river forms New Jersey western border?             | Sussex County       |
| 3. What is the state dinosaur of New Jersey?               | Rutgers             |
| 4. In what city do they hold the Miss America contest?     | Violet              |
| 5. What is the name of the state bird of New Jersey?       | Atlantic City       |
| 6. What flower represents the state of New Jersey?         | Hadrosaurus Foulkii |
| 7. What is the State University called?                    | Delaware            |
| 8. Where would you go to attend the New Jersey state fair? | Trenton             |

#### FAMOUS PEOPLE FROM NEW JERSEY (or associated with New Jersey)

- |                         |   |
|-------------------------|---|
| 1. William "Bud" Abbott | A. Wrote "The Red Badge of Courage"                               |
| 2. Jason Alexander      | B. Old Blue Eyes  |
| 3. John Forsythe        | C. The Wizard of Menlo Park, invented light bulb                  |
| 4. Bruce Willis         | D. President of Princeton before President of US                  |
| 5. Jerry Lewis          | E. The Labor Day telecast emcee                                   |
| 6. Ozzie Nelson         | F. NY Yankee player   |
| 7. Stephen Crane        | G. Son of founder of NJ State police, US Army General             |
| 8. Joyce Kilmer         | H. Half of famous comedy team                                     |
| 9. Frank Sinatra        | I. One of two actors associated with Penns Grove, NJ              |
| 10. Bruce Springsteen   | J. Only US President with two non-consecutive terms               |
| 11. Frankie Valli       | K. The Four Seasons lead singer                                   |
| 12. Derek Jeter         | L. Wrote the poem "Trees"   |
| 13. Edwin "Buzz" Aldrin | M. Member of Seinfeld cast  |
| 14. Wally Schirra       | N. Only Astronaut in all three programs – Mercury, Gemini, Apollo |
| 15. Grover Cleveland    | O. The Boss   |
| 16. Woodrow Wilson      | P. Second man on the moon   |
| 17. Norman Schwarzkopf  | Q. The other Penns Grove, NJ, actor                               |
| 18. Thomas Edison       | R. Put his family on TV   |

# MY HOME STATE

## May 2004

ANSWERS to "KNOW YOUR STATE" –

1. Trenton, 2. Delaware, 3. Hadrosaurus Foulkii, 4. Atlantic City, 5. Eastern Goldfinch, 6. Violet, 7. Rutgers, 8. Sussex County

Answers to "FAMOUS PEOPLE FROM NJ" –

1H, 2M, 3Q, 4I, 5E, 6R, 7A, 8L, 9B, 10O, 11K, 12F, 13P, 14N, 15J, 16D, 17G, 18C

### Openings

#### ALL ACROSS OUR NATION

*Personnel: 8 Cub Scouts*

*Equipment: Picture of or a small flag. The following pictures: Statue of Liberty, steel mills or factory, scene of New Jersey, picture of the Alamo, picture of Alaska, Hawaiian scene, map or picture of the U.S.A. Recorded background music.*

The Cub Scouts form a semi-circle around the flag and hold up their picture and say the short verse.

1st Cub: (Statue of Liberty) New York is a lovely state where we see this lady stand.

2nd Cub: (factory or industry) Michigan is a very great state, they make many cars for our land.

3rd Cub: (New Jersey scene) New Jersey is our own home state, we're proud in many ways.

4rd Cub: (Alamo scene) Texas is the Lone Star state, home to the Alamo.

5th Cub: (Alaskan scene) Alaska has some very cold nights, with some short, short days.

6th Cub: (Hawaiian picture) Hawaii is our newest state, and we're proud to say she's ours.

7th Cub: (map or picture U.S.) But all of the states together, make a nation of beautiful stars.

8th Cub: (Flag) Please join me in singing "God Bless America."

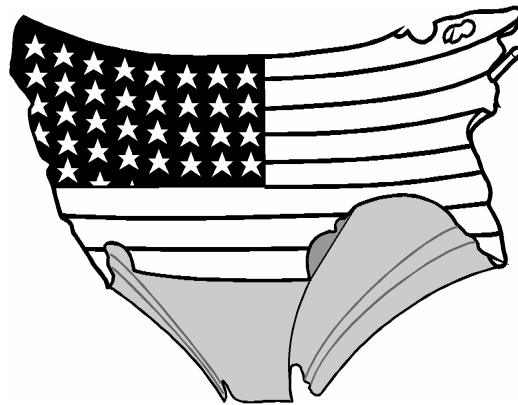

#### NEW JERSEY CUB SCOUTS

The US Flag and a pack flag are carried to the front by the color guards. They face the audience. The lights are turned down and a Cub Scout stands in between the flags. A spotlight is turned on the setting. A good reader, reads the verse below.

He's just eight years old

He's made of the following ingredients: Noise, energy, imagination, curiosity and hunger.

He's the "cute little boy down the street", That "spoiled imp next door", or "My Son,"... depending on who you are.

He's something to be kept fed, clothed, healthy, happy and out of trouble.

But.....

He's something else, too.....

He's tomorrow. He's the future we've been fighting for.

He's part of the world's most important generation.

The generation who must carry on after us and win the peace.

# MY HOME STATE

## May 2004

### Den Activities

#### Scavenger Hunt

The answers to the 20 questions in this Scavenger Hunt can be found on the NJ Hangout Web pages designed for Kids. Check your [answers](#) when you are done, and print out your certificate.

[http://www.state.nj.us/hangout\\_nj/assignment\\_timeline.html](http://www.state.nj.us/hangout_nj/assignment_timeline.html)  
[http://www.state.nj.us/hangout\\_nj/government\\_statehouse.html](http://www.state.nj.us/hangout_nj/government_statehouse.html)  
[http://www.state.nj.us/hangout\\_nj/cartoonhistory\\_hadro.html](http://www.state.nj.us/hangout_nj/cartoonhistory_hadro.html)  
[http://www.state.nj.us/hangout\\_nj/government\\_judicial.html](http://www.state.nj.us/hangout_nj/government_judicial.html)  
[http://www.state.nj.us/hangout\\_nj/government\\_legislative.html](http://www.state.nj.us/hangout_nj/government_legislative.html)  
[http://www.state.nj.us/hangout\\_nj/government\\_governors.html](http://www.state.nj.us/hangout_nj/government_governors.html)  
[http://www.state.nj.us/hangout\\_nj/200202\\_jersey\\_devil\\_p1.html](http://www.state.nj.us/hangout_nj/200202_jersey_devil_p1.html)  
[http://www.state.nj.us/hangout\\_nj/government.html](http://www.state.nj.us/hangout_nj/government.html)  
[http://www.state.nj.us/hangout\\_nj/assignment\\_symbols.html](http://www.state.nj.us/hangout_nj/assignment_symbols.html)  
[http://www.state.nj.us/hangout\\_nj/travel\\_ski.html](http://www.state.nj.us/hangout_nj/travel_ski.html)  
[http://www.state.nj.us/hangout\\_nj/assignment\\_facts.html](http://www.state.nj.us/hangout_nj/assignment_facts.html)

#### Questions

1. Who discovered the New Jersey state dinosaur, the Hadrosaurus Foulkii?
2. When was New Jersey's first constitution written?
3. New Jersey's four ski lodges are Hidden Valley, Campgaw Mountain, High Point Cross Country Ski Center, and \_\_\_\_\_.
4. In what year did Thomas Edison open his laboratory in Menlo Park?
5. How many pieces of gold leaf cover the State House dome?
6. Who was named first royal governor of New Jersey in 1703?
7. Who designed the original State House that was built in 1792?
8. What is the highest court in the judiciary branch?
9. How many people are in the state Senate?
10. What do locals in the Pine Barrens call the Jersey Devil?
11. What is New Jersey's state bird?
12. What was the population of New Jersey in 2000?
13. Where was Grover Cleveland born?
14. How old must you be to become a state senator?
15. In what year was the Jersey Devil said to be born to Mother Leeds?
16. In what year was the Hadrosaurus Foulkii discovered?
17. When did today's state constitution come into effect?
18. How many people are in the General Assembly?
19. What is New Jersey's official flower?
20. What was New Jersey's first newspaper?

# MY HOME STATE

## May 2004

### Answers to Scavenger Hunt

- |                          |                    |
|--------------------------|--------------------|
| 1. William Parker Foulke | 2. 1776            |
| 3. Mountain Creek        | 4. 1876            |
| 5. 48,000                | 6. Edward Hyde     |
| 7. Jonathan Doane        | 8. Supreme Court   |
| 9. 40                    | 10. Leeds Devil    |
| 11. Eastern Goldfinch    | 12. 8,414,350      |
| 13. Caldwell             | 14. 30             |
| 15. 1735                 | 16. 1858           |
| 17. 1947                 | 18. 80             |
| 19. Violet               | 20. Jersey Gazette |

*If you take the quiz on-line at*

[http://www.state.nj.us/hangout\\_nj/njkids\\_scavenger.html](http://www.state.nj.us/hangout_nj/njkids_scavenger.html),

*the computer will print a fancy certificate!!!*

## New Jersey Historical Sites

The DEP's Division of Parks and Forestry 57 historic sites and districts, and more than 24,000 museum objects and 68,000 archaeological artifacts. These historic resources span the 15th through 20th centuries and include Lenape Native American lands, Revolutionary War battlefields, lighthouses, a presidential birthplace, the home of Walt Whitman and five historic villages.

New Jersey's state historic sites are open year round, Wednesday through Sunday from 10 a.m. to noon and from 1 p.m. to 4 p.m., although times may vary. Sites are closed Wednesdays following Monday holidays. For specific hours, please call the historic site you wish to visit. Sites open to the public are listed below.

For more information on New Jersey's State historic sites or parks, call (800) 843-6420 or (609) 984-0370. Text telephone users: call NJ Relay Services at (800) 852-7899.

Here are one's near our area.

For a complete list go to <http://www.state.nj.us/dep/parksandforests/historic/index.html>

**Allaire Village, [Allaire State Park](#), P.O. Box 220, Farmingdale NJ 07727, (732) 938-2371**

Allaire State Park is best known for Allaire Village, a well-preserved early 19th-century ironmaking town with a general store, blacksmith shop, carpenter's shop, owner's house, foreman's house, church, and museum.

**Barnegat Lighthouse, [Barnegat Lighthouse State Park](#), Barnegat Light NJ 08006, (609) 494-2016**

The site of Barnegat Lighthouse on the northern tip of Long Beach Island in Ocean County was regarded as one of the most crucial "change of course" points for coastal vessels. A panoramic view of Island Beach, Barnegat Bay and Long Beach Island awaits visitors to the top of the lighthouse.

**Batsto Village, [Wharton State Forest](#), Batsto, RD. #9, Hammonton NJ 08037, (609) 561-0024**

This Pine Barrens village is composed of thirty-three historic buildings and structures including the Batsto Mansion, gristmill, sawmill, general store, workers' homes and post office. Batsto Village was a former bog iron and glassmaking industrial center from 1766 to 1867 and currently reflects the agricultural and commercial enterprises that existed here during the late 19th century.

# MY HOME STATE

## May 2004

### New Jersey Historical Sites

**Cape May Lighthouse, [Cape May Point State Park](#), Cape May Point NJ 08212, (609) 884-2159**

The 157-foot high lighthouse is still an aid to navigation. Visitors who climb to the top of the lighthouse can view the constantly changing Cape May peninsula shoreline. The first known lighthouse at Cape May was built in 1823, but had to be moved. The present lighthouse was built in 1859.

**Central Railroad of New Jersey Terminal, [Liberty State Park](#), Jersey City NJ 07305, (201) 915-3400**

From 1892 through 1954, the CRRNJ Terminal stood with the Statue of Liberty and Ellis Island to unfold one of this nation's most dramatic stories: the immigration of northern, southern and eastern Europeans, among others, into the United States. After being greeted by the Statue of Liberty and processed at Ellis Island, these immigrants purchased tickets and boarded trains at the Terminal to their new homes.

**[Delaware & Raritan Canal State Park](#) - Blackwells Mills Canal House, Mule Tenders Barracks, Port Mercer Canal House, Prallsville Mills, 625 Canal Road, Somerset NJ 08873, (732) 873-3050**

Most of the old canal system remains intact today and is a reminder of the days when the delivery of freight depended upon a team of mules or steam tugboats. Nearly 36 miles of the main canal and 22 miles of the feeder canal still exist, with many historic structures along the canal.

**Double Trouble Village, [Double Trouble State Park](#), Seaside Park NJ 08752, (732) 793-0506**

Fourteen original historic structures dating from the late 19th century through the early 20th century include a general store, a schoolhouse and cottages. The sawmill was restored in 1995, and the cranberry sorting and packing house was completed in 1996.

**Fort Mott, [Fort Mott State Park](#), 454 Fort Mott Road, Pennsville, NJ 08070, (856) 935-3218**

Fort Mott was part of a coastal defense system designed for the Delaware River in the late 1800's. The fortifications seen today at Fort Mott were erected in 1896 in anticipation of the Spanish-American War.

**Grover Cleveland Birthplace, 207 Bloomfield Avenue, Caldwell NJ 07006, (973)226-0001**

In 1837, Grover Cleveland was born in this house while his father, the Reverend Richard Falley Cleveland, was the minister to the First Presbyterian Church of Caldwell. Most of the first floor rooms portray the house as it was in 1837.

**Hancock House, 3 Front Street, Hancock's Bridge NJ 08038, (856) 935-4373**

Judge William Hancock built this brick house in 1734. A notable feature is the decorative patterned brickwork on the end wall of the house.

**[Indian King Tavern](#), 233 Kings Highway, Haddonfield NJ 08033, (856) 429-6792**

On March 10, 1777, the New Jersey Assembly met at the Indian King Tavern and approved the adoption of the Great Seal of New Jersey. Six months later, the Assembly met again at the tavern and enacted a law substituting the word "state" for "colony" in all commissions, writs and indictments.

**Johnson Ferry House, [Washington Crossing State Park](#), 355 Washington Crossing-Pennington Road, Titusville NJ 08560, (609) 737-2515**

This early 18th-century gambrel roof farmhouse and tavern near the Delaware River was owned by Garret Johnson, who operated a 490-acre colonial plantation and a ferry service across the river in the 1700s.

**Long Pond Ironworks Historic District,**

**[Rockingham](#), PO Box 496, Kingston NJ 08528, (609) 921-8835**

In 1783, while the Continental Congress was meeting at Nassau Hall in nearby Princeton, Congress rented the house from the widow of Judge John Berrien for use by General George Washington from August 23 to November 10, 1783. Martha Washington joined him at Rockingham. Rockingham is currently closed for restoration.

**Somers Mansion, 1000 Shore Road, Somers Point NJ 08244, (609) 927-2212**

Somers Mansion was built about 1725 by Richard Somers and is the oldest existing house in Atlantic County. Somers operated the first ferry across Great Egg Harbor Bay.



# MY HOME STATE

May 2004

## New Jersey Historical Sites

**Trenton Battle Monument, Administered by [Washington Crossing State Park](#), 348 South Warren Street, Trenton NJ 08638, (609) 737-0623**

The monument marks the site of the American artillery emplacement that commanded the streets of Trenton during the battle that led to the defeat of the three Hessian Regiments by the American Army at the Battle of Trenton, December 26, 1776. The monument was designed by John H. Duncan, architect of Grant's tomb. (Combine this with a trip to the New Jersey State Museum!!)

**[Walt Whitman House](#), 330 Mickle Boulevard, Camden NJ 08103, (856) 964-5383**

The renowned poet lived in this house from 1884 until his death in 1892, and received many visitors during that time including the painter Thomas Eakins, naturalist John Burroughs and writers Oscar Wilde and Bram Stoker. The house is furnished with a number of pieces owned and used by Whitman.

**Washington Crossing, [Washington Crossing State Park](#), 355 Washington Crossing-Pennington Road, Titusville NJ 08560, (609) 737-9303**

After crossing the icy waters of the Delaware River on December 25, 1776, General George Washington and the Continental Army landed at Johnson's Ferry, at the site now known as Washington Crossing State Park.

**Whitesbog Village, [Brendan T. Byrne State Forest](#), New Lisbon NJ 08064, (609) 726-1191**

Whitesbog was an active 19th- and 20th-century cranberry and blueberry producing community, founded in the 1870's by Joseph J. White. The commercial high-bush blueberry was developed here by Elizabeth White. The site is undergoing restoration and is leased to the Whitesbog Preservation Trust.

## NEW JERSEY STATE PARKS AND FOREST

### Parks and Forests of the Delaware River Region

- A. **[Princeton Battlefield](#)**
- B. **[Washington Crossing](#)**
- C. **[Rancocas](#)**
- D. **[Byrne](#)** (formerly Lebanon)
- E. **[Wharton](#)**
- F. **[Penn](#)**
- G. **[Bass River](#)**
- H. **[Parvin](#)**
- I. **[Fort Mott](#)**



## NEW JERSEY STATE PARKS AND FOREST

# MY HOME STATE

## May 2004

### Parks, Forests, and Marinas of the Southern Shore Region

- A. Belleplain
- B. Fortescue Marina
- C. Corson's Inlet (administered by Belleplain)
- D. Cape May Point

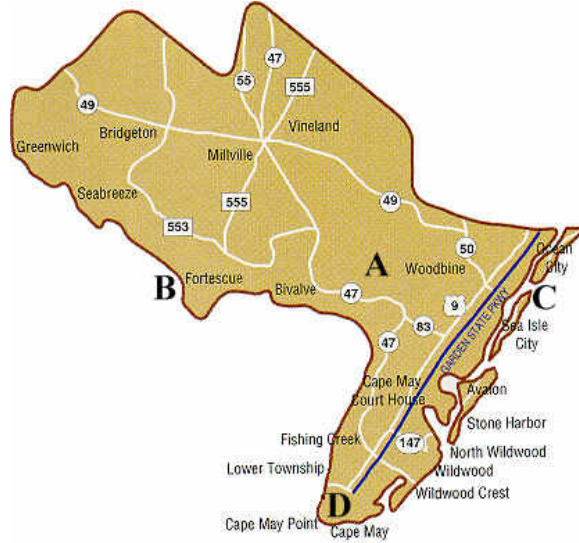

### Forests and Marinas of the Greater Atlantic Region

- A. Wharton
- B. Farley Marina

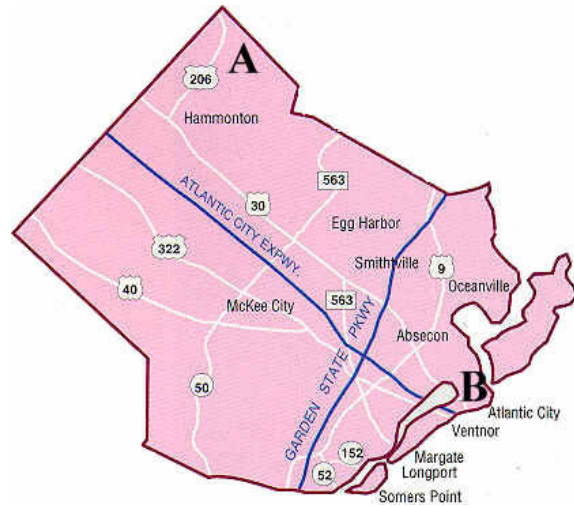

# MY HOME STATE

## May 2004

### New Jersey Teams

Match these New Jersey teams to their sports and their stadiums -

TEAM	SPORT	STADIUM or ARENA
<a href="#">Atlantic City Surf</a>	_____	_____
<a href="#">Camden River Sharks</a>	_____	_____
<a href="#">NJ Devils</a>	_____	_____
<a href="#">NY Giants</a>	_____	_____
<a href="#">Gladiator Arena Football</a>	_____	_____
<a href="#">NY Jets</a>	_____	_____
<a href="#">Lakewood Blue Claws</a>	_____	_____
<a href="#">NY-NJ Metrostars</a>	_____	_____
<a href="#">NJ Nets</a>	_____	_____
<a href="#">Newark Bears</a>	_____	_____
<a href="#">NJ Cardinals</a>	_____	_____
<a href="#">Somerset Patriots</a>	_____	_____
<a href="#">Trenton Thunder</a>	_____	_____
<a href="#">Trenton Titans</a>	_____	_____

Here are some ideas for stadiums and arenas in New Jersey. The answers may or may not be here. This list is not complete.

Check out <http://www.state.nj.us/Attractions,+Arts,+Sports,+Recreation.html> for more

Continental Airlines Arena	Freehold Raceway	Giants Stadium
Meadowlands	Campbell's Field	Mercer County Waterfront
Monmouth Park	Raceway Park	Riverfront Stadium
Sandcastle Stadium	Tweeter Center	Sovereign Bank Arena

# MY HOME STATE

## May 2004

### Museum Links

How many museums can you fit in one state? A whole bunch! Check out some of the great museums New Jersey has to offer.

- [New Jersey State Museum](#)
- [Liberty Science Center](#)
- [Air Victory Museum](#)
- [Morris Museum](#)
- [Battleship New Jersey Historical Museum Society](#)
- [The Newark Museum](#)
- [Society of African Missions - The Tenafly Museum of African Art](#)
- [Montclair Art Museum](#)
- [New Jersey Museum of Agriculture](#)
- [Museum of American Glass](#)
- [The Art Museum, Princeton University](#)
- [The Bergen Museum](#)
- [Atlantic City Historical Museum](#)

### Welcome To The New Jersey State Museum

From fossils to fine art, from Native American tools to the finest silver, from quilts to comets, from prehistory to the future, the New Jersey State Museum is four museums in one and offers a galaxy of experiences for every member of the family. Treasures, collected since the early 1800's, are housed in a modern main building overlooking the Delaware River in Trenton and are enhanced by exciting programs offered in an adjoining 150-seat planetarium and an adjacent 400-seat auditorium. General admission is free.

### Planetarium at the New Jersey State Museum

The New Jersey State Museum invites visitors to soar through the skies in its modern, spacious 150-seat Planetarium. A state-of-the-art Minolta MS-10 instrument and hundreds of auxiliary devices for video projections, enable production of a wide range of realistic and exciting sky shows as well as virtual recreations of the solar system. Backlit dioramas of the constellations, models of the solar system and the technology of space exploration, are featured in astronomy exhibits. The Planetarium Gallery offers exhibitions on extended view. Kaleidoscope Kids

### Kaleidoscope Kids at the New Jersey State Museum

*Workshops at 2 and repeated at 3 pm - \$3 per child*

*Sundays, February 1, 8, 16, 22, and 29, 2004, Sundays, March 7, 14, 21, and 28, 2004*

*Sundays, April 4, 18, and 25, 2004 (No class on April 11)*

*\$3.00 per child per afternoon, Pre-registration recommended (609) 292-6310*

The State Museum's Kaleidoscope Kids family education program features weekend classes for young people ages 6 to 12 (parents are welcome, too!) and a Kaleidoscope Kids Summer Academy. Kaleidoscope Kids helps young people pursue interests as *Young Scientists* (kids who like to do experiments and learn about dinosaurs and the physical and natural world), *Young Explorers* (for kids who want to be archaeologists, study history or learn about the past), and *Young Ambassadors* (for kids who want to travel the world, meet new people and learn about other cultures). Children may participate in an entire afternoon of programs for \$3.

# MY HOME STATE

## May 2004

### Wheaton Village

From <http://www.wheatonvillage.org/>

In its daily operations, Wheaton Village is a leading resource of American craft with an emphasis on the medium of glass, a stronghold in New Jersey's cultural history. Programs include museum and gallery exhibits; interpretive demonstrations in various craft mediums; an artist fellowship program; outreach and on-site school programs; and collector's seminars. All serve to educate a multi-level audience on the role of the crafts in both traditional and contemporary life.

Programs are presented in the following facilities at Wheaton Village:

**[The Museum of American Glass](#)** houses one of the world's largest collections of American glass. Over 6,500 pieces are on display in the 20,000 square foot exhibit area. An annual major exhibit is presented by the Museum from May through October. Other special exhibits are also presented during the year

**[The Glass Studio in the T. C. Wheaton Glass Factory](#)** is a fully functioning glass studio architecturally modeled after the original 1888 factory. Studio artists using both traditional and contemporary techniques work side by side in this studio, recognized throughout the country as a valuable resource to the glass art community.

**Crafts Studios:** Ceramics, Flameworked Glass, Woodcarving and Tinsmithing are demonstrated and interpreted to visitors by skilled artists.

**[The Down Jersey Folklife Center](#)** researches and documents regional expressive traditions in New Jersey's southern eight counties. The Center will present ongoing programs based on this research for a wide variety of audiences.

**[The Gallery of Fine Craft](#)** is dedicated to excellence in the development of studio glass art and regional craft through the representation of established and emerging artists. As an extension of educational programming, one to two shows per year will exhibit elementary, secondary or college student's work.

### ***SPECIAL PROGRAMS***

**kids pARTicipate:** This October program celebrates "National Arts and Humanities Month" in New Jersey. The program offers free hands-on workshops in a variety of crafts such as glassblowing, ceramics, paper-making, stained glass, woodworking and leather. About 300 students are expected to attend in 2000.

**Student Docent Tours:** Grade level, curriculum related tours of the Museum of American Glass for elementary classes, grades 4 - 12. Communication with the museum staff gives a teacher the option of relating the tour to specific curriculum involving a specific time period of study, as well as art and NJ history.

**[Make Your Own Paperweight:](#)** With the guidance of our master glass artists, visitors have an opportunity to use molten glass to create their own paperweight. (Additional fee charged)

# MY HOME STATE

## May 2004

### Famous Firsts in New Jersey

- The first organized baseball game was played in Hoboken in 1846.
- The first boardwalk in the world was built in 1870 at Atlantic City.
- The first drive-in movie theater was built on a 10-acre plot in Camden County in 1933.
- The first ferry service in the U.S. operated between Hoboken and Manhattan in 1811.
- The first seashore resorts opened in Cape May and Long Branch in the early 1800s.
- The first Miss America was chosen in Atlantic City in 1921.
- The first movie was developed by Thomas A. Edison in West Orange in 1889.
- The first phonograph was made by Thomas A. Edison in Menlo Park in 1877.
- The first balloon flight in America was made by Jean-Pierre Blanchard. On January 9, 1793, he landed a balloon at **Deptford** carrying a letter from George Washington.
- The first professional basketball game was played in Trenton in 1896.
- The first incandescent lamp (light bulb) was made by Thomas A. Edison in Menlo Park in 1879.
- The first submarine was built in 1878 by John Holland of Passaic County. The submarine is now in a public museum in Paterson.
- The first condensed soup in America was cooked and canned in Camden County in 1897.
- The first saltwater taffy was produced at the Jersey shore in the 1870s.
- The first solid body electric guitar was invented by Les Paul of Mahwah in 1940.
- The first national historic park in America was established in 1933 in Morristown.
- The first cultivated blueberries were marketed by Elizabeth White of Whitesbog in 1916.
- The first steam locomotive to actually pull a train on a track was built by John Stevens of Hoboken in 1824.
- The first town to be lighted by electricity was Roselle in 1883.
- The first radio broadcast of the World Series was transmitted live on radio station WIZ in Newark in 1921.
- The first intercollegiate football game was played by Rutgers and Princeton in New Brunswick on November 6, 1869. Rutgers won 6 to 4.
- The first [airplane passenger flight](#) flew from New York to Atlantic City on May 3, 1919.

# MY HOME STATE

## May 2004

**You're a genuine New Jerseyan,  
if you recognize or can relate to at least 10 of these...**

from <http://community-2.webtv.net/klmerritt/NewJerseyan/>

You know that the only people who call it "Joisey" are from the Bronx or Texas.

You don't think of citrus when people mention "The Oranges."

You know that it's called "Great Adventure," not "Six Flags."

You've ordered a hard roll with butter for breakfast.

You've known the way to Seaside Heights since you were seven.

You've eaten at a diner, after partying, at 3 am.

You remember that the "Two Guys" were from Harrison.

You know that the state isn't one big oil refinery.

At least three people in your family still love Bruce Springsteen,

You know what town Jon Bon Jovi is from.

You know what a "jug handle" is.

You know that a WaWa is a convenience store.

You know that the state isn't all farmland.

You know that there are no "beaches" in New Jersey - there's "The Shore," & you know that the road to the shore is "The Parkway" - not "The Garden State Highway."

You know that "Piney" isn't referring to a tree.

Even your school cafeteria made good Italian subs, & you call it a "sub" not a "submarine sandwich" or worse yet, a "hoagy" or a "hero."

You remember the song from the Palisades Park commercials.

You know how to properly negotiate a Circle.

You knew that the last question had to do with driving.

You know that "Acme" is an actual store, not just a Warner Bros. creation.

You know that this is the only "New..." state that doesn't require "New" to identify it like, try... Mexico, ... York, ... Hampshire (doesn't work, does it?).

You only go to New York City for day trips, & you only call it "The City."

You know that a "White Castle" is the name of BOTH a fast food chain AND a sandwich.

You don't think "What exit" (do you live near?) is very funny.

You know that people from 609 area code are "a little different."

You know that no respectable New Jerseyan goes to Princeton - that's for out-of-staters.

The Jets-Giants game has started fights at your school or work place.

You live within 20 minutes of at least three different malls.

You refer to all highways & interstates by their numbers.

Every year, you had at least one kid in your class named Tony.

You know where every "clip" shown in the Sopranos opening credits is.

You've eaten a Boardwalk cheesesteak with vinegar fries.

You start planning for Memorial Day weekend in February.

You know that "youse" is not a synonym for utilize but for y'all.

And finally... you've never pumped your own gas.

# MY HOME STATE

## May 2004

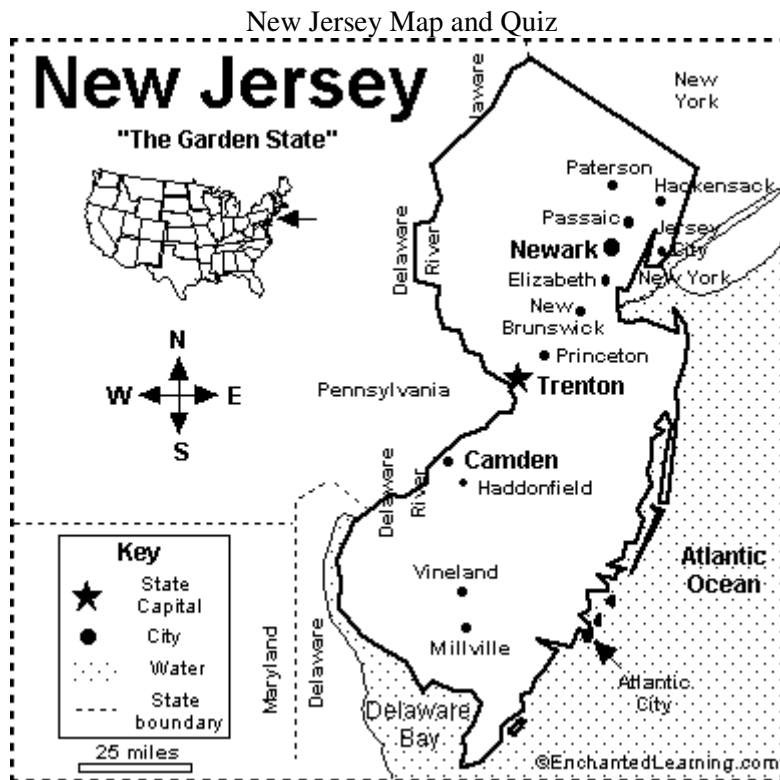

### New Jersey Map and Quiz

From <http://www.enchantedlearning.com/usa/statesbw/newjersey.shtml>

1. What is the capital of New Jersey? \_\_\_\_\_
2. Which state borders New Jersey on the northeast? \_\_\_\_\_
3. What two states border New Jersey on the west? \_\_\_\_\_ and \_\_\_\_\_
4. What ocean borders New Jersey on the southeast? \_\_\_\_\_
5. What is the name of the bay on the southwestern shore of New Jersey? \_\_\_\_\_
6. On Christmas night in 1776, George Washington crossed a river near Trenton and defeated soldiers fighting for the British. This river forms the western border of New Jersey. What is the name of this river?  
\_\_\_\_\_
7. What is the name of the resort city on the southeast shore of New Jersey?  
\_\_\_\_\_
8. Some of the first dinosaur fossils in the USA were found in Haddonfield, New Jersey. Which large New Jersey city is close to Haddonfield? \_\_\_\_\_
9. In which part of the USA is New Jersey located: northeast, southeast, northwest, or southwest?  
\_\_\_\_\_
10. What is New Jersey's nickname? \_\_\_\_\_



# MY HOME STATE

## May 2004

### New Jersey Map and Quiz Answers

- |                              |                      |
|------------------------------|----------------------|
| 1. Trenton                   | 6. Delaware River    |
| 2. New York                  | 7. Atlantic City     |
| 3. Pennsylvania and Delaware | 8. Camden            |
| 4. Atlantic Ocean            | 9. northeast         |
| 5. Delaware Bay              | 10. The Garden State |



New Jersey's official state flag was adopted on March 26, 1896.

The flag has a buff (light yellow-brown) background; this is the color of part of the uniform selected by General [George Washington](#) in 1779 for his New Jersey Continental Line. Part of the state seal (which was designed by Pierre Eugene de Simitiere in 1777) is in the center. In the center is a blue shield with three plows in it. On the sides of the shield are the goddess of liberty (holding a staff and the cap of freedom) and the goddess of agriculture (holding a cornucopia filled with food). Above this is the head armor of a knight, a horse's head, and blue filigrees. Below are the words "LIBERTY AND PROSPERITY" and the date "1776." The goddesses symbolize liberty and prosperity.

New Jersey was the 3rd state in the USA; it became a state in 1787.

#### Questions:

1. When did New Jersey become a state? \_\_\_\_\_
2. In this flag, what does the cap on the staff (pole) symbolize? \_\_\_\_\_
3. The goddesses on this flag symbolize what motto? \_\_\_\_\_

# MY HOME STATE

## May 2004

Songs



### **New Jersey Weather**

*Tune: Battle Hymn of the Republic*

I have seen the sky in darkness, I have seen it in the sun,  
I have felt the rain upon me, I've enjoyed the snowy fun.  
When the weather isn't cloudy or the wind it doesn't blow.  
It isn't only raining, it's the weekend too, you know.  
Glory, glory, it's Jersey weather! [Repeat.]  
I can tell because it's raining and it's 42 below,  
As the Pack goes marching on.

### **A NEW JERSEY STATE SONG**

"I'm From New Jersey" is a State Song written especially for and dedicated to the State of New Jersey. It is a song that is also adaptable to any municipality having a name with two or three syllables. 3 Full-Band Versions, 20 Adapted Versions with Printable Sheet Music, a Printable Vocal - Keyboard and March Band Arrangement, a Sing-along Version, a musical toast to Frank Sinatra, and a Library are accessible by clicking on proper links below. Sands Music published "I'm from New Jersey" in 1961

If you want to hear it, go to –

<http://www.njstatesong.com>

and they have the words, music and a midi file of the tune

### ***I'm From New Jersey***

*Words and Music by **Red Mascara**, (908)-454-6585*

This song is in the Pow Wow book in accordance with this note on the [www.njstatesong.com](http://www.njstatesong.com) website -  
"It is permissible to use I'm From New Jersey or any adapted version as a theme song for school activities, municipal celebrations, or other special events"

#### **Verse (Ad lib)**

I know of a state that's a perfect playland with white sandy beaches by the sea;  
With fun-filled mountains, lakes and parks, and folks with hospitality;  
With historic towns where battles were fought, and presidents have made their home;  
It's called New Jersey, and I toast and tout it wherever I may roam. 'Cause . . .

#### **First Chorus**

I'M FROM NEW JERSEY and I'm proud about it, I love the Garden State.  
I'M FROM NEW JERSEY and I want to shout it, I think it's simply great.  
All of the other states throughout the nation may mean a lot to some;  
But I wouldn't want another, Jersey is like no other, I'm glad that's where I'm from.

#### **Second Chorus**

If you want glamour, try Atlantic City or Wildwood by the sea;  
Then there is Trenton, Princeton, and Fort Monmouth, they all made history.  
Each little town has got that certain something, from High Point to Cape May;  
And some place like Mantoloking, Phillipsburg, or Hoboken will steal your heart away.

# MY HOME STATE

## May 2004

### Skits

#### TYPICAL NEW JERSEY WEATHER

*Props: TV Screen, New Jersey map, Pointer, rain coat, winter coat, 2 paper fans, paper wads (hail stones)*

*Set - up: Weatherman is in the middle of the stage with the NJs map not moving yet. The TV is propped up against the chair. The leader walks in, turns on the TV and sits down to listen. After the TV is turned on, the weatherman comes to life.*

**Weather:** *(Using the pointer)* Well folks, it looks like we're going to have a typical day of weather in New Jersey on this warm summer like day. All across the state there are sunny and clear skies. There is no chance of rain.

**Leader:** *(Turns off TV)* Good! We can go outside.

**Cub Scout 1:** *(Walks in fanning himself)* Boy what a great day to be outside. The sun sure feels good.

**Cub Scout 2:** *(Walks in wearing a rain coat)* It sure did cloud up fast. It's starting to rain.

**Cub Scout 3:** *(Walks in wearing a heavy coat)* A cold front just came in. It must be freezing out there.

**Cub Scout 4:** Hey did you guys see the hail coming down out there? *(Throws hailstones into the air).*

**Cub Scout 5:** *(Walks in wearing his uniform)* The sun feels good out there.

**Leader:** Yes, it sure is another day of typical New Jersey weather.

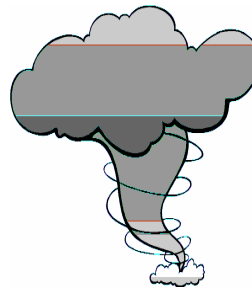

#### CRYING SKIT

Each boy comes in crying, each carrying a handkerchief progressing from small (tissue) to large (tablecloth to Super (bed sheet)). Someone asks why they are crying. They just cry louder and walk off stage. Last boy is asked why they are crying? And he replies "it's because we don't have a skit!"

#### WHERE IS YOUR HOME?

Divide the audience into two groups and have them respond to the following key words:

**Home:** "Home on the Range"

**United States:** "This Land is your Land"

Be it ever so humble, there's no place like HOME.  
No matter where in the UNITED STATES you may roam.  
You may travel all over the UNITED STATES,  
But your HOME state with you always rates.  
Some choose to roam while others stay,  
Always in their HOME state 'til their dying day.  
No matter in what part of the UNITED STATES your HOME state may be,  
There's one thing everyone says you see,  
And everybody I'm sure will remember that.  
HOME is where you hang your hat!

-Bay Area Council Pow Wow, 1994

# MY HOME STATE

## May 2004

### Games

#### **JERSEY HURRICANE DODGEBALL**

Play as Dodge ball rules: 2 teams on equal sides of playing area. 2 Dodgeballs in use. Players throw dodge balls to try and hit their opponents to get them out. If a ball hits a player before the ball hits the ground the hit player is out. If a player throws the ball and an opponent catches the ball before it hits the ground, the Thrower is out. Last team with a player still in is the winner. At least 1 referee is needed, having 2 is very helpful. Be sure throwing remains under control.

Hurricane Twist: Prior to each round of play, each team designates a boy from their team and tells only the referee(s). At any time the "Hurricane" is put out, either by being hit or by having a thrown ball caught, the whole team goes down. This makes for quick rounds and adds a twist to regular dodge ball.

#### **BIG J**

Have all players sit in a circle and then chose a person to be "it". The "it" is to leave so that "it" cannot see or hear. Choose one person to be Big J and he will act out short movements. Examples are clapping hands three times, stomping feet 4 times, etc. All other players must do what Big J does. Have "it" return to the group to figure out who is BIG J, you can give him up to three guesses if there's a large group.

### Run On/ Applause

#### **BUFFALO BONZO YELL** (For a 'corny' skit)

Bonzo  
Buffalo bonzo  
Buffalo buffalo bonzo  
Cuckoo, cuckoo, cuckoo !

#### **NEW JESREY OIL REFINERY APPLAUSE** - Crude, crude, crude...

#### **HOW WITH A SOUTH JERSEY ACCENT** - How, How, How, You'all!

#### **SOUTH JERSEY WATERMELON CHEER** – Do typical watermelon Cheer, end it with a "Y' ALL"

#### **JERSEY GRAND HOWL** –

Stamp feet three times,  
slap knees three times,  
whip hand around head three times, and yell "YO!!!!"

### **RIDDLES**

Q: Why did the Cowtown Rodeo Cowboy buy a dachshund?

A: Because all the other cowboys were saying, Get a-long little doggie!

How many Cub Scout Leaders does it take to change a light bulb? 12

- One to call a planning meeting,
- one to call everyone to find a date when everyone can get together,
- one to conduct the meeting,
- one to make an announcement about the planned light bulb changing,
- one to lead a song, one
- to write a skit about light bulbs,
- one to screw it in,
- two to do a run-on,
- one to lead a cheer for a job well done,
- one to bring refreshments,
- and one to buy patches for everyone who participated!

# MY HOME STATE

## May 2004

### Closings

#### NEW JERSEY IS DIFFERENT

- Cub # 1.** New Jersey is different in climate, different in the food produced, and offers different ways of life.
- Cub # 2.** The beauty of New Jersey captured in our meadows, beaches, rivers, hills and the glorious sunrises and sunsets.
- Cub # 3.** New Jersey is a part of the fifty United States of America, pledging their allegiance to our flag.
- Cub # 4.** Just like the state of New Jersey. There are differences in a Cub Scout den. Each boy has different abilities, different interests and different needs.
- Cub # 5.** But we are united in Cub Scouting to develop ourselves mentally, physically and morally.
- Cub # 6.** Just as Cub Scouting keeps us together and our packs & dens are parts of the whole Scouting program. Our country, the United States of America, all 50 states united and working together.
- Cub # 7.** We become better citizens as we learn and achieve together in Cub Scouting. Just as our country gets stronger by working together.
- Cub # 8.** Let us close by singing "America" in remembering our differences and our unity. (Or another patriotic song)

#### STATE PRIDE

New Jersey needs men with a concern for the common good -- men who have the understanding and insight to help solve her problems and those of the changing world around us. She needs citizens of integrity who value their great heritage and who are determined to pass on to others an enduring faith in the ideals and methods of our free society.

How does a boy come to know and to appreciate his heritage as a citizen of this state? How does his sense of responsibility and his concern for others unfold?

Begin with him when he is a Cub Scout as he promises with all the solemnity of an 8-year old "to do my duty to God and my country..." Watch the pride and loving care with which he handles the flag as he is taught to fold it. He may not fully understand all that it stands for, but someday he will... with help.

Observe him later as he stands tall, alert and proud in his khaki uniform as the flag is lowered at Scout camp. He is living everyday experiences as a good citizen and showing concern for the needs of others. He is growing and practicing the fundamentals of citizenship. All of this time he is under the friendly guidance and companionship of men and women who care about him.

Now he is grown tall.. in high school.. a Venturer or Explorer. He ponders the words of the Venturing Oath or Explorer Code. There is conviction in his voice as he says: "I will treasure my American heritage and will do all I can to preserve and enrich it."

And so this young American comes to manhood. He has grown through his Scouting experiences and through the influences of many men and women who have helped him. He has a job and a family and is making himself count in his community. He is a citizen of a great nation and state. He understands his heritage and cheerfully accepts his future obligations to all men. He has been a Scout. He is America's answer! He is New Jersey Pride!

# MY HOME STATE

## May 2004

### Closings

#### **COWTOWN COWBOY'S PHILOSOPHY**

*PERSONNEL: 5 Cub Scouts*

*SETTING: Boys up front*

**CUB #1:** We, the cowboys of today, are bound by our desire to live free.

**CUB #2:** We must, therefore, show respect for our fellow man,

**CUB #3:** Respect for his beliefs, Respect for his belongings, Respect for his privacy,  
Respect for the ground he walks on and the air he breathes.

**CUB #4:** In doing so, we show respect for ourselves.

**CUB #5:** And secure freedom for all.

#### **MY STATE**

*Have a Cub Scout read the narrative or pass out cards so the entire audience can read this pledge in unison or have 5 or 6 Cub Scouts repeat the lines from cards.*

**1ST CUB** -This is my state I will use my eyes to see the beauty of this land.

**2ND CUB** - I will use my ears to hear it's sounds.

**3RD CUB** - I will use my mind to think what I can do to make it more beautiful.

**4TH CUB** - I will use my hands to serve it and care for it.

**5TH CUB** - And with my heart, I will honor it.

#### **THREE IMPORTANT THINGS**

*Personnel: 4 Cubs or all may be read by a Leader or Cubmaster*

*Equipment: Cub Scout badge, handbook and a candle.*

**Cub # 1.** To the sailor, three things were essential - a compass, a sextant, and a flag to tell which way the wind blew.

**Cub # 2.** To Cub Scouts, these three things are important - (show items) a badge, a handbook, and a candle.

**Cub # 3.** The badge tells who you are and where you are going, the handbook tells how to get where you are going, and the candle is a symbol of the light of Scouting.

**Cub # 4.** It is a light that must be kept burning in the heart of every Scout.

Great Sauk Trail Council, 2001

# MY HOME STATE

## May 2004

### After the Meeting

#### WAGONS

Ingredients:

2 Celery stalks  
12 Toothpicks  
16 Carrot rounds  
1/2 c Peanut butter; cheese spread or ranch dressing  
20 Raisins

#### DIRECTIONS:

Cut celery stalks crosswise into two pieces each, about 3" long. Push toothpicks through sides of celery to form axles for four wheels. Fill celery wagon with peanut butter, cheese or dressing. Stick carrot rounds onto ends of toothpicks. Cover tips with raisins. Stick a toothpick into the end of the celery at a 45-degree angle to form wagon handle. Cover tip with raisin.

Just Kids Recipes: <http://www.justkidsrecipes.com/>

#### BARBECUED POPCORN

Ingredients:

6 tablespoons	Hot air-popped popcorn
1/3 cup	Margarine
3 tablespoons	Chili sauce
1 teaspoon	Onion powder
1 teaspoon	Chili powder
1/2 teaspoon	Salt
2 tablespoons	Grated Parmesan cheese

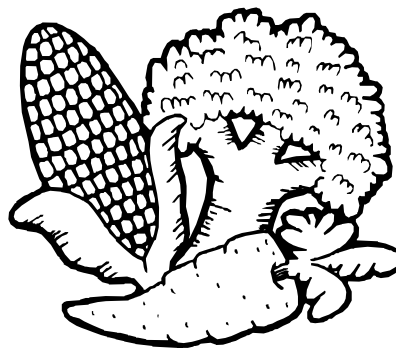

#### DIRECTIONS:

Place popcorn in large bowl. In small saucepan, melt margarine. Stir in chili sauce, onion and chili powder and salt. Pour chili mixture gradually over popcorn, tossing to mix well. Sprinkle with cheese and toss.

[www.hungrymonster.com](http://www.hungrymonster.com)

#### JERSEY CHEX MIX

Ingredients:

1 bag (3.5 ounces) Betty Crocker Pop Secret butter-flavored microwave popcorn  
8 cups Corn Chex cereal  
4 cups corn chips  
2 cups bite-size cheese crackers  
3 tablespoons margarine or butter, melted  
1 teaspoon chili powder  
1/3 cup grated Parmesan cheese  
1/4 cup Bac O's bacon-flavored bits or chips, if desired

#### DIRECTIONS:

1. Microwave popcorn as directed on bag.
2. Mix cereal, corn chips and crackers in 2-gallon resealable plastic food-storage bag. Shake popcorn into cereal mixture, being careful not to add unpopped kernels. Drizzle with margarine. Shake to coat mixture.
3. Add remaining ingredients. Shake gently to blend all ingredients.

# MY HOME STATE

## May 2004

### Outdoorsman

Webelos Scouting is the bridge between Cub Scouting and Boy Scouting. The Outdoorsman activity badge is the pier that supports that bridge. In this badge, the Webelos Scout will receive a preview of the fun he will have in Boy Scouting. The best way to work on this badge is by doing a Webelos overnight campout. This is not a full-fledged Scout campout, but a taste of what is to come when a boy joins a Scout troop. After a boy becomes a scout, he will become proficient at handling himself in the woods. As a Webelos scout, he is not expected to master these skills.

#### PERSONAL CAMPING GEAR

You can check off your needs on the five fingers of one hand: sleeping, eating, being clean, being prepared, extras.

##### SLEEPING

You want to sleep well. To do this you must be warm. For your first overnight camp, one to three blankets will do. Eventually you will want a sleeping bag. Before you buy one, ask the advice of those who have been camping. Buy the best sleeping bag you can afford. A bag filled with polyester fiberfill is good. Down is better. If the winters are severe, buy a winter weight bag. Open it up for summer use. You also want to be comfortable. Many campers use a shoulder to hip length polyurethane pad. Others like an air mattress. You place it on top of a plastic ground sheet. For nightwear bring pajamas.



##### EATING

You want to eat. Here you'll need an eating kit or separate knife, fork, and spoon. As well as a plate, cup, bowl, or a one man cook kit that includes all three.

##### BEING CLEAN

Bring soap in a plastic container, washcloth, toothbrush and toothpaste, comb and metal mirror, hand towel. Perhaps a plastic washbasin.

##### BEING PREPARED

Put in your pack a flashlight and a small individual supply of toilet paper wrapped in plastic. When you are not wearing them, outer clothing items go into your pack.

##### EXTRAS

You may want to take with you the Bible or prayer book of your faith. Plus a few favorite items you just can't do without. Just remember not electronic games; boom boxes are camping to enjoy nature not to disrupt it.



# MY HOME STATE

## May 2004

### Outdoorsman

#### KNIFE SAFETY

Facts every boy should know about knives:

- A dull knife doesn't work and is, in fact dangerous.
- Dull blades cut more fingers than sharp ones.
- A camper should always carry a small sharpening stone in his pocket along with his knife. The knife and stone are partners and belong together.
- A sharpening stone is called a whetstone. One measuring 3" by ¾" is large enough to use and small enough to carry easily.
- A whetstone using water is more practical in camp than one using oil.
- Whetstones are made to provide a grinding surface. Fine stones are for knives while coarse stones are for axes.

#### POCKET KNIFE SAFETY CIRCLE

A pocket knife safety circle is similar to an axe yard only smaller and on an individual level. To establish a safety circle, grasp a CLOSED pocket knife in your hand, extend your arm and with the closed knife straight in front of you, rotate body to either side while continuing to extend the closed knife arm. No one or thing should be within this imaginary circle you have created. Also check your overhead clearance, as this is part of your safety circle.

#### A TYPICAL KNIFE

A pocketknife should have a good stout blade at least 3 ½" long. Here is a close up view of a typical knife:

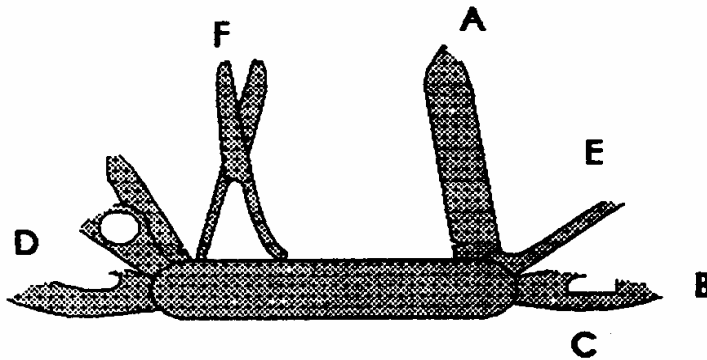

"A" is the main cutting blade.

"B" is the screwdriver.

"C" is the bottle opener.

"D" is the can opener.

"E" is a leather punch or awl.

"F" is a miniature scissor.

# MY HOME STATE

## May 2004

### Outdoorsman

#### EASY CARVING/ WHITTLING

An easy way to teach boys to carve is by carving soap into a simple design. Fresh soap, especially Ivory soap which is ideal, may be too soft and crumble. To prevent crumbling open the soap up and let in air for about 5 - 10 minutes. These could be done will you explain the rules of using a knife to the boys.

Whittle away from you (until you are an expert)! Be sure that nothing (your leg, another camper, branches etc) are in the way of the sweep of your knife.

Some types of knives

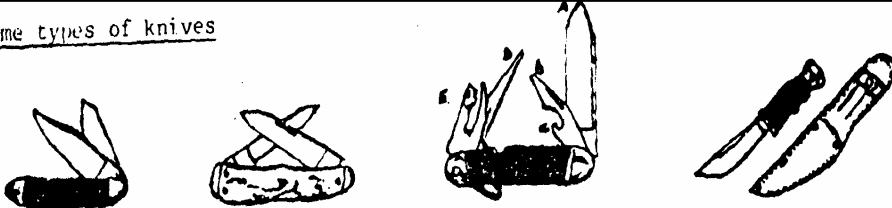

Two-bladed knife      Small-bladed knife for whittling      Four-bladed knife, with (a) blade, (b) screwdriver, (c) can opener, (f) ring for belt      Sheath knife (blade does not fold)

To open a jackknife:

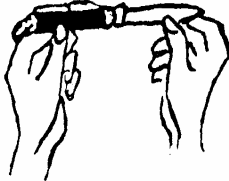
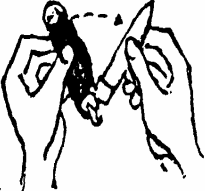

Hold knife in both hands, right thumbnail in slot. Pull blade out.      Keep hold with both hands until open.

To close:

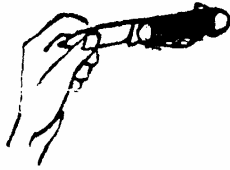

Reverse as at left holding blade until it is nearly closed, then letting it snap shut. Avoid closing with one hand.

To pass an open knife:

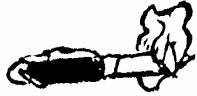

The person handing should hold knife by the blade, passing the handle to the other person. In this way the hander has control of the edge of the knife.

To clean and oil a knife:



Put a drop of machine oil on the hinge, and work blade a few times. Knife should open easily.      Clean blade with drop of oil and piece of paper, cloth or steel wool.      Don't stick in dirt or sand; may chip blade.

# MY HOME STATE

## May 2004

### Outdoorsman

#### KNOTS

Knots are a very important part of Scouting. Begin now to learn them. Its lots of fun and you can make a display of those you have done. Put them on a wooden board, name them and frame the board for a permanent display.

#### SQUARE KNOTS

This knot is used for joining two ends of a rope or string of approximately the same size or thickness. Use it to tie up a bundle or a bandage, to mend a shoestring, or to make a long rope from several small pieces.

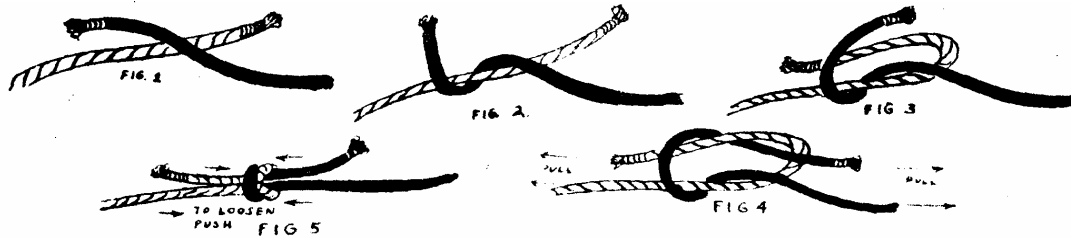

**SHEET BEND**  
When you have two ropes that are not of the same thickness, a square knot will not hold them, but if you

will give the square knot an extra twist, it will become a sheet bend, and will hold. This is one of several ways to make a sheet bend knot.

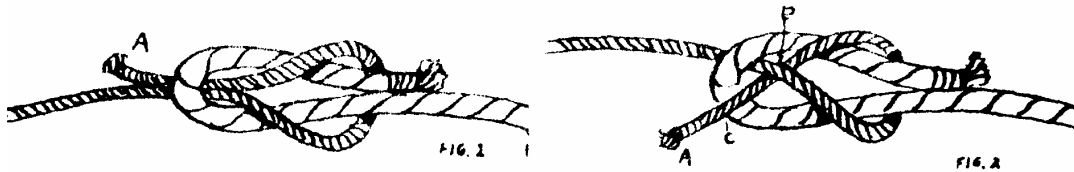

**BOWLINE**  
Use this when you want a loop in the end of a rope. This loop will not pull tight, but will

remain the size you made it. Use it to slip over a peg, or hook, or make the knot itself around a post or pole. It's sometimes called the rescue knot.

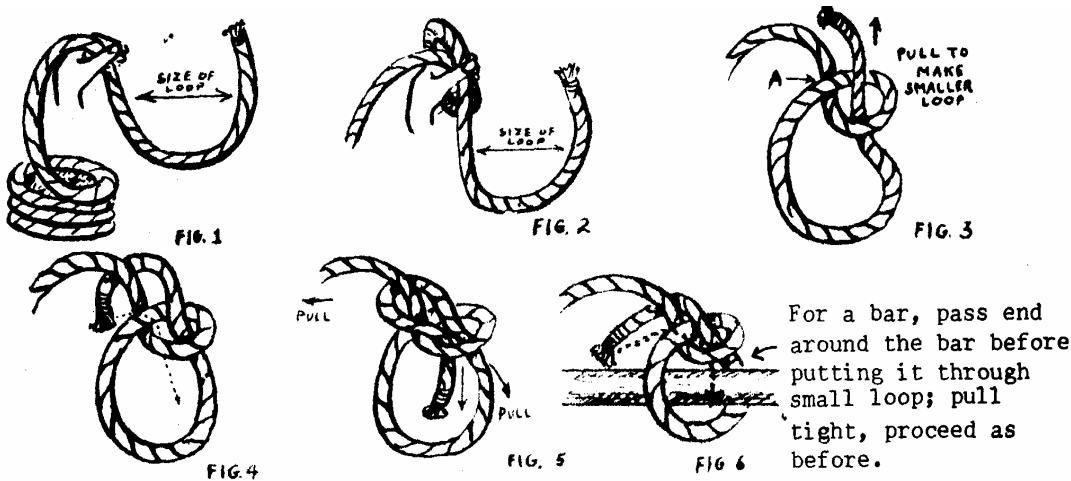

# MY HOME STATE

## May 2004

### Outdoorsman

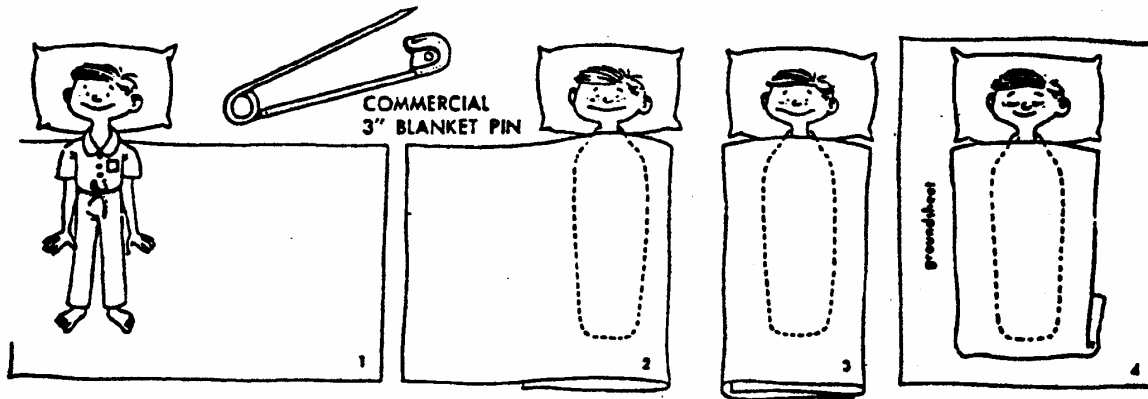

In summer, one blanket is often enough. Fold it so that you have two layers under you.

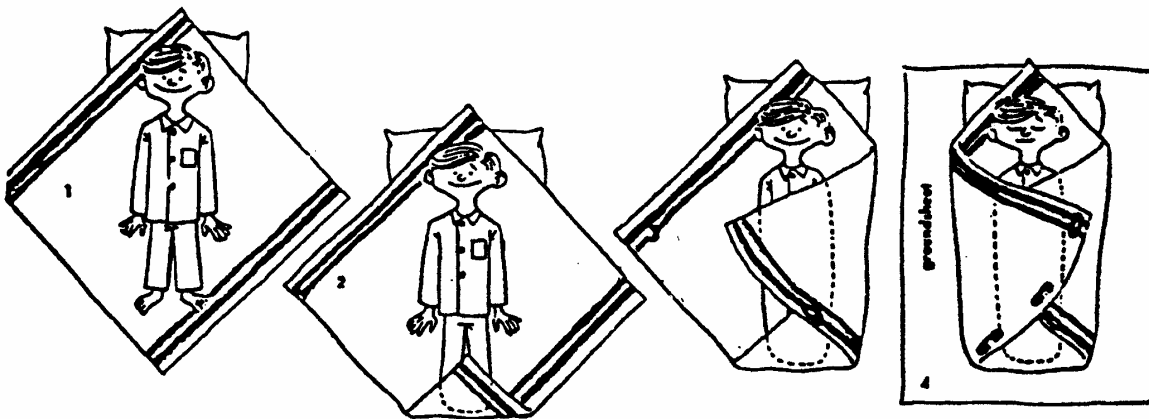

Fold a square blanket with one layer under you, two on top.

In cooler weather, you need at least two blankets. Fold first blanket with two layers under you. Then bring bottom up over your feet. Swing half of second blanket over you, and fold bottom under your legs.

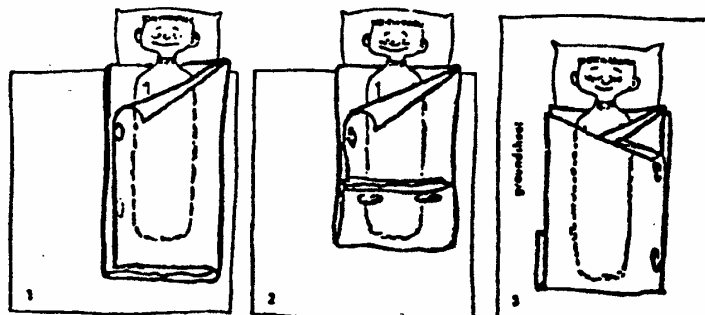

# MY HOME STATE

## May 2004

### Outdoorsman

#### MAKE A COMPASS

The face of the compass may be cut from  $\frac{1}{4}$ " plywood,  $\frac{1}{2}$ " plywood, or  $\frac{1}{2}$ " pine. The markings for the dial may then be applied with dark crayon, paint, or wood burning.

The needle for the compass consist of two  $1\frac{1}{2}$ " darning needles which have been magnetized by drawing a magnet over them in ONE DIRECTION ONLY from eye to point. The two darning needles are then inserted in opposite sides of a piece of cork  $\frac{1}{4}$ " high and  $\frac{1}{2}$ " in diameter, as illustrated.

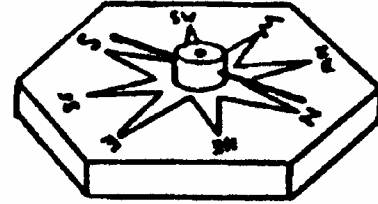

The needle assembly is suspend by means of a lower portion of a leather rivet, which is inserted in the bottom of the cork disk as illustrated in drawing. Leather rivets of this type can be purchased inexpensively at most hardware or variety stores. A small nail which will not bend when inserted in the rivet is placed in the center of the compass dial, and the head is clipped off so that the nail extends approximately  $\frac{3}{8}$ " above the wood surface. The protruding end of the nail should be rounded with a metal file to permit the needle assembly to swing freely.

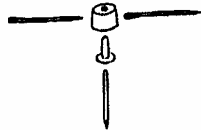
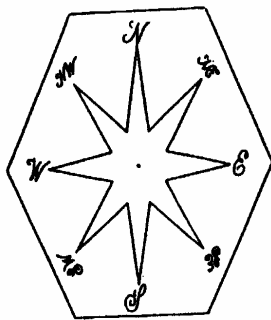

After the wood block has been given a finishing coat of shellac or clear varnish and has dried thoroughly, the needle may be mounted on the nail. The compass needle will point North. Then carefully turn the block until the needle is in line with the point on the compass dial marked "N".



#### SAFETY RULES FOR OUTDOOR ACTIVITIES

Always have as first aid kit handy. If possible, have an adult trained in first aid and CPR attend pack functions.

Remember that adequate leadership and supervision help prevent accidents. Encourage boys to pair up in buddies to be aware of each other's whereabouts at all times.

Have a plan for personal or natural emergencies (such as lighting storms, high winds etc.) which occur during an outdoor activity. Know where emergency care can be obtained quickly. If possible, check out the location in advance for hazards.

Avoid such dangers as buildings in disrepair or under construction, fire hazards, stinging insects, poison plants, too-rough sports or games for age and size of boys. Accidents can be prevented.

Select a well identified gathering place in the event the group is separated.

Always supervise when Cub Scouts are building fires and cooking. If the den is using a ground fire, clear a space 10 feet in diameter of all burnable materials. Stay away from low hanging branches. Use of chemical or liquid must be limited to adults.

# MY HOME STATE

May 2004

Outdoorsman

## COAT HANGER UTENSILS

Wire coat hangers can be bent and shaped into many helpful implements with wire-cutting pliers, as the sketch shows. Here illustrated are a fork, tongs, basting brush, skewer, rake, spatula, and ladle. The last two are lined with heavy-duty aluminum foil. When going family camping, make these tools and see how practical they are.

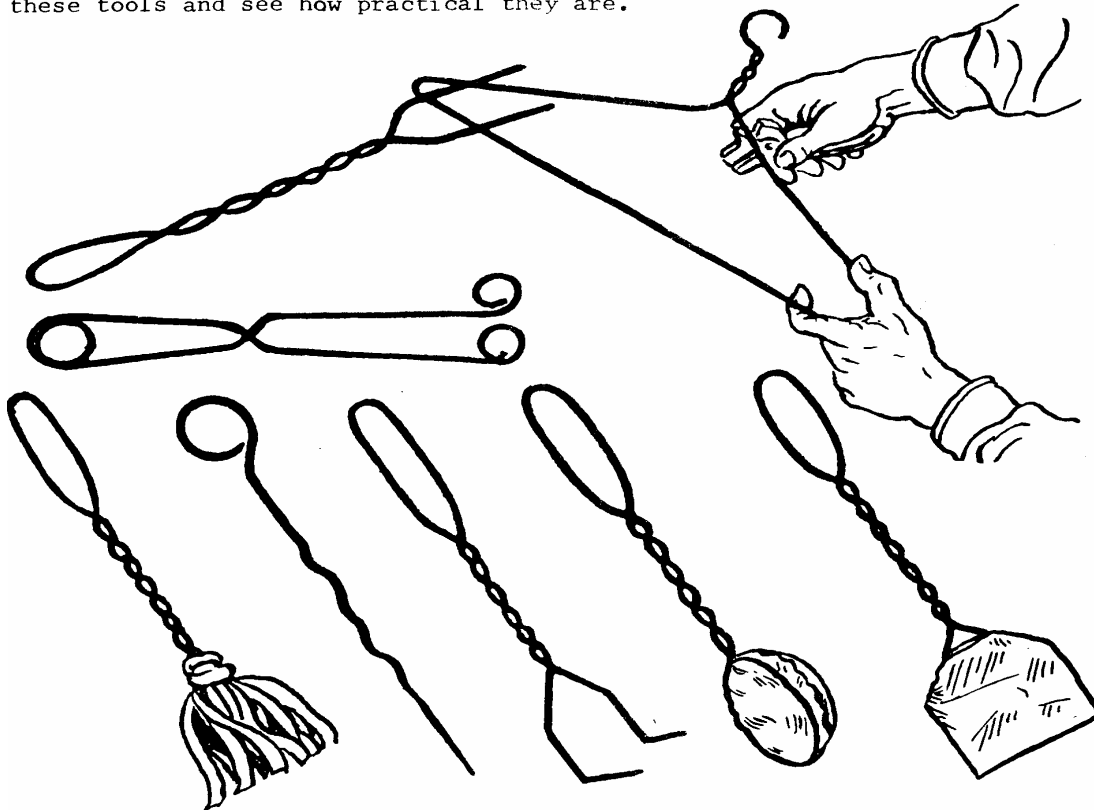

## HANDWASHING

If running tap water is not available a simple hand washing unit can be made from a plastic jug and a wooden dowel or twig. Make a small hole near the bottom of the jug. Use the twig or dowel to plug up the hole once you've filled the jug with water (a golf tee works very well). Place a bar of biodegradable soap in an old pantyhose leg and tie this to the handle of the jug. Now hang one of these hand-washing units near the kitchen. For better water flow, remove the cap from the jug.

# MY HOME STATE

## May 2004

### Handyman

#### **POUND, POUND, POUND THAT NAIL**

*Tune: Row, Row, Row Your Boat*

Pound, pound, pound your nail  
Pound it right on through!  
If you miss and pound your thumb,  
Then it will turn bright blue.

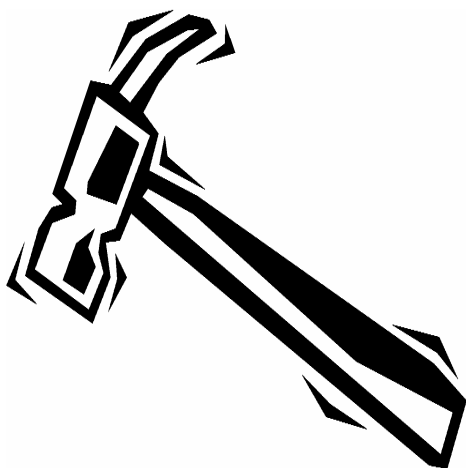

#### **TOOLBOX SONG**

*Tune: I'm a Little Teapot*

I'm a pair of pliers just because  
Here is my handle here are my jaws

#### **CHORUS:**

Keep me in your toolbox bright and new  
Take me out and I'll work for you.

I'm a coping saw that's strung too tight  
Pull me then push me to use me right.  
Chorus

I'm a big strong hammer, a mighty tool.  
Hit the nails only, that's the rule.  
Chorus

I'm a happy C-clamp, tell you what I do,  
I eat board sandwiches filled with glue.  
Chorus

I'm a handy wood plane, give me a try.  
I can help you out if your door's too high  
Chorus

#### **HANDYMAN HINTS**

- ◆ Place Dad's old sock over shoes when painting.
- ◆ For plugged drains, mix 1 cup salt and 1 cup baking soda and pour down drain. Follow with kettle of boiling water.
- ◆ To seal a tiny leak in a plastic garden hose, touch the hole lightly with the tip of a Phillips head screwdriver that has been heated over a flame. The plastic will melt enough to plug the hole.
- ◆ Weeding is less tedious with the right toll. A claw hammer will pull out weeds by the clump. An apple corer is also an excellent weeder- it doesn't disturb the roots of adjacent plants

# MY HOME STATE

## May 2004

### Handyman

#### TOOL CADDY

A neat carrier for garden tools is an old golf bag. It's got pockets for tools, even a place to hang a towel, and you can whisk it along on its built-in wheels. Just roll it in the garage until you need it again.

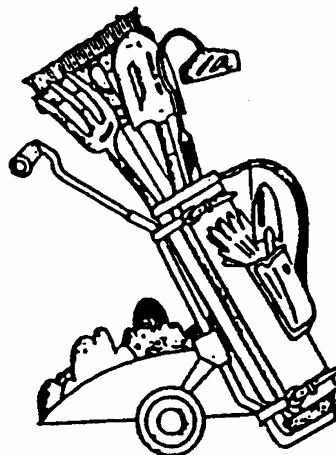

#### GARDEN TOOL FIRST AID

Garden tools stow quickly and stay dry in a pail filled with sand. Mix sand with a little oil to keep the tools from rusting and to keep their edges sharp. If garden tools have rusted, clean them with a cork dipped in scouring cleaner.



#### STICK WITH WICKETS

Thread your garden hose through croquet wickets to keep it from running over your flowers.

#### IN THE BAG

An easy yard clean-up carrier is an old TV tray table. Remove the tray, then hang a plastic garbage bag on the open framework between the legs.

#### OFF THE WALL

Prune shrubbery and trees to keep them from touching the house. The leaves retain moisture, which causes the paint to blister and peel.

#### FLOWER BOX SPLATTER CONTROL

Keep rain from splattering dirt out of

your window box onto your window by placing a layer of gravel on top. The gravel will also keep the soil from drying out.

#### UNDER COVER

Paint the under side of your metal garbage can lid with rustproof paint so condensation from wet garbage won't damage the paint on the lid.

#### STORAGE BOX

Paint a design on a discarded mailbox. Use it to store barbecue supplies, paper cups, and plastic utensils

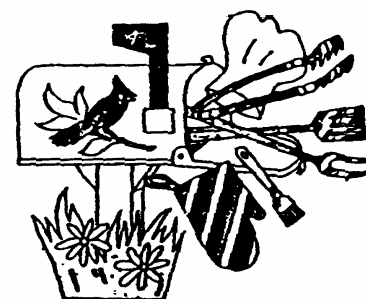



# MY HOME STATE

## May 2004

Handyman

### LET THERE BE LIGHT \*

A MAZE BY PETER MAY

When it comes to getting this lamp plugged in, we're completely in the dark. Our current quandary is owed to the tangle of extension cords on the living room floor. Only one

succession of hookups will lead from the wall outlet on the left to the lamp at upper right. Can you help us make the right connections?

ANSWER, PAGE 66

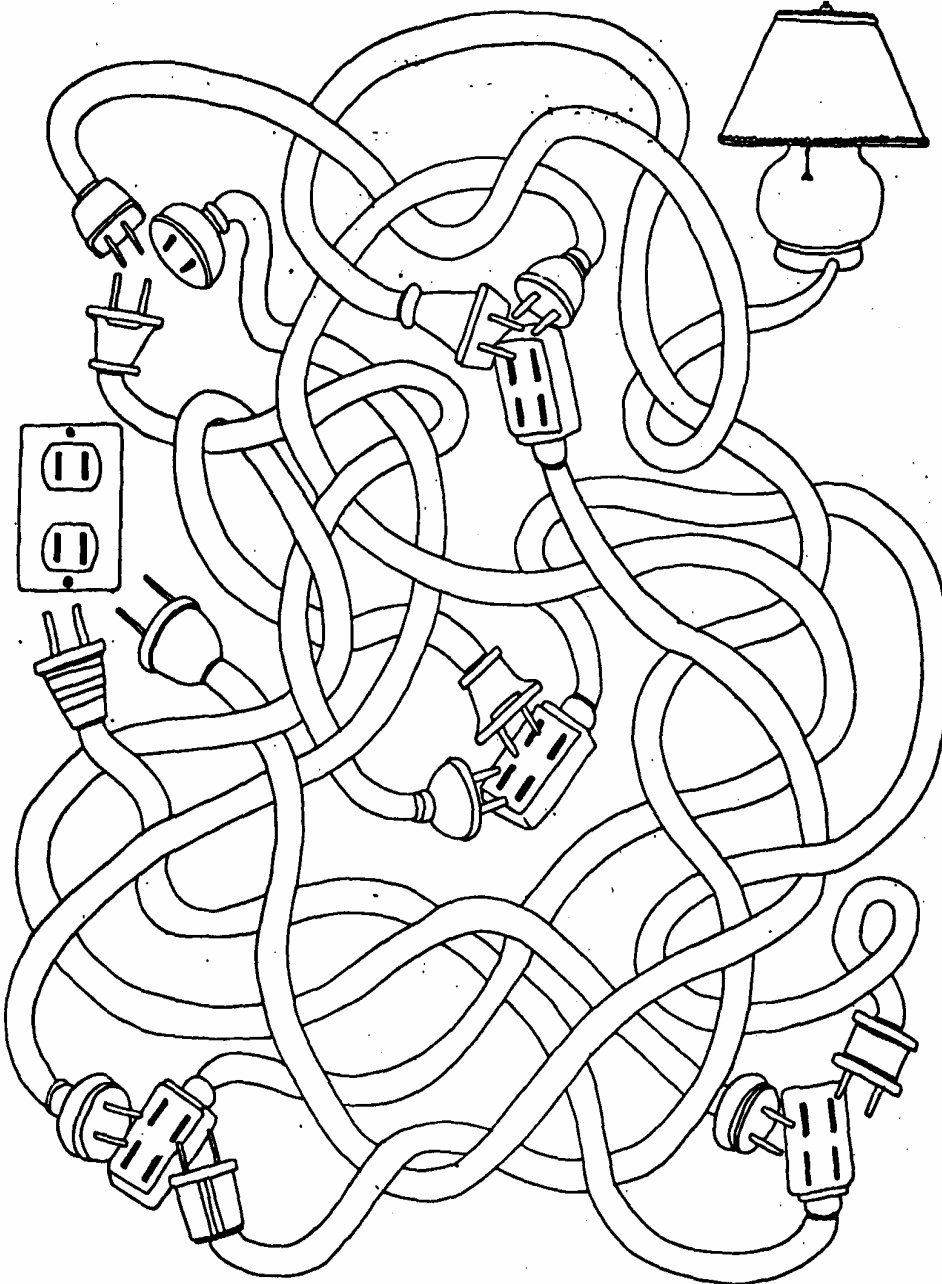

# MY HOME STATE

## May 2004

### Tigers - Picnic Fun/ Fun Outdoors

#### Family Activity

1. Take a bike ride. (Be certain to practice bicycle safety.)
2. Play catch or Frisbee.
3. Go roller-skating or roller-blading. (Always wear protective gear.)
4. Visit the zoo.
5. Plant a flower and/or vegetable garden.
6. Visit a nearby playground or park.
7. Have a barbecue or picnic at a park.
8. If you cannot get to the park, have a picnic in your backyard.
9. Did your picnic get rained out? Do not despair. Have an indoor picnic, complete with blankets, paper plates, cups, etc.
10. Go fishing.
11. Take a paddle boat ride.
12. Go swimming in a creek or pond (Practice water safety, of course!)
13. Take a blanket and several books outside and read under the shade of a tree.
14. Make homemade ice cream.
15. Wash the car together. This can be great fun on a hot day!
16. Camp out in the backyard.

#### Frisbee Golf.

This is a great game that can be set up in a backyard, in a park or around a neighborhood. The basic idea is that you have laundry baskets or some other sort of receptacle, some flags or a way to see the receptacle and a few Frisbees. Just like regular golf, you try to land your Frisbee in the "hole" in as few shots as possible.

#### Stories

Make up a great story and tell it outside. The longer the better. Sit in a circle and take turns adding one paragraph to the story. You'll be surprised at how it all ends up.

#### Make homemade ice cream.

You can get a freezer for about \$20. Pick up a bag of ice, rock salt, a gallon of low-fat milk, and a can of non-fat Eagle Brand. Let your child mix the Eagle Brand, a cup of sugar, 1/8 t salt, and tablespoon of vanilla extract with about two cups of milk. Stir until the sugar has dissolved, then pour into the freezer. Add more milk to the fill line, load it up with ice and rock salt, and let it run for about 40 minutes.

#### Watermelon and Sprinkler.

Watermelons are so sticky and messy in the house. Instead, just cut a whole watermelon into enough pieces for your family and their friends then send them outside and turn on the sprinkler. You don't even have to watch it, just let them loose to get as sticky and wet as they want.

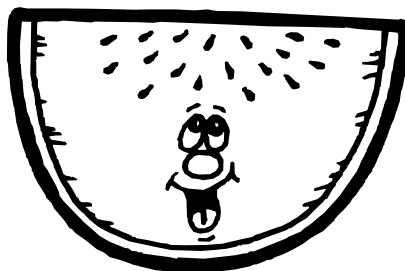

# MY HOME STATE

## May 2004

### Tigers - Picnic Fun/ Fun Outdoors

#### Den Activity

You can't go wrong with sports activities. Put up a hoop for basketball or suggest the boys get active with skipping, tag, racing, baseball, soccer or swimming. Always emphasize the fun and not the competition.

Go fly a kite! (If you don't have one, make one!)

Study the shapes of passing clouds, then use cotton balls and glue on paper to recreate the images they saw.

#### Bubble solution

Start by mixing together 1/4 cup of dishwashing liquid, 2 cups of water, and 1 teaspoon of sugar. Pour the mixture into a shallow container.

#### Bubble Mania

Have a bubble blowing frenzy using a variety of unusual bubble blowing tools! Plastic funnels, six pack soda rings, plastic cups with holes punched through the bottom.

#### Bubble Art

Now take the bubble mix, pour some into a cup and add a few drops of food coloring. Blow rainbow bubbles into the air, and try to catch them with a white sheet of paper! After the paper dries, use markers or crayons to finish your masterpiece! Mail Just 4 Me

#### Pet Rocks

Find smooth, flat or round rocks. Be sure to clean off any dirt or sand and dry completely before starting. Paint with acrylic paints. Decorate faces by using google eyes, yarn for hair, markers, glitter, and any other tidbits you like.

#### Go See It Outing

Music in the park concert

See additional Ideas on Theme pages "Home State" den activities

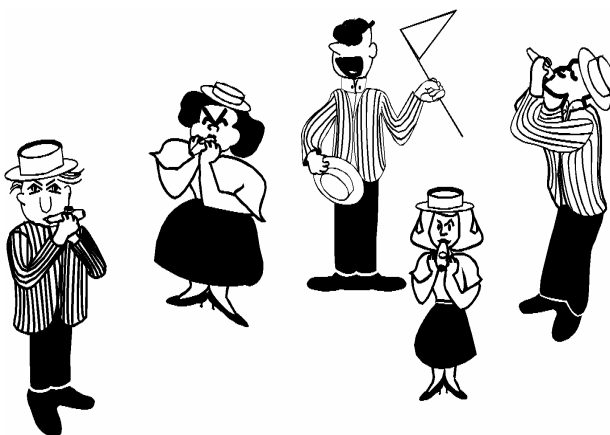

# MY HOME STATE

## May 2004

### Cubmaster Corner - Year Round Program

#### **THE BASIS OF A SUCCESSFUL PACK**

Program planning is a simple but critical part of your pack's success. Throughout the process remember your goal is to deliver a high quality program to each boy and his family. It should be fun, exciting and focused on the purposes of Cub Scouting. Setting an annual program plan provides direction and sense of satisfaction and a feeling of accomplishment in a job well done. Planning also makes the best possible use of your valuable volunteer time.

#### **Planning Steps:**

One of the most important responsibilities of the pack committee is to keep the pack operating with a first-rate, year-round program. The quality of the program will depend largely on the pack committee giving the Cubmaster, the Cub Scout den leaders and Webelos den leaders the help they need.

Cub Scout program planning includes four steps, dependent upon one another, which usually guarantee a strong pack program.

The steps are:

Annual Pack Program Planning Conference

Monthly Pack Leader's Meetings

Monthly Den Leader Meetings

Monthly meetings of each den leader with the den chief

#### **Steps to having a great Annual Program Plan**

**SET A DATE TO MEET** - Set a date in August with the committee, including the Den Leaders and Webelos Leaders.

**CHECK MEETING DATES** - Before this time check with your chartering organization and school calendar to find available dates for pack meetings. They should be at the same time and date each month.

**REVIEW LAST YEAR'S PROGRAM** - Which activities worked and which did not? Decide what activities and special meetings you would like to do again. Also determine whether or not your budget was adequate for them.

**SET NEW MEETING DATES** - Review the available pack meeting dates with the pack committee and set dates for the coming year. Write pack meeting dates in your council calendar (extra copies are available through the Service Center for your committee members and den leaders). Be careful to avoid holidays and school breaks.

**SET COUNCIL AND DISTRICT DATES** - Review the council and district calendar and mark dates on your program schedule for district and council activities: Webelos Woods, Pinewood Derby, training sessions, and important meetings like roundtable.

**SET SPECIAL PACK DATES** - Set the dates for special activities your pack will be doing during the year and put them in your program calendar. These may include:

Pack Fundraiser (Product Sale)

Blue and Gold Banquet

Pinewood Derby

Friends of Scouting

Summertime Activities

Webelos and Tiger Graduation

# MY HOME STATE

## May 2004

### Cubmaster Corner - Year Round Program

Beginning June 1, 2003, adults giving leadership to a pack campout **MUST** complete the Basic Adult Leader Outdoor Orientation (BALOO). Please check council calendar for upcoming BALOO training sessions. (This is not required for council-run programs i.e.: Akela.)

**SCHEDULE YOUR MONTHLY COMMITTEE MEETING** - Select dates for and schedule monthly meetings of your committee to meet and plan out the next month's activities and meetings (i.e. in September you should be planning for October). You should have a committee meeting every month.

**SELECT A MONTHLY THEME** - Select monthly themes from the Program Helps or choose your own. Write them in your annual calendar so everyone knows what the month's theme is for both Cubs and Webelos.

**SET A BUDGET** - Based on the meetings and activities you have planned for the year, number of boys who are likely to advance, and the number of youth and adult members of the pack, figure out what your approximate yearly expenses will be. You will need to plan enough fund raising activities to cover these expenses in the following order of priorities:  
The Budget Planning Worksheet will help you calculate and plan your annual expenses and income to create a budget.

**DISTRIBUTE THE PLAN** - Cub Scouts and their families will better participate in meetings and activities if they have a copy of the calendar. Every family should receive a copy of the annual calendar so they can plan accordingly.

These are the basic steps your committee will need to follow to have a complete annual program plan and calendar. This calendar will help insure that everyone in the pack knows exactly what is happening from month to month during the year. More important, it will help you plan in advance and avoid being caught off guard by rapidly approaching deadlines.

Remember that September brings \*\*\* Join Scouting Night and the start of a full year of activities. When you go to Join Scouting Night, if you have a well thought-out plan and distribute it to your members, new and old, you will find it is easier to recruit not only boys but also adult leaders.

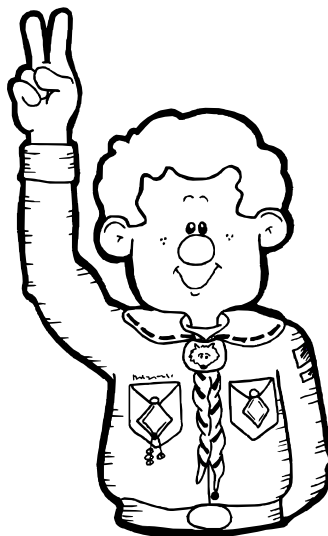

# CUB ROCK

## June 2004



Welcome to Cub Rock! The boys can learn about prehistoric times by creating table settings, toys, clothing, school supplies, vehicles, etc. These ideas would be great for use in a skit and these skits could be shared at a prehistoric pack meeting. What a good month for geology and learning about the dinosaurs. By the end of the month, all the boys will be looking at rocks in a whole different way. With cooperation and team building in mind, this might be a good month for a prehistoric scavenger hunt. What fossils can you find?

Cub Scout Theme .....	03
Webelos – Traveler .....	19
Webelos – Artist .....	22
Tigers - Snack Time/ Fresh Baking .....	26
Cubmaster Corner - Den and Pack Newsletters.....	30

# CUB ROCK

## June 2004

Many will be shocked to find  
When the day of judgement nears  
That there's a special place in heaven  
Set aside for volunteers.  
Furnished with big recliners,  
Satin couches and footstools,  
Where there's no committee chairman,  
No group leaders or car pools.  
No forms to fill out, signs to make,  
No bazaar or bake sale,  
Not a thing to staple, patch or tape  
And nothing to fold or mail.  
Telephone lists will be outlawed,  
But a finger snap will bring  
Cool drinks and gourmet dinners  
And treats fit for a king.  
You ask, "Who'll serve these privileged few  
And work for all they're worth?"  
Why, all those who reaped the benefits  
And not once volunteered on Earth.



### **Inscription on a plaque at the Institute of Rehabilitative Medicine - Author Unknown**

I asked God for strength, that I might achieve.  
I was made weak, that I might learn to humbly obey.  
I asked for health, that I might do greater things.  
I was given infirmity that I might do better things.  
I asked for riches that I might be happy.  
I was given poverty that I might be wise.  
I asked for power that I might have the praise of persons.  
I was given weakness that I might feel the need of God.  
I asked for all things, that I might enjoy life.  
I was given life, that I might enjoy all things.  
I got nothing that I asked for--but everything I had hoped for.  
Almost despite myself, my unspoken prayers were answered.  
I, among all people, am most richly blessed.

# CUB ROCK

## June 2004

### Gathering Activities

#### MATCH THE DINOSAURS

Draw a line to the picture and name that match.



A.

1. CARCHARODONTOSAURUS



B.

2. DRYPTOSAURUS-HADROSAURUS



C.

3. EUOPLOCEPHALUS



D.

4. GORGOSAURUS



E.

5. SINORNITHOSAURUS



F.

6. TYRANNOSAURUS



G.

7. VEIOCIRAPTORINE-PSITTACOSAUR



H.

8. EOLAMBIA



I.

9. GIGANOTOSAURUS



J.

10. SHUNOSAURUS

ANSWERS: 1-a, 2-f, 3-j, 4-h, 5-b, 6-c, 7-I, 8-d, 9-e, 10-g



# CUB ROCK

## June 2004

### Openings

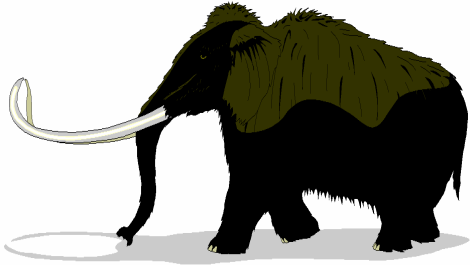

#### DINOSAURS

*Have each boy hold up a picture of the dinosaur as they say their parts. Parts can be written on the back of their picture.*

Cub 1: An ANKYLOSAURUS could swing it's massive club tail with great force if attacked.

Cub 2: Scientist believe that IGUANODON used it's spiked thumbs as weapons.

Cub 3: OVIRAPTOR may have been small, but it's powerful jaw and parrot like beak could crush bones!

Cub 4: STEGOSAURUS used it's heavy tail, armed with pairs of spikes to defend itself.

Cub 5: STENONYCHOSAURUS may have run at speeds of 50 miles per hour!

Cub 6: TYRANNOSAURUS used its razor sharp teeth to both defend itself and eat.

ALL: Tonight as CUBS ROCK and dinosaurs roar join us in the Pledge of Allegiance.

#### CUB ROCK

*Have each boy hold up a letter as they say their part.*

**C** Dinosaurs lived millions of years ago.

**U** The word dinosaur comes from two Greek words that mean "terrible lizard."

**B** Dinosaurs vary in size, appearance and habits in many ways

**R** Scientist believe that the continents once formed a single land mass surrounded by an enormous sea.

**O** Dinosaurs were both meat and plant eaters.

**C** Dinosaurs used different forms of defense against their enemies

**K** About 63 million years ago, dinosaurs died out suddenly.

**ALL:** Welcome to our Pack meeting tonight as we "Rock and Roar."

# CUB ROCK

## June 2004

### Den Activities

#### FIELD TRIP IDEAS

- ◆ Take the children to a museum with a fossil collection.
- ◆ Invite a local paleontologist to visit your class and show a fossil collection.

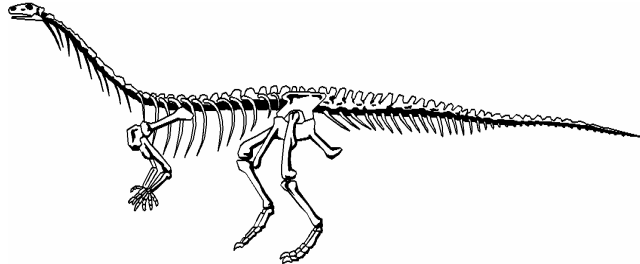

#### CAVE DRAWINGS

On a wall, hang a roll of paper at least six feet long (but preferably up to 10 feet long). Have the boys draw a picture of their favorite dinosaur on it. When they're done, ask them to name their new prehistoric friend (leaders can write the names in) and sign their name next to their drawing. In advance of the pack meeting, you and your boys might want to draw in some background scenery, such as boulders, palm trees, ferns, ponds and hills, to help get the mural started. The final product will make a nice mural for the wall or backdrop for the stage.

#### INTRODUCING DIFFERENT DINOSAURS

Go to your local library or bookstore to locate the book "Tyrannosaurus Was a Beast" written by Jack Prelutsky. The book contains various poems about types of dinosaurs. Each poem describes the dinosaurs and their characteristics in rhyme. The poems could be used to talk about different dinosaurs and what they could and could not do.

Let the boys make up their own dinosaurs and list what its characteristics are. How tall, what color, etc. let them share their new dinosaurs with the group.

#### PACK MEETING IDEAS

Make dinosaur footprints, cut from brown paper have them leading the families into the pack meeting location.

Lots of large green plants and giant rocks will add to the decor.

Hang dinosaur posters on the walls for a little more authenticity.

Top the tables with a black vinyl cloth and small, bushy, plants, small rocks and plastic or paper dinosaurs the boys have made.

No plasticware at this meeting! Instead use Frisbees for plates and let them eat with their hands. Provide each family with an oversize cloth or paper napkin cut from dinosaur fabric. If you desire paper, purchase a dinosaur tablecloth at your local party store and cut into napkins. If you want to serve some finger food try cutting dinosaur shape sandwiches (deep cookie cutters works well) and heat up some dinosaur shaped chicken nuggets. Don't forget to mix up some red punch for volcanic lava juice.

# CUB ROCK

## June 2004

### Den Activities

#### DINOSAUR WEBSITES

##### The Dinosauricon

(<http://www.dinosauricon.com>)

This site is the best place to start for information about specific dinosaurs or dinosaur families.

##### ZoomDinosaurs.com

(<http://www.enchantedlearning.com/subjects/dinosaurs>)

This site contains lots of dinosaur information, including a useful Dinosaur Dictionary.

##### Dinosaur Illustrations

(<http://web.syr.edu/~dbgoldma/pictures.html>)

The dinosaur illustrations at this site include just about every type you can think of, from *Acrocantosaur* to *Xiphactinus*.

##### DinoDon.com

(<http://www.dinodon.com>)

Dinosaur expert Don Lessem provides lots of dinosaur resources, including stories, facts, art, and additional links.

##### Dinosaurs

(<http://www.letsfindout.com/subjects/browse?dinosaurs>)

This dinosaur site includes individual pages about many different types of dinosaurs.

##### Discovering Dinosaurs

(<http://dinosaurs.eb.com/dinosaurs/index2.html>)

Learn how scientists' theories about dinosaurs have changed through the years.

##### The Age of the Dinosaurs

(<http://www.cotf.edu/ete/modules/msese/dinosaurflr/meet.html>)

The Staircase of Time at this site is an excellent resource for discovering when dinosaurs lived.

##### Walking With Dinosaurs

(<http://www.bbc.co.uk/dinosaurs>)

This site is full of sights, sounds, and information about dinosaurs and the times they lived in.

##### Dinorama

(<http://www.nationalgeographic.com/dinorama>)

Discover a variety of dinosaur information from past issues of *National Geographic*.

##### Walking With Dinosaurs

(<http://dsc.discovery.com/stories/dinos/dinos.html>)

Explore how dinosaurs looked, moved, sounded, and behaved.

##### Arthur's Colour Dinosaur Clipart

(<http://www.geocities.com/SoHo/Village/4040/colour.htm>)

This site offers large images of a variety of dinosaurs.

##### Dinosaur Clip Art

(<http://www.designs4free.com/clipart3/dinosaurs/ulthm.htm>)

You'll find three pages of dinosaur images at this site.

# CUB ROCK

## June 2004

### Crafts

#### FOSSIL PRINTS

Developed by Reach Out!

*What is a fossil?*

*Can I make a fossil print?*

What You Need (per person)

Stone Dough Mix

1/2 cup of salt

1 cup flour

1/2 cup of brewed coffee (cold)

1 cup of used coffee grounds

Measuring cups

Mixing spoon

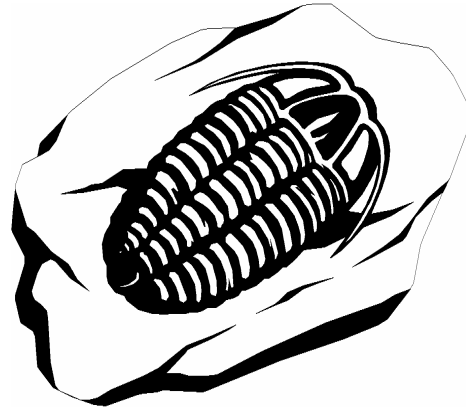

FOSSILS to imprint

Twigs

Leaves (stiff bay leaves work well)

Dead, hard shelled bugs like roly-polys

Seashells

Chicken bones

Plastic dinosaur to get skin texture or footprints

Mixing Bowl

#### DIRECTIONS

1. Measure salt, flour, coffee, and grounds; add each to bowl; and stir together until well mixed.
2. Turn this dough out onto a large sheet of waxed paper and knead it until smooth.
3. Break off a piece large enough for the imprint you want to make, roll it into a ball, and use the heel of your hand to flatten it out.
4. Press the object you wish to make a fossil imprint of firmly into the dough. You can use more than one object if you like. Carefully remove the objects to leave the prints behind. Let your fake stone dry overnight and you have an imitation fossil!

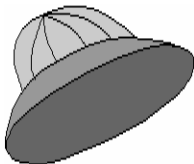

#### PITH HELMETS

Purchase these helmets very inexpensively in party stores. Let the boys personalize their pith helmets with brightly colored dinosaur stickers. Let them wear them at pack meeting.

# CUB ROCK

## June 2004

### Crafts

#### DINOSAUR FEET

These feet are fun to play racing games with so make a couple of sets  
[www.cubscoutpack391.org](http://www.cubscoutpack391.org)

*What you will need:*

*Shoe box size boxes*

*Paint*

*Fun Foam*

*Glue gun*

*Knife (adult supervision)*

*Newspaper*

*Duck tape*

#### DIRECTIONS:

1. Cut a small hole in one end of each box just big enough for a boy's foot to fit in.
2. Tape the box closed with strong tape. Stuff the inside front and sides of the box with newspaper leaving just enough room for a boy's foot to fit inside.
3. Spray paint the boxes a dinosaur color and let then dry.
4. Cut out 2" claws from fun foam and glue to the front top of the box.

#### ROCK CREATURES

Clean some smooth, flat stones by washing them in detergent. Then decorate them with acrylic paints. Use contact cement or white glue to join the rocks. They will adhere better if you saturate a small piece of cotton and place it between rough-edged rocks. After gluing, run a collar of glue cement around joints to make a lasting bond. Challenge the Scouts to invent a new creature and name him/her!

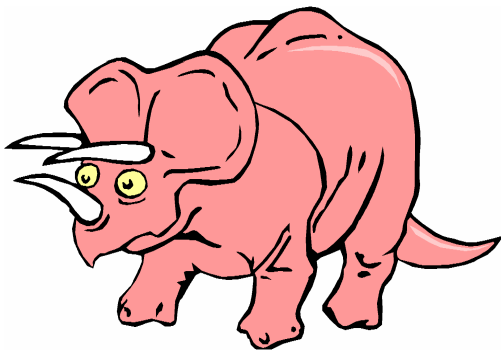

#### MODELING DINOSAURS

The boys can use clay to make their dinosaurs for display at Pack meeting. Make name tags with their creations name on it and the paleontologist (boys name) who discovered it.

#### DINOSAUR MOBILE

*Need:*

*2 Wire hangers*

*String*

*Paper dinosaur shapes or pictures of dinosaurs with hole punched to string*

#### Directions:

Take to wire hangers and form an X. Tie together with string.  
Take different pictures and string them then tie to hanger.

# CUB ROCK

## June 2004

### Songs

#### LONG AGO

*Tune: Three Blind Mice*

Dinosaurs, dinosaurs,  
Roam the land.  
Long ago!  
You were here, when the land was new.  
You ate all your veggies, meat and grew.  
You were the king and all the others knew.  
Dinosaurs, dinosaurs.

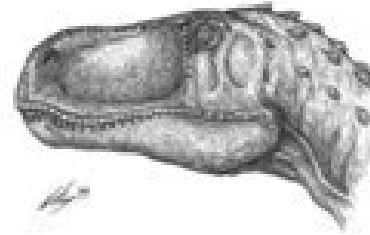

#### DINOSAURS

*Tune: "Oh Christmas Tree"*

Oh Dinosaurs, Oh Dinosaurs  
How I wish I could hear you roar.  
Did you eat meat or plants galore?  
I really would like to know.  
Why you left this planet so long ago  
Oh Dinosaurs, Oh dinosaurs  
Being extinct means you are no more!

#### WHO AM I

*Tune: "I'm a Little Teapot"*

I'm a Brontosaurus that really neat!  
I eat plants, but I don't eat meat.  
Know as Thunder Lizard because when I walked  
The earth shooked, rattled and rocked!

#### CHORUS

Dinosaurs, Dinosaurs, that we have all know.  
Some are large, some very small.  
Fossils gave us the clues that is true  
Because we came after you!

Tyrannosaurus Rex is his name.  
Meanest of the dinosaurs, that's a shame.  
He makes the others run and hide!  
He wants to eat them that no lie!

Chorus



# CUB ROCK

## June 2004

### Skits

Great skit for leader to perform for the boys. Add sound effects and light to give them a feel of being in a prehistoric time.

#### THE FIRST SCOUT

York Adams Council

*Props: Only one-a "skin" with a charcoal drawing of the Arrow of Light. (Use a crumpled paper bag for the skin and black marker to draw the AOL.) The actors need to be attired appropriately. The interviewer should look the part of an old Scouter (the more like B-P the better). The Scout being interviewed should look as Neanderthal as possible (skins for clothing; a club; heavy, unkempt hair and beard, etc.).*



**Narrator:** Good evening ladies, gentlemen, all Scouts and Scouters. Tonight we join our investigative reporter, BP, in an exclusive interview with the first-ever Scout. Let's join them now.

*(Stage curtains open to Scouter and Caveman standing together.)*

**BP:** So, you are called the oldest Scout in the world. Just how old are you?

**CM:** Well, counting all the time before there were calendars, I figure I'm somewhere around 5000 years old-give or take a century.

**BP:** Wow! Five thousand years old! And to what do you contribute your longevity?

**CM:** Why the skills and abilities I gained through Scouting, of course! It's what's kept me going all these years.

**BP:** Scouting, eh? So what was Scouting like in your day?

**CM:** Well, to begin with, I'd have to say it was a little primitive. Things like we had to use little round pebbles for dues, vines for knot tying. Those kinds of primitive limits.

**BP:** I imagine so. What about badges?

**CM:** Yeah, we had badgers, but the dinosaurs were more of a bother than badgers.

**BP:** No, not badgers, badges! Did you earn badges?

**CM:** Oh, I'm sorry. You know what they say, "Hearing is the second thing to go." Can't remember what the first thing is. What did you ask me?

**BP:** Badges! Did-you-have-to-earn-badges?

**CM:** Oh yes! We earned all kinds of badges. Fire starting was one of them. Really needed to know how to start fires. Kept the cave warm, you know. And then there was stalking. We had to learn the skills of stalking. Why we had to be able to stalk just about any animal there was-any worth eating, at least.

**BP:** What about other skills? Did you have to learn about Home Repairs or Gardening?

# CUB ROCK

## June 2004

### Skits

#### THE FIRST SCOUT (Continued)

- CM:** Well, sorta. Home Repairs was a must. Did you know I came up with one of the words we use to describe parts of a window? Happened one cold December day. (Well, we would have called it December if we had a name for it or a calendar even.) The wind and the wolves were howling and the snow was just pouring through the front hole in the cave wall. My mom told my dad that if something weren't done about it, he wouldn't be allowed to go camping the following weekend. So my dad told me it was my job. He said I could earn my Home Repairs badge if I could fix it. So I just took the oil-skin sash from around my bear skin robe and draped it in front of the hole. It stopped the snow and we could still get light through it. And from that day on, they've called the covering over a hole in a home a "window sash."
- BP:** Yes, I see. And did you have a Gardening badge?
- CM:** Almost. We called it Gathering, but it evolved into Gardening when we got a little sloppy with it. We used to have to go out gathering seeds to eat. You know-grains and berries and such. Well one time there was a hole in my sack and some of the seeds dropped out just outside the cave. Next thing we knew, the seeds had turned into plants and those plants had seeds. We just kept the plants right outside and we had all the seeds we needed from then on.
- BP:** In today's Scouting program, there are different ranks the boys earn, like Bobcat, Wolf, and Bear. Did you have anything like that.
- CM:** Of course, we had all them. I earned my Bobcat when I was first in Scouts. Had to go out with the leader and find a Bobcat in the mountains. When I finally spotted one and got really close to it, I held up my hand like this (holds up Cub Scout sign) to let my leader know I'd spotted one. I figured it would draw his attention so he'd listen and not make a lot of noise. Then, after I'd caught it and we went back to the cave, I was telling them how I'd reached out with two fingers really straight and GRABBED the Bobcat around the leg with my other fingers. Everyone thought that was a really good way to grab something. Here, let me show you. (Shows BP how to do the Cub Scout handshake!)
- BP:** Something really familiar sounding about those things. Did you earn any other badges?
- CM:** Well there was the Wolf badge. We had to do all sorts of things to earn that one. Like learning how to use and properly care for a blunt rock and a sharp rock. We also had to clean up rocks around the cave. And learn the difference between our tribe's cave logo and others' logos. And for the Bear badge-another one we earned-we had to listen and learn about old, prehistoric tales about cavemen like Volcano Vort (who used to float down the lava rivers) and T-Rex Rex (a tale about some Neanderthal who used to ride dinosaurs). Also we almost had to learn how to ride a bike, except we didn't have a wheel so we didn't have tires so we didn't have a bike so we didn't have to do that.
- BP:** Again, these things you did sound like things I've heard our Cub Scouts have had to do. Are there any other special badges that you earned or learned about?
- CM:** Well, there were many other badges, but the one I remember most had to be the Arrow of Light. You probably don't know about that one, so let me show you how we would draw it on the cave walls. We got this when we had proven that we were ready to go onto bigger and more challenging things.
- BP:** So there you have it. Seems not too much has changed since the first Scout. I guess that's what they mean when they say "The more things change, the more they stay the same!"



# CUB ROCK

## June 2004

### Skits

#### THE WAY DINOSAURS MOVED

*Narrator reads as the other boys act out the motions.*

Dinosaurs of Long Ago

The dinosaurs lived long ago,  
and walked like this, and that. (Slow, heavy walk  
movement.)

Some were large (Stretch hands upwards.)  
and some were small. (Crouch down.)

Some liked water (Swimming motions.)  
and some just walked on land. (Stomp feet.)

Some had wings, that flapped and flapped. (Flap arms.)

Some had long necks, that stretched and stretched. (Hand on neck stretching upward.)

The meanest, rudest one of all was ferocious Tyrannosaurus Rex.

(Feet apart, hands clawlike, scowl and growl.)

These were the dinosaurs of long ago.

Goodness gracious, where did they go?

(Boys run off stage)

*Author Unknown*

*Modified by Maria E. Torres*

*Re-modified by Terri Cody*



#### FRIENDLY DINOSAUR

*Boys can be dressed as different dinosaurs or wear a sign with a picture of the dinosaur and it's name around their neck. As narrator read the boys act out what is being said.*

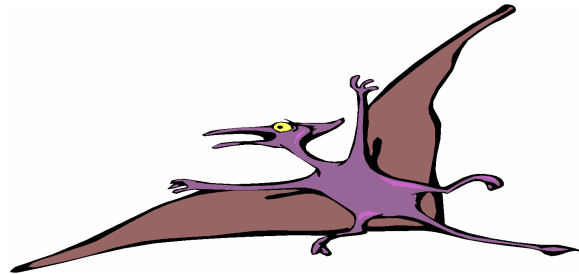

One Friendly Dinosaur

One friendly dinosaur wanted to play peek-a-boo.

He found another, then there were two.

Two friendly dinosaurs looked behind a tree.

They found another, then there were three.

Three friendly dinosaurs went to find some more.

They found another, and then there were four.

Four friendly dinosaurs in the water did dive.

They found another, and then there were five.

Five friendly dinosaurs played in the sun.

They all ran to hide; now there are none.

# CUB ROCK

## June 2004

### Games

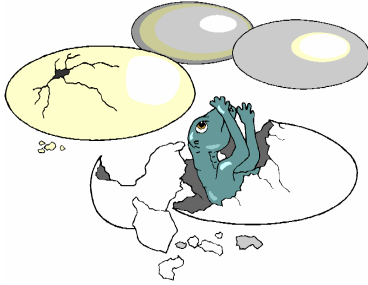

#### **DINOSAUR EGG HUNT**

Paleontologists know that even giant dinosaurs started out life in fragile shells. Send your boy's searching around your yard or house looking for "dinosaur eggs." You can use the plastic eyes and fill with dinosaur shaped candies and boxed fruit treats.

#### **DINOSAUR CHARADES**

Write out the names of different dinosaurs on individual pieces of paper. Fold them and place them in a hat/bowl/anything. Each boy picks a piece of paper and then acts out the characteristics of his particular dinosaur. For younger children that aren't yet reading, you could provide pictures instead.

[http://ny.essortment.com/dinosaursbirthd\\_rvhv.htm](http://ny.essortment.com/dinosaursbirthd_rvhv.htm)

#### **HATCHING DINOSAUR EGG**

Similar to hot potato, all the boys stand in a circle. One boy is handed either a water balloon or a real egg. The music starts and the balloon/egg (a.k.a. dinosaur egg) is passed to the next boy. No one wants to be left with the dinosaur egg, because that boy is out of the game. Continue playing until there is only one boy left.

#### **DINOSAUR DIG**

This energy-burning bone hunt is best set up in a dry sandbox, but a sheet of plastic covered with sand and set in an easily cleaned spot will work as well. Before the meeting, bury twenty to thirty dog-bone biscuits of various sizes, as well as one plastic dinosaur skeleton. Let a couple of bones peek out from the surface to give the boys a head start. Hand out a small plastic pail and shovel to each boy and give them five minutes to dig up as many dinosaur parts as possible (they must use the shovel; no hands allowed!). The boy who finds the most bones gets a prize; the one who finds the dinosaur gets to keep it.

#### **DINOSAUR NEST**

Hide a nice big watermelon outside in the bushes somewhere, and send the boys out to hunt for the dinosaur's nest and bring back its egg. When they find it, cut it up and share it with the entire group

#### **DINOSAUR MATCH**

Where you tape names of dinosaurs on the back of the boys, two of each name, and each boy has to find out who they are and find their match by asking questions. Be sure and use dinosaur names that the boys are familiar with.

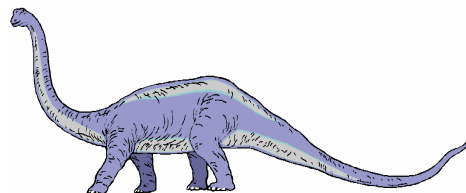

# CUB ROCK

## June 2004

### Advancement Ceremonies

#### THE CAVEMANS FIRE (outdoor ceremony)



The cave men settled down at night and usually had a fire for cooking and for warmth. It takes several ingredients to make a campfire.

To start, you have to find some small sticks or twigs.

(Have bobcat candidates bring in some twigs or sticks and place on the ground) Discuss their accomplishments and present badges. (Set sticks on fire)

The next ingredient is to add kindling to get the fire going. (Have Wolf candidates put kindling on the fire). Discuss their accomplishments.

The next step is to add the fuel to the fire. We do this by adding wood. (Have bear candidates bring in wood and place on fire). Discuss their accomplishments.

The Webelos scout adds to his knowledge and Scouting experience by completing activities. The fire will not burn unless more wood is added. (Have Webelos place more wood on the fire). Discuss their accomplishments.

With fire now burning take an arrow and discuss the elements to earn the arrow of light. (Call candidates forward) This arrow and the light from the fire represents the highest honor a Cub Scout can achieve. The Arrow (hold up arrows) of Light. (Point to fire). Discuss accomplishments.

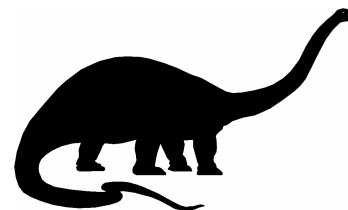

#### THE TROPHY SKIN

*EQUIPMENT: Trophy skin, badges and arrow points. Pin badges and arrow points on trophy stands in ascending order. Wolf badges and arrow points on bottom. Arrow of Light awards on top.*

*To make Trophy skin: Cut piece of leather, cardboard or suede clothe in the shape of bearskin. Use sticks for the frame.*

**CUBMASTER:** This month our Cub Scouts have been working hard to advance in rank. Tonight, we will honor those who have achieved a new rank or earned arrow points. We're proud of them and their parents, too. Because, you know, a Cub Scout can't advance without the help of his parents. Our Webelos Scouts don't pass their badges to their parents, but they need their encouragement. So we're going to ask them to take part in our ceremony too. (Cubmaster then calls forward boys who have earned Wolf rank, with their parents) Each boy takes his Wolf badge from the trophy shin and parent pins it on his uniform while Cubmaster briefly explains how it was earned by completing 12 achievements. Follow the same procedure for the Bear and arrow points.) Webelos Den Leader then uses the same ceremony for Activity badges, Webelos badge, and the Arrow of Light.

**CUBMASTER:** Advancement is just a part of the fun of Cub Scouting. But it's an important part, because through advancement our boys learn new skills that will help them when they join a Scout troop and throughout their whole lives. Let's give a grand howl for our den mates who advanced tonight.

# CUB ROCK

## June 2004

### Run On/ Applause



#### RIDDLE

Why did the dinosaur cross the road? Because chickens weren't invented.

#### RUN ON

Cub #1: I see green, yellow, and blue spots  
in front of my eyes.

Cub #2: Have you seen a doctor?

Cub #1: No, just green, yellow, and blue  
spots.

Cub #1: (Singing) Soap, soap, soap

Cub #2: What are you doing?

Cub #1: Oh, just singing a few bars.

Cub #1: There's been a robbery in my  
backyard!

Cub #2: What happened?

Cub #1: Two clothespins held up a pair of  
pants.

Cub #1: Scientists believe that cavemen  
made the first music by banging  
stones together.

Cub #2: Gee, I guess that was the first rock  
music!

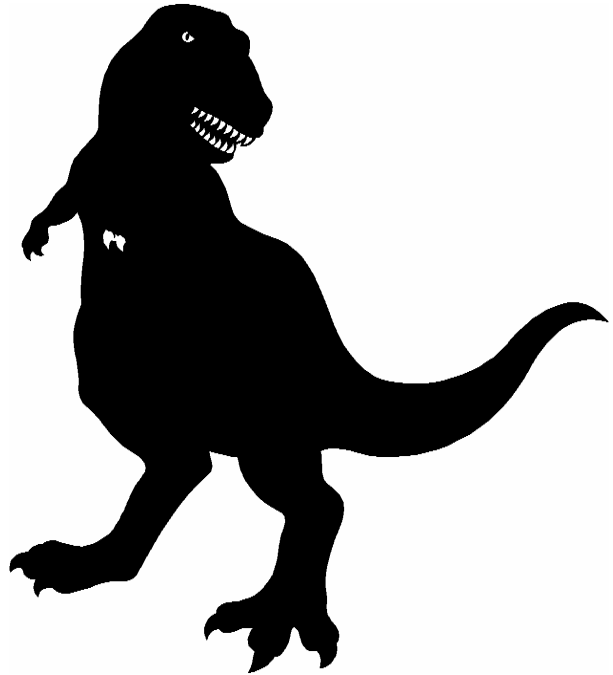

# CUB ROCK

## June 2004

### Closing

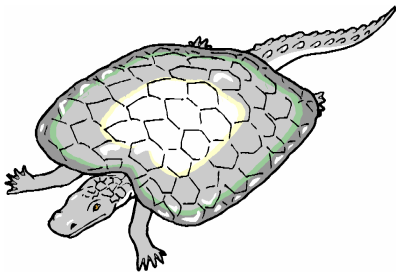

#### **DOUBLE CIRCLE**

*PERSONNEL: Entire pack - Cub Scouts, parents, and visitors.*

*EQUIPMENT: United States flag, four spotlights or four large flashlights*

**ARRANGEMENT:** Have all present stand in a double circle, with Cub Scouts and other boys on the inside, and parents and visitors on outside. Focus spotlights or flashlights on the flag held in center of circle. Sing "God Bless America."

#### **WHICH ONE OF THESE ARE YOU - Cubmaster minute**

One of the most important things about people is what they eat. Every culture in the world has different kinds of food. To some people, raw fish is a delicacy. Others love to snack on snails. Still other people consume insects such as locusts and ants, and they enjoy every bite. Many in America eat beef, pork, and chicken, but there are millions of people in different parts of the world that do not eat meat at all. Different kinds of people put different kinds of food into their mouths, and the food we eat is important. But there is something that is even more important: it is what comes out of our mouths. Jesus Christ, one of the world's greatest teachers, once said, "it is not what goes into the mouth that makes a person unclean, but what comes out of the mouth; that's what makes a person unclean." (Matthew 15:11) What did Jesus mean? Simply this: what you eat with your mouth does not define your character, but what you say with your mouth does. What kind of messages are you sending out to other people? Does your language reflect the Cub Scout ideals of duty to God, duty to country and service to others? Are you courteous and kind with your words, or are you hurtful and rude? Our words can make us a help to someone else, or they can make us a hindrance. Which one of these are you?

#### **CLOSING CEREMONY FOR PARENTS**

*Personnel: 7 Cubs*

*Equipment: Game, Jackknife, book or pet, fishing pole*

1st Cub: "What shall you give to one small boy? A glamorous game (holds up game), a tinsel toy,"

2nd Cub: "A knife (holds up jackknife), a puzzle pack, a train that runs on curving tracks?"

3rd Cub: "A picture book (holds up book), a real live pet... No, there's plenty of time for such things yet."

4th Cub: "Give him a day of his very own - Just one small boy and his parent alone."

5th Cub: "A walk in the woods, a romp in the park, a fishing trip (holds up fishing pole) from dawn to dark."

6th Cub: "Give the gift that only you can - Your companionship, your wisdom and your love" (Points to audience as he say his line)

7th Cub: "Games are outgrown, and toys decoy - But he'll never forget if you give him a day."



# CUB ROCK

## June 2004

### After the Meeting

#### DINOSAUR SNACKS

There are lots of snacks that are in dino shapes cookies, jelly candy, animal cookies, etc. Or bake your own with dino cutouts.

#### DINOSAUR DELIGHTS

Need:

1/4C dirt (cocoa)

1/2C swamp water (milk with green food coloring)

2C crushed bones (sugar)

1/2C fat (butter)

2C dead grass (uncooked oatmeal)

1/2C squashed bugs (peanut butter)

Mix cocoa & milk. Add sugar and butter. Boil about 3 min. Add peanut butter and oatmeal and stir until melted. Remove from heat and stir until mixture begins to thicken, Drop by tablespoonful onto waxed paper cool, eat and enjoy.

#### DINOSAUR LUNCH

Dino legs (chicken legs)

Tree tops (broccoli)

quick sand (apple sauce)

Dino bread (Dinosaur shaped crackers)



#### SWAMPY SALAD

Need:

2 cups applesauce

1/2 cup peanuts

1/2 cup raisins

1/2 cup miniature marshmallows

Mix everything together in a medium bowl pretend you are a Brachiosaurus hiding in a swamp from a fierce meat-eating dinosaur.

#### DINO EGGS

Need:

Hard boiled eggs

Small bowl

3 cups

cool water

1 envelope unsweetened kool aid mix ( choose bright colors)

Clear plastic wrap

- 1) Gently tap the hard boiled eggs ( make sure there not hot) all over till the shells cracked. Do not take the shells off the eggs.
- 2) In a small bowl stir together water and kool aid mix. Add cracked eggs to the colored water.
- 3) Cover the small bowl with plastic wrap. Place it in the refrigerator. Leave the eggs in bowl for about 2 days. remove the eggs and throw away the colored water. Peel the shells off the eggs. Your Dino eggs are now ready to eat.

# CUB ROCK

## June 2004

### After the Meeting

#### FOSSIL PRINTS

Need:

Round crackers

1 tub soft cream cheese

Gummy Dinosaurs

Goldfish crackers

Celery leaves



Help each boy spread the cream cheese onto a cracker with a knife. Press any of the other items into the cheese then lift up to see the "fossil". All but the celery leaves are to be eaten.

#### DINOSAURS & VOLCANOES

An edible idea is to put a cup of chocolate pudding in a plastic bowl. Place a sugar cone upside down in the middle of the pudding. Dribble white icing that has been colored with red, yellow, or orange food coloring over the pointed end of the cone. Bury gummy dinosaurs in the chocolate pudding. We talked about volcanoes and how they often bury plant and/or animal life when they erupt. There you have it - the sugar cone is an erupting volcano. These were a big hit with the kids and easy to do.

#### BAGEL STEGOSAURUS

Makes 4

Need- bagel, cream cheese, or peanut butter, or jam, sliced strawberries, very thin long slices of carrot.

1. Slice a bagel in half, then cut the pieces in half again so you have 4 half circles. (Adult)
2. Give each boy a bagel part, to be the stegosaurus's body. Place on the plates so it is like an upside down U.
3. Use plastic knives to spread peanut butter, or cream cheese, or jam all over the bagel.
4. Let boys arrange the strawberry slices on top of the stegosaurus's back to look like his plates.
5. Arrange a carrot slice on one side to be the neck.
6. Arrange a strawberry on the carrot to be the head. Eat!

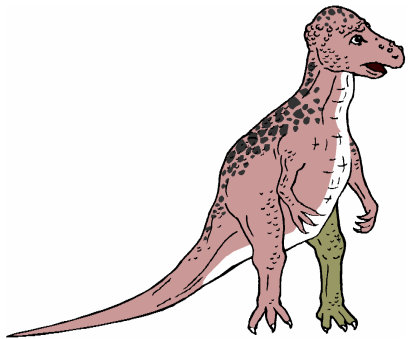

#### COOKIE PALEONTOLOGIST

Submitted by: Kristi Mushat

Your boys can act as paleontologists. Give each boy on chocolate chip cookie, a hard one will work better. Also give each boy a popsicle stick to scrape out the "bones", the chocolate chips, like if a paleontologist were scraping bones out of the dirt. They can eat the cookie when they are done.

# CUB ROCK

## June 2004

### Traveler

#### GEOGRAPHY

Players are seated in a circle. First player names a geographical term- city, river, country, mountain, etc. Second person must give a place: River-Mississippi, Mountain-Everest, etc. Continue around the circle. The same word is not to be given twice. This could also be made into a relay race.



#### PLOTTING YOUR ROUTE

Give each boy a state map. Tell them you are leaving this city and going to \_\_\_\_\_ (another city in the state), and have each boy plot the route. The object is to be the first to plot the most direct route to that point. After several attempts, have them plot an entire trip, with several designated stopovers.



#### I PACK MY SUITCASE

One boy starts the game by saying, "I'm going on a trip. I packed my suitcase, and I put in a \_\_\_\_\_." The next player says the same thing but first must repeat what the first boy said and then add his item. Each boy in turn repeats the entire thing and adds an item. If a boy is not able to repeat all previous items correctly he is out of the game. The game ends when only one boy is left.

#### ALPHABET EYE-SPY

This is another touring game. When you reach the town or city limits start looking for objects. Start with the letters of the town name. Boys call them out. If the town is Lincoln, a boy might say, "Eye-spy a library for the first letter or a Ice rink for the second letter and so on. This can be played at a den meeting with objects that can be seen in the room.

#### TRAVELER QUIZ

You are on a ship five miles from an entrance to the Panama Canal and sailing due west towards it. In what body of water is your ship?---*Pacific*  
Flying due south from Detroit, what foreign country do you reach first?---*Canada*  
Which is nearer Miami, California or Brazil?---*California*  
Which is farther north, Venice or Halifax?---*Venice*  
Which is farther south, Venice or Vladivostok?---*Vladivostok*  
Which is larger, Japan or Great Britain?---*Japan*  
What four states in the U.S.A. touch at one point?---*Arizona, Colorado, New Mexico, and Utah*  
Does a great circle from Tokyo to the Panama Canal pass east or west of San Francisco?--  
-*East*

Let the boy try to answer these questions by using a world map.



# CUB ROCK

## June 2004

### Traveler

#### GUIDE TO EMERGENCY ACTION

##### **AUTO ACCIDENT**

If you are the first to arrive on the scene of an accident, park well away from the accident, ahead of the scene. Send or call for emergency services as needed. Render aid to injured to the extent that you are qualified. Don't move an injured person unless there is threat of further danger or injury due to their location. If possible, on busy thoroughfares, wrecked vehicles should be moved well off the road (after witnesses have carefully noted the locations of the cars in relation to one another). Ignitions should be turned off. One warning flare should be placed 10 feet back from the vehicle, a second one 300 feet back, and a third 100 feet ahead of the scene. **WARNING!** Do not light flares near spilled gasoline. If you are involved in the accident, write down the license number of the other car and the name and address of the driver. Get names and addresses of witnesses.

##### **CAR FIRES**

Most car fires are the results of a short circuit in the car's electrical system. Don't waste time trying to disconnect the battery. If you don't have a fire extinguisher, rip loose any burning wires with a jack handle and smother with a blanket or coat. Don't grab wires with your bare hands! If the fire burns out of control and endangers the gas tank, get away from the car immediately!

##### **HEADLIGHT FAILURE**

Brake as quickly as possible without throwing the car into a skid or causing a collision. Ease onto the shoulder well away from traffic. Set out warning flares. Call for help.

##### **CAR SUBMERSION**

Don't panic. On average, cars with windows and doors closed will float 3 to 5 minutes – enough time for you to escape if you keep your head. **UNDO YOUR SEATBELT FIRST.** If the car does sink before you can get out, an air bubble will form in the section of the passenger compartment closest to the surface. Wait until enough water has seeped into the car to equalize the pressure so that the window or door can be opened relatively easily without an overwhelming rush of water. Take a breath from the trapped air and swim for the surface.



# CUB ROCK

## June 2004

Traveler

# MAKING AN ASTROLABE

During his historic voyage, Christopher Columbus used simple instruments and his knowledge of the sun and stars to guide him. Follow these steps and you'll be able to determine latitude the same way.

### Directions

1. Cut out a cardboard semicircle with the measurements shown.

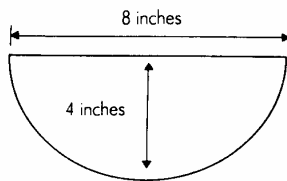

2. With a protractor as your guide, turn your semicircle into a protractor by writing the numbers and degree markings shown. Don't write within the top 1/2 inch of the cardboard.

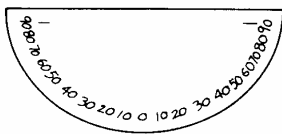

3. Tie one end of your string around the center of your straw.

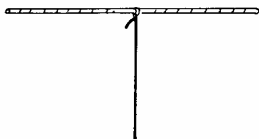

4. Tie the weight to the other end of the string.

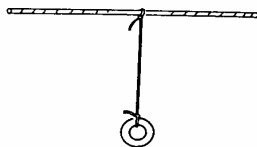

5. Glue your straw just above the 90° marks.

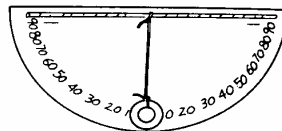

6. On a clear night, take your astrolabe outside. Face north (get your bearings from the western part of the sky where the sun sets). Look for the two stars in the Big Dipper farthest from the handle. They point to Polaris, the last star in the Little Dipper's handle.



\*  
Polaris

7. Sight Polaris through one end of the straw. Without moving the straw, pinch the end of the string against the protractor.

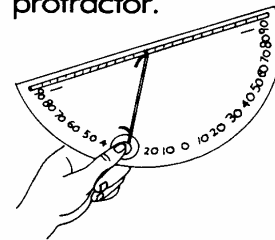

8. Return to a lighted area to read the degrees indicated on your astrolabe. Use an atlas to determine the approximate latitude of your location. What do you notice about your astrolabe reading and your latitude as shown in the atlas?

**Materials:** cardboard, a soda straw, a 12-inch piece of string, a weight (heavy paper clip, or metal washer), protractor, glue, scissors, fine-point marker, atlas

# CUB ROCK

## June 2004

### Artist

#### ZOO

Divide the group into two teams. Have a sheet of wrapping paper for each team. Teams line up in relay fashion. On signal, the first boy on each team runs to a leader who gives him the name of an animal. The boy goes to the paper and draws his subject. When the team recognizes what he has drawn, the next boy in line tells the leader. If correct, he is given another animal and begins to draw. First team to have everyone draw a subject is the winner.

#### DEN IDEAS

- ◆ Let the boys use their imaginations for the Artist Activity badge, and then visit the museum at the end of the month to see what famous artists have done with the same materials.
- ◆ Cut ten blocks of wood for each boy, plus a larger block of wood for the base. “Three-quarter inch square molding” from a lumberyard is excellent for this purpose. Have the boys make sculptures by gluing blocks together—stacked, angled corner to surface, edge to edge, whatever. Then go to the Dallas Museum of Fine Arts and see what David Smith, a famous American sculptor, did with ten blocks of stainless steel and a welding torch.
- ◆ Let each boy make a large tissue paper collage, using the colors of his choice. The base for the collage can be 4 or 9 sheets of typing paper masked taped together. Then go to the DMFA and see what Henri Matisse, a famous French artist did with this same idea.
- ◆ Have boys make mobiles, following instructions on page 42 of Webelos Scout Book. Then go to DMFA and see what Alexander Calder, originator of the mobile did.
- ◆ Have boys make free form sculpture of clay. Then go to DMFA and see Henry Moore’s interpretation of Woman, Jacques Lipchitz’s bather, Constantin Brancusi’s Egg, Barbara Hepworth’s Contrapuntal Forms, and Jean Arp’s Sculpture Classique, to name only a few.
- ◆ An “original painting” need not be an uninspired photographic reproduction of reality. At the DMFA, study the original painting by Piet Mondrian, Victor Vasarely, Ben Nicholson, Franz Kline, and Jackson Pollock, among others.
- ◆ Supply the boys with white glue, burlap, acrylic paint in several colors and black and white, small wood scraps, wire, and a wooden base board 12” x 12”. Then go see what Louise Nevelson, Bontecou, and other did with similar materials.



*You may want to keep in mind that you can take all the boys projects and have an Art Fair at your next Pack meeting. This will help them to qualify for the ART ACADEMIC Beltloop. See the Art booklet for further details.*

# CUB ROCK

## June 2004

### Artist

#### ART MUSEUMS

Dallas Museum of Fine Arts, Fair Park, Dallas. Call (214) 426-2553 for info and guided tour, fee if applicable. Closed on Mondays

Museum of African American Life and Culture. Bishop College, 3837 Simpson-Stuart. Call 376-4311 for tour info and cost if any.

Kimbell Art Museum, 1101 Will Rogers Rd West, Ft. Worth. Call (817) 870-7686 for hours, info and cost if any. To get there: Take Montgomery St exit off of Dallas Ft. Worth Turnpike. Go right (or north) on Montgomery to Will Rodgers. There are signs all over the place pointing to museum.

SMU Meadows Museum of Fine Art. Bishop and Binkley Streets, Dallas. (Just off Hillcrest on SMU campus. Call 629-2740 for hours, info and guided tour. Excellent collection of Spanish art.

Owen Art Center. Adjacent to meadows (see above). Shows change. Usually contemporary art. Hours same as meadows

Amon Carter Museum of Western Art, 3501 Camp Bowie, Ft. Worth. Call (817) 738-1933 for hours and info. Closed Mondays. Near the Kimbell (see above)

Ft. Worth Art Museum, 1309 Montgomery, Ft. Worth. Call (817) 738-9215 for hours and info. Near the Kimbell. Contemporary collection. Exhibits change frequently

#### OTHER FUN

##### HOLOGRAMS

The Fringe Element, 2727D Routh, Dallas. Call 741-5215 for info Hologram Gallery. Holograms for sale

##### FOLK ART

Folk Art is a special art form. Visit International Folk Fest, St. Seraphim Orthodox Church, Throckmorton and Newton, Dallas in MAY Call 528-3741 for more info.



##### ART FESTIVAL IN DALLAS

Cityfest, held in Downtown Dallas in OCTOBER. Free admission. A celebration of the arts, sponsored by the Central Business District. Call 747-8555 for more info

**REMEMBER** when taking the boys to these location you can dove tail it into the **TRAVELER** activity badge, by letting them map the route, take the **DART**, etc. See **traveler requirements** for details.

# CUB ROCK

## June 2004

### Artist

#### SLIPPERY FINGER PAINT

*Materials:* 1 envelope unflavored gelatin 1-cup cold water  
1/2 cup cornstarch 1/2 cup mild soap flakes  
2 cups hot water medium size saucepan  
a small bowl heavy paper to paint on  
a large spoon jars or bowls for paint  
a stove powdered or liquid clothing dye  
(if liquid dye is used increase cornstarch to 3/4 cup)

In a small bowl, soak gelatin in 1/4 cup cold water. In saucepan, combine cornstarch and 3/4 cup cold water. Stir 2 cups hot water into starch mixture and cook over medium heat, stirring constantly until mixture comes to a boil. When mixture becomes smooth and creamy looking, remove from heat. Blend in softened gelatin. Add soap flakes and stir until mixture is thoroughly dissolved. Divide mixture into portions in bowls or jars. Add about a teaspoon of powdered dye or a tablespoon of liquid dye for each cup of mixture. Pan should be cooled before using. PUT ON OLD CLOTHES, COVER WORKTABLE with newspaper, and rub, smudge, or smear paint on paper. Tape or weigh down edges of paper to keep it from curling.



#### HOW TO MAKE A SILHOUETTE

Silhouettes of each den member make the meeting place take on new meaning. To make silhouettes, place Webelos on chair or stool in front of wall. Place a lamp or light, with light directed toward Webelos if possible, on the opposite side of the Cub from the wall. Hang paper, cardboard, or thin plywood on the wall, and trace the Cub's shadow. Cut it out, paint it black and mount (if desired) and hang. Changing the distance of the light from the subject can regulate the size of the shadow.

#### SQUIGGLE DRAWINGS

Give each den member a sheet of paper and have them make a wavy or zigzag line on the paper. Then have them exchange paper with another boy, who must turn the squiggle into a picture.

#### DRAWING CHARADES

Group is divided into two teams. Each has a large sheet of paper. Teams line up in relay fashion. On signal, the first boy in each line runs to a leader who gives him an object to draw. The boys go to the paper and draw his object. When the team recognizes what he has drawn, they tell the leader. If the answer is correct they get a point. The game continues until all members of each team has and a chance to draw.

# CUB ROCK

## June 2004

### Artist

#### TAG TEAM ART

Line den members up in relay fashion. Have a large piece of paper for each team taped on the wall or hung on an easel. Have the first boy begin drawing an object or design on the paper, without talking to anyone about what he is to draw. Allow him 30 seconds, then signal for the next boy. This boy adds to the original picture or design. Each boy has thirty seconds to draw. When each boy has had a turn or two (depending on how the picture is taking shape), signal; a stop. The den members should not confer about the drawing. When the signal is given to stop and all have "admired" their handiwork, have the first boy relate what the original object was to be and see what the finished project exactly looks like.

#### The Color Wheel

Fill in the colors on this color wheel as indicated.

Primary colors go in every other pie section. They are: \_\_\_\_\_, \_\_\_\_\_, \_\_\_\_\_.

Secondary Colors are created by mixing two Primary colors. Mix two primary colors together and find what they are: \_\_\_\_\_, \_\_\_\_\_, \_\_\_\_\_.

Fill in the remaining pie sections with the appropriate secondary colors.

What are three neutral colors? \_\_\_\_\_, \_\_\_\_\_, \_\_\_\_\_

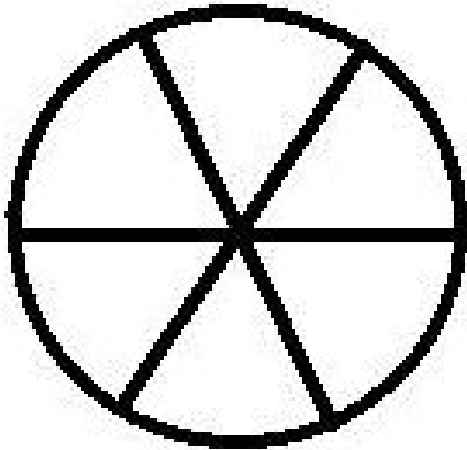

#### Complementary Colors

Complementary colors are those that are opposite each other on the color wheel.

Write down three pairs of complimentary colors.

\_\_\_\_\_ and \_\_\_\_\_

\_\_\_\_\_ and \_\_\_\_\_

\_\_\_\_\_ and \_\_\_\_\_

Can two primary colors be complementary to each other? \_\_\_\_\_

Can two secondary colors be complementary to each other? \_\_\_\_\_

# CUB ROCK

## June 2004

### Tigers - Snack Time/ Fresh Baking

#### Family Activity

The Kitchen can be a fun place of learning and provide hours of quality time for the two of you together. It's also the area of the house where you and your family probably spend the most time. So when you are looking for a time to squeeze in a fun activity with your child, it's the logical place to begin. Try creating games with food products. A game of sorting vegetables or fruits can help them practice counting as well as develop reading and math skills. A box of ziti or colored Fruit Loops are fun to string on waxed dental floss. This activity is a great for keeping a boy's attention while you stir up a quick meal

#### **Here are some thoughts to consider before beginning your kitchen fun:**

- 1) Select a cooking time when you can take a little longer in your preparation than usual.
- 2) Select a cooking time when you don't mind spills. You won't want to have family cooking night right after you've had the floors mopped.
- 3) Find a task that fits the age of your child. Preschoolers need projects that are completed in short amount of time.
- 4) Pick a time and day when your child hasn't already had a full day of activities.
- 5) Laugh and be silly when you can. Ever dabbed flour on a child's nose? You'll surprise your child and yourself as well.

#### **Useful kitchen gadgets that double as toys**

##### 1. Tongs

A simple pair of tongs can be used to serve spaghetti, remove a lost bay leaf from a stew, pluck boiling baby bottles and nipples from a pot or toss a salad. Get a pair that locks in the closed position for easiest storing. Young children will enjoy practicing their coordination in picking up marshmallows or pieces of fruit while you are preparing meals.

##### 2. Garlic Press

A good garlic press not only makes crushing garlic easy but also can squeeze juice from a piece of fruit or an onion. For fun allow your child to push cookie dough through the press to make "hair" for decorating gingerbread cookies or animals on cupcakes.

##### 3. Melon Baller

How many times have you picked the seeds out of fruit for a child? When you aren't using this tool for making melon balls, try it for coring pears and apples. It makes the perfect size scooper for children to dish out cookie dough on to a cookie sheet too! And for fun how about making mini ice cream balls that can be piled up to build crazy desserts.

##### 4. Assortment of Cookie Cutters

Metal cookies cutters can be used for making lots of delicious treats and family fun. Press a fun shape into a sandwich to bring life to a pbj or place one into a skillet and pour pancake batter inside to form a new kind of pancake. And when you are done using the cutters for cooking purposes, allow your child to trace their shapes for entertaining arts and craft projects.

<http://www.bluesuitmom.com/food/activities/kitchenfun.html>

# CUB ROCK

## June 2004

### Tigers - Snack Time/ Fresh Baking

#### Den Activity

#### EVERYONES FAVORITE BREAD!

How many different types of bread can you find?

There are many different types of bread. It may be different in size, shape, color, taste or texture.

How many different types of bread do you know? Make a list.

After everyone has made their list then each partner names off a type of bread they have listed. If some else has it then everyone with the name must remove it from their list. Who ever has the most types of bread left on their list after all have been named is the winner.

#### MEXICAN ROLL UPS

##### *Ingredients*

*1 flour tortilla*  
*1-2 tablespoons cream cheese*  
*1 tablespoon shredded carrots*  
*1 tablespoon sliced olives*  
*1 tablespoon chunky salsa*

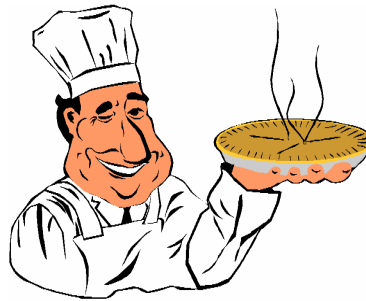

##### **Directions**

Spread the cream cheese over the flour tortilla. Spread the olives and carrots on top of the cream cheese and then follow with the salsa. Roll up the tortilla and eat cold or microwave, seam side down, uncovered on high for 15-30 seconds

#### FRUIT KABOBS

##### *Ingredients*

*strawberries*  
*grapes*  
*cantaloupe (use a melon baller)*  
*honey dew melon (use a melon baller)*  
*orange sections*  
*banana pieces*  
*fruit flavored yogurt*  
*skewers (available at all grocery stores)*

##### **Directions**

Take the fruit pieces and slide them up the skewer in alternating order. Use your imagination here. Any fruit! Any order! Go nuts with your creativity.



# CUB ROCK

## June 2004

### Tigers - Snack Time/ Fresh Baking

#### Den Activity

##### **ZIPLOC ICE CREAM**

###### *Ingredients*

*1/2 cup half and half*

*1/2 teaspoon vanilla extract*

*1 tablespoon powdered sugar*

*2 tablespoons rock salt*

*ice*

*1 sandwich sized ziploc bag*

*1 gallon sized ziploc bag; a coffee can with a lid or a plastic Tupperware container with a lid.*

###### **Directions**

Add the half-and-half, vanilla and sugar to the small bag, seal tightly. Add, to either the larger ziploc bag, coffee can or Tupperware, half the ice then sprinkle with half the salt. Add the small bag and cover with the rest of the ice and salt. Whichever container you use, be sure it's filled to the top with ice. Seal or put the lid on your container and shake...shake...shake! 10 - 15 minutes

###### Other flavorful ideas:

Add a teaspoon of cocoa to your bag for chocolate ice cream.

Add a tablespoon of chocolate chips

Add a tablespoon of toasted almonds

Add a tablespoon of cookie crumbs

Add a tablespoon of finely chopped strawberries (make sure to drain them!)

Add a tablespoon of chopped banana

##### **CRUNCHIES**

###### *Ingredients*

*4 1/2 cups graham cracker*

*1 cup peanuts, chopped*

*1/4 cup peanut butter*

*2 cups semisweet chocolate chips*

*1 cup evaporated milk*

*1 teaspoon vanilla extract*

*30 mini muffin cups*



###### **Directions**

In a medium sized bowl, combine cookie crumbs, peanuts and peanut butter and mix thoroughly. In a small saucepan, melt the chocolate chips and milk over low heat, stirring constantly until smooth. Remove from the heat and add vanilla. Pour chocolate mixture over crumb mixture and stir until well blended.

Set the mini muffin cups on a baking sheet and fill them 3/4 of the way with the peanut-cookie mixture. Chill for 1 hour or until the bites are firm.

# CUB ROCK

## June 2004

### Tigers - Snack Time/ Fresh Baking

#### Den Activity

##### CHOCOLATE TARANTULAS

###### *Ingredients*

*3 cups chow mein noodles*

*2 cups chocolate chips, melted*

*1 cup of chopped peanuts or almonds*

###### **Directions**

Combine the noodles and nuts in a large bowl. Melt chocolate chips over a double boiler or in a microwave. Pour the melted chocolate over the noodles and mix well. Moving quickly, drop about 2 tablespoons of the mix onto a parchment or wax paper lined baking sheet. If you pop the sheet in the refrigerator they will set up quickly!

#### Go See It Outing

- ◆ Go to a local bakery.
- ◆ If available in your town go to a facility where food is made or processed.
- ◆ Go to a cooking school.
- ◆ Go to a restaurant and see how the food is prepared
- ◆ Attend a cooking contest.



# CUB ROCK

## June 2004

### Cubmaster Corner - Den And Pack Newsletters

#### DEN & PACK NEWSLETTERS

Communication is the complex process of transmitting and receiving signals. Words mean different things to different people. Confidence and poise comes through slow, deliberate talking. Tension sometimes comes from fast-talking. Body language can communicate more than words in some instances. Communications are most likely to succeed when both the sender and receiver assume 100% responsibility of getting the message across.

#### COMMUNICATION IS THE KEY

Communications between pack leaders and parents is vital. It is important for a person to know to transmit his ideas so that they convey what he intends. Putting yourself in the other person's shoes...looking at the situation from his point of view...empathy...is always helpful.

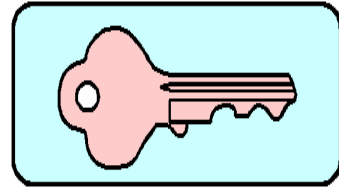

There are a variety of techniques that can be used to improve communications with the pack. Some of the methods are considered "one way", the simple transmitting of ideas. Other methods are "two way", the exchange of ideas. This list is not exhaustive. Use your imagination and create unique ways to communicate in the pack.

**YEARLY CALENDAR:** Each year at the annual planning meeting the pack should set the monthly themes for the programs for the next 12 months. Along with the themes, the pack meeting dates, times, and places can be set. This information is vital and should be shared with every family in the pack as soon as it is available.

**SURVEY SHEETS:** This communication device really falls in the category of information gathering. If each family completes a survey sheet then valuable information is in the hands of the Cubmaster and Den Leaders.

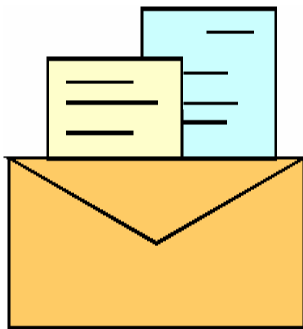

**POSTERS:** Posters help tell what is going to happen or what has occurred. A den can use posters to tell what activities they have done when the event does not lend itself to display at pack meeting. A poster can also place emphasis on an upcoming event more effectively than the pack newsletter.

**SKITS:** Communication that takes the form of "one way" does not always have to be in a written format. A skit about next month's bicycle rodeo or the parent-son cake bake will add more fun and variety to a pack meeting. It can help make others more aware of an upcoming event.

**NEWSLETTER:** Is there a problem keeping leaders, parents and boys aware of what is going on? If so a pack newsletter can alert everyone to the event that the pack has scheduled and perhaps get volunteers for special events. A newsletter is a one way form of communication. A newsletter can be passed to parents at the monthly pack meeting. If arrangements can be made in the pack budget, the newsletter can be mailed to the home of each Cub Scout. While it will cost, everyone will get a copy of the important information.

Communication is the name of the game-but producing a newsletter is not a game. As games have rules, there are guidelines to clear communication.

# CUB ROCK

## June 2004

### Cubmaster Corner - Den And Pack Newsletters

#### ASK YOURSELF

Is there enough information that needs to be given to the pack parents that would warrant having a newsletter?

What do you want to accomplish by publishing a newsletter? The newsletter can serve several functions, such as informing, educating, promoting and entertaining.

Who will be reading the newsletter? Each family should receive a newsletter, as well as the sponsoring organization, hometown newspaper, and prospective Cub Scout families.

Resources- Different types of jobs that need to be accomplished in putting a newsletter together.

Writing the article  
Editing the written material  
Proofreading  
Typing  
Designing layout  
Drawing. Layout  
Collating/ Stapling & Mailing



#### ANSWERING OTHER QUESTIONS

Once it has been determined that communication by newsletter is the best method for your pack, there are other questions that need answered. Will the pack finance, or is there a parent who can make copies at their work place? Who will assume which duties to assure that it is out on time? Will it be mailed or distributed at the pack meeting? These questions may need clarification before publication begins.

The editor “gets it all together”. The editor’s duties and responsibilities should be clearly understood by the editor and the pack committee. Get it down in writing to avoid problems and confusion. Remember why you are doing the newsletter.

#### SOME STORY IDEAS:

News about membership

Notices of policy changes of special activities

Notices of upcoming events

Recognition of boys & leaders

Calendar of events  
concise, and correct

Make sure stories and articles are clear,

Friends of Scouting information

# FIN FUN

## July 2004

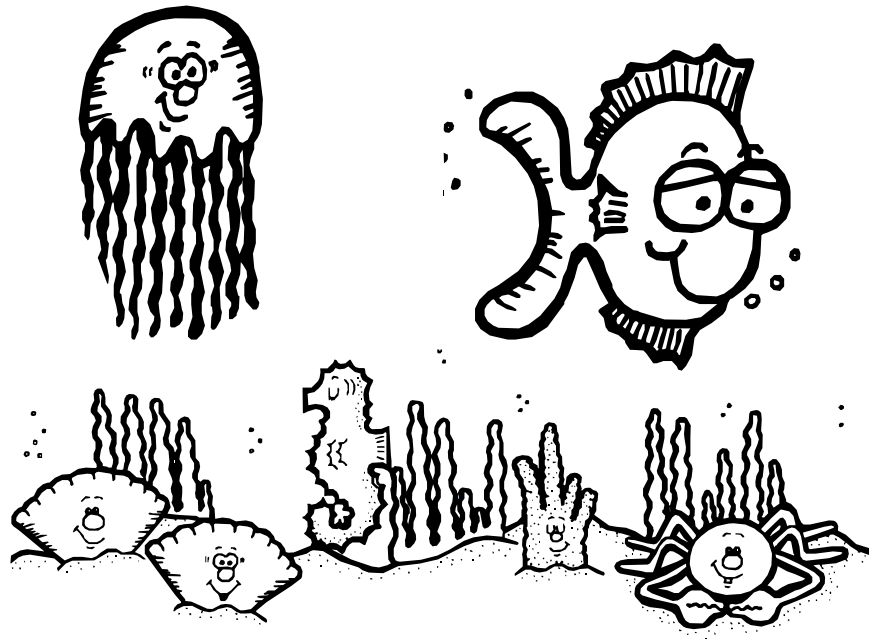

Dive right in as our Cub Scouts spend a month learning about water, our most precious resource, and the many creatures that live in our oceans, lakes, and rivers. Dens can visit a local aquarium or fish farm. You may want to try your hand at fishing. Cub Scouts may even want to prepare their own aquarium or fish bowl and "adopt a gold fish." This is also an excellent opportunity to teach our Cub Scouts about water conservation and "catch & release" programs. Don't forget learning about water safety. So hit the beaches, there's a lot to "sea!"

Cub Scout Theme .....	03
Webelos – Aquanaut .....	17
Webelos – Geologist .....	20
Tigers - Safety in the Sun/ Fun in the Water .....	22
Cubmaster Corner - Delivering Cubmaster Minutes .....	29

# FIN FUN

## July 2004

### Our Best Selves – Circle Ten Pow Wow, Author Unknown

The good you find in others, is in you too.  
The faults you find in others, are your faults as well.  
After all, to recognize something you must know it.  
The possibilities you see in others, are possible for you as well.  
The beauty you see around you, is your beauty.  
The world around you is a reflection, a mirror showing you the person you are.  
To change your world, you must change yourself.  
To blame and complain will only make matters worse.  
Whatever you care about, is your responsibility.  
What you see in others, shows you yourself.  
See the best in others, and you will be your best.



Give to others, and you give to yourself.  
Appreciate beauty, and you will be beautiful.  
Admire creativity, and you will be creative.  
Love, and you will be loved.  
Seek to understand, and you will be understood.  
Listen, and your voice will be heard.  
Teach, and you will learn.  
Show your best face to the mirror, and you'll be happy with the face looking back at you.

# FIN FUN

## July 2004

### Gathering Activities

#### GATHERING OF THE SCHOOLS

Pin pictures of fish on people as they arrive. Have cutouts of swordfish, tuna, trout, catfish, etc. On signal, they are to see which "school of fish" can assemble first.



#### SCRAMBLED WATER

Scrambled below are the names of different kinds of bodies of water. Can you unscramble them?

KEAL	_____	FULG	_____
NECOA	_____	GOANOL	_____
YOUBA	_____	DROJF	_____
NOPD	_____	VERIR	_____
LENIT	_____	CALAN	_____

Answers: Lake, Gulf, Ocean, Lagoon, Bayou, Fjord, Pond, River, Inlet, Canal

#### GUESS THE FISH EGGS

As they enter, have participants guess the number of "fish eggs" (small jelly beans) in a jar. The winner is awarded the jar during the closing ceremony.

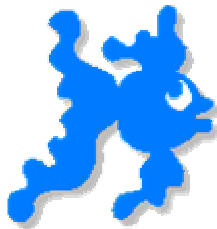

#### FISHY APPLAUSE

Have each person reach into a large tub covered with Blue saran wrap (slit cut in middle for hand to go in) and catch one fish. Write names of several different fish on the back of the fish cutouts " bass, swordfish, tuna, catfish, trout, flounder, squid, rockfish, salmon. Tell everyone to find other "fish" of the same kind. Have each "school" create an applause about their fish, to be performed at appropriate times during the pack meeting.

#### *Ways to Say "Thank You"*

Packs, dens and leaders should take every opportunity to thank leaders and family members who assist with activities. Here are a few ideas for fun "thank you's".

- **"Anchor" thank you:** "With you as its anchor, the den (pack, etc.) is sure to stay afloat. Thanks!"
- **"Ship" thank you:** "Once you learn to do your best, the rest is easy sailing. Thanks!"
- **"Ships' flag" thank you:** You serve us with flying colors. Thanks!"

#### *Announcements:*

You might "fish" the announcements from a hidden "fish pond." (Set up a screen and have a helper attach the "fish" to your "hook" " a clothespin " each time you cast it into the pond.) This is also a good way to give out awards.

# FIN FUN

## July 2004

### Openings

#### SEA ADVENTURES

Each of the thirteen Cub Scouts holds a large card. On one side of each card is one of the following letters, and on the other side is the accompanying saying. Each Cub Scout raises his card to reveal the letter as he reads the saying. When finished, the card should spell SEA ADVENTURES.

S is for SCOUTING, a well rounded activity.  
E is for EACH Cub Scout doing his best all the time.  
A is for AWARENESS of our water resources and protecting them.

A is for ALL people working to save our oceans and the creatures that live within.  
D is for DEPENDABILITY, which we always are.  
V is for VICTORY in helping to save our planets oceans, rivers, and lakes.  
E is for the EXCITEMENT of help our water animals.  
N is for our NATION, of which we are all proud.  
T is for THOUGHTFULNESS as we think about keeping our planet clean.  
U is for UNTIED, as we all work and play together.  
R is for RECOGNITION for jobs well done.  
E is for ENTHUSIASM when do our daily good turn.  
S is for the SERVICE we can give to our community

#### OCEAN

*Have large cards with the letters O C E A N on them for the Cubs to hold and read from.*

Cub #1: O – O is for Old Glory that we wave with pride.

Cub #2: C – C is for colors we see each night with joy.

Cub #3: E – E is for evenings that give us pleasant thoughts.

Cub #4: A – A is for awareness of the beauties of the sea.

Cub #5: N – N is for Neptune, the mythical God of the sea, who rules his kingdom with love.

Leader: Put it all together, it is OCEAN, it borders our land and gives us much to be thankful for.

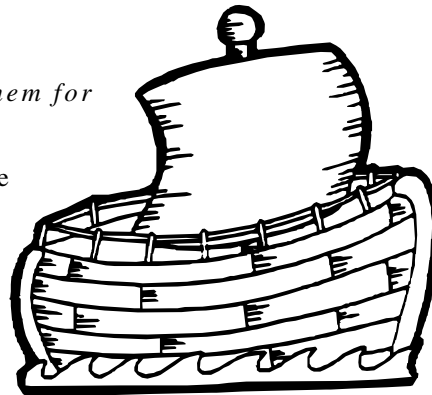



# FIN FUN

## July 2004

### Den Activities

#### WATER SAFETY

Before you take your pack or den out for any water-related activities, please read:

- ◆ Safe Swim Defense
- ◆ Home Swimming Safety Rules
- ◆ Water Rescue
- ◆ Safety Afloat

#### PLAY SAFE AND HAVE FUN

Most cities offer recreation swimming at their pools with qualified lifeguards on duty. Call your city's parks and Recreation Department or community Services office for specific locations, hours and fees. Some YMCA offices open pools outside their normal facilities for more affordable fees. Call the YMCA near you for more information. Some pools require letting them know ahead of time if you are planning to bring a large group so that they can arrange to have more lifeguards on hand.

#### PACK AND DEN ACTIVITIES

- ◆ Raingutter Regatta
- ◆ Pirate Picnic
- ◆ Water Carnival
- ◆ Fishing Derby

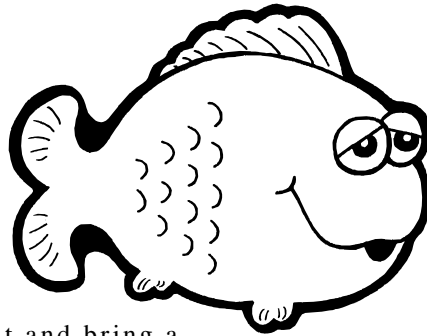

#### BACKYARD WATER PARTY

Make sure you tell everybody to come in a swimsuit and bring a towel to dry off with afterwards. Some suggested activities:

**Water slide** - Spread an old plastic shower curtain or heavy duty drop clothe on the grass. Anchor the corners with plastic jugs filled with water. Lay a hose at one end. Adjust the nozzle for fan spray and turn on the water. When the plastic is completely wet, jump in front of the hose nozzle and start sliding. Make up contents as to who can go the fastest or farthest, who can do the most spins, and so on. You may want to move the water slide to a new place after half an hour to avoid damaging the lawn.

**Ice Block slide** - If the area you are holding the party has a slope, buy a big block of ice. Place a towel over it. Sit on the ice and slide down the slope.

**Glove sprinkler** - have some wild, wet fun with a hose and an old kitchen rubber glove. Cut small holes in the fingertips of the glove and attach the wrist of the glove to the end of the hose using several elastic bands or some string. Turn on the water and look out!

**Have a water spray fun** - Use sprayer, squirt guns, water balloons, or fill a bucket with sponges and water and toss them at each other.

# FIN FUN

## July 2004

### Crafts

#### PAPER PLATE CRAB

If you don't have a paper plate, trace a regular plate on a piece of cardboard (old cereal box) or use a margarine container lid.

#### MATERIALS NEEDED

*paper plate or alternate*

*Pipe cleaners- 9 of these. If using snack size plate, cut pipe cleaners in half*

*1 inch pieces of drinking straw*

*hole punch*

*markers or paint*

#### INSTRUCTIONS:

- ◆ Punch 8 holes around the edge of the plate.
- ◆ Thread pipe cleaners through holes and twist to secure.
- ◆ Put three pieces of straw on each of the pipe cleaners (representing real leg segments)
- ◆ Bend legs to shape and make them look like they are walking.
- ◆ Punch two more holes, close together in the front and put 1 pipe cleaner through with ends sticking up. Twists to secure add beads to the end to represent eyes.
- ◆ Color or paint paper plate.

#### WHALE IN A BOTTLE

[www.angelfire.com](http://www.angelfire.com)

Fill a two liter pop bottle one quarter full with water (tint blue food coloring). Fill a balloon with small amount of water (2 or 3 tablespoons should be enough). Fill the balloon with just enough air to hold its shape, tie the end, push into bottle, add stones, shells, gravel, etc.



#### PLASTIC MILK JUG WHALE

##### Material Needed:

*clean plastic milk jug*

*knife and scissors*

*black permanent marker*

*low temp glue or glue that will work on plastic.*

##### What to do:

1. Draw the mouth shape as shown around the bottom of the milk jug with a marker (use a marker that will wipe off in case you make a mistake). Poke a whole in the marked line with a knife so that you will be able to insert your scissors. Cut out the mouth in one piece. This piece will be used for the whale's fin.
2. Cut two slits in the screw top so that you will be able to insert the fin.
3. Shape the mouth piece to cut it into a fin shape as shown in the diagram.
4. Insert the fin into the two slits you made on the milk jug and glue it in place.
5. Use a permanent black marker to trace around the mouth, draw in eyes, and lines on the fin.

[www.daniellesplace.com](http://www.daniellesplace.com)

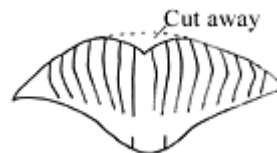

# FIN FUN

## July 2004

### Songs

#### **BLOW YOUR BOAT**

*Tune: Row, Row, Row your Boat*

Blow, Blow, Blow your boat,  
Fast along the waves.  
Do your best, do your best,  
We're the Cub Scout braves.

Blow, Blow, Blow your sail,  
Passing others by  
Do your best, do your best,  
Aye-Aye-Aye

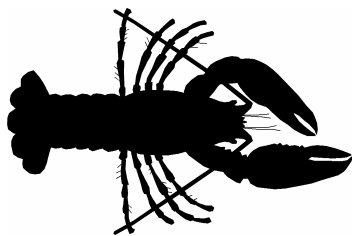
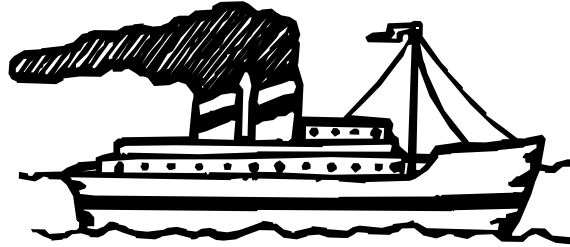

#### **LOBSTER, STARFISH**

*Tune: The Old Gray Mare*

Lobster, starfish, octopus and tuna fish,  
Octopus and tuna fish, octopus and tuna fish,  
Lobster, starfish, octopus and tuna fish,  
Live in the deep blue sea,  
Live in the deep blue sea,  
Live in the deep blue sea,  
Lobster, starfish, octopus and tuna fish,  
Live in the deep blue sea.

Next verse use:  
Flounder, porpoise, mackerel and flying fish

#### **AT THE SEASHORE**

*Tune: Are You Sleeping*

Finding seashells  
At the seashore  
Salty mists  
Spray my face  
Cool sea breezes fan me  
And the ocean water  
Feels so good,  
Feels so good.

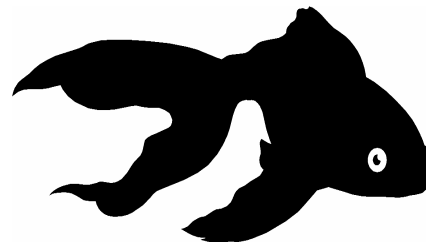

#### **TWELVE DAYS OF VOYAGE**

*Tune: Twelve Days of Christmas*

On the first day of voyage, my captain gave to me  
A seagull on a dinghy.  
2 tug boats  
3 winches  
4 spinnakers  
5 golden cleats  
6 skippers shouting  
7 crewman climbing  
8 storm flags flapping  
9 schooners tacking  
10 anchors dropping  
11 tillers turning  
12 buoys bobbing

# FIN FUN

## July 2004

### Skits



#### THE FISHING TRIP

*Make a cardboard cutout of a boat and a sign that says "Boat Dock". The scene starts with the boat about 10 feet away from the boat dock. The Cub Scouts and their Den Chief are on their way to go fishing. The first Cub Scout stops at the dock then walks out across the water and gets in the boat.*

Cub #2: Hey wait for me! (He walks out to the boat.)

Den Chief: Oh well... (Steps into the water and pretends to fall in and drags himself out)

Cub #3: Hey wait up. Here I come. (Walks out to the boat.)

Den Chief: (Tries and fails again. The sequence continues until all the boys are in the boat and only the Den Chief remains on shore. Finally...)

Cub #1: Should we tell him where the rocks are?

#### SHIPS THAT PASS IN THE NIGHT

Cub #1: If the Pilgrims came over on the Mayflower, how did Cub Scouts get here?

Cub #2: I don't know. How?

Cub #1: On handy crafts (*Cub Scout enters with sign reading "Handicraft".*)

Cub #3: If the Pilgrims came on the Mayflower and Cub Scouts came on handy crafts, how did doctor's get here?

Cub #4: How?

Cub #3: On blood vessels. (*Cub Scout dressed as doctor enters.*)

Cub #5: How did students get here?

Cub #6: I don't know. How?

Cub #5: On scholarships (*Cub Scout enters wearing academic cap and gown.*)

Cub #2: How did all the ordinary people get here?

Cub #1: I'm stumped. How?

Cub #2: On citizen ships, of course. (*Cub Scout enters carrying get-out-the-vote sign.*)

Cub #4: And how did the barbers get here?

Cub #3: I know! They came on clipper ships (*Cub Scout dressed as barber enters.*)

Cub #6: How about movie stars?

Cub #5: How?

Cub #6: On the showboat. Some came on dreamboats, of course. (*Cub Scout dressed as song and dance man enters.*)

Cub #4: And finally, how did all the hot heads get here?

All: On steamships, naturally. (*All face audience and bow.*)

# FIN FUN

## July 2004

### Games

#### CLAM DIG

For every player, hide at least four peanuts (in the shell) in the sand. Divide into teams and give each team a spoon and a bowl. At a signal to go, a player from each team runs across the field to the sand pile, digs up a peanut, puts it in their bowl, and returns so the next player can go.

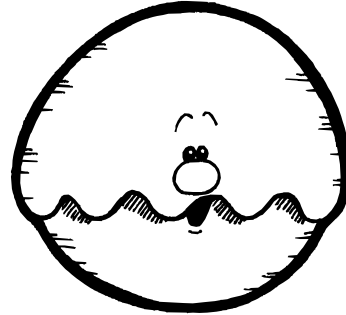

#### CRAB RACE

This activity requires a hula-hoop for each group of four boys. Have each group of four climb inside a hula-hoop, back to back. The teams must then race to a finish line. The boys must keep their hands outside the hula-hoop while they race, holding it up only with their bodies.

#### DIP, DRIP and DUMP

Divide the group into two or more equal teams. In front of each team place a bucket of water and two small plastic cups, each with two small nail holes near the bottom. About twenty feet away, place two bottles with small necks, such as soda bottles. On signal, the first player on each team dips the plastic cups into the bucket, runs to the soda bottles, and dumps any remaining water into them. He then runs back and hands the cups to the next player, who repeats the action, and so on, until the soda bottles are filled to a certain level.

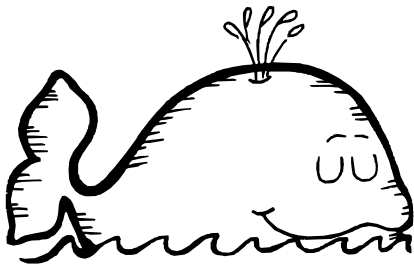

#### FISHERMAN AND SHARKS

Form two equal groups and with a string or chalk make a circle large enough to hold one group. They are the "Fishermen". The other group forms outside the circle. They are the "Sharks". The fishermen try to pull the sharks from the sea. The sharks in turn try to pull the fishermen into the sea. Any boy who is pulled or accidentally steps into the territory of the other side is out of game. The side with the most members at the end of 5 minutes wins the game.

#### FLOATING TRAGET

Float an aluminum pie plate in a tub of water. Give each player ten beans. In turn, the players try to toss their beans onto the plate from a distance of about five feet. Score 10 points for each bean that stays on the plate.

# FIN FUN

## July 2004

### Games

#### LAND THAT FISH RELAY

Divide into two teams. The first boy on each team runs to a line and picks up a net and rubber ball. He bounces the ball behind him and quickly turns around and nets the ball before it hits the ground. He then places the net and ball on the ground and returns to tag the next boy in line.

#### WET T-SHIRT RELAY

Any number of players is possible in this game. Divide the boys into equal teams. For each team you will need a large bucket of water and an over-sized T-shirt. Have the boy's line up behind each other in their teams. At the opposite end of the playing area, place a bucket of water with the T-shirt in it. At the "GO" signal, the first boy from each team runs down to his team's bucket, takes out the shirt and puts it on (head and arms must be in the right holes). He then runs back to his team, removes the shirt, gives it to the next boy, who runs down, dunks it in the bucket and then puts it on (head and arms in holes, but inside out is O.K.) and runs back to his team. This is repeated until all have had a turn. First team done is the winner. It's very wet, but very fun.

#### KNOCK DOWN THE SPONGE

Place three sponges on end on a table or on a board laid across two chairs. Stand players back about 8 feet and give each 3 tennis balls to throw and knock the sponges over or off according to your setup. The one knocking the most sponges wins.

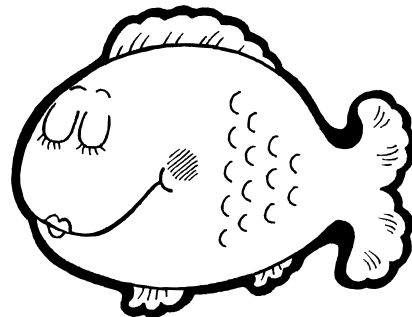

#### SPONGE IN HOOP

Place a plastic hoop or some sort of target flat on the ground. Stand 6 or 8 feet away and try to toss wet sponges into the center of the hoop. Experiment with soaking wet and wrung-out sponges—they bounce differently! The one with the most sponges inside after five tries wins the game.

#### SPONGE RELAY RACE

You'll need 2 sponges, 2 buckets, 2 bowls and water. Have boys line up in two teams and the boys at the front of each row hold a bucket of water with the sponges in it and the boys at the end of each row hold a bowl. The first boy takes a wet sponge out of the bucket and hand it to the next boy and so on till it reaches the last boy in his row who squeezes the water out of the sponge and into bowl. He then races it back to the front and puts it back into the bucket starts over again. Play continues until the water is gone or a certain time is up. The team, who has the most water in the bowl at the end, wins the game.

# FIN FUN

## July 2004

### Advancement Ceremonies

#### SEE WHAT YOU CAN SEE

CM: For thousands of years people have grouped the stars together as figures or constellations. Men who were on ships probably did this. The stars helped them find their way across many oceans. Some nights they would stare into the night and just look at all the many stars. They could visualize stars forming pictures of heroes, kings, queens, men, maidens, and monsters. The best know constellation is the Big Dipper. Beginning with stars forming the lower side of the Big Dipper, sight upward. The brightest star you will find is the North Star, which for centuries was the guiding star of travelers. It remains in the same place all the time. Be like the North Star. Let your light shine to help others find the way. Now, what or who can be your guiding star everyday?

Cub #1: The Cub Scout Promise

Cub #2: The Law of the Pack

Cub #3: The Bible

Cub #4: My minister, bishop, priest, or rabbi

Cub #5: My teacher

Cub #6: My mother and father

CM: Will the parents of our advancing Cub Scouts and the advancing Cubs please come forward? We would like to present you parents with your son's badge. We give you the honor of presenting it to your son, since you have guided him along his advancement trail. Congratulation and happy scouting!

#### SEA ADVENTURES

CM: When a boy wanted to be a sailor, he would hire himself on as a cabin boy. There he learned the terminology of the ship. He learned his knots and the rigging.

CM: When a boy wants to become a Cub Scout, he must learn the basics of Scouting. When he learns the Promise, the Law, the sign, the salute, the handshake, the meaning of Webelos, and the motto, a boy then becomes a Bobcat. Will the Bobcat recipients please come forward with their parents?

*(Present awards to parents to pin on their son)*

CM: A sailor boy's knowledge of the sea did not end there. As he traveled about the world, he saw many different types of ships and their uses. His world would become larger. So too, does a Cub Scout grow. He learns about his national flag, about his family and world, about tools, and about many other things. It is then that he is recognized as a Wolf. Would our Wolf Cubs and their parents please come forward?

*(Present awards to parents to pin on their son)*



# FIN FUN

## July 2004

### Advancement Ceremonies

#### SEA ADVENTURES Continued

CM: A sailor even today has to know the methods of ship communication, whether it be flags or radio. He needs to know about radar. A Bear needs to be more aware of God and worship, more about wildlife and the environment, more about family life and more about strengthening his body. Will our Bear rank recipients and their parents please come forward?

*(Present awards to parents to pin on their son)*

CM: A sailor soon learns about tides and the sea currents. He learns to use these to travel. A Webelos Scout must earn several different kinds of activity badges to help prepare him for the future. Will our Webelos and their parents please come forward?

*(Present awards to parents to pin on their son)*

CM: Finally, a sailor has a destination, a goal; he must know where he is and how to get where he is going. He uses the constellations and the North Star to guide him. He uses a compass and a sextant to chart his course. So, too, does a Webelos Scout. He has earned more activity badges to give him skills for the future. He has visited Boy Scout troops, as he plots his course. He has filled out a Boy Scout application form. He is deciding on his goal, maybe even an Eagle Scout. Will our Arrow of Light recipients and their parents come forward?

*(Present awards to parents to pin on their son)*

#### SCHOOL OF FISH ADVANCEMENT

**Equipment:** A poster board or a sheet colored blue imitating water gradually getting deeper, four different size fish made of cardboard, awards.

**Setting:** Cubmaster is in front of room with water behind him.

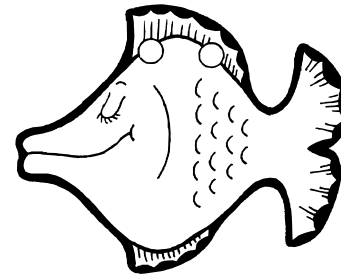

**CUBMASTER:** The small fish starts out in shallow water (Place smallest fish in shallow water) and the first step is to learn how to maneuver in the water, just as our beginning Scout is becoming familiar with Cub Scouting. The first part of becoming a Cub Scout is that of a Bobcat. Would the following boys please come forward with their parents? (Award badges)

As our small fish becomes stronger and larger (place the next fish further out in the water) he moves further into the water finding new adventures and discovering new areas. Just as our fish is developing so is our Cub Scout. The next step is that of a Wolf. Would the following boys please come forward with their parents? (Award badges and/or arrows)

Our fish has grown into a larger fish (place 3<sup>rd</sup> fish further out in the water) and has moved out further into the water becoming more acquainted with the other fish and is learning to maneuver faster in the water. Just like the fish, the Cub Scout is learning and meeting more challenges and is becoming more acquainted with the pack. The next step is that of the Bear. Would the following boys please come forward with their parents? (Award badges and/or arrows)



# FIN FUN

## July 2004

### Advancement Ceremonies

#### SCHOOL OF FISH ADVANCEMENT *continued*

Our fish has finally reached the stage where he can go into the deepest water (place largest fish in the deepest water) and has learned quite a lot about the water and what lies in it. This stage of growth is like that of the Webelos. The Webelos has matured and learned much about the pack and is ready to move on into Boy Scouting. Would the following boys please come forward with their parents? (Award Webelos badge and/or activity pins)

Just as the fish has developed and has gone out into deeper water, we know our Cub Scouts have learned and developed as we send them on into Boy Scouting and beyond.

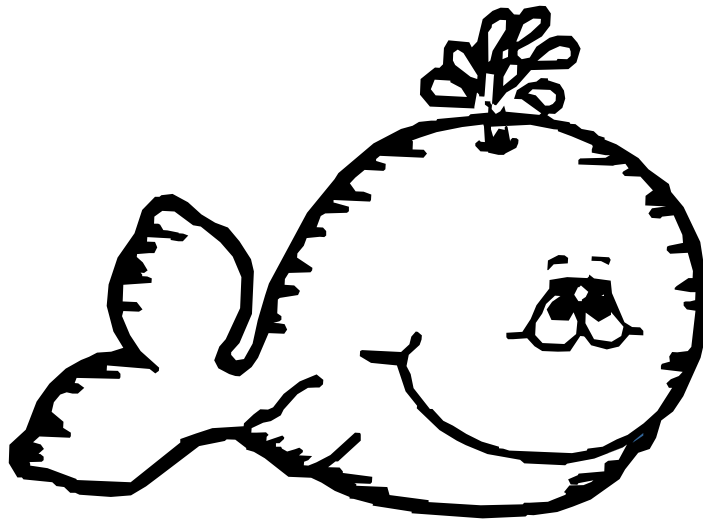

# FIN FUN

## July 2004

### Run On/ Applause

#### RIDDLES

What fish would an actor like to be?	Starfish
What fish should wear a crown?	Kingfish
What fish might say, 'Bow wow'?	Dogfish
What fish can play in a band?	Drumfish
What fish might chase a mouse?	Catfish
What fish may be found on a boat?	Sailfish
What fish is the best fish of all?	Angelfish
What do sharks like to eat with peanut butter sandwiches?	Jellyfish
What kind of cat lives in the ocean?	An octopus

#### RUN ON

- Boy: How many fish have you caught?
- Fisherman: None yet. But I've only been fishing for an hour.
- Boy: That's better than the man who was fishing here yesterday.
- Fisherman: How's it better?
- Boy: It took him five hours to do what you've done in just one!

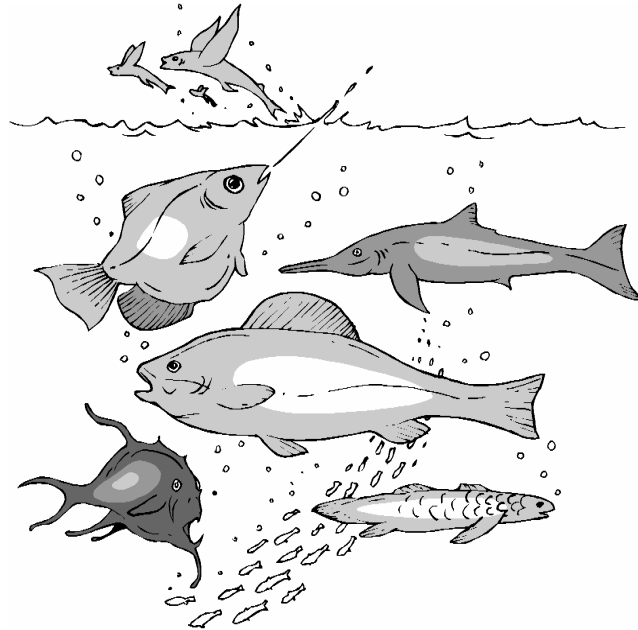

#### APPLAUSE

- Ocean - Best done with a large group; have first row sway from side to side, second row swaying in opposite direction; third row same as first, etc. The n have them add sound effect: SWOOSH, SWOOSH, SWOOSH!
- Regatta - Hold your right hand palm up in front of your mouth and pretend holding a sailboat. Release the boat with a series of puffing blows.
- Beach Cheer - Divide the audience into three groups. When you point to group one, they yell, "Sand." When you point to the second group, the yell. "Surf." When you point to the third group, they yell, "Sun." vary the order and speed at least three times.

# FIN FUN

## July 2004

### Closings

#### BEACH PARTY

*Setting: Cubmaster carries a water squirter and a beach towel. Now he lays them down after wringing out some imaginary drops of water from the towel.*



Well we've come to the end of another fun, fishy, delightful pack meeting. In planning a successful activity for Cub Scouts age boys, there are five essential ingredients to include:

First is ACTION. Boys find it impossible to sit and do nothing. Action makes everything much easier. Today we had ACTION!

Second is SOMETHING TO WATCH. Watching and helping celebrate another's accomplishments and hard work is one of the best ways to have fun watching

Third is having SOMETHING TO TALK ABOUT. It's fun for Scouts to hear adults telling stories and fun for them to do things that are worth talking about later. I think we accomplished that today.

Fourth is SOMETHING TO LAUGH AT. We all need to enjoy laughter, and sharing fun experiences is one of the best ways to do that. Did we succeed with laughter?

Fifth is SOMETHING TO HELP WITH. Parents, leaders and family members are involved in helping Cub Scouts move along on their trail toward Bobcat, Wolf, Bear, Webelos, and Arrow of Light. But just in case you missed out on helping this week, we have one more chance -- after the retiring of the colors, you can all HELP with the cleanup!



#### WATER Cubmaster Minute

"We've had plenty of fun with water tonight, but as we leave, let's take a moment to remember what a precious resource water is, especially in the heat of the summer. We play in it, we bathe in it, and we drink it. We eat the fish that live in it. We use water to irrigate our crops and our lawns. Without water, our earth would be as lifeless as the moon. Let's all do our best this month to help conserve this great natural resource.

# FIN FUN

## July 2004

### After the Meeting

#### CUP O FISH

*blue Jell-O*  
*gummy fish (or fruit-flavored sharks)*  
*clear plastic cups.*

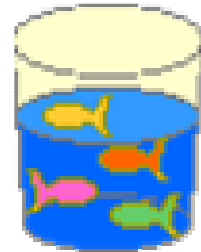

#### DIRECTIONS

- ◆ Make blue Jell-O according to the directions on the box.
- ◆ Pour into clear plastic cups.
- ◆ Let them cool in the refrigerator until partially set - about an hour.
- ◆ When they're partially set, place a few gummy fish in each cup.
- ◆ Put them in the refrigerator until they're completely set.

Variation:

An entire punch bowl of fish Jell-O (made like the cup o' fish)!

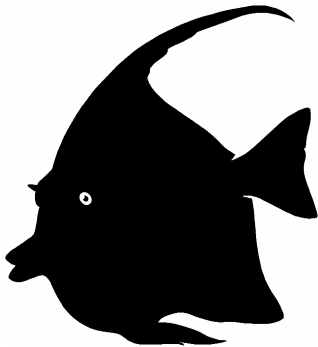

#### FISHY SNACK

*1 8 ounce pkg. cream cheese, softened*  
*blue food coloring*  
*rectangular crackers*  
*gold fish crackers*

#### DIRECTIONS

- ◆ Add a couple drops of coloring to cream cheese and mix.
- ◆ Spread onto rectangular crackers.
- ◆ Put gold fish crackers on top

#### LET'S GO FISHING

Give the boys pretzel sticks, a dollop of peanut butter, and fish crackers!  
The boys can dip their pretzel sticks into the peanut butter and "catch" the fish crackers, then eat what they catch!

# FIN FUN

## July 2004

### Aquanaut

#### WATER GAMES

**For Non-Swimmers or Poor Swimmers: To help them overcome fear of water.**

##### **BALL TAG**

Play in waist deep water. "It" tries to tag other players by hitting them with a soft rubber ball. If "it" misses, the player at whom he threw the ball tosses the ball back to him. Establish boundaries so that distances will not be great.

##### **DUCK TAG**

Play in waist deep water. A player is safe from being tagged if he ducks completely underwater for a second or two when "it" approaches.

##### **TOUCH**

Play in chest deep water. Divide den into two teams and line them up in parallel lines five to six feet apart. The leader calls out the name of an object that is an equal distance from both teams—diving board, rubber mat, edge of pool, a ball, All players rush to touch the object and return. The team returning first scores one point.

##### **FLOAT TAG**

This is a game for non-swimmers who are just learning to float. "It" tries to tag the others, but they are safe so long as they are in any floating position.

##### **BALLOON RELAY**

Divide into two teams. Give each team a balloon in shoulder deep water. On signal, the first boy on each team starts walking or swimming, butting the balloon with his head. He may not touch it with his hands. At a turning point, he walks or swims back and the next team member repeats the action. Continue until all have raced.

##### **PENNY HUNT**

Play in waist deep water so that boys will have to duck under to retrieve pennies. Be sure to count pennies beforehand, so you will know when all have been retrieved. This may help lessen fear putting one's head under water.

### Games for good swimmers

##### **SWIMMING POM POM PULLAWAY**

'It' is in the center of the pool in chest deep water. Other players are on one side of pool. When "It" calls, "Pom pom pull away," the others try to swim across the pool without being tagged by "it". Players who are tagged join 'it' for the next attempted crossing by the others. Last one caught becomes "it" for the next game.

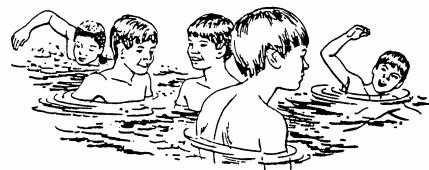

##### **RESCUE RELAY**

Divide group into two teams. First player on each team stays on shore while the others go into shoulder deep water, facing the shore or pool edge. On signal, the first player grabs a towel and runs and swims to his teammates. He throws an end of the towel to a teammate who grabs it and is pulled to shore. The rescued boy then runs back into the water and rescues another. First team finished wins.

# FIN FUN

## July 2004

### Aquanaut

#### WATER BASKETBALL

For baskets, place inner tubes or life buoys in the water at both sides of deep-water area. Divide players into equal teams. Use a beach ball or basketball size rubber ball. Play usual basketball rules, except that a player dribbles by tapping the ball in the water. Players in this game should be good swimmers.

#### PREVENTING ACCIDENTAL HOME POOL DROWNINGS

##### 1. FORMULATE AN EMERGENCY PLAN

Base the plan on your home surrounding and then practice various emergency situations.

##### 2. PROVIDE ADEQUATE FENCING WITH A LATCHING GATE AROUND THE POOL AREA

Fence should be at least 5ft. high with vertical or solid segments close enough so that children cannot climb over it.

##### 3. THE GATE SHOULD BE SECURELY LOCKED WHEN POOL IS NOT IN USE!

##### 4. AN ALARM SYSTEM IN THE POOL SHOULD BE CONSIDERED

Alarm sounds when someone falls in—remember to check the batteries on a regular basis.

##### 5. TAKE A COURSE IN CPR AND WORK ON IMPROVING YOUR AQUATIC SKILLS

##### 6. RESCUE EQUIPMENT SHOULD BE VISIBLY DISPLAYED ON THE POOL DECK

Keep basic equipment in good condition

##### 7. POST EMERGENCY INSTRUCTIONS AND PHONE NUMBERS NEAR THE TELEPHONE

Be prepared when calling 911: Who? When? Where? How?

Have victim's medical records handy if possible

Know your family physician's name and phone number

Post parent's work addresses and phone numbers

##### 8. APPOINT AN EMERGENCY COVER-DOWN PERSON TO CARE FOR OTHER CHILDREN (two deep leadership)

##### 9. REVIEW YOUR LIABILITY INSURANCE

#### ORGANIZATIONS THAT CAN HELP WITH TEACHING OR FIELD TRIPS POSSIBILITIES

YMCA

RED CROSS

AMERICAN HEART ASSOCIATION

EMT/ FIRE DEPARTMENT (*explain that you would like someone to talk to the boys about water safety*)

DISTRICT HEALTH AND SAFETY COMMITTEE (*most committees have one or two people involved with the Safety Afloat program*)

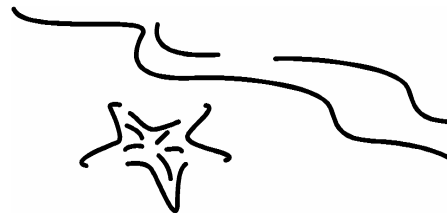
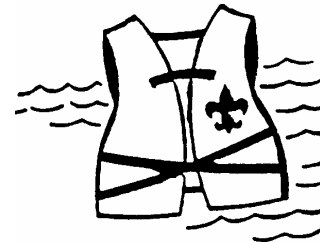

# FIN FUN

## July 2004

### Aquanaut

#### A TRUE BOATMAN

A true boatman never leaves shore in a small boat without an armload of equipment and a head full of important facts. The word TRUE has important meanings. Learn each meaning and boating will be an enjoyable activity.

- T** Trim the boat. Do not carry more in the boat than that which makes it safe for the riders. To find the number of passengers, multiply length of boat in feet, by the width in feet and divide by 15. This will tell you how many people can safely ride in your boat. For a canoe a six foot freeboard, multiply distance between water and the top of the gunwale at its lowest point.
- R** Remember equipment. Shown here. A must to carry. Remember the needs for each passenger. Have a check list and check it before leaving the pier.
- U** Understand the rules. Learn them and instruct others. These small crafts must obey some of the same rules as the largest powerboats.
- E** Easy does it. A steady pace, a straight line, conserve energy, avoid bad weather, never clown or stand up, wear your LIFE JACKET, stay with an overturned boat, will make you a TRUE boatman. The U.S. Coast Guard has a saying that's useful for all: "MAKE SURE. MAKE SHORE." You may also write to the Coast Guard and request a pamphlet on safety, rules, and equipment

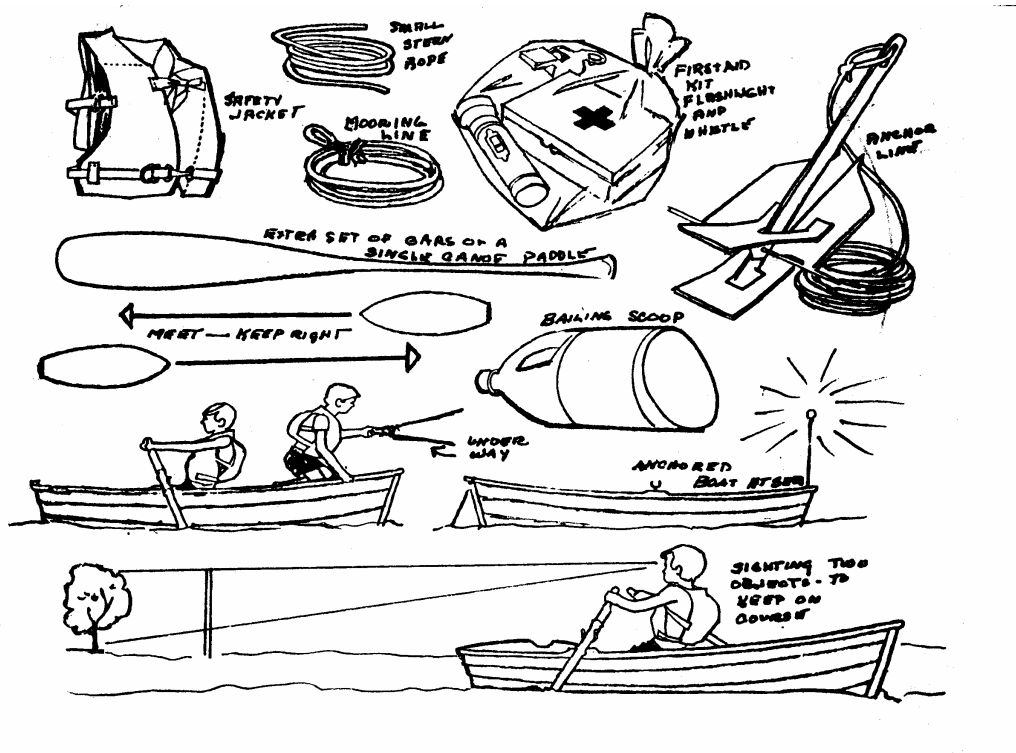

# FIN FUN

## July 2004

### Geologist



#### LET'S GO ROCK COLLECTING

**Clothes:** type of clothes you would wear hiking or hunting.

**Collecting bag:** a knapsack with pockets is ideal. Lunch size paper bags can be used to put individual specimens in. Also take newspaper to wrap rocks in first.

**Field Notebooks and labels:** Give each specimen a number and label it before you wrap it. In a small pocket notebook record: Name/ Location/ Date/ collector

**Big and little hammers:** An 8 x 10 pound sledgehammer and a 1 ½ to 2 pound hammer.  
**Chisels:** One or more steel chisels (Wood chisels chip and dull too quickly)  
**Goggles and face shields:** To protect face and eyes while hammering at rocks  
**Magnifiers:** Hand lens or pocket magnifier  
**First Aid Kit**  
**Compass**

#### REMEMBER:

- ◆ Ask for permission before going on private property
- ◆ Don't meddle with tools, machinery or domestic animals
- ◆ Leave gates as you found them
- ◆ Stay on roads, don't walk or drive over growing crops
- ◆ Take only what you will use for yourself or trading, leave something for others after you.
- ◆ Be courteous and considerate of the rights of others
- ◆ Listen to the leader.

#### ROSE ROCK TIE SLIDE

**Materials:** Rose rock 1 ½" diameter (Can be purchased at MJ Designs)  
Plastic plumbing pipe ½" x ½"  
Epoxy, clear acrylic spray

#### DIRECTIONS

Clean the rock with water and a small soft brush to bring out the petals of the rose. Epoxy the rock to the piece of PVC pipe and allow to dry completely. Coat the rock with several coats of acrylic spray.



# FIN FUN

## July 2004

### Geologist

#### VOLCANOES

By Barb Stephens

Read the definitions, then label the diagram below.

**ash cloud** - the cloud of ash that forms in the air after some volcanic eruptions

**conduit** - a passage through which magma (molten rock) flows in a volcano

**crust** - the Earth's outermost, rocky layer

**lava** - molten rock; usually comes out of erupting volcanoes

**magma chamber** - contains magma (molten rock) deep within the Earth's crust

**side vent** - a vent in the side of a volcano

**vent** - an opening in the Earth's surface through which volcanic materials erupt

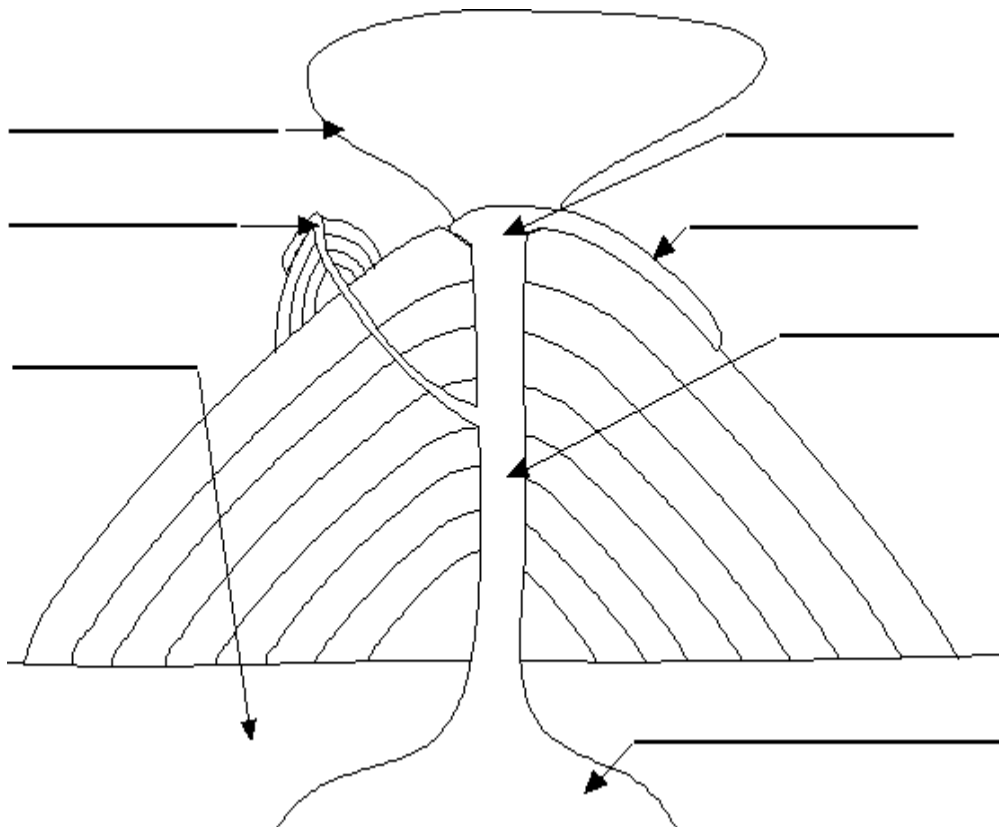

# **FIN FUN**

## **July 2004**

### **Tigers - Safety in the Sun/ Fun in the Water**

#### **Family Activity**

*Remember to SLIP, SLOP, SLAP and WRAP!*

*SLIP on a shirt. SLOP on sunscreen. SLAP on a hat. WRAP on sunglasses*

**As a family were every you choose to go for water fun. Discuss the rules for each of those locations.**

#### **BEACH SAFETY**

- ◆ Protect your skin: Sunlight contains two kinds of UV rays -- UVA increases the risk of skin cancer, skin aging, and other skin diseases. UVB causes sunburn and can lead to skin cancer. Limit the amount of direct sunlight you receive between 10:00 a.m. and 4:00 p.m. and wear a sunscreen with a sun protection factor containing a high rating such as 15.
- ◆ Drink plenty of water regularly and often even if you do not feel thirsty. Your body needs water to keep cool. Avoid drinks with alcohol or caffeine in them. They can make you feel good briefly but make the heat's effects on your body worse. This is especially true with beer, which dehydrates the body.
- ◆ Watch for signs of heat stroke: Heat stroke is life threatening. The victim's temperature control system, which produces sweating to cool the body, stops working. The body temperature can rise so high that brain damage and death may result if the body is not cooled quickly. Signals include hot, red, and dry skin; changes in consciousness, rapid, weak pulse, and rapid, shallow breathing. Call 9-1-1 or your local EMS number. Move the person to a cooler place. Quickly cool the body by wrapping wet sheets around the body and fan it. If you have ice packs or cold packs, place them on each of the victim's wrists and ankles, in the armpits and on the neck to cool the large blood vessels. Watch for signals of breathing problems and make sure the airway is clear. Keep the person lying down.
- ◆ Wear eye protection: Sunglasses are like sunscreen for your eyes and protect against damage that can occur from UV rays. Be sure to wear sunglasses with labels that indicate that they absorb at least 90 percent of UV sunlight.
- ◆ Wear foot protection: Many times, people's feet can get burned from the sand or cut from glass in the sand.

**FIN FUN**  
**July 2004**

**Tigers - Safety in the Sun/ Fun in the Water**  
**Family Activity**

# FIN FUN

## July 2004

### HOME POOLS

- ◆ Learn to swim. The best thing anyone can do to stay safe in and around the water is to learn to swim--this includes adults and children. The American Red Cross has swimming courses for people of any age and swimming ability. To enroll in a course to learn or improve your ability to swim, contact your local Red Cross chapter.
- ◆ Never leave a child unobserved around water. Your eyes must be on the child at all times. Adult supervision is recommended.
- ◆ Install a phone by the pool or keep a cordless phone nearby so that you can call 9-1-1 in an emergency.
- ◆ Learn Red Cross CPR and insist that babysitters, grandparents, and others who care for your child know CPR.
- ◆ Post CPR instructions and 9-1-1 or your local emergency number in the pool area.
- ◆ Enclose the pool completely with a self-locking, self-closing fence with vertical bars. Openings in the fence should be no more than four inches wide. If the house is part of the barrier, the doors leading from the house to the pool should remain locked and be protected with an alarm that produces sounds when the door is unexpectedly opened.
- ◆ Never leave furniture near the fence that would enable a child to climb over the fence.
- ◆ Always keep basic lifesaving equipment by the pool and know how to use it. Pole, rope, and personal flotation devices (PFDs) are recommended.
- ◆ Keep toys away from the pool when it is not in use. Toys can attract young children into the pool.
- ◆ Pool covers should always be completely removed prior to pool use.
- ◆ To learn more about home pool safety, you can purchase the video *It Only Takes a Minute* from your local Red Cross chapter.
- ◆ If a child is missing, check the pool first. Go to the edge of the pool and scan the entire pool, bottom, and surface, as well as the surrounding pool area.

### SAFETY IN, ON AND AROUND THE WATER

- ◆ Maintain constant supervision. Watch children around any water environment (pool, stream, lake, tub, toilet, and bucket of water), no matter what skills your child has acquired and no matter how shallow the water.
- ◆ Don't rely on substitutes. The use of flotation devices and inflatable toys cannot replace parental supervision. Such devices could suddenly shift position, lose air, or slip out from underneath, leaving the child in a dangerous situation.
- ◆ Enroll children in a water safety course or Learn to Swim program. Your decision to provide your child with an early aquatic experience is a gift that will have infinite rewards. These courses encourage safe practices. You can also purchase a *Community Water Safety* manual at your local Red Cross.
- ◆ Parents should take a CPR course. Knowing these skills can be important around the water and you will expand your capabilities in providing care for your child. You can contact your local Red Cross to enroll in a CPR for Infants and Child course.

# **FIN FUN**

## **July 2004**

### **Tigers - Safety in the Sun/ Fun in the Water**

#### **Family Activity**

##### **LAKES AND RIVERS**

- ◆ Learn to swim. The best thing anyone can do to stay safe in and around the water is to learn to swim--this includes adults and children. The American Red Cross has swimming courses for people of any age and swimming ability. To enroll in swim course, contact your local Red Cross chapter.
- ◆ Select a supervised area. A trained lifeguard who can help in an emergency is the best safety factor. Even good swimmers can have an unexpected medical emergency in the water. Never swim alone.
- ◆ Select an area that is clean and well maintained. A clean bathhouse, clean restrooms, and a litter-free environment show the management's concern for your health and safety.
- ◆ Select an area that has good water quality and safe natural conditions. Murky water, hidden underwater objects, unexpected drop-offs, and aquatic plant life are hazards. Water pollution can cause health problems for swimmers. Strong tides, big waves, and currents can turn an event that began as fun into a tragedy.
- ◆ Make sure the water is deep enough before entering headfirst. Too many swimmers are seriously injured every year by entering headfirst into water that is too shallow. A feet first entry is much safer than diving.
- ◆ Be sure rafts and docks are in good condition. A well-run open-water facility maintains its rafts and docks in good condition, with no loose boards or exposed nails. Never swim under a raft or dock. Always look before jumping off a dock or raft to be sure no one is in the way.
- ◆ Avoid drainage ditches and arroyos. Drainage ditches and arroyos for water run-off are not good places for swimming or playing in the water. After heavy rains, they can quickly change into raging rivers that can easily take a human life. Even the strongest swimmers are no match for the power of the water. Fast water and debris in the current make ditches and arroyos very dangerous.

# FIN FUN

## July 2004

### Tigers - Safety in the Sun/ Fun in the Water

#### Family Activity

##### OCEAN SAFETY

- ◆ Learn to swim. The best thing anyone can do to stay safe in and around the water is to learn to swim--this includes adults and children. The American Red Cross has swimming courses for people of any age and swimming ability. Contact your local Red Cross chapter for information on courses.
- ◆ Stay within the designated swimming area, ideally within the visibility of a lifeguard.
- ◆ Never swim alone.
- ◆ Check the surf conditions before you enter the water. Check to see if a warning flag is up or check with a lifeguard for water conditions, beach conditions, or any potential hazards.
- ◆ Stay away from piers, pilings, and diving platforms when in the water.
- ◆ Keep a lookout for aquatic life. Water plants and animals may be dangerous. Avoid patches of plants. Leave animals alone.
- ◆ Make sure you always have enough energy to swim back to shore.
- ◆ Don't try to swim against a current if caught in one. Swim gradually out of the current, by swimming across it.

##### WATER PARKS

- ◆ Learn to swim. The best thing anyone can do to stay safe in and around the water is to learn to swim--this includes adults and children. The American Red Cross has swimming courses for people of any age and swimming ability. To enroll in a swim course, contact your local Red Cross chapter.
- ◆ Be sure the area is well supervised by lifeguards before you or others in your group enter the water.
- ◆ Read all posted signs. Follow the rules and directions given by lifeguards. Ask questions if you are not sure about a correct procedure.
- ◆ When you go from one attraction to another, note that the water depth may be different and that the attraction should be used in a different way.
- ◆ Before you start down a water slide, get in the correct position -- face up and feet first.
- ◆ Some facilities provide life jackets at no charge. If you cannot swim, wear a Coast Guard-approved life jacket. Check others in your group as well.

FROM - [www.redcross.org](http://www.redcross.org)

# FIN FUN

## July 2004

### Tigers - Safety in the Sun/ Fun in the Water

#### Den Activity

##### **BUCKET BRIGADE RELAY**

Play outdoors. Divide den into two teams. Give each team two pails, one filled with water and one empty. Place the empty bucket some distance from each team. On signal, the first player in each team carries the full pail to the empty one and pours the water into it, and then returns to the next person in line with the full pail. The next boy repeats the same actions, and so on until all have carried the water. This is not a speed contest. The winning team is the one that has the most water in one pail when all the members have finished.

##### **GO FISH**

Trace six to ten fish on construction paper and cut out. Attach a paper clip to the top of each fish. Draw eyes, mouth, and fins with a marker. Tie a magnet to a 15-foot length of string. Tie the other end of the string to a stick. Place the fish in a box. (An old fish tank is even more fun.) To make the game harder, put the fish in a metal coffee can (the magnet sticks to the sides and the fish drop off). See how many fish you can catch by having the magnet catch on the fish paper clips. Whoever catches the most fish in a given time limit wins.

##### **EEL RACE**

Choose teams of four. Everyone gets down on hands and knees and the teams line up behind their leader. The second member grasps the leader by his ankles, and the player behind him grabs hold of his ankles, etc. When the starting signal is given the eel's race across the room, turn around and return to the starting point without breaking the hand and ankle hold.

##### **STEAL THE TURTLE**

Play in Waist deep water. Divide boys into two equal teams that line up facing each other 20 feet apart. Each team member is given a number. A leader tosses a large rubber ball in the middle of the play area and calls out a number. The opposing players with that number race for the ball. The player who gets it and returns to his place without being tagged by the opposing player scores one point. When both boys are back at their places, the leader calls out another number. For a real scramble, call all numbers at once.

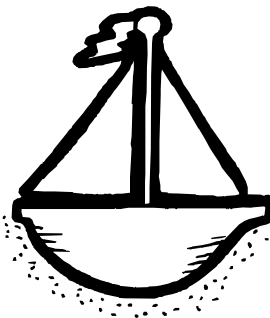

##### **IN THE SEA**

Arrange partners around in a circle. Have the leader, call out "in the sea" when this is done all players are to jump into the circle. When he calls "on the beach" all player then jump back out of the circle. Anyone making a mistake is out of the game. The last player is the winner.

##### **GRAB THE FISH TAIL**

Boys and their partners line up in a single file, holding each other around the waist. The first boy is the fish's head; the last person is the tail. When all are ready the leader says, "Go." The head tries to catch the tail. The tail tries to avoid being caught. The boys must keep hold on each other. The longer you can make this fish, the more fun you will have!

# FIN FUN

## July 2004

### Tigers - Safety in the Sun/ Fun in the Water

#### Go See It

- ◆ Go to a water park
- ◆ Go to a pool
- ◆ Visit a Lake
- ◆ Visit a fish farm
- ◆ Dallas Zoo & Aquarium at Fair Park
- ◆ The Dallas World Aquarium & Zoological Garden
- ◆ Texas Discovery Gardens | Dallas
- ◆ Dallas Arboretum & Botanical Society
- ◆ Fort Worth Zoo
- ◆ Fort Worth Water Gardens

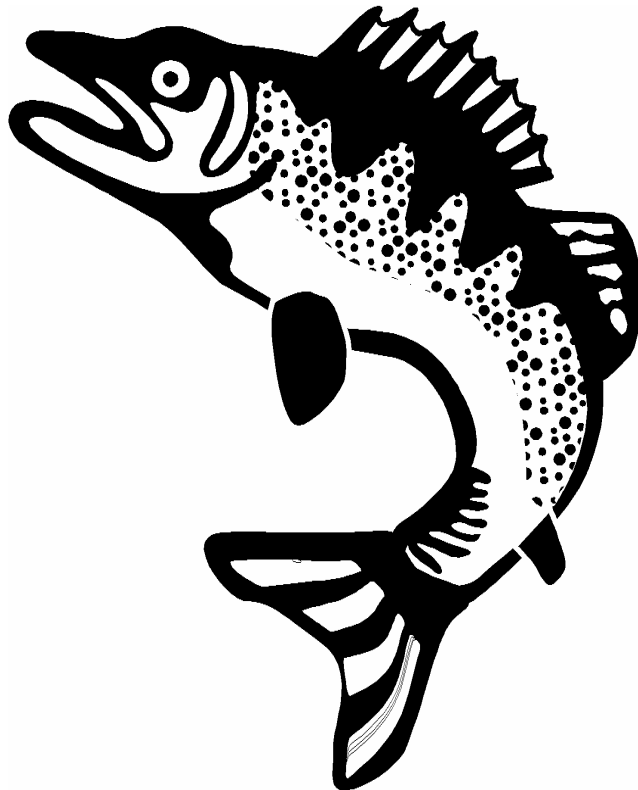



# FIN FUN

## July 2004

### Cubmaster Corner - Delivering Cubmaster Minutes

#### The Making of Interesting Cubmaster Minutes

- ◆ It can have music and/ or props.
- ◆ It should have strong appeal for youth.
- ◆ It should offer variety.
- ◆ It should instill the deeper values of Scouting.
- ◆ It can be Fun or Serious, but it should be something the boys will remember.
- ◆ It should contribute toward the development and maintenance of strong family relationships.
- ◆ It should be simple, within the capability and interests of both Scouting Members and Parents.
- ◆ It should be SHORT thus the title Cubmaster Minute!



*Below you will find a few Minute ideas:*

#### **PARABLE OF THE PAUPER**

*Use Popcorn as your prop*

*(You can also have small bags of popcorn to give to the boys at the end of the meeting)*

Behold at the time of the harvest the ears of corn did bring forth kernels, which were dried and prepared for the popper's hand.

And the popper did take the kernels, all of which appeared alike unto him, and did apply the oil and the heat.

And it came to pass when the heat was on, some did explode with promise and did magnify themselves, yea, even a hundred fold.

And some did burst forth with whiteness, which did both gladden the eye of the beholder and the taste of the popper.

And likewise, some others did pop, but not too much.

But lo, there were some that just laid there and even though the popper's heat was alike unto all, they did bask in the warmth of the oil, and kept everything they had for themselves.

And so it came to pass, that those which had given of themselves, did bring joy and delight to many munchers; but those which kept of the warmth and did not burst forth, were fit only to be cast out, and were thought of with hardness and disgust.

And thus, we see that in the beginning all appear alike, but when the heat is on, some come forth and give their all, while others fail to pop and become as chaff on the threshing floor, to be discarded and forgotten.

# FIN FUN

## July 2004

### Cubmaster Corner - Delivering Cubmaster Minutes

#### WORDS OF WISDOM

President John Kennedy said that intelligence and skill can function best when the body is healthy and strong. Hardy spirits are in strong bodies.

God has given us two hands--one to receive with and one to give with.

It's nice to be important but it's more important to be nice.



It isn't necessary to blow out the other fellow's candle in order to make yours burn more brightly.

Don't dodge difficulties: meet them, greet them, beat them.

Great things are possible from insignificant beginnings.

Let's remember it is not where we start from that counts, but what we do along the way. Follow the

Cub Scout motto: DO YOUR BEST.

A Cub Scout does his best even when no one is looking. This is the test of whether or not you are a good Cub Scout. One of the hardest things for anyone to do is to stick to what he knows is right while his friends are coaxing him or his enemies are threatening him to do the opposite. A Cub Scout does his best.

When you join the Cub Scouts, you are no longer just an ordinary boy. You are a Cub Scout. In following the Cub Scout Promise and the Law of the Pack, you are setting an example for others to follow.

Our motto is Do YOUR BEST. Does that mean you can't improve? The answer is no. The biggest room in the world is the room for improvement.

Every Cub Scout is a BUILDER: he builds one of the most important things in the world--his body.

God grant that not only love of liberty but a thorough knowledge of the rights of man may pervade all the nations of the earth, so that a philosopher may set his feet anywhere on its surface and say "THIS IS MY COUNTRY "

Work while you work, play while you play, one thing at a time, that is the way. All that you do, do with all your might. Things done halfway are not done right.

#### BADGE, BOOK and CANDLE

Place a Cub Scout badge, a Cub Scout handbook, and a lighted candle on a table.

**Cubmaster:** There are all kinds of badges, such as a police officer's badge. Cub Scouts, these three things in front of me have been significant in Cub Scouting since it began in 1930. This badge is a symbol of Cub Scouting all over America. Also, many books are important to Cub Scouting and to Cub Scouts. The Tiger Cub, Wolf, Bear, and Webelos Scout handbooks help us learn new skills. The books of our faith are other important books that guide our daily lives and help us determine right from wrong. The candle is a symbol of the light of Scouting that penetrates the darkness of hate, prejudice, and distrust. This light must be kept burning in the heart of every Scout, now and as he grows into an adult.

# SCOUTING THE MIDWAY

## August 2004

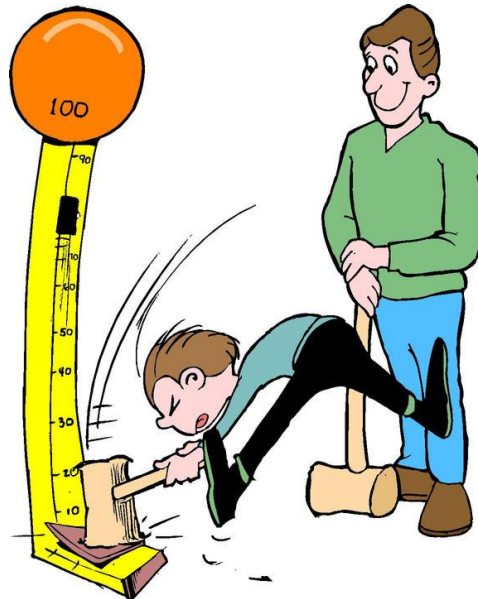

Step right up folks....for a chance at some fun! This month is full of fun and games. Each den will create a midway game to run at the Pack Midway. How about a ring toss, a beanbag throw, a coin toss, a ball throw, or a card throw? Get those creative juices flowing. The boys can design and build the games at their den meetings, and then run their game at the Pack Midway, so everyone gets in on the fun. What's a midway without prizes? Make sure you have prizes for all age groups. And don't forget the popcorn!

Cub Scout Theme .....	03
Webelos – Naturalist.....	15
Webelos – Forester .....	17
Tigers - Collecting and Other Hobbies .....	21
Cubmaster Corner - Involving the Family .....	23

# SCOUTING THE MIDWAY

## August 2004

**This Moment**  
**Circle Ten Pow Wow**  
Author unknown

I may never see  
tomorrow; there's no  
written guarantee,  
And things that  
happened yesterday  
belong to history.  
I cannot predict the  
future, and I cannot  
change the past,  
I have just the present  
moment; I must treat  
it as my last.  
I must use this  
moment wisely for it  
soon will pass away,  
And be lost to me forever as a part of yesterday.  
I must exercise compassion, help the fallen to their feet,  
Be a friend unto the friendless, make an empty life complete.  
I must make this moment precious for it will not come again,  
And I can never be content with things that might have been.  
Kind word I fail to say this day may never be unsaid,  
For I know not how short may be the path that lies ahead.



The unkind things I do today may never be undone,  
And friendships that I fail to win may nevermore be won.  
I may not have another chance on bended knee to pray,  
And thank my God with humble heart for giving me this day.  
I may never see tomorrow, but this moment is my own.  
It's mine to use or cast aside; the choice is mine, alone.  
I have just this precious moment in the sunlight of today,  
Where the dawning of tomorrow meets the dusk of yesterday.

# SCOUTING THE MIDWAY

## August 2004

### Gathering Activities

#### MIDWAY WORDS

*On the Midway the workers had a different language that they spoke with each other. Can you match the correct word with the definition?*

- |   |            |
|---|------------|
| 1. Any midway game operator.  | BEEF       |
| 2. A complaint from a customer.                                     | BLOW DOWN  |
| 3. Lose money   | GRAB JOINT |
| 4. Tents or rides that are leveled to the ground by a windstorm.    | MIDWAY     |
| 5. A rest room.   | PARADE     |
| 6. An eating concession   | SINGLE – O |
| 7. Poisonous snake used on a midway show.                           | TROUPER    |
| 8. Location where all the concessions, rides and shows are located. | AGENT      |
| 9. A fortune telling booth on a midway.                             | BLOW       |
| 10. Used to announce the arrival of the circus to town.             | DONIKER    |
| 11. Any show that plays the midway.                                 | HOT SNAKE  |
| 12. Single attraction.  | MITT CAMP  |
| 13. Cheap prizes.   | SIDESHOW   |
| 14. A person who has been with a traveling midway for one year.     | SLUM       |

Answers: 1.Agent, 2.Beef, 3.Blow, 4.Blow Down, 5.Doniker, 6.Grab Joint, 7.Hot Snake, 8.Midway, 9.Mitt Camp, 10.Parade, 11.Sideshow, 12.Single-O, 13. Slum, 14.Trouper

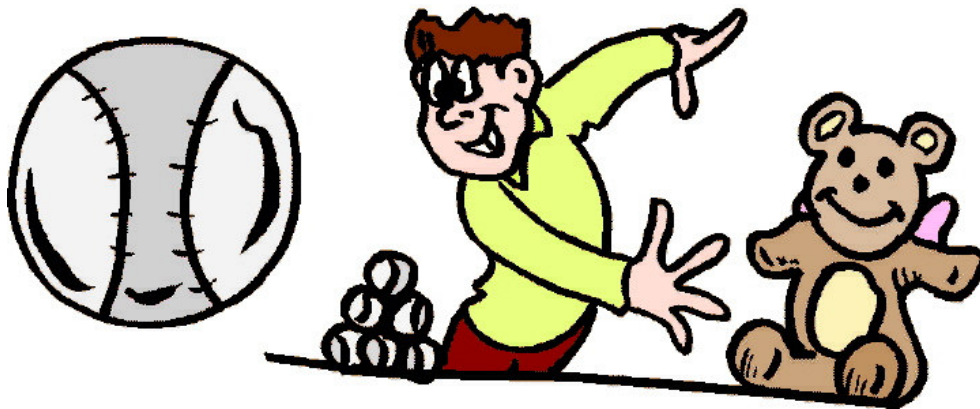

# SCOUTING THE MIDWAY

## August 2004

### Openings

#### BALLOON POP PROMISE

*PERSONNEL: 7 Cub Scouts.*

*EQUIPMENT: 7 balloons to be popped, part of the Cub Scout Promise on a note inside each.*

CUB 1: Pop balloon and read: I (name) PROMISE

CUB 2: Pop balloon and read: To do my Best

CUB 3: Pop balloon and read: To do my Duty to God

CUB 4: Pop balloon and read: And My Country

CUB 5: Pop balloon and read: To help other People and

CUB 6: Pop balloon and read: To Obey the Law of the Pack

CUB 7: The Cub Scout Promise reminds us to be the Best that we can be, to be Proud to be an American.



#### SHOW TIME

TV ANNOUNCER: (with microphone) Welcome ladies and gentlemen, boys, and girls, to one of the greatest family entertainment nights of the year. This is Show Biz Pack meeting night!

SIGN HOLDER: Cub holding card saying "applause" walks past the front row of seats showing his can. He can be wearing ear phones as if he is getting orders from a control booth.

TV ANNOUNCER: We have for you a preview of tonight's attractions. Tonight for your pleasure we will have songs!

SINGERS: Small group of wildly dressed Cubs with instruments can come in singing words of a pop song.

SIGN HOLDER: He follows close behind with a sign that says 'yea'.

TV ANNOUNCER: We have for you games!

ATHLETES: A small group of Cubs come in dressed in team uniforms with balls and giving each other pep talks, sign holder; He follows close behind with a Sign saying "HOORAY."

TV ANNOUNCER: Of course we will have a little business to discuss.

SIGN HOLDER: Comes close to announcer with a sign that says "BOO".

TV ANNOUNCER: And we will have a lot of fun!

SIGN HOLDER: Comes close to announcer with a sign, that says "OH BOY".

TV ANNOUNCER: But before we get on with the show, lets all rise and say the Pledge of allegiance to the Flag.

TV ANNOUNCER: (Like introducing Johnny Carson- swing a pretend golf club) Now hee-  
-aars the Cubmaster.

SIGN HOLDER: Shows the "applause" sign again.

# SCOUTING THE MIDWAY

## August 2004

### Den Activities

#### MIDWAY IDEAS TO DO AND MAKE

##### KIDDIE PUTTER

16-foot golf run way is perfect for practicing a putt. They try putting the golf ball through the mouth of a friendly clown.

##### SHARK ATTACK

Stand on a wooden surfboard and slingshot fake fish into the mouth of Jaws.

##### GOLF CHALLENGE

Test your golf accuracy by chipping Velcro golf balls to the freestanding 8' X 8' green.

##### PIN THE TAIL ON THE DONKEY

An all time classic, try to pin the Velcro tail on the donkey. Closest player to the butt, wins.

##### CARNIVAL GAMES

Bring tradition to your next event with midway carnival games. Tic-tac toe, duck ponds, bean bag toss.

##### SPIN ART

Drop dabs of nontoxic colorful paint on Frisbees, shirts or index card and then they are spun into action creating a colorful one of a kind design.

##### SAND/CANDY ART

Create their own arrangement of bright sand colors in one of many plastic bottles designs. Take it one step further and use tart candy instead of sand and it now becomes a design that the kids can eat.

##### WET SPONGE TOSS

Set up a large piece of cardboard on which is painted head and body. Leave a hole for the face. A boy stands behind the cardboard and pokes his head through the hole as a target. You can use a decorated balloon instead, but it isn't as much fun. Players toss wet sponges at the target; three tosses per participant.



##### DARTS

Boys toss darts to burst balloons mounted on a board. Observe safety rules.

##### PENNY TOSS

Players try to toss coins into cereal bowls floating in a tub (or dishpan) of water.

##### KNOCK'EM OVER

Place large juice cans or milk cartons in a cluster. Participant have three shots to upset them with a tennis or rubber ball tossed from a distance.

# SCOUTING THE MIDWAY

## August 2004

### Den Activities

#### MIDWAY IDEAS TO DO AND MAKE continued

##### **DOUSE THE CANDLE**

Players squirt water from a water pistol, or through a drinking straw, in an attempt to put out the flame of a safely mounted candle.

##### **FISH POND**

Fill a large box or barrel with paper fish onto which are attached large safety pins. Participants try to hook fish with a fishing pole. Not all fish are worth a prize. Print the value of prize winners on them.

##### **GUESS HOW MANY**

Participants write their estimates of the number of beans in a jar on a slip of paper and include their names. Award prizes to winners at the end of the evening

##### **DUCK POND**

participants are blind-folded and attempt to pick 3 of the same color duck. This is a nice alternative to the regular duck pond game - NO WATER!

##### **PING PONG TOSS**

Line up bowls on the ground and had the participants try to get the balls in the bowls.

##### **Outdoor Carnival Games:**

- Knock down the cans
- Bean bag toss
- Drop the clothespin in a bottle
- Ring toss
- Bob for apples
- Bushel toss

##### **Contests:**

- pie eating contest  
(mini pies available from the snack section of most supermarkets)
- juggling contest
- sack race
- Catch the water balloon
- watermelon eating contest
- seed spitting contest

##### **Other Activities:**

- Music
- Arm wrestling
- Pet parade
- Cake walk
- Face painting
- Raffle (one for kids and one for adults)





# SCOUTING THE MIDWAY

## August 2004

### Songs

#### **BOOGALOO**

(this song is best sung while everyone is standing in a circle stomping their feet... and VERY LOUD!!)

(leader) Let me see you boogaloo!

(everyone) SAY WHAT? (or: WHAT'S THAT YOU SAY?)

(leader) Let me see you boogaloo!

(everyone) SAY WHAT? (or: WHAT'S THAT YOU SAY?)

(leader) Let me see you boogaloo...

(everyone) We go: booga, booga, boogaloo! Booga, booga, boogaloo!

#### Actions:

Throughout the verse, everyone links arms with their neighbors and stomps

their feet as hard as possible

Say what?: everyone leans in to the circle

Booga, booga, boogaloo: do a hokey-pokey sort of dance, turning around on

the spot

#### Other Verses and Their Actions:

Crocodile: make a set of jaws with your arms, and chomp

Elephant: one arm up to your face as a trunk

Brush your teeth: one finger used as a toothbrush

Platypus: squeeze your lips between your fingers and make raspberry sounds

Porcupine: shake fingers out in front of your body stiffly, as if you were

feeling the back of a porcupine!

#### **GIVE MY REGARDS TO THE MIDWAY**

*Tune: Give My Regards To Broadway*

Give my regards to the Midway,  
Remember me at the dunking booth,  
Tell all the folks at the Penny arcade  
That I will soon be there,  
Whisper of how I'm yearning  
To mingle with the old time friends,  
Give my regards to old Midway  
And tell them I'll be coming back soon.

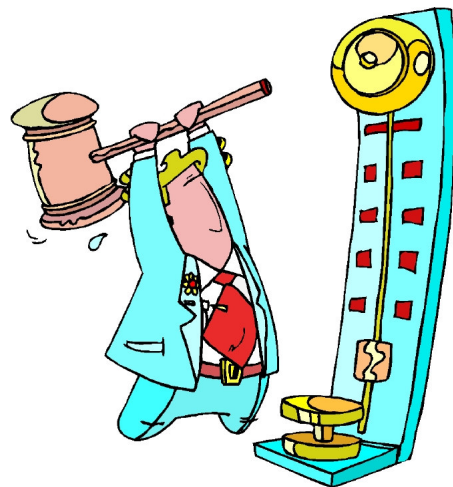

# SCOUTING THE MIDWAY

## August 2004

### Skits

#### GAME SHOW

The skit starts out with a couple of scouts asking for some volunteers from the audience (parents will do JUST fine...evil grin).

The volunteers are then removed from the room by one of the scouts in charge of the 'Game Show' (thank you Vanna...)

After the volunteers have been removed, the 'Game' is set up. Two tables (the folding type work VERY well) are covered with sleeping bags and balls of various descriptions are placed under buckets on these tables, the catch is that in between the two tables a person (another scout perhaps) is kneeling with his head under a bucket to resemble the other buckets (of course this is well hidden with sleeping bags, or sheets or what ever you have handy) The tables are then moved close together to further hide the fact that there is anyone under the table, and don't forget to cover the front of the table so that the participant, or victim as it were, cannot see under the tables.



Bring in the first contestant...

It is then that the 'Game' is described to the contestant. He/she is to make his/her way down the line of buckets picking up each bucket and naming the ball under the bucket. Give some time record to be beaten. Then as they make their way down the line and eventually pick up the bucket off of the table under which the scout is hiding, the scout should yell/scream etc. to further the shock value.

Bring in the next contestant...etc

This skit is generally really effective and is good for a few laughs.

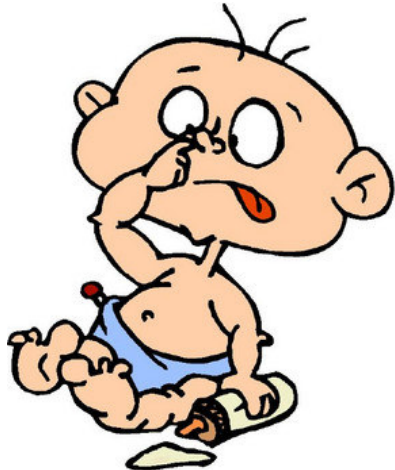

#### THE LITTLE GREEN BALL

This one is so old, but it appeals to the grossness that boys love! First scout comes on and says 'Oh no I've lost it' He then starts to search around on the floor. Second scout comes in and asks what he is looking for. First scout replies that he has lost his little green ball. Both scouts continue searching the floor. Several more scouts come on and are told about the lost little green ball. Even members of the audience can be persuaded to join in the search. After enough time has been dragged out, the first scout, sticks a finger up his nose and says "Don't worry I will have to make another one" YUK!!!!

# SCOUTING THE MIDWAY

## August 2004

### Advancement Ceremonies

#### SIDESHOW ANIMALS

*Have various "animal tracks" available as each of the following are discussed.*

Cubmaster: (In a secretive manner). We are gathered tonight to study all the details of the scene of the crime. The first animal we need to identify has the following characteristics: It is striped, orange and black, stalks prey, belongs to the cat family. From all the above details I believe we are describing the Tiger family.

The next animal track we found was a fairly fresh one. The items known are it is red in color, spotted, has a short stubby tail, and belongs to the Lynx family. Could it be a Bobcat that was spotted hanging around here:

The next track was harder to track as it belongs to the Dog family. It loves to eat game and livestock, but especially loves to howl. It is more commonly known as the Wolf. This track was easy. It is larger in size than the other tracks. It is a mammal with long shaggy hair, and loves to eat fruit and insects. Our Bears are easy to spot.

This was the hardest of all the tracks. It has been here the longest so it was harder to identify. It made deeper grooves like it had more hanging on it. The identifying marks that made it easy to finally identify were its love of candy, sodas and junk food.. And the evidence that it is tall and gangly. Of course, it could only be a Webelos. It greatly relieves my mind that all tracks have been identified and classified into groups. Everyone loves to solve a mystery.

#### GAMES ADVANCEMENT

Note that this and other ceremonies should be reviewed and modified to suit the specific awards being giving at the meeting. This ceremony is written so that any particular award can be used or omitted without impacting the whole of the ceremony.

Cubmaster: There are a lot of computer games on the market today, and while I was surfing the Internet the other day, I found a really good one that I want to share with you. It's called "Advancement."

Now unlike many of the games out there, this one doesn't have all the wiz-bang violence and high-speed flying and diving; it doesn't involve racking up billions of points on the scoreboard; and it can only be played by a very select group of people—Cub Scouts. This is a "game" that checks out your ability to "Do Your Best."

And as in any game, the player must first learn the rules of the game. In this program, the players start in any grade, from 2nd through 5th. They learn the rules, such as the Cub Scout Promise and the Law of the Pack; what the different signs and signals mean in the activity, like the handshake and Scout sign; and special phrases and messages used during play, like Webelos and "Do Your Best." Once they've learned these basic rules, they are ready to begin the game in earnest. And once the player has learned the rules, the computer places an icon on the screen that shows the player has completed the "rules" phase—the icon looks like this.

[Cubmaster holds up a Bobcat badge.] It looks like a Bobcat!

(BOBCAT) As a matter of fact, I think we have some Cub Scouts here tonight who also found that program and have been studying the "rules" so that they are ready to join in.

# SCOUTING THE MIDWAY

## August 2004

### Advancement Ceremonies

#### GAMES ADVANCEMENT continued

[List names of Bobcat recipients and call them with their parents to the front of the room.]

As with any program, software or otherwise, we have to understand what we are getting ready to do and how we're supposed to do it before we get started. You guys have done that. Just to help remind the rest of the players, will join with me now in reciting the Cub Scout Promise?

[Hand parents the awards to present to the boys and congratulate them with the Cub Scout handshake.]

To get to the first level, the player has to get through 12 achievements. And like in other computer games, the player has to "learn" how to do things to complete these achievements. In the first level, the achievements include everything from doing physical feats of skill to learning about the flag and holding a flag ceremony to learning make the right decision in unsafe situations. And once you've completed the 12 achievements, another icon is displayed [holds up Wolf badge]. This one looks like a Wolf.  
(WOLF)

Among all of you computer wizards out there tonight, it turns out we have some who have reached this level of the program. [List names and invite them with their parents to come forward.] These players have spent a lot of time learning new skills and have reached the Wolf level. [Hand out badges to parents to give to the boys.]

Once the program advances the players to the next level, the achievements become a little tougher and the players have to make some program choices to complete this level of the program. I guess the program uses "if... then" statements or something. Anyway, at this level, the players again try to complete 12 achievements, but in four different subject areas—God, Country, Family, and Self. Once they've completed 12, a new icon is displayed

[hold up the Bear badge].

(BEAR)

Again, we've got some real program experts with us tonight who have completed these achievements. [List off Bear candidate names and invite them and their parents to the front of the room.] These Cub Scouts have mastered their level to get the Bear icon, but they are encouraged to keep working on this level until the program moves them up to the next level. [Hand parents the awards to present to the boys and congratulate them.]

The Advancement program is a little different than other programs. Because once you've gotten the Wolf icon, you still stay at that level until the program tells you it's time to begin working on the next level. But while you're working at the Wolf level, you still do other things and learn new skills. And as you do, the program gives you bonus icons [hold up arrow points]. An arrow point is awarded each time a boy completes ten electives; a gold arrow point for the first ten and a silver arrow point for each ten after that.

(ARROW POINTS)

# SCOUTING THE MIDWAY

## August 2004

### Advancement Ceremonies

[List off Arrow Point candidate names and invite them and their parents to the front of the room.] These players (in both the Wolf and Bear levels) have really mastered the program and are gaining a lot from it. Tonight we award them with the extra arrow points they've earned. [Hand parents the awards to present to the boys and congratulate them.]



This Advancement program is really a pretty smart program. Whether or not a player gets the icon for a level, the program automatically advances the player to the next level when the player is ready to take on new challenges. For those who have advanced to the level above Bear, they begin to get ready for an even greater, more challenging program that they'll be able to enjoy in just a couple of levels later—it's called the Boy Scout Advancement program. So the players in the next level begin to "prep" for this. Unlike the Wolf and Bear levels, this next level of play involves completing separate activities for which the program recognizes the player. These activities are more challenging than the Bear achievements, but then again, the players are ready for them too. While the player completes the activities, he also works on special challenges—part of the "prepping" I mentioned. This assures that the player will understand the rules and requirements of the program after this one. As the player completes an activities, he gets a mini-icon [hold up Activity Badge pins] and when he has gotten certain mini-icons and completed the "prep" challenges, the program gives him yet another icon [hold up Webelos badge].

#### (WEBELOS)

With us tonight are some players who have done just that. They have worked the program to get several mini-icons (or Activity Badges) and some have even completed the prep challenges to get the Webelos icon. [List names and invite them with their parents and Webelos Den Leaders to come forward.] [Hand parents the awards to present to the boys and congratulate them.]

So the program seems to go on and on. But really, there is a "finish" to the program, and some very hard-working players even reach the pinnacle (the top) of the program by going all out. These players have to "capture" other mini-icons and complete even more of the challenges in this level of the program. But when they have, the program awards them the top icon [hold up Arrow of Light Award]. It takes a lot of program skill and perseverance—sticking to it—just like with any other computer program. This icon is so special, that the players who get it carry it over into the next program, Boy Scout Advancement.

#### (ARROW OF LIGHT)

Tonight we recognize those players who have displayed their skills in the program, have worked hard to master the challenges of the "game" and have come out on top. [List names and invite them with their parents to come forward.] [Hand boys the parent's Arrow of Light pins to present to their parents. Then give parents the awards to present to the boys and congratulate them.]

One final word about this program. Anyone can play. And for the players who Do Their Best, they all come out winners!

# SCOUTING THE MIDWAY

## August 2004

### Run On/ Applause

#### RUN ONS

Scout: Scout walks on carrying a piece of wood.  
Leader: What are you doing?  
Scout: I'm feeling a little board.

1st Scout: I went fishing last week.  
2nd Scout: What did you catch?  
1st Scout: Three bass and one smelt.  
2nd Scout: It did? Which one?

1st Scout: OOOOOUCH, OOOOOOH, OOOOOUCH  
2nd Scout: What's the matter with you?  
1st Scout: A bee's stung my thumb!  
2nd Scout: Try putting some cream on it then.  
1st Scout: But the bee will be miles away by this time.

Cub 1: So we're supposed to do a run-on, right.  
Cub 2: Yup.  
Cub 1: Ya got one in mind?  
Cub 2: Nope.  
Cub 1: Then I guess we'll do a run off.  
Cub 2: Yup.

**Infantry:** Each boy comes in announcing that the infantry is coming, and is only 500 miles away, 300 miles, 200 miles, etc. The last boy comes in carry a very small tree (infant tree).

Cub #1: Which is faster, hot or cold?  
Cub #2: Hot is, you can catch a cold.

#### YELLS

Den Yell: Which den is really fine?  
Which den is only mine?  
Den nine, Den nine, Den nine!

Den Yell: Squirt, squirt, squirt, mooo.  
Tie your shoe, we are the scouts of Camp  
Den Twooo!

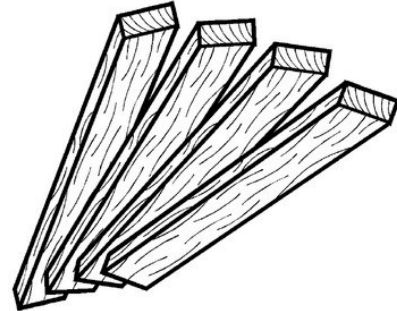

# SCOUTING THE MIDWAY

## August 2004

### Closings

#### JOIN THE CLUB

(Sing to the tune of the Mickey Mouse Club)

If you want to join a club  
That's fun for you and me.  
C-U-B S-C-O-U-T-I-N-G  
Tigers, Wolves and Bears are there  
As well as Webelos.  
C-U-B S-C-O-U-T-I-N-G  
Cub Scouting, Cub Scouting,  
Forever let us hold our Cub signs high  
High, High, High  
Come along and join the fun  
And bring your Family  
C-U-B S-C-O-U-T-I-N-G  
Now it's time to say good bye  
To all our company  
C-U-B - Be here next month  
S-C-O - Or you'll miss all the fun  
U-T-I-N-G



#### SUMMER

S - is for summer, which is already here

U - is for Us boys who need scouting all year.

M - is for the many outings which Cub Scouting does bring

M - is for more fun, cause that's our thing

E - is for every parent who does their share

R - is for a roaring summer program you've planned cause you cared.

After all the boys have said their lines, they turn over their cards to spell "THANKS".

#### WITHIN MY POWER -CUBMASTER MINUTE

I am not a very important person, as importance is commonly rated. I do not have great wealth, control a big business, or occupy a position of great honor or authority. Yet, I may someday mold destiny. For it is within my power to become the most important person in the world in the life of a boy. And every boy is a potential atom bomb in human history.

All about me are boys. They are the makers of history, the builders of tomorrow. If I can have some part in guiding them up the trail of Scouting, on to the high road of noble character and constructive citizenship, I may prove to be the most important person in their lives, the most important person in my community.

A hundred years from now it will not matter what my bank account was, the sort of house I lived in, or the kind of car I drove. But the world may be different, because I was important in the life of a boy.

# SCOUTING THE MIDWAY

## August 2004

### After the Meeting

#### DIXIE CUP COOKING

The cookbook used is called "Cup Cooking" by Barbara Johnson. It is distributed by Gryphon House, Inc. (PO Box 207 Beltsville, Maryland 20704-0207 1-800-638-0928)

The dixie cups referred to are the 5 oz wax coated paper cups (Dixie brand in the US). And these are all cooked in a covered electric skillet.

#### Gingerbread

3 T gingerbread mix

1 T water

Put mix in cup. Add water. Stir well. Bake in electric skillet at 400 degrees 15 minutes or until done.

#### Pineapple Upside Down Gingerbread

1 t salad oil

1 t brown sugar

1 T crushed drained pineapple

Pour oil in cup. Sprinkle sugar on top of oil. Spread pineapple on top of sugar. In separate cup prepare gingerbread as above. Pour over pineapple but do not mix. Bake as above.

#### Molasses Muffins

1 T flour

1/4 of 1/4 t baking soda

1 pinch salt

2 T bran

1 T milk

1 1/2 t molasses

10 raisins

Put flour, soda and salt in cup. Mix well. Mix in bran. Stir in milk and molasses. Stir in raisins. Bake in paper cup at 375-deg 30-40 min.

#### Instant Pudding

2 T instant (not cooked) pudding mix

2 T dry milk

1/3 C water

Put pudding mix and milk in cup. Stir well. Add milk and stir for 2 minutes. Cool in refrigerator.

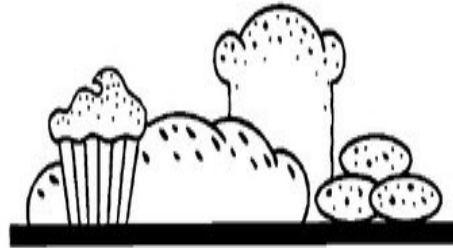

#### Peanut Honey Balls

1 T peanut butter

1/2 t honey

1 1/2 t powdered milk

Put peanut butter in cup. Add honey and then milk. Mix well. Roll into balls. Crush 5 wheat chex with rolling pin (I put them in a ziploc bag & smash them). Roll balls in crushed chex.

*Also, in electric skillet--this time foil lined--*

#### Cheesy Wiener Wheels

Spread small amount of tomato paste on a Ritz cracker.

Cut slice of cheese into 1/4's.

Place piece of cheese on cracker.

Slice wiener into fairly thin circles. Place wiener slice on cheese.

Put on foil in electric skillet at 350 deg until cheese melts.



# SCOUTING THE MIDWAY

## August 2004

### Naturalist

#### DEN MEETING ACTIVITIES

- Make insect cages
- Make ant houses
- Learn how to identify outdoor hazards
- Take a nature hike
- Have boys keep a nature notebook, jotting down discoveries while on field trips
- Make charts showing life cycle of an insect
- Collect tadpoles and watch them grow
- Go on bird watching hike
- Make birdfeeders
- Make a leaf or nut collection
- Make a leaf print
- Invite a naturalist or conservationist to your den meeting to talk about nature

#### PLACES TO GO

- Museum of Natural History (Fair park)
- Fish hatchery
- Zoo
- National wildlife refuge

#### RESOURCE

There is a great magazine called Ranger Rick's NATURESCOPE. It is published by the National Wildlife Federation. It has wonder ideas for teaching and providing activities for school age children. You don't have to be an expert to teach, the activities are simple and easy to understand as well as FUN! The books that are available are:

Incredible Insects	Digging into Dinosaurs	Wild About Weather
Birds, Birds, Birds	Discovering Deserts	Trees Are Terrific
Astronomy Adventures	Amazing Mammals 1	Amazing Mammals 2
Wading into Wetlands	Geology: The Active Earth	Endangered Species
Reptiles and Amphibians	Diving into Oceans	Wild and Crafty
Rain Forests		

You can write for ordering and pricing information. Prices are subject to change, but at the time of this printing they were \$6.00 each

NATIONAL WILDLIFE FEDERATION  
1400 Sixteenth Street, N.W.  
Washington, D.C. 20036-2266

# SCOUTING THE MIDWAY

## August 2004

### Naturalist

# Poison Ivy... COLOR IT ITCHY!

**N**obody wants to get Poison Ivy. It makes your skin get red and break out in very, very itchy bumps.

What's the best way not to get Poison Ivy? By knowing what it looks like!

This is not always easy. Poison Ivy can have shiny leaves or dull leaves. It can grow close to the ground or up on trees and posts. Sometimes, it has tiny white flowers. Other times, it has pale green berries.

But one thing about Poison Ivy never changes. Its leaves always grow in groups of three!

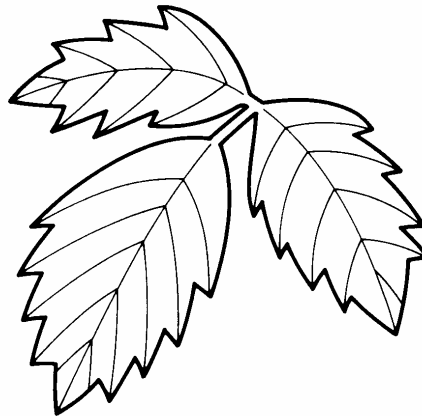

Poison Ivy leaves can have edges with teeth on them. Color these leaves green.

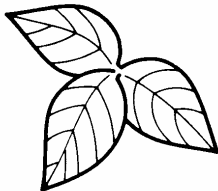

In the spring, Poison Ivy leaves are small and young. Color these leaves red.

Or Poison Ivy leaves can have smooth edges. Color these green too.

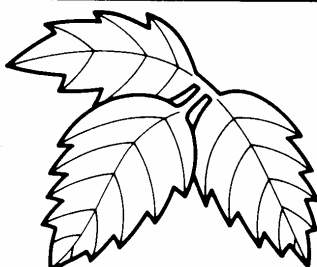
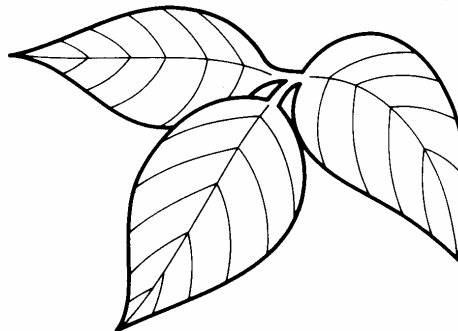

In the summer, the leaves get bigger and turn green.



In the fall, Poison Ivy leaves can turn yellow, red, or orange.



In the winter, Poison Ivy loses its leaves, but not its hair! That's how you can tell the stems of Poison Ivy in the winter. But be careful, it's still poisonous! Color these stems brown.

# SCOUTING THE MIDWAY

## August 2004

### Forester



### JUNIOR FOREST RANGER QUIZ

Circle the correct answer

1. Campfire permits are required for: (a) indoor fireplaces, (b) outdoor areas, depending on local laws, or (c) lighting Halloween pumpkins.
2. The safest way to start a campfire is with: (a) a pile of leaves, (b) gasoline, or (c) small pieces of kindling wood.
3. The best place to ask where forest campfires can be built is: (a) sheriff's office, (b) sporting goods store, or (c) ranger fire warden station.
4. When staying overnight in the forest, before going to bed you should: (a) place heavy logs on the fire, (b) put out your campfire, or (c) arrange to get up every 2 hours to check the fire.
5. When you see a bear in the forest, park, or zoo you should: (a) pull his fur, (b) chase him with a stick, or (c) stay away from him.
6. To cook properly over a campfire, you should: (a) cook over the flames of a large fire, (b) build a small compact fire and cook over the hot embers, or (c) burn a lot of paper to make the fire hot.
7. The best way to put out a campfire is: (a) spread out the embers and cool with dirt or water. Mix thoroughly and check for hot spots, (b) cover it with rocks or (c) let it alone and it will burn itself out.
8. The best spot for a campfire is: (a) inside a rotten log or stump, (b) under a tree, or (c) in a cleared open space away from trees.
9. For camping or burning trash, the following is the most important and practical tool to carry in a car: (a) shovel, (b) bucket of water, or (c) wet blanket.
10. If a fire gets out of hand, you should: (a) get your parents and run to your car and drive away, (b) report it immediately to a forest ranger, or (c) get other Junior Forest Rangers to fight the fire.
11. If your clothes happen to catch on fire you should: (a) keep calm, do not run, roll a blanket around you to smother flames, (b) run for help, or (c) jump up and down real fast.
12. Camp matches should be: (a) kept in a metal container, (b) stored near outboard motor fuel, or (c) placed in the hot sun.
13. A person who is careless and starts a forest fire: (a) is made honorary fire chief, (b) receives a fire prevention award, or (c) can be fined and sent to jail
14. Well managed forests gives us: (a) Smokey Bear, (b) wood, water, wildfire, grass, and outdoor fun, or (c) just lumber, paper, walnuts.

# SCOUTING THE MIDWAY

## August 2004

### Forester

#### JUNIOR FOREST RANGER QUIZ continued

15. A match or cigarette thrown from a car window: (a) is permissible if no one is look in, (b) is permissible if it looks like it has gone out, or (c) is never safe.
16. A windy day is a good time: 9a) to burn trash, (b) to start a campfire, or (c) not to start a fire.
17. A trash-burning incinerator should be: (a) equipped with a good spark arrested, (b) placed under a tree for shade, or (c) used only on windy days.
18. Before lighting an open fire: 9A) people should leave the neighborhood, (b) local fire laws should be checked and obeyed, or (c) drink three glasses of water.
19. Junior Forest Rangers: (a) put out forest fires, (b) start forest fires, or (c) help prevent forest fires.

#### ANSWERS

1.B, 2.C, 3.C, 4.B, 5.C, 6.B, 7.A, 8.C, 9.A, 10.B, 11.A, 12.A, 13.C, 14.B, 15.C, 16.C, 17.A, 18.B, 19.C

#### READ A TREE

Find a smooth cut stump or log end and look closely at the pattern of growth rings. There is a layer of wood for each year of growth. Some tree kinds will show light spring wood and dark summer wood in each year's growth. Count annual rings low on the trunk to find the trees' approximate age.

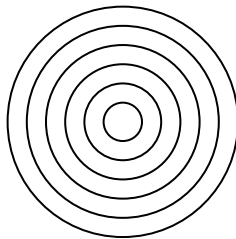

Drought years cause occasional narrow growth rings

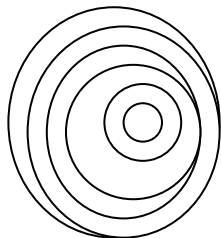
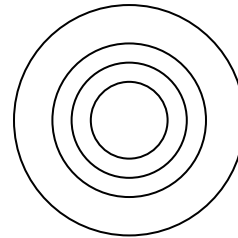

A leaning tree has rings narrower on one side than the other. A tree on a clearing edge may have similar uneven rings.

# SCOUTING THE MIDWAY

## August 2004

### Forester

#### NATURE TRAIL

A nature trail is an excellent learning device much better than books- because scouts can see, smell, and touch an object while they learn. Assuming that you will use it just for one weekend, the markers might be simply 3 x 5 cards taped to the object. Ask a leader who is an amateur naturalist or a nature merit badge counselor to choose the objects to be marked along the trail.

Here are suggestions for writing trail signs. Write them on the spot because desk-written signs are apt to be formal. Here is an example of a good label:



It is not necessary to identify every tree, plant and rock in the area. Your primary purpose should be to identify the most common objects of the natural community and to point to other things in the natural world.

For example, you might have a marker where deer have grazed vegetation, where a beaver has been at work, or where lichens have found a toehold in rock. Another might be a fallen rotting tree, which is a feeding and nesting ground for insects and reptiles.

After going over your trail, the Scout should have some knowledge of common trees and plants. Be sure to remove the trail signs at the end of the activity unless it is to become a permanent nature trail.

Arrange could be made with the Council office to have a day event at one of the Boy Scout Camp available in your area.

# SCOUTING THE MIDWAY

## August 2004

### Forester

#### TOUCH AND FEEL HIKE

- Find a leaf. Is it Hairy or smooth?\_\_\_\_\_
- Do you know what kind of leaf you found? Name it\_\_\_\_\_
- Find a rock. Is it rough or smooth?\_\_\_\_\_
- Find something dry. Can you explain why it is dry?\_\_\_\_\_
- Where did you find your dry item?\_\_\_\_\_
- Find something bumpy. What is it?\_\_\_\_\_
- Why do you think it is bumpy?\_\_\_\_\_
- Find something that is cool to the touch. What did you find?\_\_\_\_\_
- Find something that is warm to the touch. What did you find?\_\_\_\_\_
- Feel the air around you. Is it warm or cool?\_\_\_\_\_
- What do you like best that you found on your hike?\_\_\_\_\_

#### NATURE SCAVENGER HUNT

Check off each as you find or complete it.

- \_\_\_\_\_ Can you find a Ant hill? (Don't touch it)
- \_\_\_\_\_ Can you find any wildflowers?
- \_\_\_\_\_ Find the following insects
- CRICKET\_\_\_\_\_
- GRASSHOPPER\_\_\_\_\_
- BEE\_\_\_\_\_
- SPIDER\_\_\_\_\_
- \_\_\_\_\_ Find the following animal homes
- BIRDNEST\_\_\_\_\_
- COCOON\_\_\_\_\_
- SPIDER WEB\_\_\_\_\_
- \_\_\_\_\_ Locate an animal track. What kind of animal do you think it is?\_\_\_\_\_
- \_\_\_\_\_ Find the following trees
- MESQUITE\_\_\_\_\_
- OAK\_\_\_\_\_
- MAPLE\_\_\_\_\_
- \_\_\_\_\_ Find the following colors on a bird
- BLACK\_\_\_\_\_
- WHITE\_\_\_\_\_
- RED\_\_\_\_\_
- BROWN\_\_\_\_\_
- BLUE\_\_\_\_\_
- \_\_\_\_\_ Find a butterfly

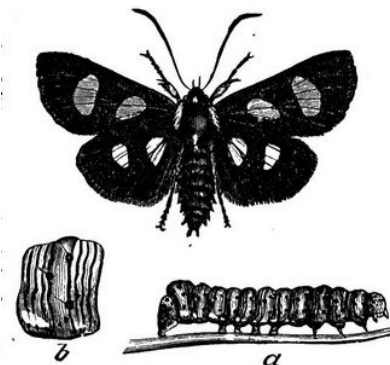

Eight-spotted Forester, natural size. — *a*, larva; *b*, side view of one joint, enlarged.

# SCOUTING THE MIDWAY

## August 2004

### Tigers - Collecting and Other Hobbies

#### Family Activity

#### COLLECTIONS/HOBBY BOARD

Families assemble picture collages that will reflect the collections or hobbies that they participate in together. These boards can be displayed at pack meeting.

#### TO HAVE A HOBBY

To have a hobby is to indulge in some form of play, which exercises our hands as well as our brains, and to take a line that cures our despondent, worried, jittery feelings. When we indulge in a hobby through which we see something taking complete form under our own hands, then we gain self—confidence and self—respect.

Every person should spend five or six hours a week at some creative task in which he can submerge himself completely.

The hobby should be something in which a person may excel and in which he takes a keen delight. There is relaxation and comfort in doing something for the sheer delight of doing it. This means, naturally, that one's hobby may change form many times in a lifetime, but even the changes are good, because every one gives us something new to think about, a new approach to the world, a new way of seeing things. Something can be found that will give a sense of self—completion, of creation and of tranquillity.

#### POSSIBLE HOBBIES YOU CAN DO AS A FAMILY

Kite club  
Karate  
Bicycling  
Gardening  
Join or create local **family** book clubs  
Pottery  
Collecting  
Leather working  
Clay modeling  
Ceramics  
Painting  
Drawing  
Writing  
Raising pets  
Looking after an aquarium  
Making airplanes, boats, doll houses.

Collecting may seem an insane pursuit to many people, but with a little ingenuity it can be made fascinating and challenging. One stamp collector — stamp collecting has been called "King of Hobbies" — hinges an issue of a country's stamps in a frame around the page, and then in the middle he writes particulars about it: when it was adopted, the artist who designed it, why this design was chosen, and any other interesting matter he can glean from the encyclopedia, the history of the country, and the daily papers.

This is a more thrilling way to go about collecting than the mere scraping together of a lot of something. It is a plan that can be adapted to building collections of autographs, coins, buttons, insects or trading cards.

# SCOUTING THE MIDWAY

## August 2004

### Tigers - Collecting and Other Hobbies Den Activity

In prospecting for a hobby we should not forget reading, or we should leave enough spare time from other things for this aid to intellectual growth.

A hobby satisfies the desire in all of us to create something. There are a thousand and one ways in which people satisfy their creative urge. In choosing a hobby, the really big question is: Will it give you fun and enjoyment? It must interest you. It must be something you do because you want to do it.

#### Who Collects What

- |                       |                   |
|-----------------------|-------------------|
| 1. Rock Hound         | A. Stamps         |
| 2. Folk Singer        | B. Recipes        |
| 3. Numismatist        | C. Timetables     |
| 4. Ham Radio Operator | D. Coins          |
| 5. Cook               | E. Old furniture  |
| 6. Lexicographer      | F. Call numbers   |
| 7. Philatelist        | G. First editions |
| 8. Antique Collector  | H. Ballads        |
| 9. Railroad Buff      | I. Obsidan        |
| 10. Book Lover        | J. Words          |

(Answers: 1. I, 2,H 3,D 4,F 5,B, 6,J, 7,A 8,E 9C,10,G)

☺Which is heavier, a pound of feathers, or a pound of gold? Typically the answer is they are both the same - one pound. However, to be exactly correct, gold and other precious metals are weighed in Troy weight, which has only 12 ounces to the pound. Feathers are weighed in Avoirdupois weight, which has 16 ounces to the pound. So technically the pound of feathers weigh more.

It's interesting to learn about your friends' hobbies and collections. They like to hear about your interests, too. Tell your den about something you like to do for fun or like to collect.

\*Tell your den about a favorite hobby or activity or

\*Show or tell your den about something you like to collect.



# SCOUTING THE MIDWAY

## August 2004

### Cubmaster Corner - Involving the Family

#### INVOLVING THE FAMILY

The Boy Scouts of America has a deep interest in the strength of the family. Its own aim to develop boys, young men and women, into participating citizens possessing good character who are physically, spiritually, and mentally fit demands that the movement have an active concern for the family.

A child's attitudes, personality, and the foundation for emotional stability are formed at a very early age. The influence of the family is primary, not only in the sense that it precedes the influence of others, but also in the sense that it is of greatest importance.

The world changes and social norms change. Social pressures come from different directions. The family faces problems today that are far different from those faced by a family only two generations ago. The Boy Scouts of America is continually examining its relevance and effectiveness so that it remains useful as a support resource for the family.



#### WHAT IS A FAMILY

**We all know that a family is much more than a Webster's definition.**

A family is people giving and receiving love. We seldom come straight out and say, 'Son, I love you. It doesn't matter if I don't like what you do, I LOVE you.'

A Family is people getting angry with each other, but still loving one another.

A Family is loving the difference about each other.

A Family is people talking and listening to each other...communicating.

A Family is people caring about what happens to each other, and letting it show.

A Family is people laughing and crying without feeling ashamed of it...expressing themselves naturally.

A Family is people sharing with each other and with others.

A Family is people reaching out instead of fencing in...to each other and neighbors and friends.

A Family is a place for having fun, also for sharing sorrows and healing the hurts.

A Family is people giving strength to each other; caring and letting it show; leaning on each other; feeling loyal to each other; in other words LOVING one another.

Good family life is never an accident, but always an achievement by those who share it.

# SCOUTING THE MIDWAY

## August 2004

### Cubmaster Corner - Involving the Family

#### TODAY'S FAMILY

In our new and changing times the role of the family has changed drastically. Where once the families worked together and played together, family values were automatically transferred to the offspring by just being in close contact.

Cub Scouting has been based on the traditional family but now is faced with a great variety of family forms. We must pay attention to the fact that a great percentage of our Cub Scouts come from non-traditional families. Types of families include adoptive, communal, extended, foster, same sex, shared, single parent and household headed by grandparents, aunts, uncles, or siblings. This is not the scenario of the typical beaver Cleaver household. However, as far as Scouting is concerned whomever a boy lives with is his family.

The family, whatever structure it is, still provides the base of security for today's youth. The caring, sharing, loving and the sense of belonging are what make good relationships. Along with the basic needs families face, they also must develop wholesome and string personalities. It is with this in mind that Scouting helps the boy grow.

#### WHAT CUB SCOUTING DOES FOR FAMILIES

When parents work with their sons and share with them as they take part in Cub Scouting, family relationships are strengthened, discoveries are made, and each new day brings more exciting adventure.

As parents work with other adults in Cub Scouting, they make new friends and become acquainted with people they would not otherwise meet. Concern for the boys is a common bond between parents.

Community spirit is strengthened and community leadership is developed out of Cub Scouting adult efforts. Adults get a renewed sense of certainty and confidence when boys and adults work together in harmony with a purpose.

Cub Scouting provides a rich opportunity for families to grow together.

Scouting supports today's family with

- Specific programs
- Role models
- Surrogate parents
- Instrumental and incidental learning
- Social network
- Survival skills
- Facilities (camps for families, etc)
- Activities, events

#### THE FAMILY'S RESPONSIBILITIES

While you provide your interest, skill, and time in developing a good Cub Scout program, the family provides help by supporting the den and pack. Families can help in many different ways, but there are some specific things expected of all families.

# SCOUTING THE MIDWAY

## August 2004

### Cubmaster Corner - Involving the Family

#### ADVANCEMENT RESPONSIBILITIES

- Parents are expected to work with their son on achievements and electives.
- Parents are expected to give their son the opportunity to pass his achievements and electives. Who better than his parents knows when he has done his best? (Webelos leaders or activity badge counselors pass the Webelos on their advancement.)
- Parents are expected to participate in all advancement ceremonies when their boy receives his badges. They should be asked to present his badge to him. Parents are a part of the advancement plan from start to finish.

#### RESPONSIBILITIES TO THE PACK

- Parents are expected to support and take part in all pack activities.
- Parents may be called upon by the pack committee or the Cubmaster to help occasionally at pack meetings or with special pack activities.
- Parents are expected to help with pack finances by making sure their son pays his dues promptly. Suggest that parents provide ways for the boys to earn the amount needed for den dues. This will help teach the boys the value of money and the importance of carrying out financial obligations.

#### RESPONSIBILITIES TO THE DEN

- Parents are expected to cooperate with the den leader in every way possible. This could include helping at an occasional den meeting on a specific project or activity, provide refreshments, transportation, telephoning, or assisting with den outings.
- Parents can help the pack earn the national Summertime pack Award as well as help the den qualify for the den participation ribbon.
- Webelos parents may be called upon to help teach an activity badge.
- Parents will be an important part of the Webelos overnight campouts.

#### PACK/DEN RESPONSIBILITIES TO FAMILIES

- It is easy to list all the things that families should do for the program, but it is important to remember that the Scouting program, as represented by packs and den, has duties towards the families as well. They include:
- To provide a well planned, year round program of activities in the den and pack, which meets the aims of Cub Scouting.
- To provide trained, qualified and enthusiastic leadership for all activities
- To provide training for parents and keep them informed.
- To provide activities which strengthen the family and give them opportunities to work and play together.

# SCOUTING THE MIDWAY

## August 2004

### Cubmaster Corner - Involving the Family

#### WHAT DO WE MEAN BY FAMILY PARTICIPATION?

What is parent participation? It might be a mother helping her son make an Indian vest for his den stunt, or a dad hauling home some old scrap wood to assemble a den game chest for his son's den. It could be these and many other helpful things parents do. But wait...we didn't say parent cooperation, we said parent participation...and the two are entirely different things. Too many times we simply send our children to someone away from home to let others worry about them. This is not true in the Cub Scout program because the entire family participates.

Family participation is important to the success of a pack. Leaders must always remember that the Cub Scout program was designed for parent's op use with their sons. Parents simply do not let their son join Cub Scouting - they join with them.

It starts with you, the Cubmaster, den leader, pack committee member. Be prepared with a few simple rules and procedures that your pack has agreed on. If you want parents to participate and cooperate, tell them exactly what they're in for. What you want them to do, and what they can expect from the Cub Scout Program.

It isn't fair for leaders to expect cooperation and participation unless they have made it clear just what is expected. Families should know about these responsibilities before, not after, you have accepted the boy's application to join.

Someone from the pack should visit the home, or have a meeting with all new families, get to know the family, and discuss the Cub Scout program and purposes with them. Don't assume they know them. Some suggestions on topics to be covered:

- Review the parent agreement on the Cub Scout application.
- Review the parents supplement in the boy's handbook.
- Review their responsibilities to the pack and den.
- Some packs furnish a copy of the Cub Scout Family Book to each new family. This is an option that you could consider.

#### FAMILIES CAN HELP!

There are many different ways families can help. A few of these are listed below:

##### Den Meetings

- Furnish refreshments
- Transportation for field trips
- Help on den projects
- Leadership for special activities

##### Pack Meetings

- Attendance at meeting
- Serve on pack committee
- Lead a special activity
- Provide transportation for pack trips
- Support pack money-earning projects

# SCOUTING THE MIDWAY

## August 2004

### Cubmaster Corner - Involving the Family

#### THINGS TO REMEMBER

Start the families off slow. Maybe ask them to be judges at a pack or den function. Then move them up to transportation. Then maybe to help at day camp or twilight camp. Remember to go slow and to watch for signs of needing help. Don't burn out a volunteer because they couldn't say no. If they won't help directly with the pack why not offer a special bead for the boys to wear when their parent or parents attend functions. This will persuade the boys to ask their parents to come with them.

Again, make sure den leaders are aware of the family situation. This should include knowing custody arrangements, to avoid releasing the boy to the wrong parent in extreme cases. Be aware of too many Father/Son or Mother/Son events, which may exclude many of the boys. In some cases it is appropriate to have some parents who are willing to provide a surrogate parent situation where needed for events like Webelos campouts.

Remember that many pack involvement need not be a full time job. Parents can provide a phone chain or help in a bake sale. Activities should be parent friendly. Make sure that a couple of outgoing adults are near the door to greet everyone to make sure that families feel welcome and comfortable. Nametags are a big help. Thank families for coming. Make sure that siblings are made to feel welcomed too. If some parents seem awkward about joining in, ask them to do small task such as passing out nametags, selling tickets, serving refreshments. In this way, they become part of the group.

#### ADDITIONAL IDEA FOR INVOLVING FAMILIES

Parent/Guardian Meeting for the pack Before the annual program planning meeting for the pack, be sure to meet with the families for their input on what activities they would be interested in attending and supporting.

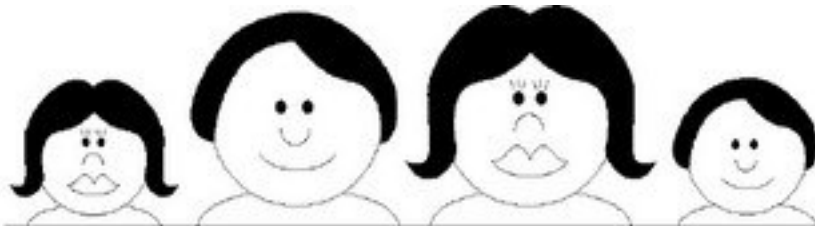

**WE ARE A PACK  
FAMILY**

**"Re involved"**

# TIME IN A CAPSULE

## September 2004

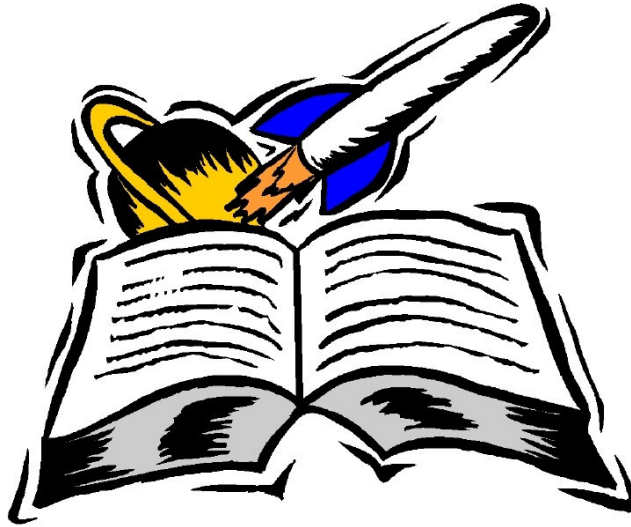

The new Scouting year starts us thinking about the future and what it will hold. Dens can build a time capsule to be opened in the future showing what Scouting is like today. Be sure to be opened in the future showing what Scouting is like today. Be sure to include your den and pack photos, newsletters, pack roster and perhaps videotape of your pack meeting. Present these at the pack meeting as you build a pack time capsule of your pack's history and hopes for the future. Awards could be taken from a time capsule as they are presented to Cub Scouts. The dens could explore space and new frontiers. How about holding a space derby?

Cub Scout Theme .....	03
Webelos – Communicator .....	18
Webelos – Citizen.....	27
Tigers - Fun at the Zoo.....	30
Cubmaster Corner - Boy Discipline and Behavior .....	32

# TIME IN A CAPSULE

## September 2004

### Desiderata

Go placidly amid the noise and excitement of your meeting,  
And remember that this is one sign of good Scouting.  
As far as possible without surrender  
Be on good terms with all your fellow leaders.  
Plan your programs carefully and cheerfully;  
And listen to others,  
Even the youngest Wolf Cub;  
He will give you many moments of Joy.  
Avoid loud and aggressive gatherings of Scouters,  
Except when you're part of one.  
If you compare your pack with others,  
Do not become vain or bitter;  
For success can only be judged by the smiles on their faces.  
Enjoy your achievements as well as your plans.  
Keep in mind the Aim of the movement,  
However hard to understand at times,  
It is a real possession in the changing fortunes of time.  
Exercise caution with your pack funds;  
For a Cub works hard for his dues.  
But let this not blind you to what Scouting is all about..  
Baden-Powell wrote it himself; Camping and the Outdoors.  
Be yourself.  
Especially, have fun.  
Neither burn out too soon;  
For in the face of all aridity and disenchantment  
Those boys are depending on you.  
Take kindly the counsel of your Service Team,  
They will help you all that they can.  
Nurture strength of spirit in case of a failure  
But do not blame yourself... you have done your best,  
And what you think of as failure may be super fun to your Cubs.  
Beyond a wholesome discipline,  
Be gentle with yourself.  
You are the most important person in Scouting;  
We need more adults like yourself  
To help the youth of this world.  
And whether or not it is clear to you,  
You are molding the future of this country.  
Therefore, be at peace with God,  
Whatever you conceive Him to be,  
And whatever your labors and aspirations,  
In the noisy confusion of your meeting  
Keep peace with yourself.  
With all its hard work and sometimes frustration,  
It is still a wonderful movement.  
Be cheerful  
Strive for good Scouting ...

From Circle Ten Council  
Thanks to Jim Speirs, jim.speirs@canrem.com



# TIME IN A CAPSULE

## September 2004

### Gathering Activities

#### MOON, SUN and STARS – Audience Participation

**CHIEF:** (Stands with arms folded across chest and says "Ugh")

**SUN:** (Covers eyes with hands)

**MOON:** (Frames face with hands and smiles)

**STARS:** (Blink rapidly)

Long, long ago the Indians had no fire and no light. They suffered much during the cold of winter and they had to eat their food uncooked. They also had to live in darkness because there was no light.

There was no **SUN**, **MOON**, and **STARS** in the sky. A great **CHIEF** kept them locked up in a box. He took great pride in the thought that he alone had light. This great **CHIEF** had a beautiful daughter of whom he was also proud. She was much beloved by all the Indians of the tribe.

In those days the raven had the powers of magic. He was a great friend of the Indians and the Indian **CHIEF**. He wondered how he might make life more comfortable for them.

One day he saw the daughter of the **CHIEF** come down to the brook for a drink. He had an idea. He would put a magic spell on her. In time, a son was born to the daughter of the **CHIEF**. The old **CHIEF** was delighted and as the boy grew, his grandfather became devoted to him. Anything he wanted he could have.

One day he asked the old **CHIEF** for a box containing the **STARS**. Reluctantly the old **CHIEF** gave it to him. The child played for a while by rolling the box around. Then he released the **STARS** and flung them into the sky. The Indians were delighted. This was some light, though not quite enough.

After a few days the child asked for the box containing the **MOON**. Again the old **CHIEF** hesitated but finally the boy got what he wanted. Again, after playing awhile with the box, the boy released the **MOON** and flung it into the sky. The tribesmen were overjoyed. But still there was not light enough, and the **MOON** disappeared for long periods.

Finally the child asked for the box with the **SUN**. "No" said the old **CHIEF**. "I cannot give you that." But the boy wept and pleaded. The old **CHIEF** could not stand the tears, so he gave the box to him. As soon as he had a chance, the child released the **SUN** and cast it into the sky.

The joy of the Indians knew no bounds. There was light enough and heat as well. They ordered a feast of the **SUN** and all the Indians celebrated it with great jubilation. And the old **CHIEF** was happy. He had not known the **SUN**, the **MOON**, and the **STARS** could mean so much for the comfort and happiness of his people. And for the first time, he too, enjoyed himself.





# TIME IN A CAPSULE

## September 2004

### Openings

#### OUT IN SPACE

Setting: Four Cub Scouts are standing on stage looking up to the sky.

**CUB 1:** What's out in space?

**CUB 2:** Mostly lots and lots of space, but also billions and jillions of stars, galaxies and solar systems, planets, and moons, blazing comets and deadly rays.

**CUB 3:** Yeah, and sometimes even people!

**CUB 4:** That's what's out in space! Let's all stand and remember the American flag flying on the moon. Please join with us in the Pledge of Allegiance.

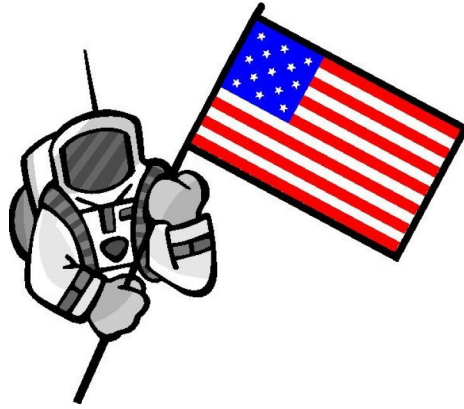

Great Sauk Trail Council



#### ON THE MOON OPENING CEREMONY

*Props.* Cut Out large black footprints and lay them on the floor leading up to the flag stand. Cub Scout will follow the footprints as they carry in the flag.

*Narrator:* The United States has much to be proud of. For instance, the United States was the first country to land a person on the moon. Each evening when the moon shines, we know that Old Glory is still there on the moon's surface, ever since that magical day it was placed there in 1969. As we join together in the Pledge of Allegiance, let us be thankful for the courageous astronauts and for the human ingenuity and

technology that make journeys into space possible. Perhaps you know many former Scouts were among the pioneers in space. Maybe some of our own Cub Scouts will leave footprints on the moon, too. Think of that! Please join in the Pledge of Allegiance.

#### LIFE ON OTHER PLANETS

*Setting:* Form the pack in a large circle.

**CUBMASTER:** " We've had lots of fun this month imagining what life may be like on other planets. We've looked into the night sky and enjoyed its beauty. Some of you may have learned too, that the North Star, Polaris, is fixed overhead and that it is used by space travelers and ship captains to find their position. In Cub Scouting we have our own North Star, the Cub Scout Promise. Like the North Star, the Promise is a guide for people on earth. If we follow the Promise, we can be pretty sure that we will be good men. Please join me now in repeating the Cub Scout Promise". (Make the Cub Scout sign and lead promise).

# TIME IN A CAPSULE

## September 2004

### Den Activities

#### SPACE CHARADES

Play a game of charades using space-related words and phrases:

Blast off  
Shuttle Pilot  
Countdown  
Moon Rock  
Space Station  
Orbit  
Launch Pad  
Lunar Lander

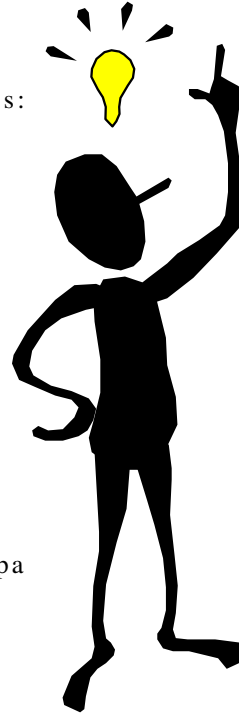

#### SPACE TRIVIA

1. What is the name of our galaxy?  
a) M100 b) The universe c) The Milky Way d) Europa
2. By weight, the Sun is approximately 70 percent \_\_\_\_\_?  
a) oxygen b) helium c) nitrogen d) hydrogen
3. Saturn is our solar system's \_\_\_\_\_?  
a) brightest planet b) second largest planet c) smallest planet d) hottest planet
4. Lunar exploration formally began in what year?  
a) 1959 b) 1964 c) 1969 d) 1972
5. Is the American flag still on the Moon?
6. Who was the first American in space?  
a) Alan Shepard b) Mickey Mantle c) Jim Lovell d) Neil Armstrong
7. \_\_\_ is the second planet from the Sun?  
a) Mars b) Mercury c) Venus d) Earth
8. What was the first Earth orbiting satellite?  
a) Viking I b) Sputnik c) Lunar Orbiter d) Explorer I
9. What does ISS stand for?  
a) Institute of Silly Songs b) International Space Society  
b) International Space Station d) International Saturn Society
10. \_\_\_ is the third planet from the Sun?  
a) Earth b) Venus c) Jupiter d) Neptune

ANSWERS: 1-c, 2-d, 3-b, 4-a, 5-Yes, 6-a, 7-c, 8-d, 9-c, 10-

# TIME IN A CAPSULE

## September 2004

### Crafts

#### ALIEN HEAD

*Materials:* 1-2 yards green fabric, 1-1 1/2 feet elastic, green thread, needle, plastic bags

*Directions:*

Cut out a large circle of green fabric. The larger you want the head, the bigger the circle. Then, hem the ends of the fabric, but leave enough space to get the elastic through. Then, when you are done hemming, pull the elastic through the space in the hem. When the elastic is through, connect both ends together with the thread. Stuff your head with plastic bags to make it stand up, put it on your head (tuck your hair under), and you're ready to go

#### ALIEN SPECIMENS

*Materials:*

clear glass or plastic jar with tight-fitting lid  
Sculpey bake-hard craft clay; little plastic (or glass) eyes of various sorts  
Acrylic paints  
food coloring  
paper for labels  
Cotton Balls  
Glue  
your computer.

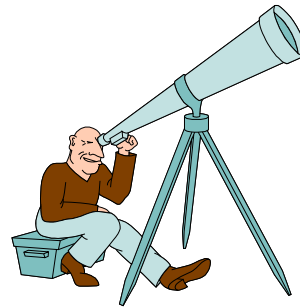

*Directions:*

Paint the lid of your jar black, so it will look like a real scientific specimen jar. Using the Sculpey, model your creature, making sure it will fit inside the jar. Poke the eyes into it, then take them out.

When your creature is finished, bake in a 325-degree oven until the thing turns uniform brown. Let it cool fully. Paint, and glue in the eyes.

Decide what you have just created. Give it a name like, Twiggie Stimjiggy From Mars. Create the label for your jar. On your computer, create a scientific specimen label. Print the label. When the paint on your alien is dry, it's time to fill the jar with water and insert your "specimen" into the "formaldehyde".

Tint the water with food coloring. I suggest green or orange for a great effect. Wind threads of cotton around your alien. Glue your label to the jar.

<http://familycrafts.about.com/>

# TIME IN A CAPSULE

## September 2004

### Songs

#### SONG FOR A SPACE THEME

*(Tune: Clementine)*

On the launch pad, on the launch pad,  
We can see for miles around.  
In a second we have lift-off  
With our ship high off the ground.

#### CHORUS:

Into space now, into space now  
Heading for the great unknown.  
Shooting stars with tails blazing.  
This could be the twilight zone.

Total darkness now surrounds us  
And our bodies have no weight.  
Oh my goodness! There's my napkin,  
Cup and saucer and my plate.  
CHORUS

There's the moon now right before us  
Glowing silvery and gray.  
How I long to take a picture  
But my camera floats away.  
CHORUS

Moving onward through the darkness  
Where the stars so brightly shine.  
I'm amazed at what's before us.  
So I continue down the line.  
CHORUS

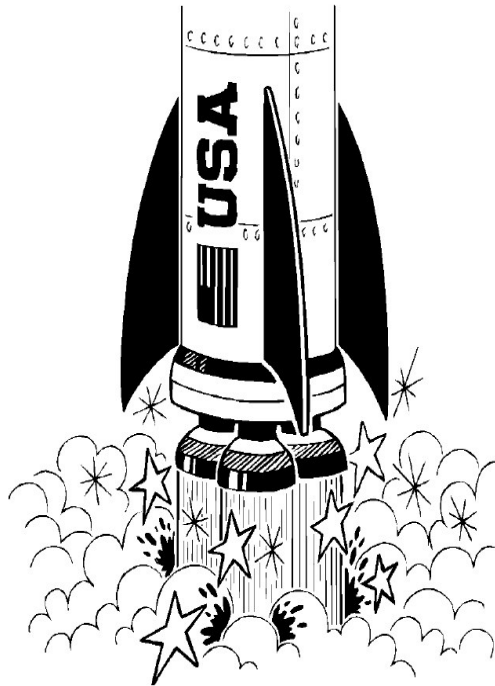

#### STARS AND PLANETS

*(Tune: Frere Jaques)*

Sing as a round.

Stars and Planets, Stars and planets,  
Comets too, Comets too!  
Meteor shower, meteor shower,  
Zoom zoom zoom, zoom zoom zoom



# TIME IN A CAPSULE

## September 2004

### Songs

#### SPACE DERBY SONG

*(Tune: Camptown Races)*

Cub Scouts all join in the song,  
Doo-dah, doo-dah!  
Spaceship wire is mighty long.  
Oh, doo-dah day!

#### CHORUS:

Going to fly so fast,  
Going to get ahead.  
Bet my money on a blue spaceship,  
Somebody bet on the red.

Spaceships - red, blue, green, and gray,  
Doo-dah, doo-dah!  
Running on the wire today.  
Oh, doo-dah day!

#### CHORUS

They're the pride of all the lads,  
Doo-dah, doo-dah!  
Built by Cub Scouts, Moms and Dads.  
Oh, doo-dah day!

#### CHORUS

Bay Area Council Pow Wow, 1994

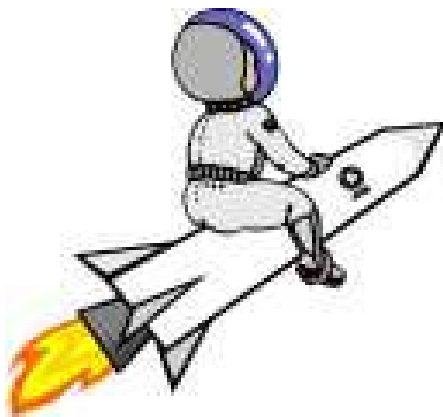
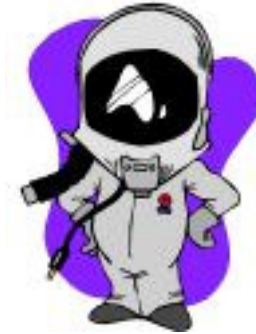

#### ASTRONAUT SONG

*(Tune: If You're Happy and You Know It)*

Outer space is where I really like to go.  
I ride inside a spaceship, don't you know.  
I like to travel near the stars  
Wave to Jupiter and Mars  
Outer space is where I really like to go.

# TIME IN A CAPSULE

## September 2004

### Skits

#### SCIENCE CLASS IS LOOKING UP

*Setting: Teacher and students enter classroom. Bell rings.*

**Teacher:** Class, today we will begin our study of astronomy.

**Student 1:** *(Loud whisper to Student 2)* What's that?

**Student 2:** It's way over your head.

**Teacher:** Attention please, students. As I told you, we're going to take up a new topic - space.

**Student 1:** *(Loud whisper to Student 3)* Did you hear that? He said we are going to take up space!

**Student 3:** That's all you ever do --- take up space!

**Teacher:** What is at the center of gravity?

**Student 2:** The letter "v".

**Teacher:** Of all the planets, which one can we see most easily any time of year?

**Student 1:** Earth!!

**Teacher:** What will happen when the sun shines at night?

**Student 3:** That'll be the *day!*

**Teacher:** Did you students know that they found bones on the moon?

**Student 1:** Wow! I guess that means the cow didn't make it after all!

**Teacher:** And speaking of the moon, I suppose we could call the Earth and the moon good friends.

**Student 2:** I should say so! They've been going around together for an awfully long time!

**Teacher:** Can someone please tell me which is closer to us, South America or the moon?

**Student 3:** The moon, of course.

**Teacher:** How could you say that?

**Student 3:** That's easy. I can see the moon from here, but I sure can't see South America.

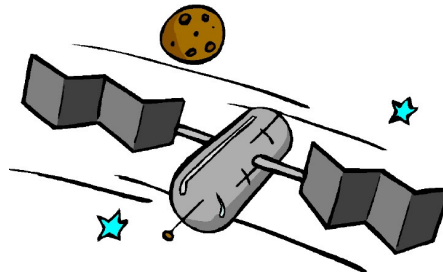

# TIME IN A CAPSULE

## September 2004

### Skits

#### SCIENCE CLASS IS LOOKING UP *continued*

- Teacher:** By the way, do you know if there are any fish in outer space?
- Student 1:** Sure! They call them starfish!
- Teacher:** Who knows what a star with a tail is called? Can you name any of them?
- Student 2:** Yeah. Haley's Comet, Mickey Mouse, and Lassie.
- Teacher:** That's all for today, class. Don't forget our field trip tomorrow night. We're going to the planetarium, where the telescope is, to see an all star show

-- Crossroads of America, 1992

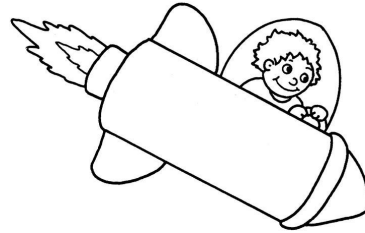

#### LIFE ON OTHER PLANETS

*Boys come out representing each planet.*

- Mercury:** (*Jumping around*) You'd really get a hot foot if you lived on me. The temperature is 950 on Mercury.
- Venus:** (*Moving hands as if parting fog*) You might think that Venus is lovely as can be. But with these 200 mile thick clouds it is sure hard to see.
- Mars:** (*Dressed in red*) From its canals to polar caps Mars is hard to understand. I'm frozen ice and barren rocks, but I do the best I can.
- Jupiter:** (*Strolling with hands behind back*) If you like to walk in the moonlight, you'd love to live on me because I have not just one moon but thirteen for you to see.
- Saturn:** (*Wearing a lab coat, a la Carl Sagan*) I'm not just a 3-ring circus as people thought me to be. For Saturn has billions and billions of bands that you can see for free.
- Neptune:** (*Wearing a lab coat and shivering*) I'm named for King Neptune who lives in the depths of the sea. But old King Neptune would be a frozen fish if he were to live on me.
- Uranus:** (*Wearing big boots and picking up feet with difficulty trying to walk.*) I'm so much bigger than the Earth that walking would not be fun. Each step would just exhaust you. On Uranus you'd weigh a ton.

# TIME IN A CAPSULE

## September 2004

### Skits

#### LIFE ON OTHER PLANETS continued

**Pluto:** *(Smallest Cub with thumbs stuck under suspenders)* I may be last. I may be least. I'm even harder to find. But as long as you remember I'm Pluto, I guess I really don't mind.

**Earth:** You've heard from all my neighbors and what they have to give. Now aren't you glad that it's on Earth that you decided to live?

-- Crossroads of America, 1992

#### SPACE TRAVELERS

Cast: Two space aliens, Ma, Pa, Sonny, and Sis  
Setting: *The two aliens arrive in front of the hillbilly family seated around a cook pot or a campfire.*

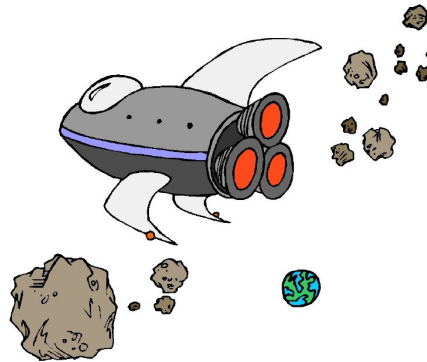

**Ma:** Howdy strange lookin' green fellers.  
What ya'll want?

**Alien #1:** Tell us how to get to Bloomington.

**Ma:** Well I don't rightly know, but I'll ask Sonny. Oh Sonny, how do you get to Bloomington?

**Sonny:** Well Ma, I don't rightly know, I'll ask Sis. Sis, how do you get to Bloomington?

**Sis:** Well Sonny I don't rightly know, let me ask Pa. Pa, how do you get to Bloomington?

**Pa:** Let me see now...I don't rightly know how to get to Bloomington.

**Alien #2:** Boy, you Earth people are really dumb.

**Pa:** You're mighty uppity for a little green feller, aren't ya? But you see it's this way. We may be dumb, but we ain't lost!



# TIME IN A CAPSULE

## September 2004

### Games

#### FLYING SAUCERS

See who can sail the most cardboard discs, one at a time, into a box 6 or 7 feet away

#### ORBITING THE MOON

This is a race for the entire family! Each den's families make up a mission to the moon. The moon is a marker about 30' from the starting line. A small Cub Scout is the "nose cone". Two other children are the first and second stage of the rocket. On signal, parents pick up the nose cone and the two rocket stages and begin carrying them toward the moon. Halfway there, one of the stages is put down and joins the run. At the moon, the second stage is put down and also joins the runs. The race ends when all family members are back at the start and the nose cone is set down gently on a chair.

-- Greater St. Louis Area Council

#### ROUND THE MOON

All the Dens line up at the end of the room. Each Cub places his hands on the waist of the Cub in front so the Dens form a 'rocket'. A chair is placed at the far end of the room opposite each Den; these are the 'moons'. On 'Go', the Dens run the length of the room, around their 'moon' and back into orbit. As they pass base, the 'rockets' drop a section each time and the Cubs sit down there one by one, until finally the 'nose cone' - the first in line 'returns home'. The first team to be sitting down is the winner.

-- Greater St. Louis Area Council

#### ALIEN EGG

Divide the boys into pairs. Tell them that you have been given an alien egg (a ball about volleyball size wrapped in aluminum foil). The egg cannot be moved from place to place unless it is carried between the heads of two people. The egg is unique in this way because it must be in contact with human brain waves while it is in motion or the baby alien inside might get upset, break open the egg, and eat the floor. The object is for each pair to crawl sideways to the end of the playing area and back. They must then exchange the egg with the next pair in line without using their hands.

-- York Adams Council



#### MOON RACE WALK

Materials: Really, really, really big gum boots or galoshes. Divide the boys into two teams. Have them take off their shoes and stand in two lines. Place the huge boots at the starting line and have the boys put on the "moon boots" race down to a turn-around point and return to give the boots to the next in line. Continue until all boys have finished.

York Adams Council

# TIME IN A CAPSULE

## September 2004

### Advancement Ceremonies

#### THE ROCKET

Threading a straw with a launch line makes the rocket. Leader blows up a long balloon. He attaches it to the straw with tape. The Cub then goes to the other end of the launch area and waits by his parent. Cubmaster then attaches the award to the balloon and releases the balloon. It rockets to the parent for the award to be given to the Cub.

-- Great Sauk Trail Council

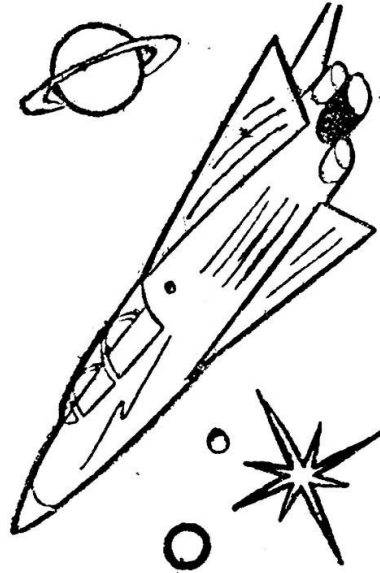

#### ROCKET TRAVEL

*Preparation:* Ceremony board resembles a chart of the sun and planets with "Cub Scouts" as the sun and ranks as planets (use Cub Scout insignia stickers). Make a small blue and yellow cardboard rocket for each boy getting a badge and place it on or under his rank. If a loop of masking tape is placed on the back of each rocket, the Cubmaster can move the rocket to the new rank as the adult family members are presenting the badge.

*CUBMASTER:* Will the den chiefs [or den leaders] please bring forward the Cub Scouts who are ready for advancement, along with their parents or guardians?

"Cub Scouts, we are happy to see that you have taken another flight forward in our Cub Scouting galaxy. These Cub Scouts have done a fine job in our pack. They are progressing through the Cub Scouting galaxy this wouldn't be possible if it weren't for the interest and help of their families. I'm proud of the families in our pack. As I move your rocket forward in our galaxy, your parents or guardians will present you with your badge."

(The Cubmaster or den leader calls off the names as he/she moves the rockets to the appropriate ranks on the ceremony board while parents present the badges. The Cubmaster congratulates the boys and adult family members with the Cub Scout handshake.)

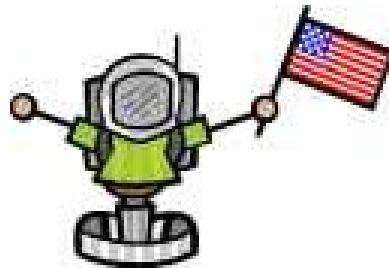

# TIME IN A CAPSULE

## September 2004

### Run On/ Applause

#### BLAST OFF CHEER

We're blasting off into space!  
While we spread goodwill  
We'll leave no trace  
We'll do our best  
Right down to the wire  
Helping our pack soar higher and higher!  
(Everyone makes a rocket sound.)



#### MAN IN THE MOON APPLAUSE

Circle face with hands and say "I eat green cheese."

#### SATELLITE APPLAUSE

Move right hand in a circle over head, opening and closing fist while saying in a high falsetto voice, "Gleep-Gleep, Gleep-Gleep"

#### BLAST OFF APPLAUSE

Start counting backwards from 5 to 1. Bend knees a little more on each count until you are in a squatting position. Then say "Blast-Off!" and jump up.



#### RUN ONS

Did you hear about the astronaut who stepped on chewing gum?  
He got stuck in ORBIT!

Where do astronauts leave their spaceships?  
At parking meteors!

How does a robot shave?  
With a laser blade!

What did Neptune say to Saturn?  
Give me a ring sometime!

What kind of ticks do you find on the moon?  
Luna-ticks!

# TIME IN A CAPSULE

## September 2004

### Closing



#### THE SKY IS THE LIMIT

Den Leader: Cub Scouts, it wasn't long ago that we heard some people say. "The sky is the limit." That meant that a man could make anything of himself he wanted...at least, on the earth. Well, that limit is off now. There us almost no limit to what you can aspire to do, either on earth or in space. Our astronauts showed us that.

Committee Chairmen: Colonel "Buzz" Aldrin, the second man to walk on the moon, was a member of Troop 12 in Montclair, New Jersey. He once said that a group of Scouters, 'Set your goals high and settle for nothing less than accomplishment. Don't settle for mediocrity.'

Cubmaster: How well you perform will depend on how you accept the new challenge, which says, "The sky is NOT the limit." A Cub Scout who does his best in everything he undertakes now is preparing himself for that new challenge. If you want to aim for the stars, you must remember that you are building your launch pad right now, by your willingness and initiative in every task you tackle...at home, at church, in school and in Scouting.

SCCC POW WOW 2002

#### STAR WARS CLOSING

Cub Scouts have large cards spelling out STAR WARS. As each one steps forward, he holds up his card and says his line:

**S** stands for seek. Seek the mysteries of the future.

**T** stands for Top. Top the obstacles of youth.

**A** stands for Advance. Advance in the Cub Scouting program.

**R** stands for Reap. Reap the fruits of your labors.

**W** stands for Watch. Watch for imperfections.

**A** stands for Attack. Attack you shortcomings.

**R** stands for Reach. Reach for the sky.

**S** stands for Shoot. Shoot for the stars.

**All:** And may the force be with you, all the days of your lives.

#### AIM FOR THE STARS- Cubmaster Minute

The words "Aim for the Stars" have important meaning to Cub Scouts. There have been many before us who have set their sites and lived their lives by Aiming for the Stars. And while they may not have made it on the first try, or the second, or even the third, they eventually do make it.

A Cub Scout who does his best like our motto says, is bettering himself. Sure, sometimes he may not "hit the stars," but he grows from his trying. He is preparing himself for greater attempts and for great successes.

Remember, not everyone makes their goals every time, but we all make the world a better place by doing our best and Aiming for the Stars. And isn't that what our real goal is in life?

# TIME IN A CAPSULE September 2004 TIME IN A CAPSULE September 2004

## After the Meeting

### MOON ROCKS

*Makes 2 dozen*

Prep Time: 20 minutes

Cook Time: 20 minutes

Ready in: 40 minutes

#### *Ingredients*

- 1 cup semisweet chocolate chips
- 2 cups all-purpose flour
- 1 ½ teaspoons baking soda
- ½ teaspoon salt
- ½ cup butter, softened
- 1 ½ cups packed light brown sugar
- 3 eggs
- 1 teaspoon vanilla extract
- 1 cup water
- 2 cups miniature marshmallows



#### *Directions*

Preheat oven to 350 degrees F (175 degrees C).

Melt chocolate in the top of a double boiler. Let cool.

In a mixing bowl, combine flour, baking soda and salt. In a separate bowl, cream butter and sugar together. Blend eggs into the butter mixture one at a time. Stir in vanilla, flour mixture, water and chocolate into the butter and eggs; beat well. Stir in marshmallows. Fill paper-lined cupcake pans half full.

Bake in a preheated 350 degrees F (175 degrees C) oven for 20 minutes. Cool on a wire rack before serving.

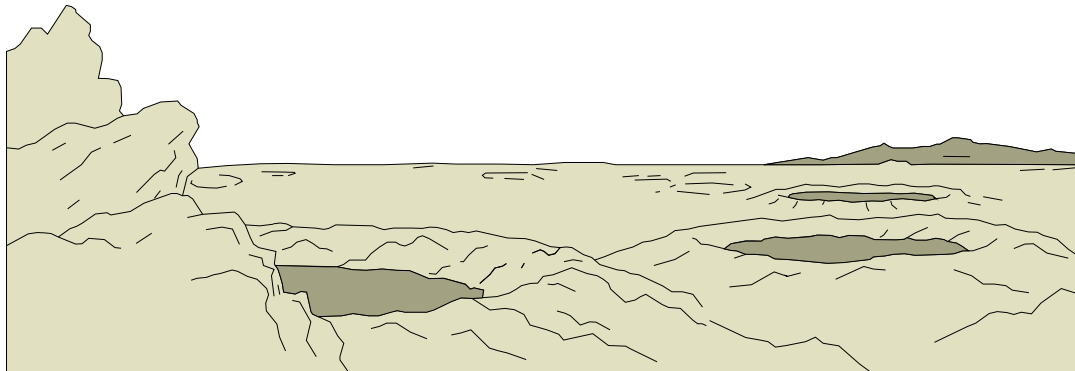

# TIME IN A CAPSULE

## September 2004

### After the Meeting

#### **ASTEROIDS**

For safety, Den Leader or Parent volunteers should help

#### Ingredients:

Potatoes -- Enough to make 4 to 8 cups of mashed potatoes. You can use frozen mashed potatoes. Or you can use fresh mashed potatoes (takes about 5 pounds to make 6 cups of mashed potatoes). Or you can use instant mashed potatoes. (Just don't make them too soft.)

1 cup grated cheddar (or other kind) cheese

Note about the cheese: The cheese will make the asteroids more delicious, but when it melts, the asteroids might go flat. If you want more realistic asteroids that don't taste quite as interesting, leave out the cheese.

1/4 cup (1/2 stick) of butter or margarine

Salt and pepper, as you like it

Extra butter or margarine to grease the cookie sheet and, if you like, to melt over the hot asteroids before you eat them.

#### Utensils:

Depending on how you make your mashed potatoes, you might need a pot and a potato masher or electric mixer

Mixing bowl and spoon

Oven mitt or pot holders

Cookie sheet

#### Directions:

Turn on your oven to 375° Fahrenheit (190 Celsius).

Take a little slice of the butter or margarine and rub it evenly on the cookie sheet so the asteroids won't stick. (You might want to use a paper towel for this so your fingers don't get all messy--yet!)

Make the mashed potatoes. Make a lot (8 cups) or a little (4 cups).

Add the cheese (if you want), butter, salt and pepper to the potatoes and mix well. The mixture should stick together. If it's too dry, add a little milk. If it's too moist, add a little flour (start with 2 tablespoons).

Take a handful of potatoes (about 1/2 cup or more) and shape it into your own idea of an interesting asteroid shape. Use your fingers to poke dents in it for craters. Set the asteroid on the greased cookie sheet.

Use all the potatoes to make asteroids. (If you have lots of asteroids, you may need another cookie sheet. Or bake the first ones, then regrease the cookie sheet and make some more.)

Put the cookie sheet full of asteroids in the hot oven for about 20 to 25 minutes, or until they are brown.

Using the hot pads or oven mitt, remove the cookie sheet from the oven, and using the large spoon, transfer the asteroids to a serving plate.

# TIME IN A CAPSULE

September 2004

Communicator

## COMMUNICATION CODES

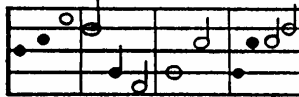
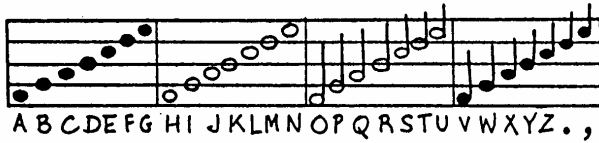

SOLUTION

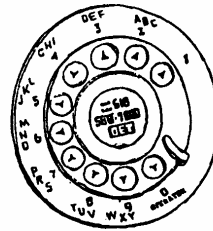

**TELEPHONE NUMBER.** This is a secret message game based on a rotary telephone's dial. Give each boy pencil and scrap paper and ask him to convert a very short message into code based on the dial numbers. It's tricky because there is a choice of three letters for each number. Here's a sample message:

36 DO  
9687 YOUR  
2378 BEST

When each boy has coded his message, exchange papers and have the boys try to solve others' messages.

### TIC TAC TOE CODE

DRAW A TIC TAC TOE GRID AS SHOWN. REPLACE EACH LETTER IN THE ALPHABET WITH A DOT. USE THE DOT AND PIECE OF THE GRID TO REPRESENT EACH LETTER.

A	J	S	.	.	.
B	K	T	.	.	.
C	L	U	.	.	.
D	M	V	.	.	.
E	N	W	.	.	.
F	O	X	.	.	.
G	P	Y	.	.	.
H	Q	Z	.	.	.
I	R	?	.	.	.

J J J J J J J J J J  
 A B C D E F G H I J K  
 U O O O P P P L L L E  
 L M N O P Q R S T U V  
 E E F F F  
 W X Y Z ?

### COMMUNICATION WITH A COAT OF ARMS

HUMOR	APPETITE	SINCERITY	PEACE	COURAGE	WISDOM
WARRIOR				STRENGTH	
RELIGION				HONOR	
PRIDE				CLEVERNESS	
EAGERNESS				ACHIEVEMENT	

# TIME IN A CAPSULE

## September 2004

### Communicator

#### COMMUNICATION CODES Continued

**MORSE CODE SIGNALER.** Materials: long, business-size envelope (4 1/2" x 9 1/2"); piece of lightweight cardboard, 4" x 10"; black felt-tip marker or crayon; scissors.

This trainer will help your Webelos Scouts master the Morse code. First, with the envelope front facing you, snip off the right end close to the end. Mark the centerpoint of the front of the envelope three inches from the left end. Cut out a three-inch-diameter circle centered on the point just marked. Caution: Only cut through the front of the envelope.

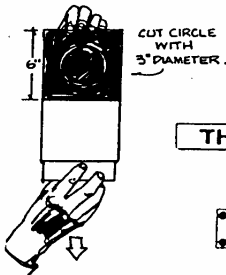

Now push the cardboard slide into the open end of the envelope until it stops. With the black marker darken the entire left front of the envelope from the far left end for six inches to the right. Remove the slide and completely darken it for 4 1/2 inches from the left end. Seal the flap.

Replace the slide. On the rear of the envelope write the entire Morse code (see the Boy Scout Handbook). Hold the device with the hole facing the receiver. Hold one upper corner of the envelope. With the other hand hold the bottom of the slide. Pull the slide down so it uncovers the white portion of the inside rear of the envelope (thus making it appear as if you are shining a light toward the receiver. For a dot, pull the slide clear of the circle for one second; for a dash, three seconds.



#### THESE LETTER GROUPS WILL HELP YOUR CODE PRACTICE

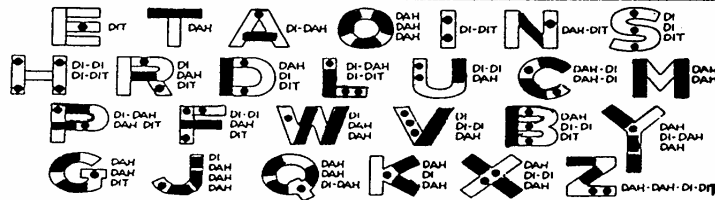

**"COMMUNICATIONS" GAME - FOR LEADERS ONLY**

Six very important words : "I admit I made a mistake"

Five very important words : "You did a good job."

Four very important words : "What is your opinion?"

Three very important words : "If you please."

Two very important words : "Thank you."

The least important word : "I."



# TIME IN A CAPSULE

## September 2004

### Communicator

#### OTHER KINDS OF COMMUNICATION

Another way we communicate is to mark something in a certain way to show ownership or a relationship. Your last name indicates that you are part of a family and related to others with the same name. Even names are "codes" of a sort. The blacksmith sometimes became known as SMITH and his son would be SMITHSON. Take a phone book and see if you can guess how a name may have come about.

#### INTERNATIONAL SYMBOLS

Have the boys write what each sign means



- |                     |                     |                    |                       |
|---------------------|---------------------|--------------------|-----------------------|
| 1. No U-turn        | 2. No bicycles      | 3. Tent site       | 4. Hotel, motel       |
| 5. Boat ramp        | 6. Forest           | 7. Restrooms       | 8. Wet floor          |
| 9. Trash can        | 10. First Aid       | 11. Red Cross      | 12. Animal Crossing   |
| 13. Handicap Access | 14. Wildlife Refuge | 15. Magnetics      | 16. Shower            |
| 17. Information     | 18. Campsite        | 19. Child Crossing | 20. Fasten Seat Belts |

# TIME IN A CAPSULE

## September 2004

### Communicator

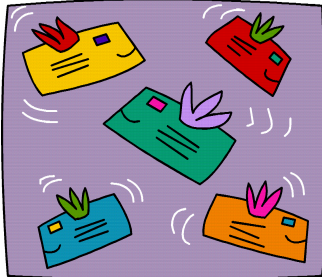

Communication is one of the most important skills that the Webelos Scout will use during his life. He will communicate every day with other human beings, and possibly with animals. We often consider communication as the expression of our thoughts or feelings through speech, gesture, print, and electronic devices. Communication, however, really is comprised of both the transmission of the message, and decoding by the receiver. In other words, communication does not exist unless the message is both sent and received. When the intended recipient of the communication understands the

message, then the communication is effective. Learning to communicate effectively will help us all now and in the future.

### **BITS and BYTES**

Where does the information go when you delete things on your computer?

Computer hard disk drives have an arm that moves back and forth over a spinning disk. At the end is an electromagnet that is turned on and off. That can flip the molecules of the disk – a magnetic material. It arranges the molecules. The arrangement can be read later by scanning the disk with the same arm. Each bunch of molecules is called a BIT. Groups of them are called BYTES. This drawing is an 8-bit byte. As the molecules flip over, they represent a 1 or a 0. The north magnetic pole is 1, the south is 0. Digital storage always involves just 2 values; 1's and 0's, or on and off. Our drawing is the number 10010110. If we use a special number system called binary numbers, these 8 bits store the number as 140.

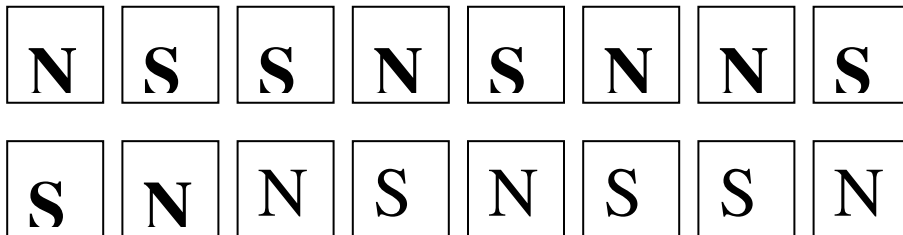

Stuff stored in digital code makes up files or documents. They are stored in little zones or sectors on a hard disk. Most of the time files are too big to fit in just one continuous line of sectors, so the files get spilt up. The first part of a file is called the header. In the header are things like the name and date of the file and also the size of the file, and a really important piece of information – which sectors the file is stored in. That information tells the arm where to scan for the data. Without the header the data is left in chunks all over the disk. When you delete a file what you're really



# TIME IN A CAPSULE

## September 2004

### Communicator

#### **BITS and BYTES Continued**

doing is just erasing the header. The file's data is still there. It just doesn't have an address anymore. Eventually it will be written over by new data

Information on a computer is not stored as matter or energy; it's stored by arranging matter. The computer uses energy to make the arrangement, to read the arrangement or to delete the arrangement. That energy is converted into heat, which is why there are fans in computers.

#### **COMMUNICATOR ROUND ROBIN SKIT**

Arrange boys in a large circle. Give each one a communications transmitter of some kind, such as a flashlight for Morse code, the string and can telephone a boy's hands for sign language or a tom-tom for drumbeat.

Give the first boy a message to transmit, written on a piece of paper. Each boy in turn tries to relay this message to the next boy in line using his signaling device. (Remember your boys are just simulating this, not really doing it.)

The last boy writes down the message and comes up to stand beside you. You read your message, which is "Mr. Watson, come here I need you". The boy is then asked to read his message, which is "The number you have reached is out of service or you have not used the correct area code. Please hang up and try again. If you think you have reached this recording by mistake..." About halfway through this speech. Put you arm on the scouts back and begin guiding him off stage, shaking your head

#### QUIET ACTIVITIES

##### **Message coding**

Use the Morse code table found in the Webelos Scout Book, Communicator section to encode a short message. Each boy should keep his message short, one sentence of 5 - 8 words, and not let other boys see it. Then let them trade messages and try to decipher them.

# TIME IN A CAPSULE

## September 2004

### Communicator

#### TIE SLIDE

##### Tin Can & String

*Materials: 1 dowel rod  
String  
Silver paint or markers  
Horseshoe nail  
Glue  
Hammer*

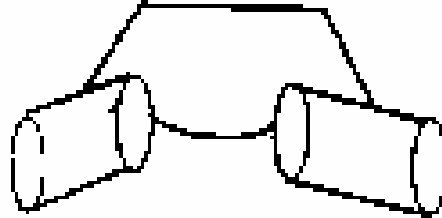

#### DIRECTIONS

Cut dowel to desired size (remember this is going on their necks)  
Paint silver to look like cans  
Put one can on each end of the horseshoe nail  
Glue the string between the cans as shown. Allow the string to hang loosely

#### FIELD TRIPS

Newspaper office  
Radio Station  
TV Station  
Telephone Office  
Commuter Center

#### Word of caution:

Most of these communication centers are very security conscious, so do not be surprised or disappointed if they tell you they do not allow groups to tour.

#### DEN ACTIVITIES

Trace the history of communication in a chronological order, starting with the early communication, method of sign language.

Demonstrate the spoken word by having boys hold their hands over their larynx to feel the vibration, and make an old fashion can and string telephone. Be sure to keep the string taut and not touching anything.

Use thick twine 10 - 20 feet. Make a hole through the middle of each can

with a medium size nail. Wash can thoroughly. Pull the string through each nail hole. Tie a large knot in string on each end. To use simply hold can by its side, keeping string taut. Put to mouth to talk, to ear to listen.

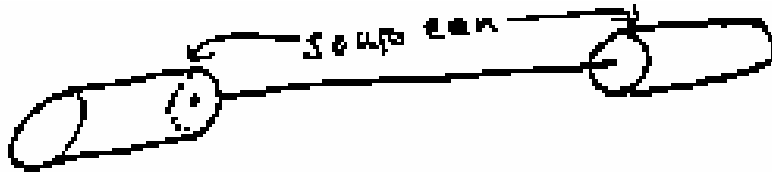

# TIME IN A CAPSULE

## September 2004

### Communicator

#### DEN ACTIVITIES continued

1. A telegraph key will demonstrate Morse code. Use the key to open and close a circuit made up of a tone buzzer and a battery. You can make the key or "bug" out of a spring clothespin if you wish.
2. Invite a member of the Rotary Club or the Toastmasters International to visit your den and give examples of body language.
3. Visit a meeting of these organizations to observe how communications is given
4. Ask a member of the local amateur radio organization to visit your den or allow the den to visit his base station to see how communications is arrived using the International Morse Code.
5. Listen to a CB radio or find an active Citizen band Radio Club in your area to tell your den how the radio can help.
6. Visit the local library or your school library to find out how the books are indexed to locate them easier.
7. Local radio stations or television stations can show your den how they receive communications from around the world through the use of micro transmitters or satellite stations.
8. Communications can be carried out in many forms. Try to locate the local organization that teaches the deaf to sign and see if they might be willing to teach the den a few basic words or phrases.
9. Find out if one of the Dads in the den has his own personal computer and see if he is willing to show each of the boys how it works and allow them to access the computer base.
10. To find out the many job opportunities in the communication field, check with the local Chamber of Commerce to locate companies that use communication as a basis for employment in your area.

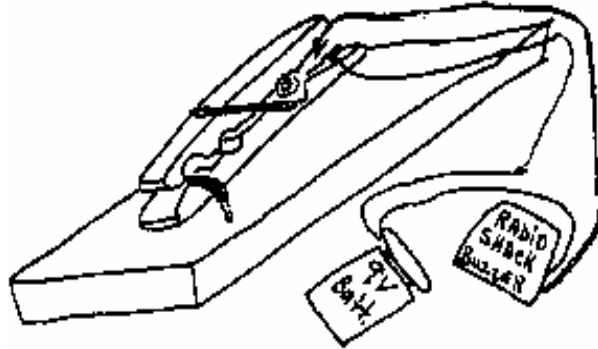

# TIME IN A CAPSULE

## September 2004

### Communicator

#### KIM'S GAME IN THE DARK

Out of sight of the immediate area, attach a line zigzagging between trees or stationary objects. Tie objects to the line along the way. Ten items is a good number. Blindfold each Webelos Scout and lead him to the rope. Boys then proceed down the rope, holding on and remembering the objects they come across. No talking is allowed. When each boy reached the end of the rope, the leader takes him out of sight of the course and removes his blindfold. Boys may work individually or as group to see how many objects they can identify and remember.



#### SPARTAN SCYTALES

This is one of the oldest methods of communicating messages. Spartan generals exchanged information using twin cylinders and strips of parchment. The sender would wind the parchment around his cylinder, or scytale, and write the message in several horizontal lines. Then he would unwind the ribbon, the letters of the message appeared out of sequence. Only the person with the matching cylinder was able to rewind the parchment and restore the original sequence of letters.

**Supplies:** 2 pieces of dowel, each 3/4" - 1" in diameter, 10 - 12" long  
2 thumbtacks  
Ribbon or paper strips, 1/4" - 1/2" wide. 2 feet long  
Felt tip pen

#### DIRECTIONS

Gently hammer a tack part way into one of the cylinders about 1/4" down from the top. Do the same to the second cylinder.

Write your secret code name on one cylinder. Give the other cylinder to your partner.

To send a message, remove the tack from the scytale. Stick the tack through the end of the ribbon and re-insert it. Wrap the ribbon around the scytale in close spirals. Hold or tape the bottom end in place. Write your message in horizontal lines. Take the ribbon off and send it to your partner.

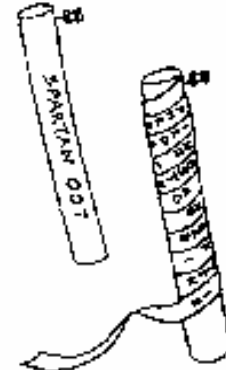

To decipher the message, do the same thing you did to write the message.

# TIME IN A CAPSULE

## September 2004

### Communicator

#### **SOUND EFFECTS GAME** - Good pack meeting demonstration!

This game is identifying sounds. The den chief or den leader produces sounds from behind a screen or in another room, and the Webelos listen. Boys try to identify each sound.

Sample sounds met be -- ping pong ball bouncing on floor, sanding a piece of wood, shuffling a deck of cards, breaking a twig or stick in half; pushing buttons on telephone, sawing wood, etc.

*Webelos Scouts could work in the Communicating and Computer Academic belt loops and Pins in conjunction with this activity badge.*

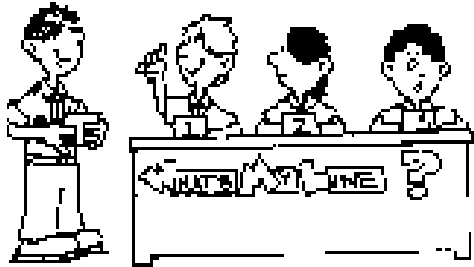

#### **WHAT'S MY LINE** - a take off on the old game show

Let 2 or 3 boys tell a story about a similar situation, with facts a bit different in each version. One is telling a true story, the others are not. The rest of the den takes turns asking the panel questions to determine who is telling the real story. After telling their initial tales, all boys on the panel must answer all questions truthfully, even if the

answers contradict their original story, so that the rest of the den can determine the truth teller.

#### **CLOTHESLINE TALES**

Give boys a general topic and have each one of them draw a picture about anything to do with that topic (such as "Space Aliens") String a clothesline up between two trees. Have first boy come up, hang picture and begin to tell a story about his picture. After one minute, stop him, have the next boy come and continue story with his illustration. Continue until all boys have shared and a brand new story has been communicated to the den!

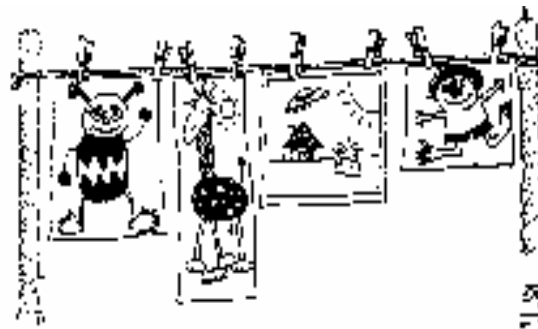

# TIME IN A CAPSULE

## September 2004

### Citizen

One of the purposes of Cub Scouting is "Developing habits and attitudes of good citizenship". A Scout promises to do his duty to his country. The Citizen Activity Badge helps the WEBELOS understand what a good citizen is and teaches him the history of our flag. Citizen Activity Badge is in the Community group.

### OBJECTIVES

To foster citizenship in WEBELOS Scouts. To teach boys to recognize the qualities of a good citizen. To introduce boys to the structure of the U.S. government. To familiarize boys with basics of American history. To convince boys that laws are beneficial. To encourage WEBELOS Scouts to become community volunteers.

### Where to go and what to do

Invite a guest speaker from a local board to explain his duties and tell the WEBELOS Scouts why he volunteers his time.

Buy a packet of used U.S. commemorative stamps. Distribute several to the WEBELOS Scouts and challenge them to discover the "story behind the stamp". At the following meeting allow each boy ample time to describe his stamps and their significance.

Attend a local city council meeting.

Do a Good Turn by conducting a litter pickup campaign.

Have each WEBELOS Scout write a letter to his Senator or Congressman to express an opinion on an issue. It would be especially interesting if two WEBELOS Scouts wrote an opinion about opposite sides of the same issue. See what responses you receive.

Encourage WEBELOS Scouts to fly a flag at home particularly on appropriate flag holidays.

Arrange for the WEBELOS den to do a community service project.

### Good turn ideas

Give some of the toys the WEBELOS Scouts may have made as part of the Craftsman badge to needy children. Use Craftsman skills to repair and refurbish toys for the same purpose.

Give a holiday party for children or adults in a residential situation. Plan games, songs, small gifts, party favors, and treats.

Participate in the Food Drive in the fall to stock good pantries for needy families.

Collect toilet articles and used clothing for the homeless.

Salvage used books to be sold at the public library or to be used to set up libraries for children or adults in a residential situation.

Read to someone who cannot see.

Provide snow shoveling, yard care, errand service, or other aid to an elderly person or couple in your neighborhood.



# TIME IN A CAPSULE

## September 2004

### Citizen

**NEWSPAPER STUDY GAME** - for dens or small groups

Equipment: One current newspaper per den

Teams gather in groups, each with the same day's issue of a newspaper. On signal, teams start a search for news items that definitely illustrate the 12 points of the Scout Law.

Items are cut out and numbered according to the point of the law. Team with the most clippings in a given time wins.

Strategy Tip: Team leaders should distribute pages among his team members instead of everyone grabbing for papers.



### CITIZEN SCAVENGER HUNT

By Barb Stephens

Most government buildings offer a tour of some sort and you might be able to combine the tour with the following scavenger hunt. Divide the den into two or three teams and give the boys a reasonable time limit. Have them locate answers to questions like these:

1. What is the mayor's middle initial and what does the initial stand for?
2. Bring back a piece of stationery showing our town's logo or crest.
3. Draw a picture of our state flag.
4. On what floor of City Hall can you find \_\_\_\_\_?
5. Who runs the Water Works Department and what does that department do?
6. Where does the City Council meet?
7. What's on the top floor of the City Hall building?
8. What is the full name of the governor of the state?
9. Get a brochure about trash pick up service.
10. Who takes care of snow removal/tree removal from city streets and what is their budget?

# TIME IN A CAPSULE

## September 2004

### Citizen



#### DO YOU KNOW YOUR FLAG?

When the Stars and Stripes first became our national flag, no one was sure just what the design of the flag should be. Since the time of that first flag, official descriptions of the national colors have been very careful and clear. Not only is the design of the flag carefully described today, but there are many special rules for displaying it. The following questions are based on the universal flag code of the United States. See how many you and your WEBELOS den can answer correctly. Some of these questions are tricky.

The flag is raised (a) slowly; (b) briskly; (c) at any speed that is comfortable.

If you carry the flag in a parade and passed before the President of the United States, you would dip the flag slightly in salute to the President as you walked past him. True or False?

The flag must never be lowered no matter how bad the weather conditions. True or False?

The flag is never allowed to fly after daylight hours anywhere in the world. True or False?

When the flag is carried in a procession or on other occasions, it is escorted by an honor guard. True or False?

The flag's honor guard walks (a) on the flag's right; (b) just behind the flag; (c) on both sides of the flag.

If you are a Cub Scout, WEBELOS Scout, Boy Scout, or Explorer, you always give the Cub Scout, or Explorer salute to the flag even when you are not in uniform. True or False?

When you carry the flag in a parade with other flags, the U. S. flag must go on the left of and in line with the other flags. True or False?

Answers:

(b) briskly - it's a happy occasion!

False. The flag is never dipped to anyone..

False. The flag is not flown in bad weather.

False. Although it is the custom to display the flag only from sunrise to sunset, there is not law prohibiting its being flown both day and night.

True.

(c) on both sides of the flag.

False. When you are in civilian clothes, you remove your hat and place your hand over your heart when the flag passes

False. It is carried at the right of the other flags or at the front and center of a line of other flags.

# TIME IN A CAPSULE

## September 2004

### Tigers - Fun at the Zoo Family Activities

Zoos are a great choice for family fun anytime, with events and fun year-round. Your family can see some of nature's most beautiful and varied creatures, and learn about their favorite animals.

#### **VISIT THE ZOO**

Get a family pass to the zoo. If the whole family visits the zoo just twice, you more than recover our cost.

#### **WALKING IN THE ZOO**

See how animals look with their winter or summer coats on. Talk about how they live in either the cold or hot weather.

### **Den Activities**

#### **SPONGE PAINT GIRAFFE**

Author Unknown

Need: Orange paper in the shape of a giraffe, black paint, small sponges or cotton balls, clothes pegs, Styrofoam meat tray

Directions: Use the clothes pegs as handles and attach a cotton ball or sponge to the end. Put the paint on a Styrofoam meat tray and using the cotton ball/sponge to dip into paint and dab spots onto the giraffe.



#### **ZEBRA**

Author Unknown

Need: Zebra shape, marble, black paint, box

Directions: One of my favorite zoo animal activities is to roller ball paint (marble paint) on a zebra shape with black paint. I use the boxes that canned coke come in to do this activity. I simply supply the black paint in a shallow pan, the zebra cut outs, and large marbles.

#### **ZOO CAGE**

Author Unknown

Need: Shoe box, straws, clay or toilet paper rolls

Directions: Take a shoe box-remove lid- punch holes about 1/4 of inch in along the length of the box and again on the paralleled side trying to keep holes aligned. Run a straw through a hole on the top and on the bottom -sit box onto one of longer side wha la cage. Next allow the children to create an animal out of clay or toilet paper rolls. Pull up a straw and give the animal a home.

# TIME IN A CAPSULE

## September 2004

### Tigers - Fun at the Zoo/ Pet Care Den Activities

You can find more ideas at [zoopals.pactiv.com](http://zoopals.pactiv.com)

#### **Make a puppet.**

Glue or tape a stick to the back of a Hefty® Zoo Pals® plate and make a puppet for a puppet show. You can use a Popsicle stick, paint stirrer, ruler, or even a chopstick. You can put on a show, such as a make-believe zoo or circus, or take the animals on an adventure.

#### **Make a mask.**

Glue or tape a stick to the back of a Hefty® Zoo Pals® plate. Cut out the eyes and let the child hold the animal face up to his/her face. To ensure that the child does not trip or fall, use the mask only while seated.

#### **Make a set of animal ears.**

This is great for a costume or for letting your child pretend to be his/her favorite animal. Cut your child's favorite ears off the plate about ½ inch below the ears. Tape the ears, at the center only, to a plastic, rigid or cloth headband and carefully place ear-band on child's head. See if your child can make the sound or motions of his/her favorite animal.

#### **Design your own Hefty® Zoo Pals® plate.**

Turn a plate upside down on a piece of paper. Trace the outline of the plate to form a template for a new animal design. Let your child draw his/her own Zoo Pals® animal with crayons, markers, or paint. Or cut apart the pieces from real plates and let the child paste together a new plate, combining eyes, noses, and ears from different animals. Create a body for your favorite Zoo Pal® animal. Select your favorite Hefty® Zoo Pals® plate and glue or tape it to a large piece of paper. Let your child design a body for his/her favorite animal using crayons, markers, paint, or even scraps of fabric.

#### **Jazz up Hefty® Zoo Pals® plates.**

Use glitter, fabric scraps, yarn, paint, nail polish, and colored glue to decorate and accessorize your favorite animals. Give them hair, glasses, shoes, and more.



# TIME IN A CAPSULE

## September 2004

### Cubmaster Corner - Boy Discipline and Behavior

#### **What is Behavior?**

A behavior is anything that a child actively does that can be observed and measured. If you can see a child do something, then it is a behavior. Most active behaviors that can be seen can be changed with a consistent behavior management program. However, it must be seen or measured. This sounds simple, but it can be tricky. There are a few rules that go along with defining a behavior. These rules are as follows:

#### Rule 1:

If a dead person can do it, it is not a behavior. For example, to sit is not a behavior to work on. Or to be quiet is not a good behavior to use in a behavior management program. Non-movement is not a behavior to work on. You should be concentrating on active behaviors that can be seen or measured. not "dead" movements.

#### Rule 2:

If it is assumed to be inside the child, but can not be seen, it is not a behavior. An example is the child has a bad attitude. Attitudes are not seen. Only behaviors which can be seen or heard such as talking back, having an angry face, or yelling are behaviors to work on. To concentrate on a bad attitude will not change behaviors without concentrating on the behaviors themselves.

#### Rule 3:

If it is merely a label for something, but it can not be seen or measured, it is not behavior. For example, I want John to be more responsible. No one has ever seen responsibility. Behaviors that are generally (1) done on time, (2) up to a competent standard, and (3) done without a prompt are considered responsible. Getting to work on time on a Monday morning ready for work without the boss having to call and remind you would be considered responsible. However, to concentrate merely on responsibility would be a mistake. Behaviors have to be defined.

#### **Specific and Positive Behaviors are Best:**

Not only should the behaviors be active, observable, and measurable, they should also be specific. Behaviors that are defined in clear terms, countable, and even broken into small steps are best.

Most youth leaders want to decrease unwanted behaviors, such as arguing, talking back, fighting or noncompliance to requests. These are important, However, to only reduce behaviors is a mistake. That would leave a vacuum. Once a behavior is reduced it should be replaced by a positive behavior that can be built into a good habit.

#### **Reinforcers and Rewards:**

People do most of their behaviors because they get something for doing them. This may sound mercenary, however, it is true. A leader spends extra time helping a boy because they are rewarded by the idea that helping is good. A person may serve a vegetable tray for a snack, because he is reinforced by the idea that it is healthy for those who eat them. How many people would continue to go to work if they did not feel they received something in return for their efforts?

# TIME IN A CAPSULE

## September 2004

### Cubmaster Corner - Boy Discipline and Behavior

#### **Reinforcers and Rewards Continued:**

Children having difficulty, are particularly helped by small rewards that are systematically given for appropriate behaviors. These rewards are often referred to as reinforcers. A reinforcer is any reward that will increase or maintain a behavior. Reinforcers can be: SOCIAL - ACTIVITY- MATERIAL.

People often think of material things, such as candy, stickers, and toys. When they think of rewards for children. However, it may be surprising to realize that if a child continues the misbehavior when yelled at or scolded, then yelling and scolding are positive reinforcers. The child is getting your attention. This is a common problem. Youth leaders (like parents) may assume that yelling and scolding are negative, but if the behavior increases or continues, then they are giving the child positive reinforcement. In his eyes he has your attention it doesn't matter that it's yelling.

The GOLDEN RULE selecting a reinforcer for a child is:

The reinforcer should not cost a lot of money, nor take a lot of time, and it should be natural (anything that kids may receive anyway, such as extended game time). It should be something the leader feels comfortable giving. Also, in group situations it should be something all group members can participate in. To select a menu of reinforcers for a child, do the following:

Ask the child, by simply asking a child or group of children a leader can get a reinforcement list.

Watch the child. What a child chooses to do most of the time is more reinforcing. Give the group opportunities for "free choice" activities from a prepared list of choices.

Record what the child/children often ask to do or get. These are the most reinforcing (example: a certain game, treats, and craft).

#### **Reinforcing expressions:**

Smiling, nodding, winking, looking, raising eyebrows, widening eyes, applause, shaking hands, thumbs up, signaling "OK", encouraging comments (Positively, excellent, perfect, fantastic, good response, totally awesome, cool, sweet, fine answer, nice try, wonderful job, etc.)

#### **Reinforcing statements:**

I appreciate your attention  
That's a good point  
That's a big help to the group  
You should be very proud of yourself  
That was a good choice  
You're a great participator  
I'm glad you are here



# IT'S A CIRCUS OF STARS

## October 2004



Ladies and Gentlemen welcome to the Cub Scout Circus. It will be a month of entertainment. Dens will practice stunts, skits, songs, run ons and applause's as part of their advancement -- and just for fun as they prepare to share their talents at the monthly pack meeting. The pack meeting focus will be the magic of a circus, with the Cubmaster serving as ringmaster. The pack meeting may be set up with three rings where each of the dens performs what they have been practicing. Be sure to have lots of balloons, peanuts, and popcorn for the audience, as well as spotlights on each den as they participate. Awards could be presented in each ring.

Cub Scout Theme .....	03
Webelos – Showman .....	16
Webelos – Citizen.....	19
Tigers - Magic Fun .....	24
Cubmaster Corner - Ceremonies and Training.....	26

# IT'S A CIRCUS OF STARS

## October 2004

### The Little Dash

I read of a man who stood to speak  
at the funeral of his friend.  
He referred to the dates on her tombstone  
from the beginning...to the end.

He noted that first came the date of her birth  
and spoke of the second with tears,  
but he said that what mattered most of all  
was the dash between those years.

For that dash represents all the time  
that she spent alive on earth,  
and now only those who loved her  
know what that little line is worth.

For it matters not, how much we own;  
the cars, the house, the cash.  
What matters is how we live and love  
and how we spend our dash.

So think about this long and hard,  
are there things you'd like to change?  
For you never know how much time is left.  
(You could be at "dash mid-range.")

If we could just slow down enough to consider  
what's true and what's real,  
and always try to understand  
the way other people feel.

And...be less quick to anger,  
and show appreciation more  
and love the people in our lives  
like we've never loved before.

If we treat each other with respect,  
and more often wear a smile,  
remembering that this special dash  
might only last a little while.

So, when your eulogy is being read  
with your life's actions to rehash...  
would you be pleased with the things they have to say  
about how you spent your dash?

--From circle Ten Pow Council, Author unknown



# IT'S A CIRCUS OF STARS

## October 2004

### Gathering Activities

#### GRAB BAG CREATIONS

Give each den a bag full of odd stuff, a bottle of glue and see what they can make!

[from Karla Hogan, Pack 44, Central City]:

We used this for a pack meeting change on short notice. We were supposed to go on a hayrack ride and it was too cold. Each Den Leader was to bring several items in lots of 7, since we have 7 dens. The leaders came up with great ideas from their own stock of supplies.

We included stuff like

- construction paper
- toilet paper rolls
- paper towel rolls
- beads
- packing peanuts
- yarn
- tooth picks
- plastic milk lids
- feathers
- pipe cleaners, felt
- craft sticks
- pop tops
- tongue depressors
- tooth picks
- plastic milk lids
- feathers, pipe cleaners, felt
- pop tops
- tongue depressors
- craft sticks
- spools
- paper clips
- spools
- paper clips
- Velcro pieces
- Rick-rack,
- small pieces of wood,
- bells,
- string,
- buttons,
- margarine tubs,
- and anything else you have enough of.

Have a pile of grab bag stuff that you don't want to separate into the bags or didn't have enough of to give to each boy or make a complete project.

Each group got to go to the grab bag and select items that they needed. This was done on a rotation basis and each group got to pick two things. Divide the groups by den. The leaders were allowed to help, just go around and provide positive comments to all the groups. Set a time limit and then put the items made in a central location. Then you can play games or if providing food you can eat. While play the games or eating the leaders judged the final works of art.

The awards were Cub Scout pencils.

Each group got an award i.e.

Most Useful

Most Creative

Best Use of Materials

Most Related to Scouting, etc.

It's a lot of fun and gets the parents very involved with the dens. It makes a great last minute pack meeting on short notice.



# IT'S A CIRCUS OF STARS

## October 2004

### Openings

#### **C-I-R-C-U-S**

*PERSONNEL: Six Cubs or Leaders dressed as clowns carrying balloons, each with a letter in CIRCUS on it.*

**C** - Come and watch what we have in store.

**I** - Including fantastic acts never seen before.

**R** - Roaring lions may fill you with fright.

**C** - Clowns will be making you laugh all night.

**U** - Using the Pledge of Allegiance for our show to begin.

**S** - Stand now together as our flag is brought in.

#### **C-L-O-W-N**

*PERSONNEL: Five Cub Scouts enter, dressed as clowns, holding posters with large letters and sayings on back.*

**C** - C is for Cub Scouts - Cub Scouts like to laugh and to have fun.

**L** - L is for Leaders - Leaders are there to show, teach and to help.

**O** - O is for Opportunity - An opportunity to have boys laugh with you rather than at you.

**W** - W is for Webelos - Webelos are older Cub Scouts that also like to laugh and have fun.

**N** - N is for nothing - Nothing in the world has more learning and laughter and fun than Cub Scouting.

#### **CIRCUS FLAG CEREMONY**

*The Pack Meeting is set up and run like a world class circus. The Cubmaster is attired as Ringmaster; all Cub Scouts are in costumes*

Ringmaster: Ladies and Gentlemen, boys and girls, welcome to our show "Under the Big Top!" Let's greet our circus performers as they make their grand entry by standing and singing the Star Spangled Banner.



Play snappy recording of the National Anthem as flags and color guard lead the parade. All Cub Scouts are in their den-made costumes as clowns, side show members, aerial artists, trained and wild animals. Use brilliant colors, fantastic costumes and masks with a lot of imagination. Have trilling circus music, capricious clowns (den leaders) fill in slack time between the den circus acts of your show. [www.scoutxing.com](http://www.scoutxing.com)

# IT'S A CIRCUS OF STARS

## October 2004

### Openings

#### CIRCUS THEME

- 1<sup>st</sup> Cub: The circus is our theme for this month; we think it is a dilly;
- 2<sup>nd</sup> Cub: Both circuses and little boys can sometimes be quite silly.
- 3<sup>rd</sup> Cub: Den leaders find it a natural to do this kind of show.
- 4<sup>th</sup> Cub: They run a three-ring circus every single week, you know.
- 5<sup>th</sup> Cub: At a circus there is shouting, roaring, stamping, whistles tooting;
- 6<sup>th</sup> Cub: Tumbling, pushing, falling, wrestling, and a rolling and a-rooting.
- 7<sup>th</sup> Cub: At den meetings things keep moving, constant motion, constant noise.
- 8<sup>th</sup> Cub: There are lots of things in common between circuses and boys.
- Den Chief: We've put all the dens together; it's not Ringling Brothers, you know.  
But we think you will enjoy it, so let's get on with the show

# IT'S A CIRCUS OF STARS

## October 2004

### Den Activities

- Discuss the big top and animals: bears, elephants, tigers, and lions. There are clowns, man on the flying trapeze, center ring, and shooting from the cannon.
- Discuss how the circus travels from place to place, each time setting up the big top, and then taking it down in a few days.
- Ask each boy to come dressed as their favorite circus performer.
- Have them come to the den meeting with a circus act that they will perform or part of the group can be dressed as lions and another as the lion tamer and do a pretend Big Cat Act - lions jumping through a ring (hula hoop). Give the lion tamer a top hat and a whip made from a long paper roll (rolls from gift wrap work well) with long crepe streamer stripes. Other Circus Acts might include a strongmen; flying trapeze; juggling; balancing. Have the boys pretend to be prancing horses (high stepping around the ring); bareback riders (doing fancy tricks); Circus Elephants (walking in line (tails to trunks), moving very slowly, balancing on a beam or "barrel"). Tightrope Walkers (arms out at side as they balance along a masking tape line on floor - doing one legged turns, bows, etc. Add the balance beam and an umbrella). Acrobats (forward and backward rolls, cartwheels, splits etc).
- Some of the boys could come as clowns and put on a skit (do clown like actions: running, jumping, falling, tripping over pretend objects, wiggling and all large exaggerated movements). Elephants balancing; Lions and Tigers (jumping or stepping through hoops, prowling around the cage - snarling and lunging at the trainer, jumping off "barrels" pretend wrestling with each other).
- They could practice their acts for the "Big Show" when perform them at Pack meeting.



During the den meetings:

- 1<sup>st</sup> week every scout must imitate a circus animal when asked to do so ONLY by the den leader.
- 2<sup>nd</sup> week every scout must make a clown face when asked to do so ONLY by the den leader.
- 3<sup>rd</sup> week every scout gives their best impression of the circus ringmaster when asked to do so ONLY by the den leader

# IT'S A CIRCUS OF STARS

## October 2004

### Crafts

#### SNOWCONE ART

Take a sheet of white cardstock and draw a v shaped cone on the page. Give the boys different colors of cotton balls and let them glue them at the top of the V to make a snow cone. Optional you could use tissue paper crumbled into a ball and then glue them on the page instead. Instead of a snow cone how about Cotton candy



#### POPCORN ART

Using colored cardstock give the boys popped popcorn and let them make a design of their own. Make plenty, as they will eat as they work!

#### PEANUT ART

Using raw peanuts in the shell and white glue let the boys create their own circus animals. Once the glue dries let the boys paint their sculptures with colored markers.

#### PAINTING WITH PEANUTS

Lay a white sheet of paper in a shallow baking pan or box lid. Dip three or four raw peanuts in different primary colors and lay them on their paper. Roll back and forth four or five times or until the boy has achieved his desired effect. .

#### CIRCUS BANNERS

Make circus banners, like the triangular ones you can buy at the circus. Children can decorate with stickers, sequins, glitter, etc.

#### CLOWN FACES

Give each child a white paper plate. Let the children paint a clown face, encouraging them to use many different colors of paint. When the paint is dry, glue on a red pompom for a nose. Add yarn for hair.



#### CLOWN SHOES

gummed paper reinforcements  
2 shoe boxes (clown shoes)  
2 60-inch lengths of ribbon or yarn  
colorful pompoms

Punch holes along the top of the boxes and glue the reinforcements over the holes for eyelets for the laces. Fold the front end of each shoe down into the box. Lace the shoes, Pull the laces firmly to pull in and fold down the sides. Tie laces in a bow. Decorate with pompoms.

# IT'S A CIRCUS OF STARS

## October 2004

### Crafts

#### MINI BALLOON BOUQUET

Paint (and optionally decorate) Ping-Pong balls. Glue each to the top of a straw. Tie curling ribbon streamers under Ping-Pong ball if desired. Place inside decorated soup can.

#### CIRCUS STARS

Blow up small balloons (5-6" diameter). Cut off the top 2" of a large plastic cup for the base. Tape the balloon, neck down, in the base. Make different animal/character heads by adding yarn hair, wiggly eyes, paper ears, noses, smiles, or magic marker accents. (Some ideas: elephants, bears, ringmasters, lions, clowns, seals, etc.)

#### CIRCUS TRAIN

Use empty Kleenex boxes (the kind with oval cut out are best) for various circus train cars. You can paint them or cover them with construction paper or leave them as is. Glue brightly colored cardboard wheels to the four corners. Draw and color various paper animals to put into each box. Add paper "bars" to keep the animals in. Don't forget to make the giraffe box open to the top!

#### CLOWN BOWS

Materials:

One 7X12 in. piece tissue paper  
gift wrap or construction paper

Ruler

Tape

1 pipe cleaner

#### DIRECTIONS

Place the tissue paper on the work surface so one of the long sides is closest to you. Make a fold on a long side 1/2 in. from the edge. Press hard to make the fold stay in place. Turn the paper over and make another fold about 1/2 in. from first fold. Turn and fold again and again until all the paper is folded. Wrap a piece of tape around the center of the folded paper. Unfold the ends to make the bow. Bend the pipe cleaner into the shape of the letter C. Tape the center of the pipe cleaner to the center of the bow. Wear bow around your neck as a clown's bow tie or in your hair as a headband.

#### MEGAPHONE

Materials:

Scissors

One 9X12 in. construction paper

Decorate with crayons, markers etc.

Tape or glue

Buttons

#### DIRECTIONS

Cut 9 in. square from the paper. Save both pieces. With a crayon, draw a line to round off one corner of the square. Cut off. Draw designs on the paper. Bring paper together and tape. If necessary, cut off the top of the cone to make an opening you can talk through. If you like, make a handle for your megaphone. Cut a 1 X 9 in. strip from remaining paper and make a ring. Flatten ring and glue to megaphone. Or use pipe cleaner for handle.



# IT'S A CIRCUS OF STARS

## October 2004

### Songs

#### CIRCUS SONG

(Tune: "I've Been Working on the Railroad")

I am walking through the circus,  
Happy as can be.  
I am walking through the circus,  
Just to see what I can see.  
I can see the clown laughing.  
I can see the elephant, too.  
I can see the lion sleeping.  
Look out! He sees you.

[www.angelfire.com](http://www.angelfire.com)

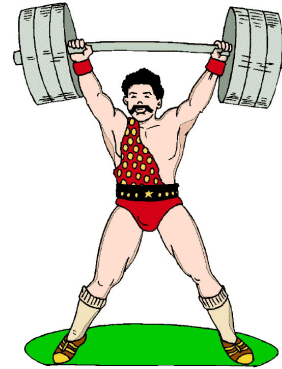
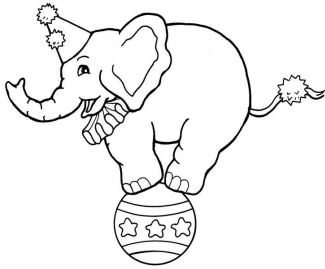

#### TAKE ME OUT TO THE CIRCUS

(Tune: Take Me Out to the Ballgame)

Take me out to the circus,  
Take me to the Big Top.  
I want to see the clowns tumbling,  
As I eat popcorn and drink soda pop.  
Oh, the lions and tigers may scare me,  
The high wire acts will amaze.  
So it's me, you.....oh, the things we will do  
On our circus days !!!!!!!

#### THE CLOWNS IN THE CIRCUS

(Tune: The Wheels On The Bus)

The clowns in the circus make us go ha ha ha  
ha ha ha , ha ha ha  
The clowns in the circus make us go ha ha ha  
All day long!

The lions in the circus go grrrr grrrr grrrrrr  
grrrr grrrr grrrrrr , grrrr grrrr grrrrrr  
The lions in the circus go grrrr grrrr grrrrrr  
All day long!

The elephants in the circus go errrrrrr eerrrrrrr eerrrrrrr  
errrrrrr eerrrrrrr eerrrrrrr , errrrrrr eerrrrrrr eerrrrrrr  
The elephants in the circus go errrrrrr eerrrrrrr eerrrrrrr  
All day long!

The hot dog man at the circus yells red hots here!  
red hots here! , red hots here!  
The hot dog man at the circus yells red hots here!  
All day long.  
(Continue by adding verses that the boys make up!)



# IT'S A CIRCUS OF STARS

## October 2004

### Skits

#### FLEA CIRCUS

*Characters: Ringmaster, 3 (or more) Cub Scouts*

Ringmaster: Ladies and Gentlemen, we are proud to introduce the Den \_\_ Flea Circus. Prepare to be amazed at the extraordinary skill of these miniature performers! First up, we have Hugo, who will walk the tight rope. When he reaches the middle, he will do a double somersault. Silence please!

[Two scouts hold a string taut while a 3rd places a "flea" on the string. They all pretend to be watching the flea's progress. The 3rd boy breathes in with deep amazement, then suddenly begins choking/gagging sounds

3rd Cub: "Uh Oh! I swallowed Hugo!"

Ringmaster: "Well, uhh... on with the show! Next we have Homer The Diving Flea! Homer will jump from this Scout's hand into the water and then back again!

[Scout holds his hand, palm up and carefully approaches a cup. They all pretend to see Homer jump into and then back out of the water.]

Ringmaster: "Oh! Wow! he did it! Let's give Homer a big round of applause!"

[The scout who had his hand out also claps -- then realizes what he's done...]

1st Scout: "Oh, No! Homer!"

[ Opens his palms to the audience as if he's squished Homer ]

Ringmaster: "Well, hmmm. Folks, the show must go on! and for our final act, we have Hector the Jockey Flea! Hector can ride around on a Cub Scout's back without falling off!

[1st Cub pretends to place a flea on 2nd cub's back. 2nd cub then runs around for a few seconds.]

Ringmaster: "See! He hung on! Way to go Hector!"

[One of the other Cubs pats the 2nd cub's back and says "Way to go, Buddy!" then realizes what he's done.]

3rd Scout: "Uh-Oh."

[All the scouts run off...]



# IT'S A CIRCUS OF STARS

## October 2004

### Games

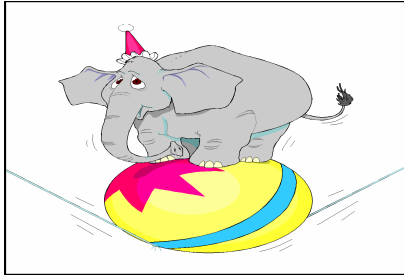

#### **ELEPHANT RELAY**

Have the boys place a clean sock over one hand. Scatter peanuts on the floor. On go the first boys must use his covered "elephant trunk" to pick up two peanuts and place them in the bucket. He then returns to the end of the line and the next boy goes. Continue until all boys have had a turn.

#### **HA, HA , HA**

Equipment: None

Formation: Circle

Arrange the players in a circle. Have the first say 'ha', the second in turn, 'ha, ha', the third, 'ha, ha, ha', and so on around the circle. The ha's must be said without laughing. Those laughing while uttering their ha, ha's are eliminated. The one staying in the longest wins.

#### **CENTER RING**

Sit everyone in a circle, and call it "center ring" Let each child have a turn doing a somersault, jumping jack, etc.

#### **CLOWN BEANBAG TOSS**

Draw a large clown face on a piece of butcher paper, cardboard, or fabric. Collect several beanbags. Tape the clown face to the floor a few feet away from the clown. Have your children stand behind the line and take turns trying to toss a beanbag onto the clown's nose.

#### **TIGHTROPE**

Materials: Masking Tape - Place a line of masking tape on the floor to represent a tightrope.

Ask the boys if they have ever seen a tightrope performer at the circus. Let them take turns sharing their experiences. Then have them line up at one end of the masking tape and take turns using different parts of their bodies to 'walk the tightrope'. Call out directions such as these. 'Walk the tightrope on your toes! Walk the tightrope using your elbows! Walk the tightrope on your knees! Walk the tightrope using your nose!' For a fun touch let the boy's try carrying a small umbrella.

<http://www.icomm.ca/daycare/cardsb02.html#CIB0183>

#### **FEED THE ELEPHANT**

Form Teams into dens. For each team, hang a megaphone so that it is slightly tilted with the mouthpiece down and the large end towards the peanut tosser. Have a basket or other receptacle to catch peanuts as they fall through the megaphone. Each tosser gets 10 peanuts and tries to toss them into the elephants open mouth (the large end of the megaphone) while standing 8 to 10 feet away. The team that scores the most wins.

# IT'S A CIRCUS OF STARS

## October 2004

### Advancement Ceremonies

#### CIRCUS

*Cubmaster: (Dressed as Ringmaster)*

Ladies and Gentlemen, you are about to see Circus like you have never seen before! For our first act tonight we have trained Bobcats and their trainers (parents). They will be in the center ring and will perform for us showing what feats they have mastered. (Bobcats and parents come forward and go through Bobcat requirements with Cubmaster. Badges are presented.) Notice how these Bobcats have been trained well by their trainers. Let's have a fine round of applause for this fine act we have just seen performed before our very eyes!

And now we have for our second colossal circus act of achievement this evening, a fine trained Wolf act. The Wolves in this act are: (read boys' names receiving Wolf badge or arrow points under Wolf badge.) Here come those Wolf Cubs and their trainers into our center ring! (Boys and parents come forward)

(Handle Bear badges and arrow points in same manner as Wolf.)

And now ladies and gentlemen, we have a stupendous act which takes much skill and requires work and patience as these young men climb to great heights . . . in fact, to the very top in the Cub Scout Circus of Achievements. Let's all watch breathlessly as we give special honors in a ceremony, which will demonstrate to you, what heights these boys have climbed with the help of their trainers along the way. It is a privilege to introduce you to the participants in this outstanding feat. (Call boys, Webelos Leader and parents forward.) (Present activity badges with appropriate language pertaining to badge, such as:)

These are our skilled athletes . . . who have shown their dexterity in physical fitness feats (or) These are the aquanauts whose remarkable agility in the water is unequalled... etc. And now for the stars of our show... the young men who have completed the requirements for the Arrow of Light... the highest award in Cub Scouting. In order to qualify for this award, these young men have shown superior knowledge about Scouting, citizenship and emergency first aid. As these stars step into our center ring let's give them a roaring round of applause. (Read names...)

We have presented for you one of the most exciting, most stupendous show in the history of Cub Scouting. The young men you have seen before you have attained the heights of achievement ... an amazing array of ability and stupendous skill. . . an extravaganza extraordinary!



# IT'S A CIRCUS OF STARS

## October 2004

### Run On/ Applause

#### APPLAUSES

**Bear:** Growl like a bear four times, turning halfway around each time.

**Elephant:** Let arm act as a trunk, wave it brokenly in front of your face. Raise your forearm up and down and say, "Peanuts, peanuts anyone?"

**Ferris Wheel:** Move right arm in a large circle, on the upswing say: "OHHHHH!" On the downswing say: "AHHHHH!" Variation: Insert the following between the ooh and aah above: when you are at the top, hold arm in place and rock back and forth and hold other hand over the eyes and say: "GEE, YOU CAN SURE SEE A LOT FROM UP HERE!!!"

**Tightrope Walker:** Have your arms out as if balancing on a tightrope. Lean to one side and say "Aaaiiiii" as you simulate falling.

**Strongman:** Attempt to lift bar-bell and say "AAAaagh!" as you get the weight up above the head, then drop it to the floor saying, "THUD!"

**Monkey Cheer:** Ooo, Ooo, Ooo (while acting like a monkey)

**Elephant Cheer:** Let your arms act as your truck, waving it in front of your face. Then raise your arms up and make trumpeting noises.

#### RUN ONS

Why aren't elephants allowed on the beach?  
Because they can't keep their trunks up.

Why do elephants have so many wrinkles?  
Have you ever tried to iron one?

What kind of animal eats with his tail?  
All kinds—they can't take them off.

Why did the snake shed its skin?  
To get to the other hide.



#### JOKES

What time is it when an elephant sits on your bed? Time to get a new bed!

What did the banana do when the monkey chased it? The banana split!

Why did the elephant leave the circus? He was tired of working for peanuts!

What animals do you have to be careful of when you take exams? Cheetahs!

What happened when the lion ate the comedian? He felt funny!

Why does a giraffe have such a long neck? Because his feet stink!

# IT'S A CIRCUS OF STARS

## October 2004

### Closing

#### MAGIC OF THE WORLDS - Cubmaster minute

As parents, we want to show our sons the wonders of the world. In the eyes of a child, there are not just eight wonders of the world but eight million. We want him to be able to look at the stars, sunrise, sunset, and feel their beauty. We want them to see a world of love, laughter, and compassion. We want them to build strength within themselves of strong character and a sensitivity to the needs of others. We want them to be the best they can be. Unfortunately, no one can wave a magic wand so that they will receive these things. We as leaders and parents must set the example to show the guidance so they may see the way to accomplish all of these things. This is the magic; Our example and guidance. So as we leave, let's be aware of our actions and how loudly they speak to our youth.

#### THANK YOU

*Let the Cub Scouts prepare eight large placards, each with a large letter painted on it to match the initial letter of each verse. As each verse is recited by a Cub, the proper letter is displayed so that at the end of the eight verses, the words "Thank You" are visible to all.*



**T**- stands for teacher, ours bear the test, as a Pack - we promise "We'll do our best".

**H** - is for helpful, which we try to be as each helps the other in the highest degree.

**A** - for advantages we all enjoy, we try to be grateful and wisely employ.

**N** - is for nation whose future depend, on all of us in the pack who want to be friends.

**K** - is for knowledge we're going to need. We'll work hard to gain it and hope we succeed.

**Y** - is for youth all over the land. God bless and keep us and steady our hand.

**O** - for opportunity around everyone. We'll grasp and hold tightly until we have won.

**U** - stand for usefulness, we like to serve. We do what we can all praise to deserve.

# IT'S A CIRCUS OF STARS

## October 2004

### After the Meeting

#### **CIRCUS CAROUSEL**

Take a two large sugar cookies. Cover one side of each with frosting. Insert thick pretzel sticks around the rim on each frosted side, Arrange two or three animal crackers between the pretzels to finish off your edible circus carousal.

#### **CLOWN FACE**

Place a pear half on a plate. Arrange shredded carrots around the small end for the hair. Use raisins to crate eyes and a mouth, and a cherry for the nose.

#### **BIG TOP TRAIL MIX**

Mix 4 cups popped popcorn  
1 cup peanuts  
1 cup animal crackers  
1 cup chocolate pieces  
Put in a ziploc bag and shake.

You can decorate bags with colorful stickers before filling.

#### **BIG TOP TRAIL MIX II**

Mix 4 cups popped popcorn  
1 cup peanuts  
1 cup round toasted oat cereal  
1 cup raisins.  
Put in a ziploc bag and shake.

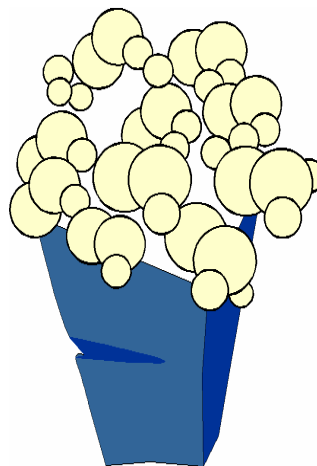

#### **HOMEMADE CRACKER JACKS**

What you'll need:

1 cup honey  
1/2 stick butter  
popcorn  
peanuts

What to do:

Pop your popcorn according to the directions.

Mix as many peanuts as you think you'd like to the popcorn and put this mixture to the side.

Heat your honey and butter in a saucepan until the mixture is well blended.

Pour the honey and butter mixture over the popcorn and peanut mixture and stir as you pour.

When the popcorn and peanuts are well coated, spread it all in a pan.

Bake in an oven that is 350 degrees for about 5-10 minutes and stir it frequently.

Cook until crisp. You don't want it to turn too brown so keep your eye on it.

[www.chevroncars.com](http://www.chevroncars.com)

# IT'S A CIRCUS OF STARS

## October 2004

### Showman

#### THEATER DEFINITIONS

Invite Student actors from the local High School or acting institutes in your area to come in and talk to the boys about acting as a career. Let them demonstrate the different definitions used in acting. See if they would be will to present a demonstration of the various styles of acting to the boys.



- Blocking --** This is how actors move on stage and where they move.
- Down stage --** The part of the stage closest to the audience.
- Upstage--** The part of the stage farthest from the audience. In old theaters, the stage used to slant down toward the audience so that the audience could see the actors better. This is called a raked stage.
- Stage left --** The part of the stage to the actor's left.
- Stage right --** The part of the stage to the actor's right.
- Center stage --** The center of the stage.
- Open Turn --** Actor is to turn toward the audience
- Closed turn --** Turn made away and with the actor's back to the audience, usually considered a poor movement. The opposite, an open turn, is most often preferred.
- Cross --** Movement of an actor from one position on the stage to another
- Cross above --** To move upstage/behind a person or prop
- Cross below --** To move downstage/in front of a person or prop
- Down Right --** Acting area closest to the audience and on the right side of the stage as you face the audience (the actor's right)
- Entrance --** 1) entering the stage; 2) opening in the set that is used for entering
- Exit --** 1) leaving the stage; 2) opening in the set that is used for leaving
- Move in --** To cross toward the center of the stage
- Move out --** To cross away from the center of the stage
- Turn In --** Actor is to face upstage, away from the audience
- Turn Out --** Actor is to face downstage, toward the audience
- Up-Left Center --** That part of the playing area farthest from the audience and just left of center as you face the audience (the actor's left)
- Upstaging --** To cross deliberately to a place upstage of another actor and assume a full front or one quarter position, thereby forcing the other performer to turn to a three-quarter position in order to talk with the up stager
- Front or Act Curtain (house curtain):** Curtain that masks the acting area or stage from the audience. Opens show and can be used to separate Acts.

# IT'S A CIRCUS OF STARS

## October 2004

### Showman

#### THEATER DEFINITIONS continued

- Apron:** Area between the front curtain & edge of the stage.
- Proscenium Opening:** Opening through which the audience views the play or performance.
- Theatre in the Round (arena stage):** A stage which may be viewed from all sides simultaneously.
- Wings:** Offstage areas to R and L of acting/onstage area.
- Teaser:** Heavy curtain hung from above the proscenium opening to adjust the height of the opening.
- Tormentors:** Curtain or flats on the sides of the proscenium opening used to vary the width of the opening.
- Borders:** Short curtains hung above the acting area to mask lighting and flown scenery from audience.
- Tabs:** Long curtains hung parallel to the tormentors on both wings to create masking or entrances.
- Trap:** An opening in the stage floor.
- Fly Loft (flies) --** space above the stage where scenery may be lifted out of sight of the audience
- Drop:** A large cloth (often painted) used for creating a scene or picture background on stage.
- Scrim:** A drop of loosely woven material (cheesecloth) that is opaque if front lit and is transparent if backlit.
- Flats:** Wooden frames with a flat surface used to create walls or separations on stage.
- Backstage --** stage area beyond the acting area, including the dressing rooms
- Offstage --** areas of the stage not in view of the audience
- Pit --** area immediately below the stage, usually lower than the auditorium level; used by the orchestra
- Platform stage --** stage raised above the audience area, which is placed at one end of a room
- Spike --** to mark the stage floor with chalk or tape to indicate the position of furniture, properties, or scenery so that they will be placed correctly during scene shifts.

# IT'S A CIRCUS OF STARS

## October 2004

### Showman

#### SUGGESTED ACTIVITIES

The showman activity badge has something for everyone. For the natural actor there's drama; for the shy boy, puppetry; for almost every boy, music.

Note that the Webelos Scout completes requirements in only one of these fields to earn the badge. Some boys may want to dabble in all of them.

For the boy who is too self-conscious to perform in public, there is still plenty of opportunity to earn the badge – perhaps by concentrating on puppetry or by doing the “behind the scenes” requirements for drama.

The goal of this activity is not to produce skilled entertainers, but to expose boys to theatre and musical arts, and of course to have fun. At a den meeting discuss the requirements. Find out which of the three areas – puppetry, music or drama – each boy wants to work on. It may be that one of the areas attracts no one. Plan the remaining den meetings accordingly.

The community may have some resources to enrich the program. Is there a professional or amateur community theatre group nearby? A choral society? Barbershop singing group? Puppet theatre? If so, consider arranging a visit to one of these instead of a regular den meeting. Invite a member of one of these groups to a den meeting to answer questions and demonstrate their specialty. If these resources are lacking, perhaps the den could visit a high school drama club or invite the school drama coach to a den meeting. You might see if one of the local schools “special” chorale groups could come a visit the boys.



Of all the activity areas, showman is the easiest to prepare for a pack meeting “demonstration.” Naturally it’s a show. At the Pack leaders monthly planning meeting, ask the Cubmaster whether extra time can be given to the den. If 10-minutes or more can be set aside, the den can develop a fast paced show, using some of the skills the Webelos Scouts learn from this badge. They could have a 3-minute puppet show; a 3-minute medley of popular songs; and a 3-1minute skit by the boys. The emcee for this show could be the Den Chief. Excellent sources of skits are the program helps, roundtable book, or Pow Wow book.



# IT'S A CIRCUS OF STARS

## October 2004

### Citizen

#### TEST YOUR KNOWLEDGE ABOUT THE FLAG AND THE PLEDGE OF ALLEGIANCE

Circle the best answer:

1. The word "pledge" means a  
promise      bird
2. When we pledge allegiance to the flag, we are promising to help to keep our  
country  
happy      free
3. Being loyal to our country means we are willing to help with our country's  
problems      presents
4. Allegiance means being  
kind      loyal
5. This person helped design and sew the first American flag  
Betsy Ross      Abigail Adams
6. The American flag has how many stripes  
20      13
7. The first American flag had the stars in a  
triangle      circle
8. The American flag has one star for every  
state      country
9. The pole on which the flag is hung is called  
the  
staff      state
10. The blue part of the American flag is called  
the  
field      staff
11. The American flag should be held at what  
level with the state flag  
higher      lower
12. The flag should be raised with respect. What speed should the flag be raised  
Fast      slowly
13. If the flag gets dirty it must be  
burned      laundered
14. The American flag should be folded  
In a triangle      like a tablecloth
15. To respect the flag one should salute and  
stand      sit down



# IT'S A CIRCUS OF STARS

## October 2004

Citizen

IDENTIFY THE PARTS OF A FLAG

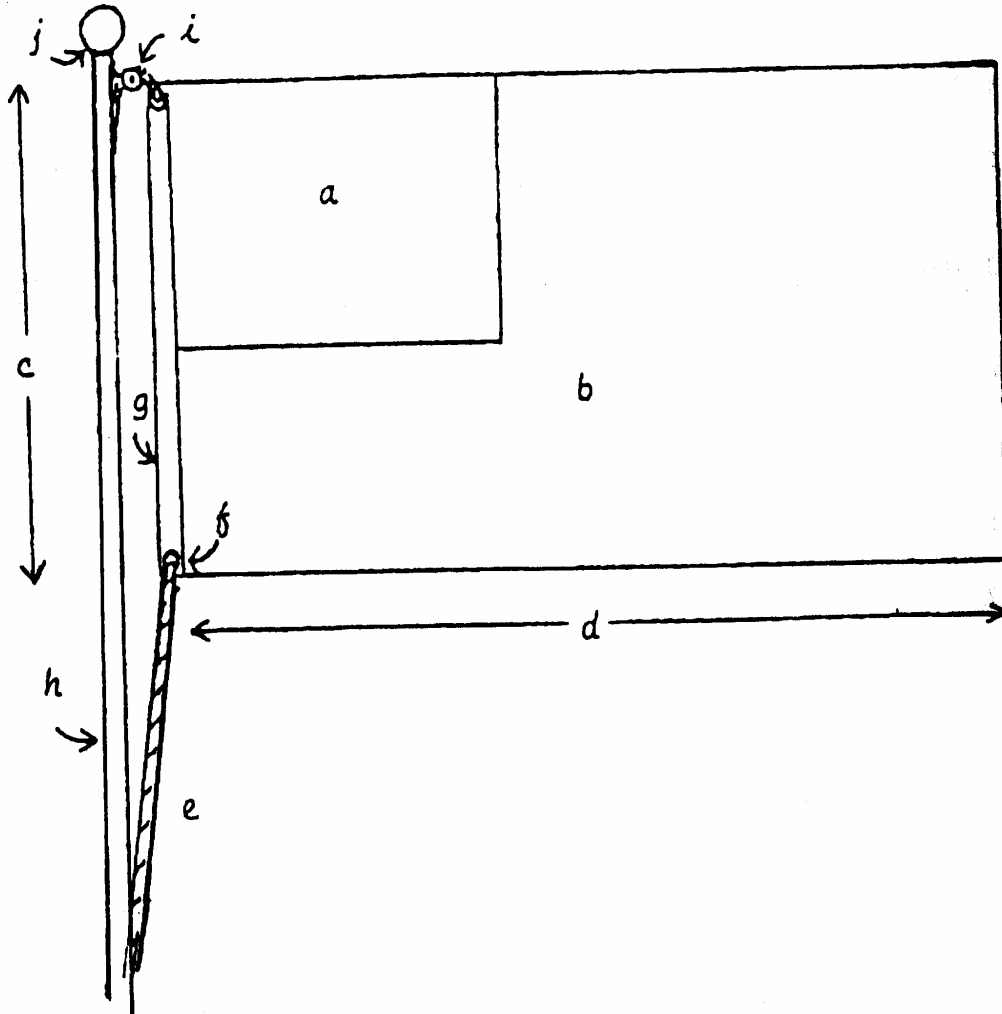

Field \_\_\_\_\_  
 Grommet \_\_\_\_\_  
 Halyard \_\_\_\_\_  
 Truck \_\_\_\_\_  
 Fly \_\_\_\_\_

Canton \_\_\_\_\_  
 Heading \_\_\_\_\_  
 Hoist \_\_\_\_\_  
 Staff \_\_\_\_\_  
 Finial \_\_\_\_\_

(Field-b, Halyard-e, Fly-d, Heading-g, Staff-h, Grommet-f, Truck-i, Canton-a, Hoist-c, Finial-j)

# IT'S A CIRCUS OF STARS

## October 2004

### Citizen

#### HOW TO MAKE A PORTABLE FLAG CEREMONY KIT

*Materials needed:* 40' of nylon or cotton rope  
2 swivel snaps (or safety pins)  
1 - 3' x 5' flag  
1 small stuff sack to carry and store kit in  
**OPTIONAL**  
3 red sashes that are 3 1/2 " wide and 6' long for "color Guards"  
to wear

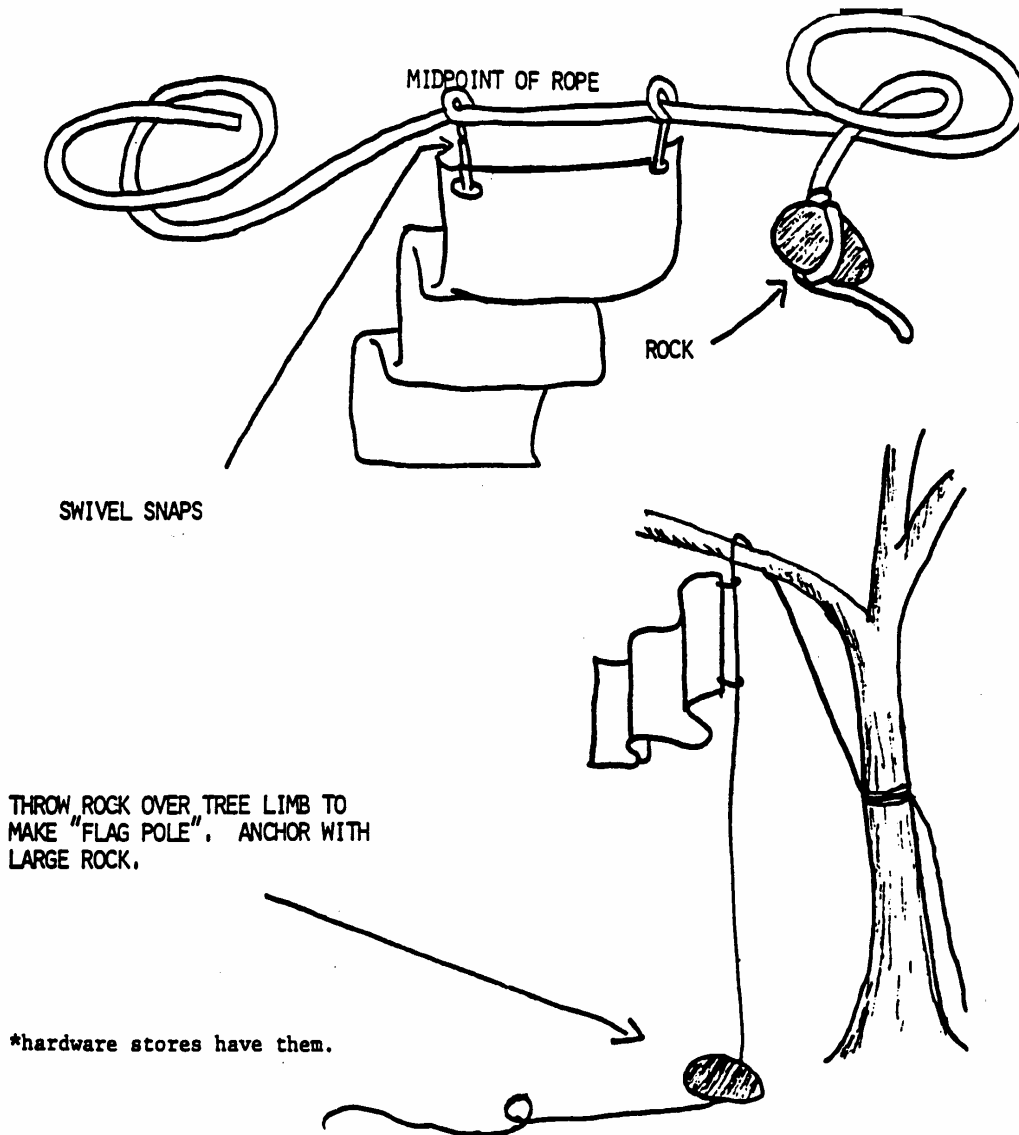

# IT'S A CIRCUS OF STARS

## October 2004

Citizen

### I HAVE MY RIGHTS!

Think about the rights you have or would like— and the ones you owe to other people. Then, on another sheet of paper, answer the questions below.

#### At home

What rights do you have in your family? What rights do you want your parents and other family members to respect? What rights do *you* respect?



#### At school

What rights do you have at school? What rights do you expect from your teachers and fellow students? What rights do *you* give?



#### With your friends

What rights do you have that you want your friends to honor? What rights do *you* honor?



#### On your job

If you have a paper route or do odd jobs, what rights do you have on your job? What rights do you want your employer to honor? What rights do *you* give your employer?



#### CHALLENGE

Have you ever been in a situation in which someone didn't respect your rights or someone else's rights? What happened? How did you feel?

# IT'S A CIRCUS OF STARS

## October 2004

### Citizen

#### CITIZENSHIP CIRCLES

Turn your Webelos into active young citizens with this project. Cover part of a wall with white paper and make the following diagram on it:

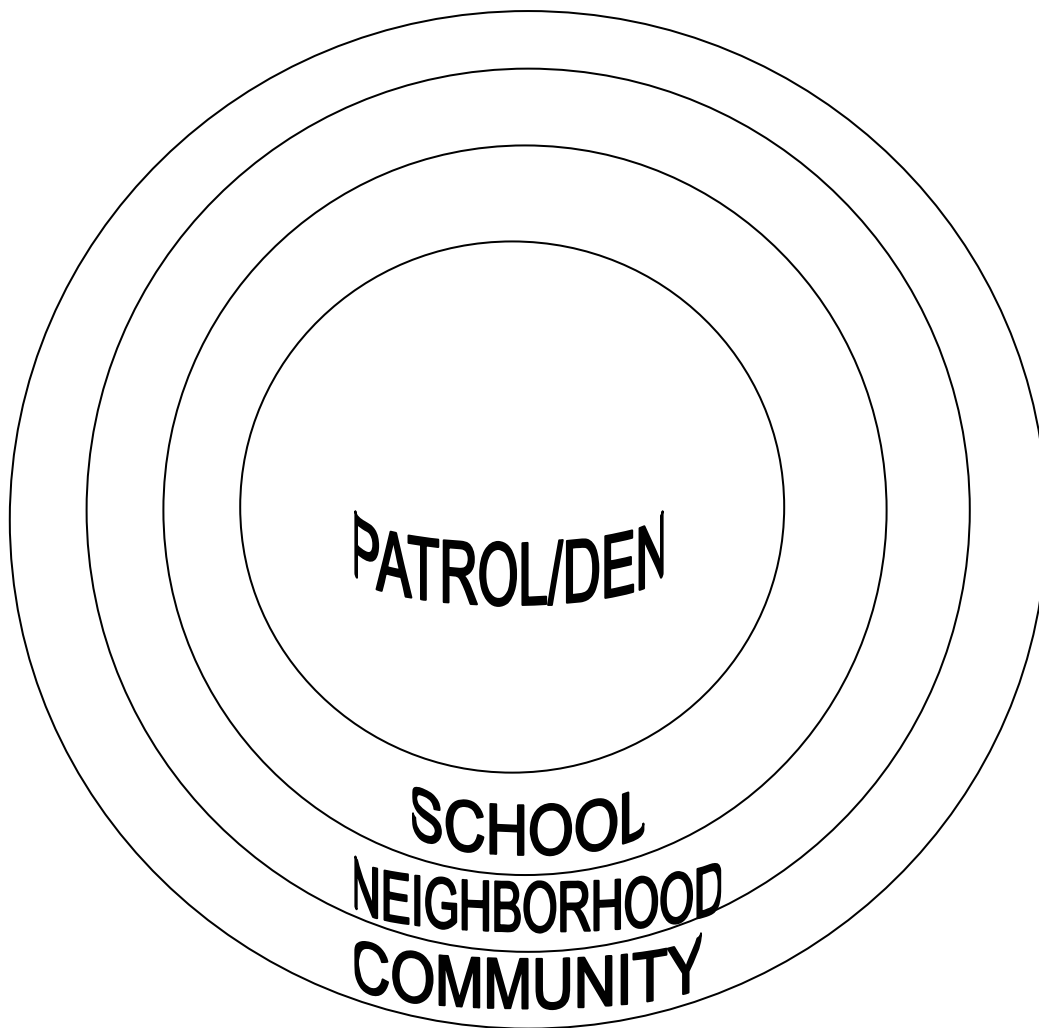

Have the boys list ways they can make their den a better place. Then challenge each boy to perform one act of good citizenship within the den that week and record it on the circle. The following week, concentrate on ways they can improve the school, After discussing possibilities, have the boys carry out a proposal and write it on the circle. Next, expand to the neighborhood. Then ask the boys to look in the local newspapers for articles about people who displayed good citizenship in the community. Tape the articles around the circle. Invite volunteers to speak to the class about the different ways they give their time and resources to help others in the community. Ask your boys to think of ways they could volunteer their services in the community. Encourage family involvement. Finally, complete the circle by having the boys write in the ways they expanded their citizenship responsibilities to their community. Display at pack meeting.

# IT'S A CIRCUS OF STARS

## October 2004

### Tigers - Magic Fun Family Activities

**Learn to do the tricks yourself and teach one or two of them to the children. One or both parents, or an older sibling can learn and then choose a night to have a family magic show.**

#### "DICEY"

This mysterious bit of mental magic can be performed just about anywhere due to the fact that it utilizes items that can be found in almost any household.

The magician passes the dice to an audience member, saying, "Take the dice and roll them onto the table." The audience member does so and the dice roll to a stop. We will assume that the uppermost numbers are a six and a five. The magician asks the audience member to add the two numbers together. This results in a total of eleven.

The magician points out that if the two top numbers were arrived at by random, then certainly the two, unseen, bottom numbers were also. The magician has the audience member turn over the dice and total the two bottom numbers. The bottom numbers, a one and a two, total three. The magician asks the audience member to add the bottom total to the top total. This results in the number fourteen.

The magician removes the deck from its case and hands it to the audience member, saying, "You rolled the dice and arrived at a random number, the number fourteen. Please take the deck and count down to the fourteenth card." The fourteenth card is turned face-up and revealed to be the king of hearts. The magician has the envelope opened and the prediction read aloud. It reads: "I predict that you will select the king of hearts."

**SECRET:** Prior to the performance write "I predict that you will select the king of hearts" on a piece of paper. Place the paper in an envelope, seal it, and write the word PREDICTION on its face. Remove the deck of cards from the case, locate the king of hearts and place it in the fourteenth position. Place the deck back in the case and you are ready to perform.

If you perform the trick exactly as it's described, the audience member will always select the fourteenth card. The reason for this is really quite simple. The top and bottom numbers of any single die always total seven. This is a fact that most people are not aware of. Therefore, when the numbers on the top and bottom of a pair of dice are totaled the number will always be fourteen. Needless to say, since the total is always fourteen, it is important that you do not repeat this trick before the same group of people.

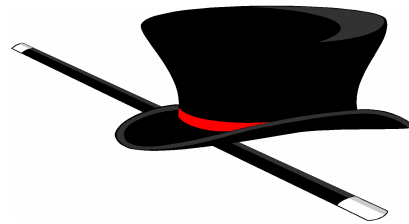

# **IT'S A CIRCUS OF STARS**

## **October 2004**

### **Tigers - Magic Fun Den Activities**

#### **MAGIC HATS**

Have the boys decorate their very own magic hat. You can buy pre-made black top hats and have them decorate them with glitter, ribbon, pom-poms, and other fun materials that you find at a local craft store.

#### **MAGIC COSTUMES**

Have the boys and their partner's dress up as magicians, or as Harry Potter. Then perform one of the tricks they learned as a family. Give a prize for best effort, best performance, best costume, and originality.

#### **KNOT TRICK RELAY**

What you'll need:

A 3-foot long rope or piece of string

Tie a knot in a piece of rope without letting go of the ends. Once the boy's and their partners have learned the trick. Divide into two teams and have a relay to see who can complete the trick the quickest or give each a piece of rope and see which boy/partner team can finish the quickest.

1. Lay the string down on a table.
2. Cross your arms and grab an end of the string in each hand.
3. When you uncross your arms, a knot will appear in the middle of the string!

#### **WANDS**

All you need is a dowel, some paints, and other craft materials if you so desire. Have an adult cut the dowels to appropriate size. Let the boys paint the dowel black with a white tip on the end. They can add gold streamers or use star stickers and let them decorate their wands after they have dried.

#### **WORD MAGIC**

Try to see how many small words the boys can make using the word "MAGICIAN",

### **Go See It**

- Take the boys to a magic shop
- Visit a magician or have them come see the boys
- Go see a magic show

# IT'S A CIRCUS OF STARS

## October 2004

### Cubmaster Corner - Ceremonies and Training

#### CEREMONIES ARE IMPORTANT

Ceremonies are important for many reasons, the most important being that boys like them. The boys like to participate in them to receive recognition. Ceremonies are also important for recognition of leaders, for achievements, for special occasions and holidays. Ceremonies help to teach the ideals and goals of Scouting and citizenship. They can help to promote participation of family, which is very important as Cub Scouting and the Tiger Cub program are family-oriented programs. Ceremonies also help maintain order in meetings when properly used. It is important to remember to keep ceremonies simple so there won't be too much for the boys to memorize, yet use as many boys as possible.

Do you remember the best ceremony you ever saw? The worst? Was it the first or the last ceremony you remember? Were you on the receiving or giving end of the ceremony? If you could answer any of these questions you already know the importance of ceremonies. Most people take ceremonies in our lives for granted, especially if they are a spectator and not a participant. In Scouting we cannot take ceremonies for granted. Ceremonies take planning and effort to perform a good one. If they are done badly or not at all an important part of the program is lost.

Imagine how you would feel if you worked hard and long to earn a badge, and it was just given to you with nothing, really nothing else. Now imagine if that happened to a young Tiger Cub who finally after a great struggle earned his Tiger paw, his very first earning of anything. Put your imagination to work again and think how it would look if this Tiger Cub and his parents were called up in front of the entire pack and all the other parents. Imagine the Cubmaster dressed as a King knighting the boy and presenting him with the first of many symbols to be placed upon his shirt of armor! The Committee Chairman reads aloud the many challenges the boy overcame and calls him "sir Knight." His parents receive the paw on a ribbon from a satin pillow to pin on his chest. The entire audience stands and gives him a standing ovation. Can you see that smile on that boy's face, the feeling of pride in his chest? Can you now see the importance of recognizing each and every Tiger, Cub and Webelos Scout for his accomplishments with an appropriate ceremony?

Scouts will remember their awards and how they were recognized for earning them. The presentation ceremonies are important to all, especially to the boys. It is their time to shine in their glory. The badge is important to the boy because it is a symbol to show others what he has done. But a little creative imagination going into how he receives his badge will have a long lasting effect. Not only will that boy remember but every boy in the audience will also. There will be excitement and inspiration for all to work for their next badge because who knows what might happen then?

The most important occasion in the life of a Tiger Cub is his graduation into Cub Scouts. This event, above all, should have a lasting impression on all concerned, especially the graduating Tiger Cub. This should be very special, the best you can do. Don't underestimate the importance of ceremonies, especially this one.



# IT'S A CIRCUS OF STARS

## October 2004

### Cubmaster Corner - Ceremonies and Training

#### TRAINING IS FOR EVERYONE

Every Cub Scout deserves a qualified, trained leader who will provide them with the best program possible, in the way it is intended. A trained leader ensures that the goals of Cub Scouting are met. Every leader should be trained. Training helps leaders understand the aims and purposes of the Scouting program, improves ability to work with other leaders and boys, teaches Cub Scout skills and shows how to plan an effective Cub Scout program for the boys.

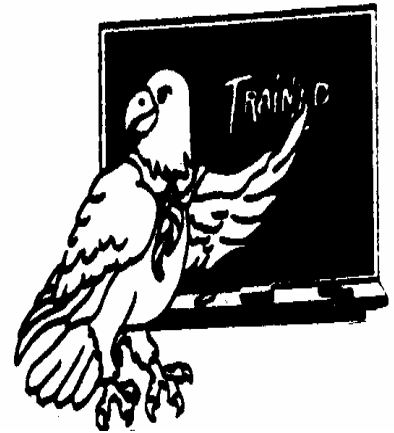

Training helps leaders acquire knowledge, develop good attitudes and learn skills, which are necessary to make the contribution to boys worthwhile. It shows how to use the many resources available to provide the best possible program for the boys, and it gives confidence to carry out the program.

The most successful leaders not only attend Cub basic Training but also take advantage of continuing training opportunities.

#### TYPES OF ADDITIONAL TRAINING

##### ORIENTATION

A short training session, which may be conducted at School Night for Scouting rallies or parent meetings. It introduces parents and new leaders to the total BSA program, with emphasis on Cub Scouting. It is a foundation for further training.

##### FAST START

Pamphlets and video used by trainers and experienced leaders to use in coaching new leader. This is a temporary help until new leaders can receive Cub Scout Leader Basic Training. The Fast Start tape should be viewed before attending Basic training.

##### BASIC TRAINING

This is a job-oriented training. Each Leader attends training sessions, which relate to his/her job. Group training dates are listed in *Council newspaper* and announced at monthly Roundtable.



##### ROUNDTABLE

A monthly District meeting held each month to provide leaders with program ideas on the monthly themes and activity badges, which can be used in den and pack meetings. It is also an informal sharing of ideas and

experiences, as well as a training session on how to put on a pack meeting. Each rank has their own session that they breakout into after the general meeting ends they are:

- Tigers
- Cub Scout
- Webelos
- Pack Administration- Cubmasters

# IT'S A CIRCUS OF STARS

## October 2004

### Cubmaster Corner - Ceremonies and Training

#### **POW WOW**

An annual ALL DAY, council wide training event for Cub Scout leaders, offering training in everything from Crafts to Outdoor cooking to Administration. All leaders are encouraged to attend this exciting, fun filled, informative event.

#### **PHILMONT CONFERENCES**

Week long training courses under the direction of the National Volunteer Training Committee. These courses are held during the summer at Philmont Scout Ranch, Cimarron New Mexico. Special programs for family members make it a great family vacation with the added attraction of training. It is an opportunity to get acquainted with and share experiences with Cub Scouters from all around the nation.

**A TRAINED LEADER EMBLEM IS AVAILABLE FOR ALL LEADERS WHO HAVE COMPLETED BASIC TRAINING APPROPRIATE TO THEIR POSITION.**



"NOW I GOTCHA!! YOU'RE GONNA GET TRAINED!!"

# NOVEMBER 2004 CUB SCOUT COLLECTORS



Boys like to collect things like bugs, baseball cards, rocks, sticks and candy wrappers. This is a great theme for working on the collections from the boys' handbooks. Take hikes or trips to start collections and explore. Make scrapbooks or boxes to display collections. Have a pack show and tell night similar to a science fair, where the parents and leaders view the collections as the Cub Scouts talk about them. Award prizes for several categories, making sure that everyone is recognized.

Cub Scout Theme ..... 03

Webelos – Craftsman ..... 22

Webelos - Scientist ..... 25

Tigers - Making My Family Special ..... 29

Cubmaster Corner - Scouting Good Turn  
(Scouting for Food) ..... 31

# NOVEMBER 2004 CUB SCOUT COLLECTORS

## Lincoln's Thanksgiving Proclamation

It is the duty of nations, as well as of men, to own their dependence upon the over-ruling power of God; to confess their sins and transgressions in humble sorrow, yet with assured hope that genuine repentance will lead to mercy and pardon; and to recognize the sublime truth, announced in the Holy Scriptures and proven by all history, that those nations are blessed whose God is the Lord. We know that by His divine law, nations, like individuals, are subjected to punishments and chastisements in this world.

May we not justly fear that the awful calamity of civil war which now desolates the land. May be a punishment inflicted upon us for our presumptuous sins, to the needful end of our national reformation as a whole people.

We have been the recipients of the choicest bounties of heaven; we have been preserved these many years in peace and prosperity; we have grown in numbers, wealth and power as no other nation has ever grown. But, we have forgotten God. We have forgotten the gracious hand which preserved us in peace and multiplied and enriched and strengthened us, and we have vainly imagined, in the deceitfulness of our hearts, that all these blessings were produced by some superior wisdom and virtue of our own.

Intoxicated with unbroken success, we have become too self-sufficient to feel the necessity of redeeming and preserving grace, too proud to pray to the God that made us. It has seemed to me fit and proper that God should be solemnly, reverently and gratefully acknowledged, as with one heart and one voice, by the whole American people.

I do, therefore, invite my fellow citizens in every part of the United States, and also those who are at sea and those who are sojourning in foreign lands, to set apart and observe the last Thursday of November as a day of Thanksgiving and praise to our beneficent Father who dwelleth in the heavens.

Abraham Lincoln  
(October 3, 1863)

*From Circle Ten Council*



# NOVEMBER 2004

## CUB SCOUT COLLECTORS

### Gathering Activity

#### A Yummy Puzzler

Have a collection of candy wrappers (or the real thing) and have people figure out what wrapper goes with which answer.

1. Greasy digits \_\_\_\_\_
2. A baseball player \_\_\_\_\_
3. A sarcastic laugh \_\_\_\_\_
4. One of Charlie Brown's girlfriends \_\_\_\_\_
5. A long run \_\_\_\_\_
6. A planet \_\_\_\_\_
7. Overweight \_\_\_\_\_
8. An author \_\_\_\_\_
9. A big mass of stars \_\_\_\_\_
10. What a worker looks forward to \_\_\_\_\_
11. Small Hills \_\_\_\_\_
12. The number before one \_\_\_\_\_
13. A famous trio of men \_\_\_\_\_
14. Definition of an object you can't identify \_\_\_\_\_
15. Mountain tops \_\_\_\_\_
16. The terminology of a body builder \_\_\_\_\_
17. The elite street in New York \_\_\_\_\_
18. A large sum of money \_\_\_\_\_
19. Pooh's favorite \_\_\_\_\_
20. A little laugh \_\_\_\_\_
21. A lazy cow \_\_\_\_\_
22. Feline nickname \_\_\_\_\_
23. Opposite of bad and few \_\_\_\_\_
24. Tumbling girl \_\_\_\_\_
25. Lazy Cowboy \_\_\_\_\_
26. African monkey parts \_\_\_\_\_

# NOVEMBER 2004

## CUB SCOUT COLLECTORS

### A Yummy Puzzler Answers

1. Butterfinger 2. Baby Ruth 3. Snicker 4. Peppermint Patty 5. Marathon 6. Mars 7. Chunky 8. O'Henry 9. Milky Way 10. Pay Day 11. Mounds 12. Zero 13. Three Musketeers 14. Whatchamacallit 15. Snow Cap 16. Crunch 17. Fifth Avenue 18. 100 Grand 19. Bit-O-Honey 20. Chuckle 21. Milk Dud 22. Kit Kat 23. Good 'n Plenty 24. Tootsie Roll 25. Slowpoke 26. Reese's Pieces

### Spell Pocket

Denver Area Council

Where else would a Cub begin his collection but in his pocket!!! On a sheet of paper, spell out the word 'pocket'. Using these letters, have everyone list items that you find in a boy's pocket.

For Example:

**P:** paper, ping pong balls, pencils, etc.

**O:** old candy papers, odd buttons, etc.

**C:** candy, cards, etc.

**K:** keys, kite string, etc.

**E:** envelopes, egg, etc.

**T:** trucks, tinker toys, etc.

### WHO COLLECTS WHAT

- |                       |                   |
|-----------------------|-------------------|
| 1. ROCK HOUND         | A. STAMPS         |
| 2. FOLD SINGER        | B. RECIPES        |
| 3. NUMISMATIST        | C. TIMETABLES     |
| 4. HAM RADIO OPERATOR | D. COINS          |
| 5. COOK               | E.. OLD FURNITURE |
| 6. LEXICOGRAPHER      | F. CALL NUMBERS   |
| 7. PHILATELIST        | G. FIRST EDITIONS |
| 8. ANTIQUE COLLECTOR  | H. BALLADS        |
| 9. RAILROAD BUFF      | 1. OBSIDIAN       |
| 10. BOOK LOVER        | J. WORDS          |

*(Answers: 1-I, 2-H, 3-D, 4-F, 5-B, 6-I, 7-A, 8-E, 9-C 10-G)*

### Clothespin Mixer

Northwest Suburban Council

**Equipment:** Clip-on clothespins - 3 or 4 for each person

The object here is to not get a collection. Give everyone 3 or 4 clothespins. Tell them that the object of the game is to get rid of their clothespins without having anyone else pin THEIR clothespins on them.

With everybody trying to get rid of his or her clothespins at the same time, as fast as possible, this is a rowdy and fun way to start a meeting.

# NOVEMBER 2004

## CUB SCOUT COLLECTORS

### Opening

#### What Do Boys Collect? Trapper Trails

**Preparation:** You will need each boy to have one of the following in his pockets: a frog (plastic, unless you are brave), dirt, marbles, rocks, and a small flag. Have boys practice their parts ahead of time.

**Cubmaster:** Have you ever wondered what boys collect and why? Let's see what we can find out tonight.

**Cub # 1.** **(pulls out frog):** This frog reminds me of freedom of speech, he can croak all he wants and no one stops him.

**Cub # 2.** **(pulls out dirt):** This dirt reminds me of our forefathers as they put their feet on American sod for the first time.

**Cub # 3.** **(pulls out marbles):** These marbles remind me of the pilgrims as they worked and played in this new land of freedom.

**Cub # 4.** **(pulls out small flag):** This flag stands for our country will you please join me in the Pledge of Allegiance?

#### Collections Heart of America Council

**Personnel:** 11 Cubs and Den Leader or Den Chief.

**Equipment:** Cards with letters spelling out **COLLECTIONS** with the text written on the back in **LARGE** print

**Narrator:** We would like to tell you what we collect from Scouting.

**Cub # 1.** **C:** is for Courtesy. A Scout learns to do good deeds and respect others.

**Cub # 2.** **O:** is for Outing. Outing is one of the most fun parts of Scouting. Camping and hiking, we always look forward to our time outdoors.

**Cub # 3.** **L:** is for Learning. A Scout learns many things, first aid, knots, physical skills, citizenship and sportsmanship.

**Cub # 4.** **L:** is for Leaders. One of the most important parts of the Scouting organization.

**Cub # 5.** **E:** is for Exploring. A Scout learns the skills he needs to explore the outdoors.

**Cub # 6.** **C:** is for Challenges. A Scout is presented with many challenges and is helped to meet them and to succeed.

**Cub # 7.** **T:** is for Try. A Scout learns to always try to do his best.

**Cub # 8.** **I:** is for Identify. A Scout learns to identify different kinds of leaves, trees and tracks.

**Cub # 9.** **O:** is for Observe. A Scout observes the Outdoor Code whenever he goes camping or hiking.

**Cub # 10.** **N:** is for Nationalism. Every Scout around the world is a patriot to his country.

**Cub # 11.** **S:** is for Scouting. We are very glad Baden-Powell had the vision to bring this program into being.

**Narrator:** *(Narrator or another Cub or Den Leader now leads Cub scout Promise, law of the Pack and / or Pledge of Allegiance)*

# NOVEMBER 2004

## CUB SCOUT COLLECTORS

### Opening

#### I Made A Promise

Denver Area Council

- Cub # 1.** I made a promise. I said that whatever I did, I would do the best I could.  
**Cub # 2.** I made a promise to serve my God and my country the best I could.  
**Cub # 3.** I made a promise to help other people the best I could.  
**Cub # 4.** I made a promise to obey the Law of the Pack the best I could.  
**Cub # 5.** I have done my best. I will do my best, because I am the best, I am a Cub Scout.  
**Den Leader:** Will everyone now join us in repeating the Cub Scout Promise.

### Den Activity

#### Collections

York Adams Council

There are so many positive things to be said for boys having collections. It teaches them to pay attention to something, to study something on their own initiative, to respect something (as in someone's property), and so much more. And top it all off with *IT'S JUST PLAIN FUN!*

So why not have the boys begin developing some collections of their own? Hey, how about stamps? Ever consider taking a field trip to your local Post Office and see what they have to offer? How about everyday collectibles, like rocks, leaves, insects, etc? You can get someone who collects things to come in and talk to the boys about what to collect and how.

#### Collecting

Denver Area Council And Sam Houston Area Councils

All kinds of collections can be found in boys pockets! Collecting is a very big part of every boy's life;

- Sport Cards
- Rocks
- Star Wars items
- Patches
- Stamps
- Coins
- Arrowheads
- Autographs
- TV or Movie posters

The list could go on and on. The Cub Scout program encourages collecting. You could take your den on field trips to special places too obtain information about collecting.

- Rock quarry: Rocks, gems, and minerals
- Butterfly Pavilion: Insects, butterflies
- Sports groups: Sports cards
- Scout Service Center: Patches
- Post Office: Stamps
- Federal Mint: Coins

Other ideas for collecting: Take a hike with a purpose. If you can't collect the actual items,, then bring along a camera to take pictures of the items. The pictures could be labeled and put inside an album.

- Check your Boy's Life Magazine - There are lots of suggestions for collections.
- Internet - surf he net for suggestions on collections.
- Collector's exhibits - family members - check out your attic or basement.
- Have fun with collections - you never know when it might turn into a lifelong hobby or occupation.



# NOVEMBER 2004

## CUB SCOUT COLLECTORS

### Den Activity

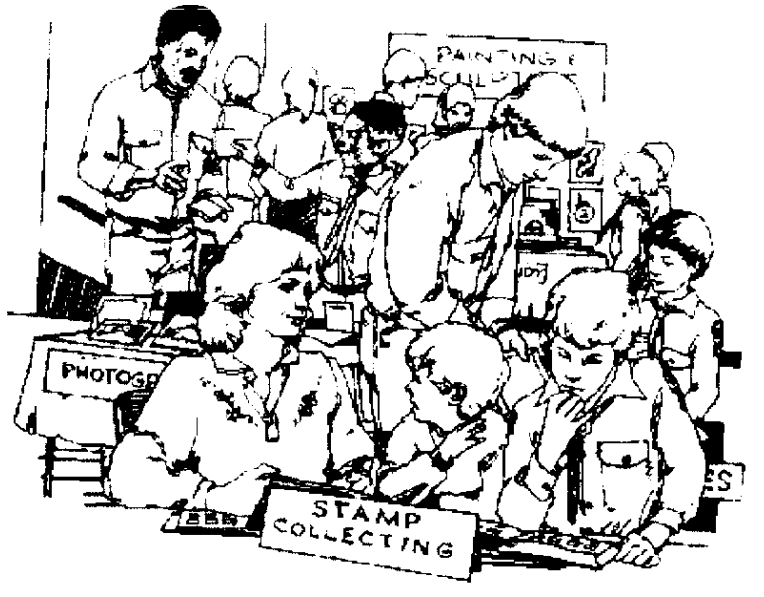

#### **Show-n-Tell**

York Adams Council

Yeah, I know. It sounds like something for a group of kindergartners. But really, this works too. We've talked before about how difficult it is for people to speak in front of others so you know this helps them warm to the idea. And, believe it or not, this is also a fun thing to do. (I know, because I sat through just the same thing when my son was in Cub Scouts. The boys really enjoyed doing it and the parents and families that "came out to the program" thought it was really neat too. And as I recall, the parents had to bring in and talk about their collections, too.

#### **PACK FAMILY HOBBY DISPLAY**

Have a family hobby corner at the pack meeting. Ask each family to bring a sample of what they collect as a family or things that represent their hobby. Families who like baseball can bring baseball equipment, uniform, baseball cards, photos and maybe some trophies. Families who like movies can bring movie posters and movie paraphernalia including popcorn! Families who collect seashells can bring some in a box. It doesn't have to be a "formal" hobby - it's something a family does together. How about a family who buys T-shirts where they go? Set a time during the meeting for families too go around and admire each other's hobby. Family members can take turns staying at the "booth" to explain about the hobby

# NOVEMBER 2004

## CUB SCOUT COLLECTORS

### Crafts

#### Rock Paperweights

Denver Area Council

Rocks are fun to collect, and these delightful creations are fun to give. Look for the best rocks that you can find, smooth, interestingly textured, shaped or colored, and get some glue paint, twine, eyes and other decorative materials.

Clean the rocks well. Choose a large rock for the basic body. Then either paint a face, picture or design on this rock and varnish, or choose smaller rocks to glue on as legs, head, eyes and ears. Paint and varnish. Pieces of yarn or string can be glued on for hair or tails.

#### COLLECTING POSTMARKS

This will get the boys started with the Wolf achievement or Bear arrow on collections. Ask each boy too bring a self-addressed, stamped Christmas card to the meeting. Put all their cards into a large envelope, and write "Postmark Request" in the lower corner.

Mail the envelope to Postmaster, C/O the town listed below. Your letters will then be mailed from that town and the boys will have "Christmas" postmarks for their collection.

Bethlehem, GA 30620  
Noel, MO 64854  
Silver Bell, AZ 85270  
Nazareth,, PA 18064  
Santa Claus, IN 47579

Mistletoe, KY 41351  
Rudolph, WI 54475  
Christmas, FL 32709  
North Pole, AK 99706  
Wiseman, AR 72587

Display stamps in a book or case so that you and others can enjoy the stamps with damaging them.

#### COLLECTING COINS

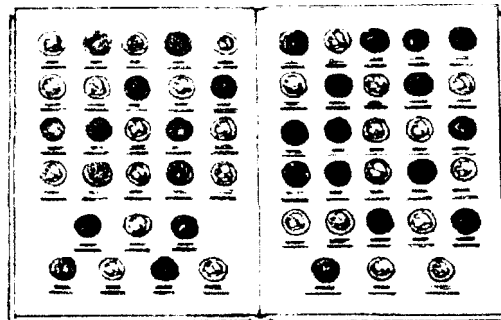

There are many places too find coins to start or add to your collection. Coin shops are obvious places too begin the search. Then there are coin shows, which offer plenty of choices, and often some very good bargains. No matter where you are in your collection, joining a coin collecting society can be a benefit. You'll met fellow collectors,, trade with them, learn the ins and outs of the marketplace, and be less likely to take any wooden nickels And you might make a friends, too. Coin folders are a great way to organize, catalog and display your coin collection.

# NOVEMBER 2004

## CUB SCOUT COLLECTORS

### Crafts

#### ALONG THE SHORE

There are so many pretty things to be seen along the shore - so many things that can add to a boy's knowledge - pretty stones and shells, beautiful flowers and funny bugs, turtles and frogs,, snakes and cattails, seed pods and birds.

The study and collection of shells is called conchology. Tiny shells can be kept in small bottles with screw caps or corks. Medium shells may fit into matchboxes. Larger shells can be kept in cardboard boxes. Shells can be mounted on cardboard with household cement. Each shell should be identified and labeled.

For a special display,, glue shells too golf tees with household cement. Then press the points of the tees into a piece of Styrofoam.

#### LEAVES AND SEEDS

Collecting the leaves and seeds from trees helps the cub Scout too learn to recognize many different trees. Seeds can be stored in glass pill bottles, plastic coin tubes, square and rectangular plastic boxes. For larger seeds such as walnuts, acorns, pecans,, Brazil nuts,, and peanuts, use plastic or cardboard egg cartons.

The best way to catalog seeds is too label each jar or box with the name. Self-sticking labels work well. Cardboard tags with strings can be used for labeling pine cones or similar large items.

To display the collection, the seed bottles or vials can be wired to heavy cardboard or a piece of plywood.

#### ROCKS AND MINERALS

A good place to find rock specimens is in roadbeds,, riverbeds, roads under construction, and building excavations. Choose rock and mineral specimens carefully. Don't pick up just anything. Wrap each in a piece of newspaper with a card to show where you found it.

Rocks can be chiseled to standard size (such as 2 by 3 inches) with a geologist's hammer or a regular hammer and a cold chisel. (Be sure to wear protective glasses when chiseling).

Label rocks by attaching a small label too the underside with transparent tape or by painting a small white spot, on which you can write the identification. Show the types of rock, where it was found, and the date. Small rocks can be kept in pill bottles. Larger rocks may be kept in sectioned boxes or egg cartons.

# NOVEMBER 2004

## CUB SCOUT COLLECTORS

### Songs

#### **PICK IT UP**

*(Tune: Caisson Song)*

Over hill, over dale,  
We will fill our pockets full,  
With whatever we pick off the ground.

Dirt and mud, bugs and snails,  
You will never see us frown.,  
As we pick it up off of the ground.

And it's hi, hi, ho.  
What fun it is for me.  
Gathering up string and tree moss.  
Where 'ere we go, you will always know,  
That we pick it up off of the ground.

#### **WHAT IS IT?**

*(Tune: Auld Lang Syne)*

I found it in an old tree stump,  
I found it in a tree.  
I put it in my right pocket,  
So no one else could see.

I left it there all through the night  
It stayed there through the night.  
I took it out the next day,  
And showed it to my mom.

She couldn't understand just why  
I had it in my pants.  
I told her that I had it there,  
So no one else could see.

She made me put it back outside.  
It didn't belong inside.  
It lives inside the old tree stump  
With other snakes alike.

#### **LOOK INSIDE**

*(Tune: Battle Hymn of the Republic)*

When I was eight years old, I found a big fat frog.  
Later on I found a garden snake beneath a fallen log.  
I found so many items that I keep them all inside  
The pockets of my jeans.

#### **CHORUS**

Pockets, Pockets are so glorious.  
Pockets, Pockets are so glorious.  
There you find a lot of interesting things.  
My pockets are just fine!

# NOVEMBER 2004

## CUB SCOUT COLLECTORS

### Songs

#### WHAT'S INSIDE?

*(Tune: Supercalifragalistic)*

My Mother asked me one fine day just what I had inside.  
My pockets were so very full, they bulged from side to side.  
I told her that she didn't want to know the answer yet.  
For they are special things to me, my lifelong super pets.

A rubber ball, a piece of string, a candy wrapper too.  
Some bubble gum, a coke pop-top; Mom doesn't have a clue.  
But buried deep inside my pants; my very dear close friend.  
My horny toad will be my friend, until the very end.

#### An Alphabet Of Names

*(Tune: If You're Happy and You Know It)*

If your name starts with A, turn around.  
If your name starts with B, touch the ground.  
If your name starts with C, then stand up and touch your knee.  
Clap your hands if your name starts with D.

If your name starts with E, wink your eye.  
If your name starts with F, try to fly.  
If your name starts with G, blow a kiss up here to me.  
If your name starts with H, say "Hee, hee!"

If your name starts with I, wave your hand  
If your name starts with J, shout, "It's grand"  
If your name starts with K, stand and shout out loud, "We're here"  
If your name starts with L, tug your ear

If your name starts with M, make a smile.  
If your name starts with N, shake a while.  
If your name starts with O, put an elbow on your nose.  
If your name starts with P, say, "I know!"

If your name starts with Q, raise your hand.  
If your name starts with R, you should stand.  
If your name starts with S, you should pat your head, I guess.  
If your name starts with T, say "Oh, yes!"

If your name starts with U, touch your eye.  
If your name starts with V, pat your thigh.  
If your name starts with W, with X or Y or Z,  
Then stand up and take a bow and say "That's me!"

# NOVEMBER 2004

## CUB SCOUT COLLECTORS

### Skits

#### THE SPECIAL COLLECTION

*Cast: Six Cub Scouts, named Bobby, Bill, Tom, Jim, Danny and Mike and a Den Leader. A Cub Scout could play the Den Leader, if you wish. This skit is flexible so you can add or subtract parts to make sure every boy in the den has a part.*

*Setting: Cub Scouts are discussing their hobbies with their den leader at a den meeting.*

**Den Leader** All right boys, today I'd like you to answer roll call with the name of your hobby. Then we'll see if we can learn the scientific name for that hobby. Bobby, you're first.

**Bobby** I collect coins. I think that's called numismatist!

**Den Leader** Very good, Bobby. Bill, you're next.

**Bill** Well, we collect stamps in my family. And I've heard my dad called a philatelist.

**Den Leader** That's right, Bill. Now Tom, what's your hobby?

**Tom** My brother and I like to hike and watch birds. That's called an ornithologist.

**Den Leader** That's right, Tom. Very interesting. Jim, what do you collect?

**Jim** My dad and I collect fossils. That's called a paleontologist.

**Danny** *(Waving his hand)* My brother and I have a garden. We grow things scientifically. We're horticulturists.

**Den Leader** That's good Danny. And now Mike, what kind of special hobby do you have?

**Mike** *(Scratching head)* Well, I don't have a special hobby, but I bet you'll never guess what my dad collects! It doesn't have a fancy name. *(Grins a little. Other boys look at each other, whisper and shrug shoulders.)*

**Den Leader** We give up, Mike. What kind of collector is your dad?

**Mike** I knew you'd never guess. He's a BILL COLLECTOR!

**ALL** *(All clap hands to foreheads and leave.)*

# NOVEMBER 2004

## CUB SCOUT COLLECTORS

### Skits

#### **The Disappearing Banana** Northwest Suburban Council

- Equipment:** 4 or more bandannas and 1 very ripe banana
- Personnel:** 5 (or more) deadpan assistants and an announcer
- Setting:** Tell the audience that a magic trick is going to be performed for their enjoyment. Before their eyes, the assistants will demonstrate the disappearing bandanna trick. The assistants have been carefully selected for their ability to follow instructions exactly for their ability to follow instructions exactly. (The assistants take their places behind the announcer. Bandannas are concealed in the hip pocket. The banana is carefully kept behind the "dolt's back.)
- Announcer:** (Straight face at all time) "Remove the bandannas from your pockets and show them to the audience." (Assistants hold the bandannas in front of them, showing both sides. The one with the banana shows the banana with confidence.)
- Announcer:** "Fold the bandanna in half. (Everyone folds their bandanna one time. The one with the banana begins to look concerned, rolls his eyes left and right and then looks skyward. With an 'oh, well', attitude, he breaks the fruit in half.)
- Announcer:** "Fold the bandanna in half again." (Everyone folds their bandanna again to a smaller square. The one with the banana expresses more concern, looks left and right, uses facial expressions to demonstrate an uncomfortable feeling---remember to keep a straight face. He breaks the banana again.)
- Announcer:** "Hold the bandanna in your left had and fold the four corners in." (Everyone complies. The one with the banana sort of scoops up the fruit and piles it in the center of the palm of the left hand. Facial expressions should be indicative of extreme concern that something he is doing is different from everyone else.)
- Announcer:** "Make a fist!" (By now, everyone in the audience is watching the banana. The hands with the folded bandannas are discreetly exchanged--left for right--and the bandannas are placed in hip pockets. By now, the banana is oozing from between the fingers, and the audience is usually in tears.)
- Announcer:** "Open your hand, and show that the bandanna has disappeared. (Of course, it has, and applause is appropriate.)

# NOVEMBER 2004

## CUB SCOUT COLLECTORS

### Skits

#### **Making A Cub Scout** York Adams Council

This is an excellent opening for the induction/introduction of new Cub Scouts into a Pack.

**Characters:** Child, Two Leaders, Two Parents

**Props:** You will need a large table for the child to lie on during the “operation.” The “doctor” can carry a large cardboard knife. Props to be “removed” are tacked to back of table, out of sight. Those to be “put in” can be placed nearby. (Props are listed where used.)

**Narrator:** We are about to instruct you in the method of making a Cub Scout. To complete this project, you will need one small eager boy, two interested parents, one patient Den Leader, and one courageous Cubmaster.

(Each character enters as his name is spoken. Boy wears uniform under a large loose-fitting shirt and climbs up on the table. Others don surgical masks. As the narrator continues, the operation proceeds, with Cubmaster acting as doctor. Den Leader and parents hand him the things to be put in and take the things removed. When the boy is hidden under a sheet, he removes his shirt.)

**Narrator:** Cover him with fun and good times (Hold up posters labeled “FUN” and “GOOD TIMES” and cover boy)

We use laughing gas for anesthetic. (Use a tire pump labeled “Laughing Gas.”)

Take out hate and put in Love. (Hate - lump of paper, so labeled. Love - big paper heart, labeled).

Take out selfishness, put in cooperation. (Sign “I,” sign “WE”).

Take out idle hands, put in busy fingers. (Idle - empty rubber gloves. Busy - glove full of flour.)

Take out laziness, put in ambition. (Laziness - rag; Ambition - blown up balloon.)

After this pleasant operation, we have a “CUB SCOUT.” (Remove the sheet. Boy, in uniform, stands up and gives the Cub Scout sign.)



# NOVEMBER 2004

## CUB SCOUT COLLECTORS

### Games

#### POCKET COLLECTIONS

Tell the boys ahead of time to wear a pair of pants that have pockets. Now go on a collecting walk. You can only collect what you can put in your pocket; pebbles, sticks, seed, interesting trash, bugs, etc. Come back to the meeting place and lay out your collection. Analyze what you have and separate it into some kind of order. Each boy has a turn talking about his best "pocket find."

Another game that you can include in your collection hike is Pocket Kim's Game. Give the boys a few minutes to study the collection and then cover them. Give each one a sheet to write out whatever he can remember. (Or, you can split the den into teams and let them go after it that way)\_

#### NAME AND TELL

Cub Scouts sit in a circle. The first player names a hobby beginning with the letter "A" and tells something about it, and so on, around the circle and through the alphabet. Examples: "A" is for autographs - ball players are the best. "B" is for bugs - they are creepy crawly, etc.

#### DOUBLE COIN BALANCE



Ask someone to balance two coins on the rim of a glass at the same time, using only one hand. Here's how to do it: Stand the coins against the side of the glass. Push them up the side with thumb and forefinger. Carefully work the coins over the rim and balance them.

### Advancement Ceremony

#### Pocket Ceremony

York Adams Council

As we all know, most boys begin their collections in their pockets. Cub Scouts takes this a step further and uses to pocket on the uniform as a place to build a collection. Here is a pocket - a very plain pocket - not very interesting, and it could belong to anyone. But wait, let's give this pocket to a Cub Scout.

[Narrator places Bobcat badge on pocket.]

Our pocket is turning into something with meaning. It represents a sense of belonging and will soon bring our Cub Scout knowledge, skills, enjoyment and good fellowship. We would like to present the following boys and parents their Bobcat badge.

[Narrator places Wolf & arrows on pocket.]

With the Wolf rank, our pocket turns into something more special. It proudly displays the first symbol of new-found knowledge of the flag, of keeping strong, of tools, of knots of safety, of books and reading. It means our Cub Scout has mastered feats of fun. Tonight we are privileged to recognize the following Cub Scouts who have achieved the rank of Wolf. Would the following Wolf candidates and their parents please come forward.

# NOVEMBER 2004

## CUB SCOUT COLLECTORS

[Narrator places Bear & arrows on pocket.]

Adding the Bear badge has increased our pocket's meaning even more. It shows our Cub Scout is completing increasingly difficult achievements which show he is growing in knowledge and skill. Would the following Bear candidates and their parents please come forward.

[Narrator places Webelos and Arrow of Light on pocket.]

Our pocket has now had placed upon it the Webelos badge and Arrow of Light, the highest awards which our Cub Scouts can achieve. To receive these awards, our Cub Scouts must dedicate themselves to the hard work necessary in completing the required number of activity badges and prove themselves ready to join the ranks of Scouting. Tonight we wish to recognize these boys who have completed activity areas within the Webelos program. Will the following boys and their parents please come forward.

(With the Webelos Scouts together, a candle ceremony may be added at this time.)

Our pocket is very special now. It is very rich in new possibilities. It opens up a whole new world of challenges. Cub Scouting has taken our plain pocket, and turned it into a pocketful of adventure, fun, and excitement.

Congratulations to all you boys and your parents on your achievements.

### **Pocket Ceremony #2**

York Adams Council

*(Prepare pockets of blue paper with different emblems on them ahead of time and hold up as each is referenced in speech).*

Young boys and collections—I don't think they can be separated. Their collections hold the treasures of their lifetimes, yo-yos, a shooters and aggies, a few baseball cards, and Canadian pennies. When a boy walks home from school anything of interest goes into his pocket to become part of his clection - stones, pine cones, nails, a rusty bolt. What neat stuff!

Unlike other boys' pockets, the pockets of the Cub Scout's uniform cannot only hold a lot of things, they are used to display a boy's accomplishments. Cub Scout achievements can be divided into four categories: God, Country, Family and Self.

A boy can earn separate awards for all these areas:

For God, he can earn the emblem of his faith;

For Country, the World Conservation Award;

For Family, the Cub Scout Family Award;

For Self, the camp, special events, and sports/academic program patches.

The most important part of this colorful shirt is the rank; Bobcat, Wolf, Bear, Webelos, and Arrow of Light. Tonight we have someone/boys who has/have earned...

Present awards to parents to give to boys.

Give boys and parents a round of applause for a job well done.

# NOVEMBER 2004

## CUB SCOUT COLLECTORS

### Run On/ Applause

#### RUN ON

Cub enters Singing – “Soap.. . soap. . soap”

Cubmaster asks – “What are you doing?”

Cub replies – “Oh, just singing a few bars!”

Why was the turkey the drummer in the band?

*Because he had drumsticks!*

Why did the Pilgrims want to sail to America in the spring?

*Because April showers bring mayflowers!*

What key has legs and can't open doors?

*Turkey!*

If April showers bring May flowers what does May flowers bring?

*Pilgrims!*

#### Stick Stunt

**Boy:** (Comes on stage with stick in his hand. He puts the point of the stick down on the floor, picks it up, puts it down in another place.)

**Leader:** What are you doing?

**Boy:** Oh, I'm just sticking around.

#### Knock, Knocks

*Trapper Trails Council*

Knock, Knock

Who's there'?

Would he

Would he who?

Woody Woodpecker (do Woody Woodpecker call)

Knock, Knock

Who's there?

Ketchup

Ketchup who?

Ketchup to me if you can

Knock, knock

Who's there'?

Thistle

Thistle, who?

Thistle, be the last Knock, knock joke.

# NOVEMBER 2004

## CUB SCOUT COLLECTORS

### APPLAUSES

**TURKEY 1** - Say, "Gobble, gobble, gobble," then rub stomach and say, "Yum, yum."

**TURKEY 2** - Put hands under armpits to make wings, flap wings and yell, "Gobble, gobble, gobble."

Trapper Trails Council

**Sword** - Pretend to have a sword in your hand. Swing it across your body three times saying, "Swish, swish, swish!"

**The Wave** - Rise and raise arms above head then sit back down. (as done at sports events)

**Cheese grater** - Act as if you are grating cheese and say "Great, great, great, great!"

**Palm Tree** - Stand like a tree with palms up.

### AUDIENCE PARTICIPATIONS

#### THE CUB KNOT STORY

Divide audience into four groups and assign each a part. They are to say the phrase for their part every time they hear it in the story.

**ROPE:** I'm fit to be tied  
**DEN MEETING:** Paint; cut; glue  
**KNOT:** Cross arms in front and say "What Knot?"  
**CUB SCOUT:** Where's the cookies?

For those of you who can't imagine that a ROPE can come alive, this story may be hard to believe. Once there was a four-foot piece of ROPE who wanted to become a CUB SCOUT. The ROPE knew that in DEN MEETINGS, CUB SCOUTS learned to tie KNOTS in ROPES. And he had always wanted to learn how to tie himself into a KNOT. So the ROPE checked with a CUB SCOUT he knew to find out when the next DEN MEETING was to be held. He put on his best tie; hitched up his pants and headed for the meeting. The ROPE could tell that he was at the right house, because several CUB SCOUTS were arriving to begin the DEN MEETING. The ROPE walked right in and said to the leader, "I want to be a CUB SCOUT and attend your DEN MEETINGS." But the den leader said, "I can KNOT let a ROPE be a CUB SCOUT!" Well, the ROPE was really upset. He ran out of the DEN MEETING, KNOT knowing what to do next. He ran out into the gravel road and was run over by a bread truck. The ROPE was tumbled, rolled, crunched and, in general, pretty messed up. His ends were all unraveled and he had been twisted into a quadruple half hitch KNOT! The ROPE couldn't even remember who he was. But somehow, he remembered he wanted to be a CUB SCOUT and that a DEN MEETING was going on that he should be attending. He stumbled to the front door and knocked. The CUB SCOUT den leader halted the DEN MEETING to answer the door. When the den leader opened the door, there was the unraveled half hitched ROPE. "I want to be a CUB SCOUT," said the ROPE. The den leader looked at him and said, "Aren't you the ROPE that was here a few minutes ago?" The ROPE looked right at the den leader and shouted, "I'm a frayed KNOT!"

# NOVEMBER 2004

## CUB SCOUT COLLECTORS

### AUDIENCE PARTICIPATIONS

#### How To Build A Thingamajig

York Adams Council

Divide audience into four groups and assign each a part.

They are to say the phrase for their part every time they hear it in the story or whenever they hear Scatereekus.

**Doodads:** Clickety-clack, clickety clack  
**Dingford:** Whiz, bang, boom  
**Freedistant:** Whoosh, whoosh  
**Higoricky:** Snap, crackle, pop  
**Scatereekus:** All sounds together

Very few families these days can get by without a thingamajig. Sure you can buy one at the local hardware and appliance store, in all sorts of colors, sizes, shapes, makes and models, but as easy as they are to build yourself, you should just get a kit and put it together. Here are a simple set of instructions for building your own thingamajig...

The **Doodads** of the thingamajig kit are stored in the bubble-wrap gizmo and are stapled with the purple assembly **Dingford** to the left-handed **Freedistant**. The assembly **Dingford** should be placed in an upright position on any corrugated doomaflatchy or **Freedistant** to complete assembling the **Doodads**. Carefully remove the gizmo from its containeration of the **Doodads** from the **Freedistant** and lay out the **Doodads** in parallel with the assembly **Dingford** and assemble the **Doodads** in the order listed. You will need two fringhoppers with a 4/3" gagglehump for the **Higoricky**, and you'll have to use penpoppers to complete the riggeration.

Using a witchifiggle, carefully punch 1/2" what-nots through the assembly **Dingford** and **Freedistant**, where the **Higoricky** will attach. The what-nots are there to capitrate the hoosie **Higoricky** that will beefling the **Doodads** together.

Next framemis the chingus to the **Freedistant**, making sure the whatchamacallits are catiwompus to the hootnanny and the **Higoricky**, as shown on the assembly **Dingford**. If it is reversed, the thingamajig will not work properly.

Tighten two fistaroud valves underneath the **Freedistant** using the hickeyes from the **Doodads** to on from one doodad to the other. Now refracker a jigger to the the demisantis and the doorfunkey near the whatchamacallits. Put a dingus on each loose enough so that the thingamabob can discombobulate and rotate easily, or it might XXXX and fly off and hit someone in the doohickey.

That finishes the instructions. If you've followed them carefully, you should have a well running thingamajig. When you turn over the **Scatereekus**.

# NOVEMBER 2004

## CUB SCOUT COLLECTORS

### Closing

#### Pocket Collections

Heart of America Council

**Personnel:** 7 Cubs

**Equipment:** Cards with letters spelling out **P O C K E T S** and pictures of collections.

**Cubmaster** As we have seen at tonight's Pack Show, cub Scouts collect many things. Let's have a recap before we go home -

**Cub # 1.** **P:** is for **POSTAGE** stamps, something people have collected for many years.

**Cub # 2.** **O:** is **OLD-FASHIONED**, what some call antiques.

**Cub # 3.** **C:** is for **CARDS**, baseball, football, basketball or hockey. There are so many kinds to choose from.

**Cub # 4.** **K:** is for **KITES**, to fly high in the sky. They come in so many styles and color the variety is endless.

**Cub # 5.** **E:** is for **ELECTRONICS**, some people collect everything electronic they can get their hands on. TVs, radios, CD players, video games and computers the list goes on.

**Cub # 6.** **T:** is for **TOYS**, every kid is a true collector. Their collecting never stops even when they grow up. They just collect different toys.

**Cub # 7.** **S:** is for **SCOUT** stuff, that every Scout collects. What Scout does not have collections of badges, patches, uniforms, ties slides, T-shirts, and camping gear.

**Cub # 8.** Thanks for coming. Hope you enjoyed the show. Good night

### COLLECTIONS THOUGHT

*Contributed by Scott Thayer, Sequoia Council, California*

*And Sam Houston Area Council*

Many people of all ages have discovered the fun of collecting things. Whether you collect rocks or stamps or model cars, it's exciting to be on the watch for a new item to add your collection and to see that collection grow. Some collections, such as rare sports cards, can be worth a lot of money. Other collections have no great dollar value. But there is one thing that you can collect which is worth more than anything else; good turns. In the Cub Scout Law of the Pack, we say, "The Cub Scout gives good will." That means that a Cub Scout is always on the lookout for ways to be helpful and kind to other people. When you accumulate acts of good will toward others, you are the wisest collector of them all.

### Closing

Trapper Trails Council

Have Cubmaster pull out the collection of stuff he/she carries in his/her pockets and explain why it is carried and how it helps one be prepared for emergencies with it. Then conclude with -

**Cubmaster:** Everything a boy collects in his pockets or elsewhere is important to him, just as he and his family is important to our pack. We have to work together to be successful, if our pack is successful, each of us will feel good about ourselves and each other. Let's remember to be prepared by what we carry in our pockets and our lives and be successful.

# NOVEMBER 2004

## CUB SCOUT COLLECTORS

### After the Meeting

#### **Kangaroo Pocketful of Goodies**

Northwest Suburban Council

1/2 to 1 pocket bread per scout, 1/4 to 1/2-cup chicken or turkey per scout, tomato slices if they want, 1 TBS chopped walnuts, mayonnaise or salad dressing, lettuce, 1 slice cheese per scout

Slice the pocket bread in half (if using a whole per scout) open it. Spread mayonnaise or salad dressing in center. Add turkey or chicken and cheese slice. Cook in microwave for 30 - 40 seconds for 1/2 or 1 minute for a whole pocket. Insert slices, lettuce, and chopped walnuts.

#### **Hot Pockets (the easy way)**

Trapper Trails Council

1 package crescent rolls, Pizza Sauce, Pepperoni, Cheese

Cut up the pepperoni and cheese. Spoon a spoonful of pizza sauce on one crescent roll. Put some pepperoni and cheese in the center and fold over and smash edges together with a fork. Cook 375 degrees for 15 - 18 minutes You can also use the 'same idea for peanut butter and jelly, pie filling etc.

#### **Pita Sandwiches**

Trapper Trails Council

1 package Pita Bread, any meat and cheese lettuce pickles salad dressing, mustard (any other sauces) tomatoes

Cut Pita Bread in half, open up and spread salad dressing on both sides, add mustard, cheese, meat, pickles, lettuce, tomatoes, (and any other filling you like)

#### **Ice- cream Sandwiches**

Trapper Trails Council

Make your favorite peanut butter cookie recipe or buy peanut butter cookies - For each ice-cream sandwich, press 1 rounded tablespoon ice cream between 2 cookies. Put sandwiches in rectangular pan and freeze uncovered about 1 hour or until firm. If you would like roll the edges of the sandwiches in candies or chopped dry roasted peanuts. Wrap each sandwich in plastic wrap. Store sandwiches in freezer in plastic freezer bag.

#### **Baloo**

Saw this on TV. Most everyone likes pie. Here's a super easy pie that is not too sweet, and if you know how to stir you can make it. I really like this easy to do pie, since our Cubs typically are new to the kitchen, and this is a very easy pie which in my mind will boost confidence in a new area to them. If you think eating yogurt will \*gross-out\* your Cubs, make it for them first without telling them what is in it. Or just tell them some of the ingredients, whip cream, some fruit, and a cookie crust.

**Ingredients:** 1 container strawberry yogurt (the fruit on the bottom kind)

1 container mixed berries yogurt (the fruit on the bottom kind)

One-half of 8 oz. Container cool whip

ready made graham cracker crust (we used a chocolate cookie crumb pie crust)

Stir together well first three ingredients and pour into crust. Pop it into the freezer for approx. 3 hours.

# NOVEMBER 2004

## CUB SCOUT COLLECTORS

### Craftsman

### Two-Tone Code Whistle

You can work out a series of code signals with this two-tone code whistle. The twin tones make it penetrate a long distance. Each hole may be used independently or both may be blended.

Walnut, maple or birch are good hardwoods to use. Make sure the holes are completely free of sawdust. Round off all edges and sand it smooth, then attach a neck strap lanyard long enough so that you can tuck the whistle into your shirt pocket.

Note that the plugs are flattened off at the top. Plugs should make a tight fit for the best resonance.

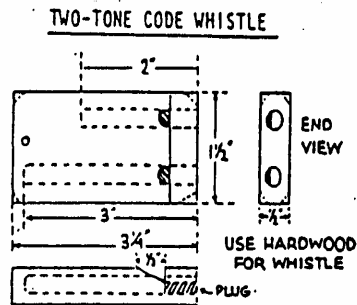

1. Drill holes as indicated in piece of hardwood. Cut air escape notch.
2. Insert 1/4-inch plugs flush to straight cut of notch. Cut off excess wood.

### Personal Bike Rack

**Materials:** One 14" x 18" piece of 1/2" plywood; one 1" x 2" x 2'; one 2" x 8" x 18" No. 6 flathead screws (1-1/4" long); six-penny nail; varnish or paint; white glue or powdered resin glue.

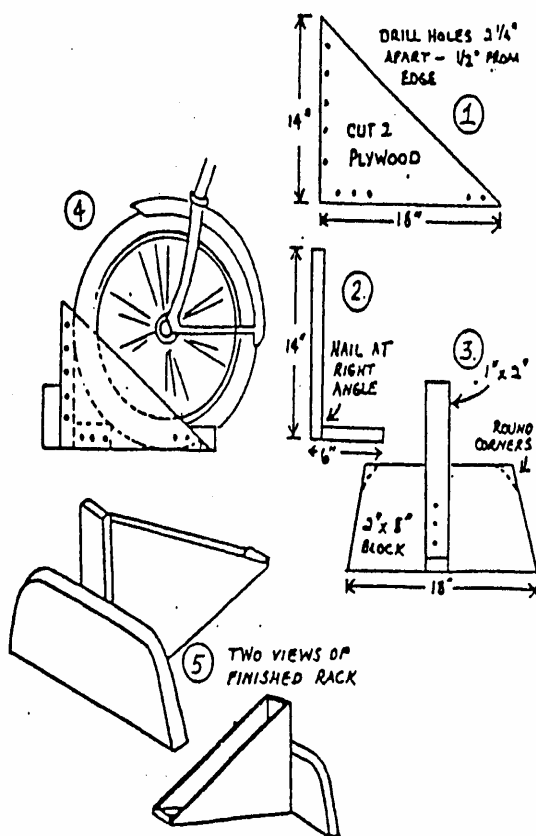

1. Cut plywood triangles. Drill holes as show with a 5/32" drill bit. Paint or varnish the inside of plywood at this time. It will be difficult to do after rack is assembled.

2. Cut the 1" x 2" pieces. Nail the two longest pieces at right angles.

3. Cut the 2" x 8" piece. Attach the nailed 1"x2" with screws. Paint or varnish the 1" x 2" now. (Note the right angle is fastened to the 2" x 8" with screws from inside.)

4. Fasten the plywood triangles in place with screws through pre-drilled holes. Don't forget the small piece of 1" x 2" that joins the tips of the triangle.

5. Sand and complete paint or varnishing the piece.



# NOVEMBER 2004 CUB SCOUT COLLECTORS

Craftsman

## PICTURE FRAME HOUSE

### Material list:

- 1 Floor  $\frac{3}{4}$ " x 2" x 6"
- 1 Back  $\frac{1}{2}$ " x 6" x 9  $\frac{1}{2}$ "
- 1 Rooftop  $\frac{1}{4}$ " x 2  $\frac{1}{2}$ " x 5  $\frac{3}{4}$ "
- 1 Rooftop  $\frac{1}{4}$ " x 2  $\frac{1}{2}$ " x 6"
- Cut popsicle sticks for fence
- $\frac{1}{4}$ " x  $\frac{1}{4}$ " sticks for picture frame

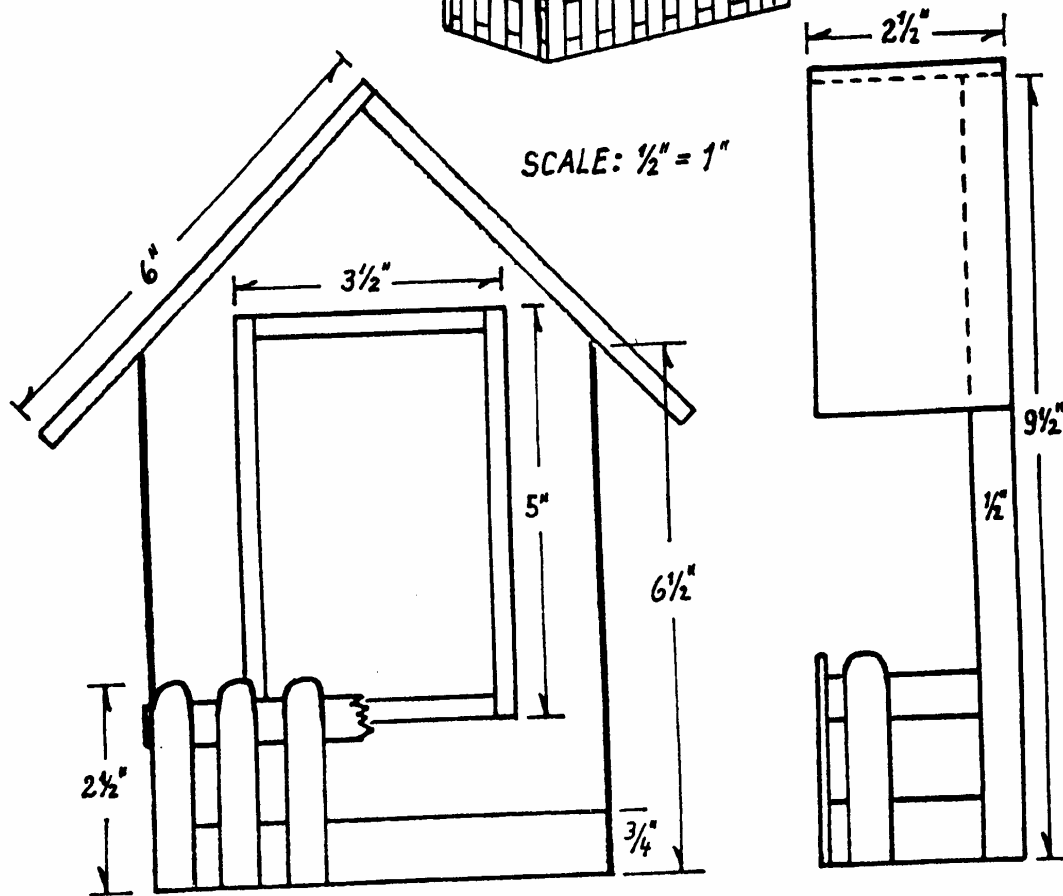
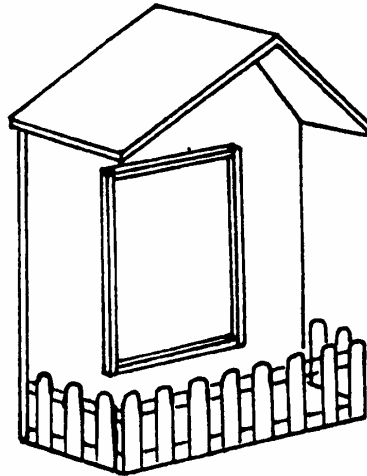

# NOVEMBER 2004 CUB SCOUT COLLECTORS Craftsman

## Carpenter's Level

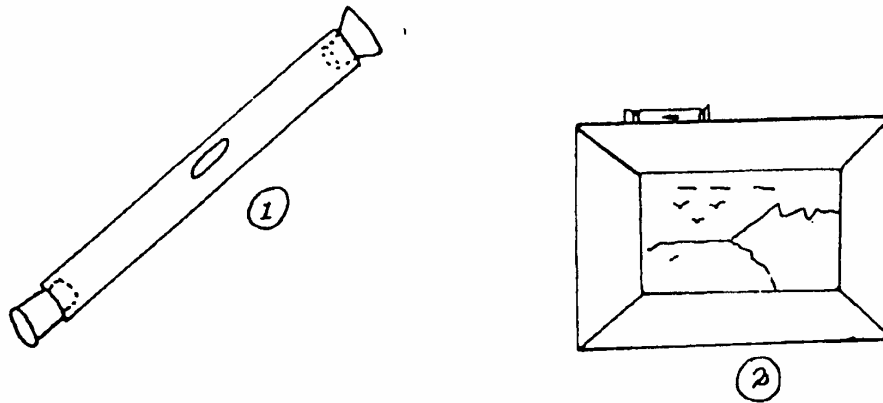

You can make a carpenter's level out of a glass tube - like dentists use or the kind of plastic tube a toothbrush comes in.

With the vile from the dentist's office, remove one rubber cork from the end. Rinse tube out good and then fill almost full of water and replace cork.

With a glass or plastic tube, cork one end, fill nearly full with water, then cork the end. (pic 1.)

Lay tube on a flat surface. If this surface is perfectly level, the bubble inside the tube will be exactly in the middle. If the surface is not quite level, the bubble will be off center one way or the other. (pic 2.)

## Book Trough

Trace diagram of book ends onto 3/8" board or plywood. Cut shelves from measurements. Make ends identical by clamping together before cutting and finishing.

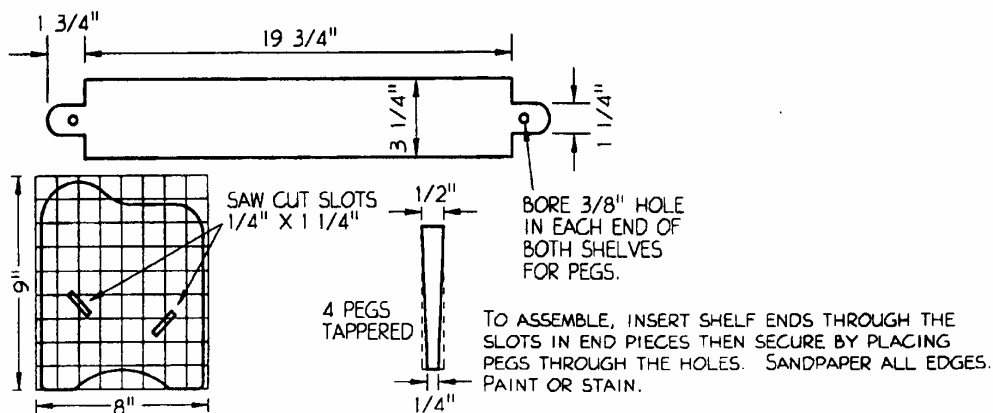

# NOVEMBER 2004

## CUB SCOUT COLLECTORS

### Scientist

#### DEN FIELD TRIP IDEAS

- ◆ Visit an eye specialist.
- ◆ Have school science teacher demonstrate an experiment.
- ◆ Visit an airport and ask expert to explain flight principals.

#### INERTIA

Inertia is the tendency of a thing at rest to remain at rest and a thing in motion to continue in the same straight line.

Get a small stick about 10-inches in length and the diameter of a pencil. Fold a newspaper and place it near the edge of a table. Place the stick under the newspaper on the table and let about half the stick extend over the edge of the table. Strike the stick sharply with another stick. Inertia should cause the stick on the table to break into two parts.

#### PASCAL'S LAW

##### *Materials:*

*Rubber balloon*

*Several pins with large heads*

*Roll of plastic tape*

Inflate the balloon and affix little squares of plastic tape to it. Stick each pin through the center of the tape and to their amazement, the balloon will not burst. When you remove the pins, the balloon still will not burst.

##### *WHAT HAPPENS:*

The adhesive substance on the tape acts like a self healing automobile tire, adhering to the pin as it is pressed inward. When the pin is removed, the adhesive is forced outward by the air pressure from within the balloon, atomically sealing the tiny pinholes.

#### MYSTIC MATCHES

1. Put several matches in a bowl almost full of water, making a shape like a star.
2. Stick a pin into a small piece of soap.
3. Gently dip the soap into the water at the center of the star of matches, taking care not to disturb them. The matches will all move away from the soap.

##### *WHAT HAPPENS:*

When you dip the soap in the water a little of the soap dissolves. The surface tension of the clean water is stronger than that of soapy water, so the clean water around them pulls the matches outward.

# NOVEMBER 2004 CUB SCOUT COLLECTORS

## Scientist

### MAKE A FIRE EXTINGUISHER

Materials needed: 1 or 2 quart bottle with stopper to fit  
3" of ½ " glass, metal or plastic tubing  
(Tube from an old Windex bottle can be used)  
Spoonful of baking soda  
Vinegar  
Facial tissue

Drill hole in stopper and insert tubing  
Wrap soda in tissue and attach tissue to tube with rubber band  
Fill bottle one half full of 1 part vinegar and 1 part water  
Insert stopper in bottle with soda inside bottle, but not touching vinegar solution  
To operate, tip bottle upside down, soaking the tissue paper with vinegar

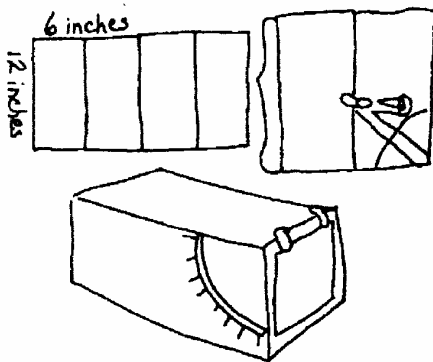
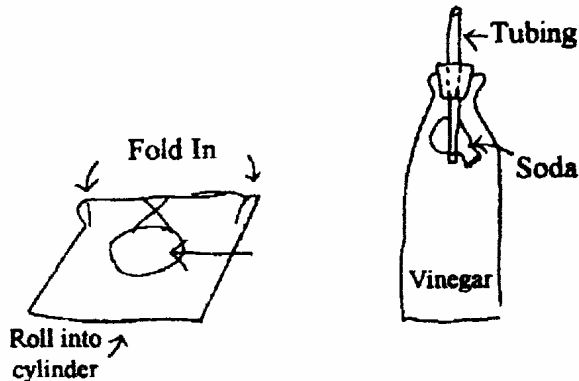

### RECORD WIND SPEED

To see how fast or slow the wind blows, make an anemometer (a wind speed measurer) You will need stiff cardboard 24" x 12"  
Measure four 6" widths with a ruler, and draw pencil lines with scissors.  
Set a compass to 4" and draw an arc on the cardboard as shown.  
Cut out a narrow slot along the arc.  
Cut out a narrow slot along the arc.  
Mark numbers at equal intervals along the slot.  
Fold the cardboard inward along the scored lines.  
Put cellophane tape along the two edges and along all the folded edges.

Cut a piece of paper 4 ¾" square and tape it to the end of the box as shown. Take the anemometer outside and point the flap toward the wind. Each night and morning, record the level that the flap reaches

# NOVEMBER 2004

## CUB SCOUT COLLECTORS

### Scientist

#### **BALLOON IN BOTTLE**

Place a deflated balloon inside a two-liter bottle, with the lip of the balloon over the top of the bottle. Try to blow up the balloon. What happens? Air pressure inside the bottle increases as the balloon takes up space, so air pressure is fighting against you. To inflate the balloon, you would need to compress the air trapped between the balloon and the bottle. To compress air requires force. The human lungs are not strong enough to inflate the balloon and to compress the trapped air.

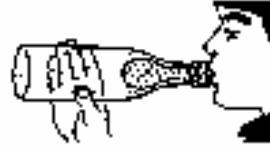

#### **BOILING ICE**

In a heatproof jar with lid, boil a half-inch of water with the lid on loosely so some of the steam can escape. Then tighten the lid and turn jar over. Put an ice cube or two on the jar bottom. In a moment the water will boil again.

#### *WHAT HAPPENS:*

The air pressure has been reduced in the jar by the ice condensing the water vapor inside. The boiling point of a liquid depends on atmospheric pressure.

#### **BALLOON AND CAN RACE**

Each team will need a balloon for every Webelos and a fruit can for each team. Each team will have a chair on each end of the room. Each team is divided with half of the team behind each of that teams chairs. The can is placed on a chair.

One boy holds the balloon in the can and blows it up enough to make the can stick on around the balloon. He then carries the balloon, with the can hanging on, to the other chair. He then deflates his balloon and the next boy inflates his own balloon and carries it and the can back to the original chair. The first team to switch locates wins.

#### **EXPERIMENT IN AIR PRESSURE**

#### **SHOOTING BACK**

Place an empty soda bottle on its side. Put a wad of paper in the neck and try to blow it in. It comes back out. Why? When you blow into an enclosed space like a bottle, you increase the air pressure inside. Since pressure will equalize when it can, the air rushes out of the bottle, taking the wad of paper with it.



# NOVEMBER 2004

## CUB SCOUT COLLECTORS

### Scientist

#### EXPERIMENT IN AIR PRESSURE *continued*

If we compress air (put more air into the same space), we will increase its pressure and can use it in machines. Your bike tires use compressed air to give you a smooth ride.

##### Making Air Work for Us

Use a balloon to pick up a glass -- Place a deflated balloon in a glass. Blow up the balloon until it is tight around the edge of the glass. Hold the end of the balloon shut and pick up the glass. Use a balloon to lift books -- Place a deflated balloon under a stack of books. As you blow the balloon up, the books will rise. A hydraulic lift is based on this principle.

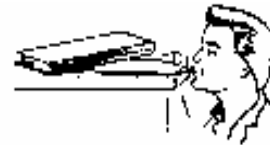

#### EXPERIMENTS IN ATMOSPHERIC PRESSURE

We live under a blanket of air called the earth's atmosphere. The air in the atmosphere exerts pressure of almost fifteen pounds per inch on every surface on earth.

#### DIVING BELL

Place a piece of crumpled paper in the bottom of a glass or tin can. Turn the glass upside down and submerge it in a bucket of water. The paper will remain dry. Why? The air, which filled the "empty" space in the glass, stopped the water from entering.

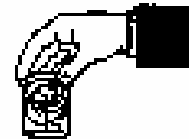

#### HANGING WATER

Fill a glass to overflowing and lay a piece of cardboard atop it. Support the card with one hand, turn the glass upside down, and remove your hand from the card. The card does not fall. It remains on the glass and allows no water to escape. Why? The air pressure from below the cardboard is greater than the pressure of the water above and presses the card tightly against the glass.

#### WEDGED GLASSES

Place two glasses together with a piece of wet construction paper between them. Burn a candle in the bottom glass. The glasses become "welded" together. Why? The flame uses up the oxygen in the bottom glass, so the pressure is now lower in this glass.



# NOVEMBER 2004

## CUB SCOUT COLLECTORS

### Tigers - Making My Family Special Family Activity

- ◆ Turn off the TV and have a Family story time.
- ◆ Plant a garden - each family member chooses a veggie to plant.
- ◆ Take a walk around the neighborhood or park.
- ◆ Play a board game together.
- ◆ Make cookies.
- ◆ Have a backyard campout.
- ◆ Choose toys not played with anymore to donate to abuse shelter, church nursery, etc.

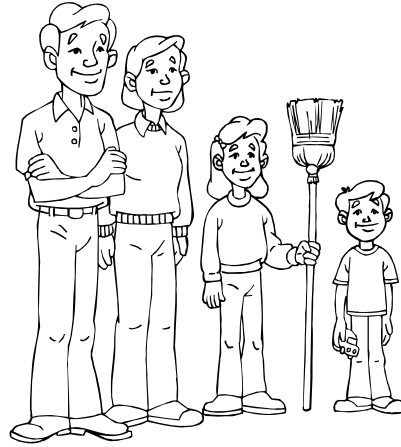

#### **FAMILY PHOTOGRAPHS**

Make a collection of family photos starting with recent ones and going back to the oldest ones you can find. Ask all of your family members to contribute to your project. Look at the pictures closely to see how the hair and clothing styles have changed over the years. Don't forget to look for resemblances. WHO DO YOU LOOK LIKE?

#### **Den Activity**

##### **WHO IS MY IMMEDIATE FAMILY**

##### **MATERIALS:**

*Paper*

*Crayons or markers*

##### **DIRECTIONS:**

1. Arrange boys in a circle.
2. Ask them each the following question: An activity I like to do with my family is\_\_\_\_\_.
3. Have boy's think about who is in their family. i.e.: Mom, Dad, brother, sister, grandparents' cousins' etc. List these names for the boys to see. Ask the following two questions:  
Which people live with you? Those are immediate family.  
Which people live elsewhere? Those are extended family.
4. Pass out paper and crayons or markers.
4. Have boys draw an immediate family portrait with their partners help. Remind them to include only immediate family members.

**\*\*Be prepared to discuss diverse family living situations, i.e. single parents, parents and sufficient other living together, grandparents raising children, etc.**

# NOVEMBER 2004

## CUB SCOUT COLLECTORS

### Tigers - Making My Family Special

#### ACTION SELF PORTRAITS

Tape together sheets of freezer or butcher paper that are at least 3 times as long as you are tall. Lie down on the paper and “strike a pose”. Hold it and have someone trace all around you with a black crayon while you hold still. Get up and then decorate your body outline. Draw on fancy clothes or a funny costume etc.

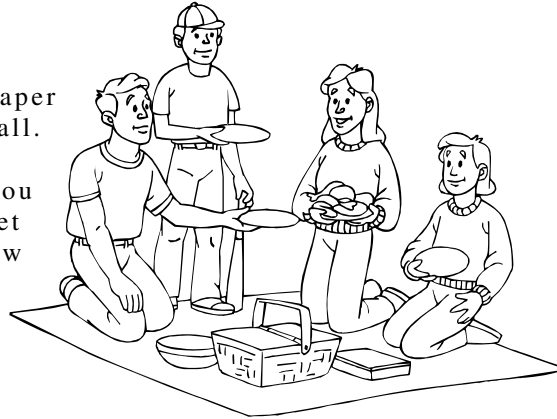

#### KNOW YOUR FAMILY

Have each boy bring several pictures of his family. Sit in a large circle and play “Hot Potato”. A potato is passed around to music and whoever has the potato when the music stops gets to tell the story behind his pictures.

#### ADDITIONAL IDEAS

- Make and share your family's favorite snack.
- Discuss your families favorite vacation or travels. Mark the areas on a map.
- Play a favorite family game. Keep in mind any safety issues if playing an action sport. Include the partners in the game.

#### Go See It Outing

- Go to a Library
- Historical Society
- Museum
- Old Farm or historical building
- Visit an older person in the community or church



# NOVEMBER 2004

## CUB SCOUT COLLECTORS

### Cubmaster Corner - Scouting Good Turn (Scouting for Food)

#### National BSA Good Turns - ORIGIN

The Boy Scouts of America's Good Turn traces back to American businessman William D. Boyce who was lost in a London fog. A boy offered to take Boyce to the address he wanted and refused a tip, saying he was a Boy Scout. Boyce's curiosity was aroused. He later had the boy take him to Scouting's British founder, Lord Baden-Powell. From this chance meeting, the Boy Scouts of America was born.

Among many references to the Good Turn in BSA literature is this comment from the Boy Scout Handbook: "To people who know about Scouting, the daily Good Turn is one of the finest features of our movement. The record of Good Turns, small and large, that have been done by Scouts since the day Scouting was founded is truly impressive."

#### NATIONAL GOOD TURNS

The following list is compiled from the BSA's historical fact sheet and from Bob Peterson's book *The Boy Scouts, An American Adventure*. There is some inconsistency, and, on many of the earlier Good Turns, there is a certain degree of uncertainty as to whether the event was planned as a national program or just developed that way. In any case, here is a chronological listing.

1912-The first Boy Scout Good Turn promoted a "Safe and Sane Fourth of July."

1917-The day after war was declared on Germany, under the slogan "Every Scout to Feed a Soldier," BSA members were urged to plant vegetable gardens. In two plant-growing seasons, 12,000 Scout farms were established. At the same time, the BSA pledged to aid the American Red Cross and promised cooperation with the U.S. Navy by organizing Scout coastal patrols to watch for enemy ships. The BSA's most significant service during WWI was the sale of Liberty Loan bonds to help finance the war effort. Five bond drives were held, and, in each case, Scouts were called upon to follow up the regular canvas by adult volunteer salesmen. They sold a total of 2,238,308 bonds worth either \$147,876,902 or \$355,000,000, depending on the information source. Scouts also sold war savings stamps to a value of either \$3 million or \$53 million, again depending on the source. During WWI Boy Scouts collected peach pits and nut hulls which were burned to make charcoal for gas mask filters. More than 100 train carloads were gathered. Another WWI Good Turn involved a national census of standing black walnut trees. Its wood was prized for gunstocks and airplane propellers. The BSA located 21 million board feet, or enough to fill 5,200 railroad cars. Scouts served as dispatch bearers for government agencies and delivered 30 million (or 300 million, depending on source) pamphlets during WWI. Scouts also aided the American Red Cross and the United War Work Committee.

1934-President Roosevelt called on Boy Scouts to collect household furnishings, clothing, and other items to help the needy during the Depression. More than 1.8 million articles were collected. During WWII the BSA responded to 69 requests for help from the government. These requests included: 1941-Scouts distributed 1.6 million defense bonds and stamp posters; began the collection of aluminum and waste paper; conducted defense housing surveys; planted victory gardens; distributed air-raid posters; cooperated with the American Red Cross; and, by agreement with the Office of Civil Defense Mobilization, formed an Emergency Service Corps composed of older Scouts who served in three capacities: messengers, emergency medical unit assistants, and fire watchers.

# NOVEMBER 2004

## CUB SCOUT COLLECTORS

### Cubmaster Corner - Scouting Good Turn (Scouting for Food)

1942-Scout projects included: delivery of millions of war-bond pledge cards-it was estimated they were indirectly responsible for sales of \$1.8 million worth of bonds and stamps; collection of a vast amount of rubber, primarily old tires, estimated at either 5,898 tons or 30 million pounds; and continuation of scrap and paper drives. During the first drive, Scouts collected 5,000 tons of aluminum; other sources added another 17,400 tons of tin cans and 20,800 tons of scrap metals.

1944-Boy Scouts were sent to collect milkweed floss as a substitute for the kapok used in life jackets-total collection was 750 tons. An estimated 184,000 victory gardens were planted by Scouts. An estimated 126,000 Boy Scouts helped farmers with their harvests. The largest single war-effort project conducted by the BSA was the 1945 General Dwight D. Eisenhower Waste Paper Campaign. More than 700,000 Boy Scouts and Cub Scouts gathered 318,000 tons of paper; this brought the total paper collected during WWII to more than 590,000 tons. Scouts collected 10 million used books for military personnel. Scouts collected 7,000 tons of used clothing that was distributed to refugees in Europe and China.

1950-51-Two million pounds of clothing for overseas relief was collected at the request of the American Council of Voluntary Agencies for Foreign Service and the United Nations.

1952-More than 1 million boys went house-to-house and placed 30 million Liberty Bell doorknob hangers and a million posters (in businesses) to remind citizens to vote in the presidential election. Scouts also cooperated nationally in securing blood donor pledges, collected clothing for worthy causes, distributed seeds for Asia, and aided in conservation projects and civil defense.

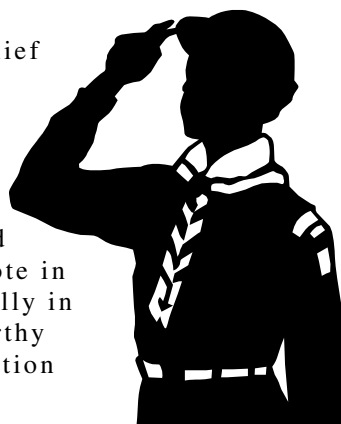

1954-A National Conservation Good Turn involved the distribution of 3.6 million copies of a conservation poster. In parks, rural areas, and wilderness areas, Scouts planted 6.2 million trees; built and placed 55,000 bird-nesting boxes; and arranged 41,000 conservation displays.

1956-The second national get-out-the-vote campaign was launched with 36 million doorknob hangers and 1.4 million posters distributed.

1958-National Safety Good Turns were conducted. The BSA delivered 40 million emergency handbooks prepared by the Office of Civil Defense Mobilization. Also, 50,000 posters were placed in post offices.

1960-The third national get-out-the-vote campaign was conducted.

1970-Project SOAR (Save Our American Resources) was initiated as an ongoing BSA project. It's estimated that during the year, 60,000 BSA units took part in SOAR-related conservation projects.

# NOVEMBER 2004

## CUB SCOUT COLLECTORS

### Cubmaster Corner - Scouting Good Turn (Scouting for Food)

1980-Scouts distributed fliers urging support of the national census.

1986-An estimated 600,000 youth members distributed 14 million brochures to families informing them of the need for donated human organs and tissue and urging them to make a commitment to donate. Millions of other homes were reached through publicity and other promotional efforts.

1988-The first Scouting for Food collection was completed. One million Scouts collected an estimated 65 million cans of nonperishable food.

1989-1991-The continuing Scouting for Food collection resulted in a combined total of an additional 209 million cans of food for people in need.

In 2000 the Boy Scouts of America committed itself to donating 200 million hours of community service as part of its support for "America's Promise" campaign.

### What is Scouting for Food?

A Cub Scout promises to "give good will" and a Boy Scout promises "to help other people at all times." What better way is there to show our Scouting Spirit than by participating in the annual Scouting for Food drive?

Over the years, the Circle Ten Council Boy Scouts of America has worked diligently to improve our communities and the welfare of the families who reside in these communities. One very special project conducted by our Council has grown to be extremely important to many agencies, families and individuals. This "Good Turn" Event is known as the Scouting for Food Campaign.

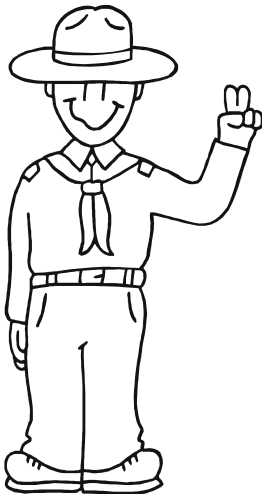

The mission of the project is to have all Scouts participate in the collection of food items to be given to needy people and families within the communities of the council. The goal is to have 100% participation from all units in this most important community outreach program. Cub Scout Packs, Boy Scout Troops, Varsity Teams, and Venturing Crews do make a difference when they support and participating in this annual Good Turn.

#### How can you help?

- You can distribute and then collect the bags of food left on the porches and steps, from around your neighborhood.
- Man collection sites
- Help unload food drive items at the Network of Ministries, Salvation Army sites or Food Bank locations.

**CONTACT your council or district Food Drive chairmen for more details and a listing of assignments available.**

# DECEMBER 2004 HOLIDAY FOOD FARE



Foods help to keep our bodies strong and healthy, and are often a major part of our holiday celebrations. Compare the labels of different foods to learn more about the nutrients they contain. Cub Scouts can use different types of foods to make crafts and holiday decorations to share with others. Experience foods from other countries or prepare delightful treats to share with your family, a needy family or an elderly resident. Have a family or a den dessert contest at the pack meeting. Awards could include the Best Bean Award, Top Carrot Award, or other imaginative categories.

Cub Scout Theme .....03

## **Holiday Food to Make in Your Den and Enjoy!!..... 29**

Webelos – Craftsman.....33

Webelos – Scientist.....35

Tigers - Where I Live .....38

Cubmaster Corner - The L's...Learn, Laugh, Lead.....40

# DECEMBER 2004

## HOLIDAY FOOD FARE

The 3rd World Jamboree was held at Arrowe Park, Birkenhead, England in 1929. It was known as the "Coming of Age" Jamboree as it celebrated 21 years since the foundation of the Scouting Movement.

### COMING OF AGE, 1929

From R. H. Kiernan, *Baden-Powell*, 1939

The great movement which Baden-Powell had founded and nurtured came of age in 1929, when the occasion was celebrated by a World Jamboree held at Arrowe Park, near Birkenhead, where a campsite of 450 acres was provided free of charge.

By ship, rail, airplane, and road the Scouts moved towards Arrowe Park. Indians walked a hundred miles through mountain and jungle to reach railheads; Germans hiked from Grimsby; poor English Scouts reached Birkenhead on foot from great distances; and some Americans arrived from Plymouth by a trek in a covered wagon. The camp was a mile long by half a mile broad, and 56,000 Scouts of all nationalities camped together. 1,500 Americans marched with the Stars and Stripes, accompanied by contingents from the Dominions and Colonies, black, brown, and yellow, under the Union Jack; red fezzes, kafiye, turbans, and the varied headdresses of the European countries mingled together. The different nations acted scenes from their history—Sioux war dances, Irish battles of heroes, Caractacus and the Druids of Wales, and the Belgians' play of St George and the Dragon. There was again the wonderful dancing of the Scots, a Wolf Cub display, and all the demonstrations of handicraft, bridge building, first aid, and physical training. Campfire sing-songs, concerts, and cinema shows were organized, as at Wembley, and the Prince of Wales again slept under canvas in the Scout camp.

The Jamboree ended with a Farewell March Past to the Chief Scout, the Scouts of all nations, arm in arm in lines of twenty-five, marching with their flags, hats on staves, and cheering wildly. Then the Scouts formed a great wheel—the "Wheel of Friendship"—round Baden-Powell. "Here is the hatchet of war, of enmity, of bad feeling, which I now bury in Arrowe," said Baden-Powell, and drove a hatchet into a barrel of arrows. Then he continued: From all corners of the earth you have journeyed to this great gathering of world fellowship and brotherhood. Today I send you out from Arrowe to all the World, bearing my symbol of peace and fellowship, each one of you my ambassador bearing my message of love and fellowship on the wings of sacrifice and service, to the ends of the earth. From now on, the Scout symbol of Peace is the Golden Arrow. Carry it fast and far, so that all men may know the brotherhood of man.

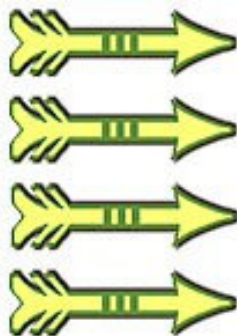

Then B.-P. sent four golden arrows to the four points of the compass, and they were passed from hand to hand through the nations of the world. His final message was then given:

"I want you all to take back to your countries a good account of Great Britain and all the boys you have met here, and the people who have tried to be good to you. Of course, any can see the bad points in people or a country, but a good Scout will look out for the good points in other people. I want you to remember the good points in us and forget the bad ones. Tell your friends in your own countries all the good you can about us, so that we can all think better of one another. Go forth from here as ambassadors of goodwill and friendship. Each one of you Scouts, no matter how young or small, can spread a good word about this country and those you have met here. I can only say now "Good-bye to you. Farewell." . . . Try to carry on your Scout work in the meantime. Try to make yourselves better Scouts than ever. Try to help other boys, especially the poorer boys, to come and be happy, healthy, and helpful citizens like yourselves. And now, farewell, good-bye, and God bless you all."

# DECEMBER 2004 HOLIDAY FOOD FARE

## Gathering Activity

### GOOD GATHERING ACTIVITIES

1. Are age appropriate
2. Keep the boys' interest
3. Are not complicated
4. Are not mandatory
5. Can be terminated at any point
6. Tested at home first!

### RESOURCES

- Roundtable
- Program Helps
- Cub Scout Leaders How-To Book
- Cub Scout Magic
- Scouting Magazine
- Boys' Life Magazine
- Roundtable
- Pow Wow Books
- Den Chief's Handbook
- Children's magazines
- Coloring Books
- Public Library
- Puzzle Books
- School "Fun" sheets
- Other Cub Scout Leader training:
  - Cub Scout Leader Basic
  - Powwow
  - Outdoor Webelos Leader (OWL) Training (NOT just for Webelos Leaders)
- The Internet!



### FUN PAGES

Fun pages can include mazes, color pages, crosswords, word searches, school pages and short answer pages. These are great if you don't have a lot of space in your meeting room, and they generally require only a pencil or colors. They can serve a dual purpose if they touch on one of the topics that will be covered in more detail later on in the meeting. It's actually fun to make some pages yourself!

### SAMPLE GATHERING ACTIVITIES

#### MEMORY TRAY (also known as Kim's Game)

Make up a Memory Tray with 12 simple items spaced out on a tray with a cloth to cover it all. As each scout arrives, give him a piece of paper and a pencil. Then uncover the tray for him (and him alone) for one full minute (be sure to time it). He has four minutes to write down what he can remember was on the tray. Talking is not allowed until ALL scouts have turned in their paper. Spelling is not an issue. Some suggested items: clothespin, pencil, button, fork, dime, key, postage stamp, nail, shoelace, ball, bottle cap, lipstick.

# DECEMBER 2004

## HOLIDAY FOOD FARE

### Gathering Activity

#### JIGSAW PUZZLES

Cut up full-page color pictures from magazines. Have at least one puzzle per scout. As each scout arrives, hand him one to put together. If time permits, let the scouts exchange puzzles.

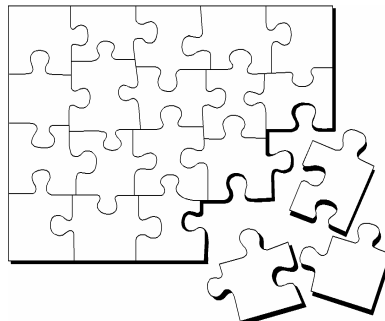

#### HELPS OTHER PEOPLE GAME

As the tigers and their partners arrive, the name of a famous person, organization that "HELPS OTHER PEOPLE" is pinned on the back of each person without them seeing the name (or you can use pictures if available). They must go around the room asking questions of other people to try to guess who they are. They can only ask one person three questions before they have to go to another person. Some ideas for names include:

SUPERMAN	MOTHER THERESA	SALVATION ARMY	BATMAN
RED CROSS	MIGHTY MOUSE	MARTIN LUTHER KING	LASSIE
LONE RANGER	WONDER WOMAN	RUDOLPH	JERRY LEWIS
SANTA	ABRAHAM LINCOLN	WIZARD OF OZ	

#### CHRISTMAS MAP

Make a Christmas map. Find cities with names associated with Christmas. Place names on flag pins and poke in the map. Can you find Christmas Island? There are two, one in the Indian Ocean between Australia and Indonesia and the other just south of Hawaii in the Line Islands.

Here are some others you could look for or see how many more you can add to this list:

North Pole, Alaska	Joseph City, Arizona	Bethlehem, New Hampshire
Noel, Missouri	Snowflake, Arizona	"Carroll", New Hampshire
Santa Claus, Indiana	Mt. Angel, Oregon	"Carroll", Tennessee
Evergreen, Alabama	Nicholas, Kentucky	Bell, Kentucky
Helper, Utah	Holly Green, Arkansas	Snowhill, Maryland
"Holladay", Utah	Berry, Alabama	Merryville, Louisiana
Berryville, Arkansas	Bow, New Hampshire	Star, Idaho
	Bethlem, Pennsylvania	

# DECEMBER 2004 HOLIDAY FOOD FARE

## Opening

### PEACE AND FRIENDSHIP OPENING

Each boy holds a letter. The letters spell PEACE.  
On the back of each piece of posterboard have their lines written.



Sometimes during the holidays  
As the days go rushing by.  
Take time to see the holiday lights  
Mist-halloed against the sky.

Sometime during the holidays  
Breathe deep the holiday smell.  
The bayberry and the piney scents  
What welcome they foretell.

Sometime during the holidays  
When carolers are singing.  
Retell the age-old story.  
For which the bells are ringing.

Sometime during the holidays  
Midst the gaiety and noise.  
Take time to hear the quietness  
Of simple Christmas joys.

Sometime during the holidays  
Remember friends are near.  
And feel the warmth of knowing  
Your friendship's very dear!

### DO UNTO OTHERS

Cub #1: The holidays are a time for Giving!

Cub #2: The holidays are a time for sharing!

Cub #3: The holidays are a time to think of other!

Cub #4: All year we should remember to do a good turn, give good will.

ALL: AND DO UNTO OTHERS!

### THE FOUR GIFTS OPENING

**Cubmaster:** Christmas is a wonderful time to show love to others through giving gifts. It is also a time we can look at the many gifts we have already been given and enjoy each day. I have four gifts wrapped up that represent some of the gifts that each of us receive by living in a free country.

(Four Cub Scouts unwrap the gifts and read, in turn, the statements found inside.)

**C.S.#1:** The gift of freedom--Freedom to worship as we choose and to express ourselves and our ideas without fear.

**C.S.#2:** The gift of beauty--We live in a country full of beauty and wonders. From mountains to plains, from valleys to seas, it is ours to enjoy as we freely travel its width.

**C.S.#3:** The gift of opportunity--We are free to become whatever our ambitions and desires lead us to. Our limits lie only within ourselves.

**C.S.#4:** The gift of pride--We can be proud of a country where we are blessed with freedom and justice. We can be proud each time we see "Old Glory," our country's flag, unfurled. We can be proud to be an American.

**Cubmaster:** With these gifts in mind, will you please stand and pledge your allegiance to our country and our flag.



# DECEMBER 2004

## HOLIDAY FOOD FARE

### OPENING – With Apologies To Charles Dickens

York Adams Area Council

**Reader:** This is a special time of year for people all around the world. It is a time of Joy and Light, of Hope and Peace, and of the comforts of Home, Family, and Tradition. It is a time of Spirit in all things, and although there are many different types of Spirit and Spirits among us, tonight we are going to be visited by four of them.

**Spirit Of Christmas:** "I am the Spirit of Christmas" (Lights Advent candles, using appropriate prayer(s) and a brief statement as to what the candles and the holiday represent.)

**Spirit Of Chanukah:** "I am the Spirit of Chanukah" (Lights the Chanukah candles using the appropriate prayer(s) and a brief statement as to what the candles and the holiday represent.)

**Spirit Of Kwanzaa:** "I am the Spirit of Kwanzaa" (Lights the Kwanzaa candles and gives a brief statement as to what the candles and the holiday represent.)

**Spirit Of Scouting:** "I am the Spirit of Scouting, and here I light the twelve candles which the twelve points of the Scout Law, and three candles which represent the three points of the Scout Oath. I will also light one additional candle of the purest white, which represents not only the Spirit of Scouting, but also all the other Spirits of Goodness which exist throughout this old world of ours no matter what they may be called. Now, I call upon my Fellow Spirits, and all of you here in this room, to join with me in reciting the Cub Scout Promise.

**All:** (Cub Scout Promise)

**Reader:** Thank you all. Please be seated.

**All Spirits:** "Happy Holidays!"

### I WILL USE...

Have a Cub Scout read the narrative, or pass out cards so the entire audience can read this pledge in unison, or have 5 or 6 Cub Scouts repeat the lines from cards, while other Cubs hold a poster with the words \* This is my country\* printed on it.

1ST CUB - I will use my eyes to see the beauty of this land.

2ND CUB - I will use my ears to hear it's sounds.

3RD CUB - I will use my mind to think what I can do to make it more beautiful.

4TH CUB - I will use my hands to serve it and care for it.

5TH CUB - And with my heart, I will honor it.

Will everyone please stand for the Pledge.

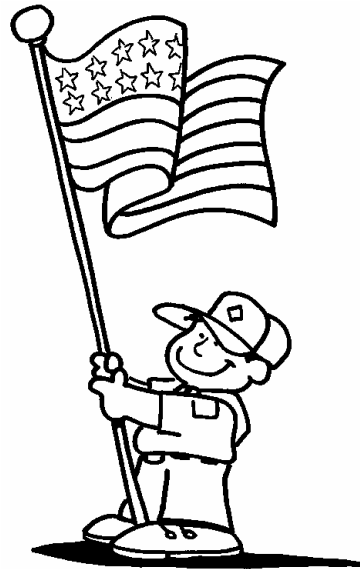

# DECEMBER 2004 HOLIDAY FOOD FARE

## Den Activity

### SERVICE PROJECTS FOR DEN & PACK

Along the rail of Scouting, we promise...to “HELP OTHER PEOPLE”, and that, “THE CUB SCOUT GIVES GOODWILL”. It is important for a Cub Scout to gain an understanding and experience the satisfaction in helping those less fortunate than himself.

Do the Cub Scouts really know the meaning of:

*“ I \_\_\_\_\_, promise to do my best  
To do my duty to God and my country,  
To help other people  
To obey the Law of the Pack.”*

“To help other people” not only is said each time the Cub Scout Promise is recited, but should also be lived daily by all Scouts.

By organizing home and community service projects, you will be giving your Scouts the opportunity to “reach out” into a wider community, making them feel a part of their community, and to recognize the importance of good citizenship. Your pack could select one or more service projects to work on throughout the year. Thanksgiving and Christmas are common service project times of the year, but the need exists year round. Collect food and clothing in your neighborhood to donate to a shelter for the homeless; families need warm weather clothing, too. Perhaps your pack could adopt a family for a year; help them with their food, clothing needs, and presents during the holidays.

Packs can arrange to do on going projects for which responsibilities can be rotated among the dens. Volunteer to pick up trash and litter once a month around your neighborhood or church; each den takes a turn. Organizations which serve food to the homeless on a regular basis may need volunteers as servers, or for bussing tables; pick one day a month with each den taking a month to serve.

Your den could provide entertainment and or companionship to the elderly in the nursing homes; wear costumes and present a skit or sing a few songs. Give a puppet show to boys and girls at the children’s hospital. Collect magazines and donate them to nursing homes or hospitals; gather games, books, and puzzles to take to a day care center. Rake leaves for an elderly couple in your neighborhood.

One great way to encourage the Scouts to “Do a good turn daily” is for you to set a good example at den and pack meetings through your words and deed. When the boys see the adults around them picking up the trash after refreshments at the pack meeting, or stopping to help someone, they’ll feel the need to repeat your lead.

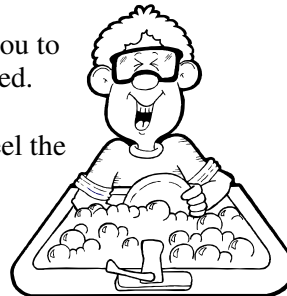

Before beginning a service project two things are essential.

- ◆ Consider the boy’s age.
- ◆ Regardless of age, how mature are they?

# DECEMBER 2004 HOLIDAY FOOD FARE

## Den Activity

### SERVICE PROJECTS FOR DEN & PACK Continued



You must have sufficient leadership, two deep obviously. Decide when you will be doing your service project; in the den meeting or on a weekend. Requiring every Scout to get to the location on their own usually means a parent has to come and stay giving you plenty of adults to help.

When you are ready to pick out a project, don't do it alone.

Get the Scouts involved in decision making. Give them a few ideas and let them choose democratically.

Make contact with organizations and **GET PERMISSION.**

Set a date in advance and inform parents.

For safety, if parent is not present at service project, get a signed permission slip.

If service project is not for the chartered organization you are with and you must travel, **GET A TOUR PERMIT.**

Follow through with your plans.

Limit the awards or recognition to a verbal thank you or appreciation, or at most, write it up in the newsletter. Credit can be given in their Scout handbooks. Remember keep it simple. Boys should learn that the true reward is the feeling you get when you help.

Service, best exemplified by the daily Good Turn, has long been a tradition in Scouting. Good citizenship is best taught by service in action. To get the most Cub Scouting has to offer, boys should have opportunities to take part in den and pack service projects. This is one of the best ways to show boys that helping other people is not only beneficial to others, but is fun and rewarding for themselves. They will experience a warm feeling that comes from giving service to others. Below are some suggestions for service projects that Cub Scouts will enjoy:

Organize a spring cleanup.

Assist a person with special needs or an elderly person in the neighborhood.  
Rake they yard, wash widows and screens, run errands.

Conduct a paint and cleanup project at the building and on the grounds of the chartered organization.

Paint oil drums or heavy five drums with metal lids for use as litter containers.

Adopt a stream. Clean debris and litter from a section of a nearby stream.

Send a care package to American troops.

# DECEMBER 2004 HOLIDAY FOOD FARE

## Den Activity

### SERVICE PROJECT IDEAS Continued

- ◆ Man a water station at a fun run.
- ◆ Help pack Red Cross Friendship boxes.
- ◆ Clean up the telephone poles of old signs.
- ◆ Donate a tree for Arbor Day to a park.
- ◆ Adopt a police or fire station and send Thank you's and goodies.
- ◆ Do a fire prevention program for a day care center.

These are only a few ideas for service projects. You'll find many more in Cub Scout and Webelos Scout Program Helps and other Scouting literature.

Cub Scouts like being helpful. Scouting has always emphasized the Good Turn, and boys are never too young to start doing things for others. Scouting can offer one antidote to the many messages focusing on self-interest that boys receive from the media and the culture in general.

There are many ways to be helpful. Some service projects are "behind the scenes," like cleaning up the church parking lot or making gifts for people the boys will never see. Other services are provided directly to individuals. Both forms of service are useful and should be encouraged.

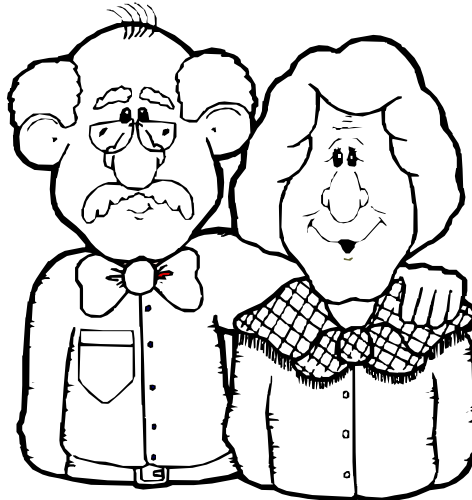

# DECEMBER 2004 HOLIDAY FOOD FARE

## Craft

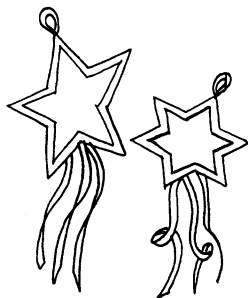

### SHOOTING STARS OR HANUKKAH STAR

Draw a five-point star or Star of David about 3 inches across on cardboard for pattern (enlarge to desired size). Then draw a slightly smaller star pattern. Use two different colors of bright colored felt, cut a star out of each. Use 2 matching ribbons colors. Cut three 8-inch strand of ribbon from each color. Make sure all ends are even and then staple across the top several times to hold them together. Lay the large star on the table and place the stapled ribbons together in the center of the star. Put glue on the back of the smaller star and turn it over and center it on the larger star, securing the ribbon strands. When the glue has dried, carefully poke a small hole in the top of the star and thread a short piece of ribbon through it for a hanging loop. You may add glitter,

sequins, beads, or write Shalom or Peace on star with fabric paints.

### PENGUIN PINS or TIESLIDE

*Need:*

*Craft sticks*

*Black, white and orange acrylic paint*

*3/8 " red felt*

*Tiny white pom poms*

*Tacky glue; glue gun*

*Sunflower seeds in shell*

*Paintbrush*

*1" long x 1/4" wide square of knit rib fabric*

*Pinback or chenille pipe cleaner*

*toothpick*



### DIRECTIONS:

Paint seed orange and craft stick black.

*When dry*

Paint white oval on stick, from top to 1 inch above bottom.

Glue seed nose 1 inch below top of craft stick.

Paint eyes 1/4" below top and buttons using a toothpick.

Glue felt scarf around neck; fringe edges.

Hat: Glue 1/4" at 1-inch edges of rib fabric together

Gather and glue one end closed; turn. Fold under 1/8" at lower edge.

Glue onto stick.

Glue pom-pom on top.

Hot glue pinback or chenille pipe cleaner to back of craft stick.

### COLLECTOR'S PLATE ORNAMENT

Cut out pictures of collector's plates found in many magazines. Glue these to: paper plate, cardboard, small lightweight wood circle, or plastic play plates cut to the size of the picture. Glue on a silver or gold looped string or ribbon for hanging.

# DECEMBER 2004 HOLIDAY FOOD FARE

## Craft

### DREIDEL PHOTO MAGNET

- ◆ Trace dreidel patterns on two colors of craft foam (enlarge to desired size).
- ◆ Cut out shapes. (Using pinking shears to cut one of the shapes)
- ◆ Cut circle from center of small shape
- ◆ Glue photo (approx. 2" x 2") on back of small dreidel foam shape so picture shows through round opening.
- ◆ Center and glue small dreidel shape on large dreidel shape.
- ◆ Decorate as desired with bow, hole punched foam circles. Glitter, or greeting written with marker.
- ◆ Press magnetic strip on back of dreidel.

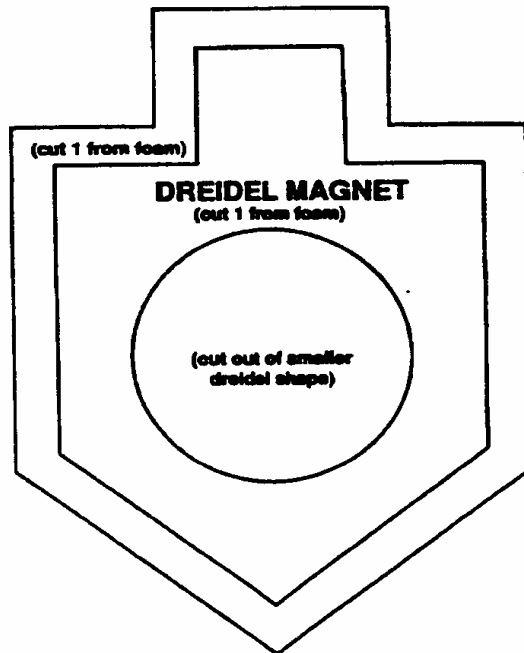

### ICE CREAM CONE ORNAMNET

Glue a 3 - 4" diameter red sating ball ornament to a sugar cone. Add cotton around juncture between cone and ball and on top of ball. Use hanger from satin ball extending through cotton fluff on top to hang from tree. Be sure and spray cones with a spray shellac to prevent ants or other bugs from destroying the cone.



### KITCHEN SINK POT

Decorate a 4 - 6" diameter clay pot using magic markers, or cut out scrap fabric using pinking shears. Paint the piece on by using a watery Elmer's glue mix and a paintbrush. Be sure the bottom has a hole for draining. Keep kitchen scrubbers in it.

### SNOW COVERED PINECONES

Place glue on ends of individual cone leaves and sprinkle glitter on. Or you can use glitter fabric paint glued directly to ends of cones leaves to give the effect of fallen snow.

# DECEMBER 2004 HOLIDAY FOOD FARE

## Craft



### PASTA WREATH ORNAMENTS

**Materials needed:** *Tagboard or cardboard cut out into a wreath shape*  
*Glue*  
*Various shapes of uncooked pasta*  
*Spray paint*  
*Ribbon*  
*Hot glue gun*

### DIRECTIONS:

1. Glue the various shapes of pasta all over the circular wreath pattern.
2. Use a hole punch to make a hole at the top of the ornament.
3. Once the pasta has dried thoroughly, spray the wreath with spray paint.
4. Use a hot glue gun to attach a ribbon hanger to the wreath.

### CINNAMON STICK SANTA PIN or TIESLIDE

#### **Materials needed:**

*Cinnamon stick* *Red acrylic paint*  
*White iridescent craft paint* *Cotton*  
*Pin backing or chenille pipe cleaner* *Hot glue gun*  
*Small paint brush* *Glitter glue (optional)*  
*Fine tipped permanent black marker*



### DIRECTIONS:

- ◆ Paint the cinnamon stick with red acrylic paint.
- ◆ Paint a face with white iridescent craft paint.
- ◆ Use fabric paint to add a hat brim, mustache, and beard to Santa's face. You might also use cotton.
- ◆ Use a fine tipped black marker to add a face and belt to Santa. Tiny black buttons might also be used.
- ◆ Embellish the hat and Santa suit with glitter glue if desired.
- ◆ Attached a pin back to the back of Santa with a hot glue gun.

### PLACEMATS AND COASTERS

You can use existing artwork or have your boy's design something special.

For placemats, have the boy's draw, paint or color a picture on a large piece of paper, then laminate it or cover it with clear contact paper.

For coasters, you might have the boys trace his handprint on colored paper and laminate.

Don't forget to sign and date the back!

# DECEMBER 2004

## HOLIDAY FOOD FARE

### Craft

If you are having a Kwanzaa celebration in your home, make a list of all the people you wish to invite. Look through magazines for examples of African fabric and designs (Corel Gallery Magic clipart has a large selection as well) You can follow these designs on your invitations and other decorations. Look around the house for a special cup that you can use for the unity cup. Start gathering dried vegetables and fruits to make up the mazao. These fruits and vegetables represent the crops of harvest, or the many good things in our lives. Make Kwanzaa decorations; the colors of Kwanzaa are red, black and green.

Kwanzaa gifts are not meant to cost a lot of money. Instead, the gifts are meant to celebrate the spirit of kuumba, or creativity.

#### **KWANZAA MAT**

*You will need:*

*Ruler*

*Scissors*

*Glue or clear tape*

*Black, red and green construction*

*paper*

Measure and cut out a piece of black construction paper eight inches wide and ten inches long. Cut seven lines in the paper, leaving a one-inch border all the way around the mat. See illustration.

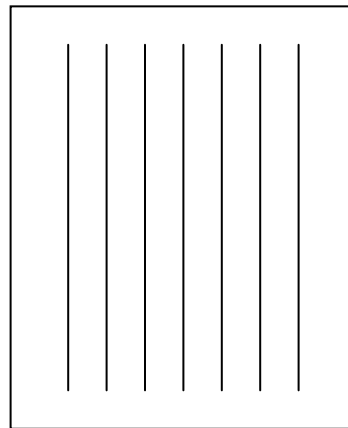

Cut four red and four green strips of construction paper one inch wide and eight inches long.

Weave a red strip and then a green strip alternately, going over and under the black mat frame. Keep the black border. Secure the ends of the strips with glue or clear tape

Place your mat on the table and decorate with corn and other harvest foods.

#### **OTHER KWANZAA ACTIVITIES**

1. Take out the old photograph album and tell your children about their ancestors.
2. Show some movies about your country and her people.
3. Take the children to the library and have an "Africa" scavenger hunt for information about Africa.
4. Create a family tree.
5. Play the game OWARE.



# DECEMBER 2004

## HOLIDAY FOOD FARE

### Craft

#### CHOCOLATE MELTING SPOONS

Yummy!

Simply dip colored plastic spoons in melted dark, milk or white chocolate (or candy coating) and top with multicolored or glittery sprinkles. Wrap in clear or colored cellophane, tied with ribbon. For a special addition to this yummy gift, glue a photo of the boys onto a square of construction paper & make a gift tag.

#### POSTAL PAPERWEIGHT

Your boys will have fun sorting through the mail to collect interesting canceled stamps. When they've collected several, soak the stamps in warm water until they separate from their envelopes. Let the stamps dry. Then glue them onto a small rock. Brush on "Modge Podge", white glue or a clear finishing gloss.

#### PERSONALIZED ORNAMENTS

Encourage creativity by having kids paint plain glass or plastic ball ornaments with fabric paint. The possibilities are endless! Snowmen, Stars, Snowflakes...Many of the plastic balls can be easily filled with curling ribbon to add color. A special holiday message can also be inscribed.

#### SNOWMAN PIN

A gift that is sure to please. You'll need two white buttons, each with two holes. One button should be larger than the other. Glue the buttons to the back of a jewelry pin. The smaller button with the holes positioned horizontally for eyes and the larger button with the holes vertically for buttons. Cut out a hat from black felt or fun foam and glue to the head. Tie a ribbon around the neck for a scarf. Glue pin on back. Great gift for Mom!

#### DECORATIVE SOAP BARS

*Need:*

*Bar of soap (regular or glycerin)*

*Acrylic paints*

*Paintbrushes*

*Aluminum Coffee can*

*Large pot*

*Canning wax or a white candle*

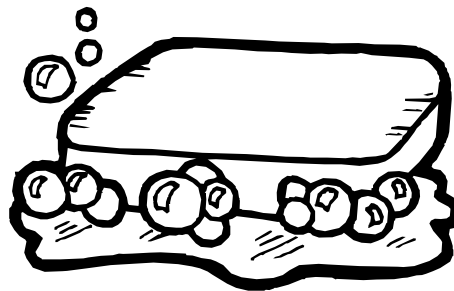

#### DIRECTIONS:

Have the boys paint designs on the soap with the acrylics, while you create a double boiler. Put the coffee can in a pot half-filled with water. Drop in wax and melt it over low heat. Then use a disposable paintbrush to cover the design on top of the soap. Let the wax dry. The protective coating will allow the soap to be used without washing away the picture.

# DECEMBER 2004 HOLIDAY FOOD FARE

## Craft

### STAINED GLASS CARDS

#### *Materials needed:*

*Construction or other paper*

*Scissors*

*Pencil*

*Hole puncher*

*Tissue paper (different colors)*

*Glue or tape*

*Ribbon or yarn*

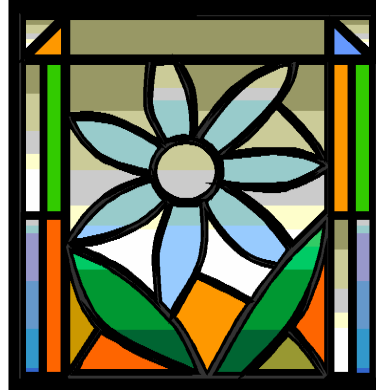

#### **What to do:**

**Snowflake:** Draw a circle and cut it out. Fold it in half three times. Snip little pieces from the sides. Open it up and you have a snowflake.

**Tree:** Cut a piece of paper in half. Draw an outline of a pine tree and cut it out. Punch a hole at the top of the tree. Punch other holes all over the tree.

For both the snowflake and the tree, cut up small pieces of different colored tissue paper and place them over everything but the top hole. Glue or tape in place. Put a piece of ribbon or yarn through the top hole and tie so that it forms a loop. Write your greeting and send it off to a friend or relative to hang in a sunny window.

Variation: See what other shapes (star, drum, and dreidel) your child can turn into stained glass!

### GIANT REINDEER CARD

#### *Materials needed:*

*White paper (10" x 12" or larger)*

*Tempura paint (brown for the body and other colors for the antlers)*

*A tray for each color*

*Sponge*

*Ready made eyes (small)*

*Pom-poms*

#### **What to do:**

Fill a tray with brown paint. Have your child either put the bottom of one foot in the paint or sponge the paint onto the bottom of the foot. Place the painted foot on the white paper so that the heel is centered near the bottom of the page. This forms the head of the reindeer.

Paint the bottom of your child's left hand with a different color. Place the painted hand at an angle and touching the toe on the left side of the footprint. This forms one antler.

Repeat with the right hand to make the other antler.

When the paint is dry, have your child glue on two eyes and a pom-pom for the nose.

# DECEMBER 2004 HOLIDAY FOOD FARE

## Songs

### DO YOUR GOOD TURN

*Tune: Clementine*

Do your good turn, help a neighbor,  
Spread friendship and joy anew.  
You're a Cub Scout! Wow, a Cub Scout!  
Doing good turns is what we do!

Clean the school yard, pick up litter,  
And do errands, yes, we do!  
Help our friends to do their homework,  
Being helpful, that's not new.

Keep our parks clean, help our trees grow,  
Make sure everything looks like new.  
Be a Cub Scout, Wow a Cub Scout!  
Doing good turns, that's what we do!

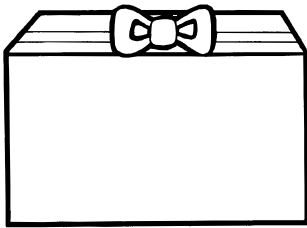

### HOLIDAY TIME

*Tune: Jingle Bells*

Holidays are a time  
When there's something in the air  
More than bells that chime  
More than songs to share.  
Something gay and bright,  
More than lights a glow,  
You sense it morning,  
Noon and night,  
Wherever you may go.

### CHORUS

Holiday time, holiday time,  
Every Jack and Jill,  
Knows what fun it is to feel  
All a tingly with goodwill

Holiday time, holiday time,  
Though the air is chilled,  
Everyone is tingly now,  
With a feeling of goodwill!



### GOODWILL SONG

*Tune: Jingle Bells*

Giving time, sharing time, fun for everyone.  
Scouters know that Holidays are  
The time for deeds well done.

Giving time, sharing time, let us all take part.  
Join with Cub Scouts everywhere,  
Give gifts from the heart.



# DECEMBER 2004 HOLIDAY FOOD FARE

## Songs

### A HANUKKAH SONG

Greater St. Louis Area Council

*Tune: Three Blind Mice*

Eight bright lights, eight bright lights,  
See how they glow, see how they glow,  
They call to mind the Maccabees,  
The struggle for our liberties,  
The glory of their victories,  
Eight bright lights.

Menorah Light, menorah Bright.  
See how it shines, see how it shines.  
The candles shine with a light so bright,  
See how it brightens the darkest night,  
Have you ever seen such a sight in your life,  
Menorah Bright!

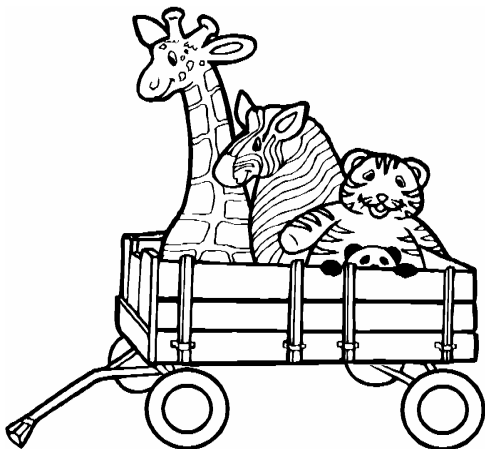
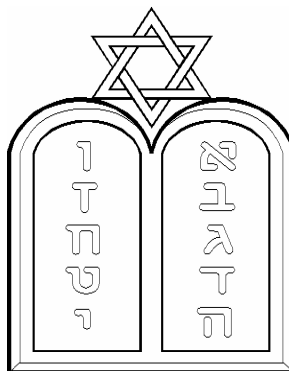

### HOLIDAY GREETINGS

*Tune: Are you Sleeping*

Christmas greetings,  
Kwanzaa greeting,  
Hanukkah, it's that time,  
Holidays are super,  
Present super duper  
Candles glow, candles glow.

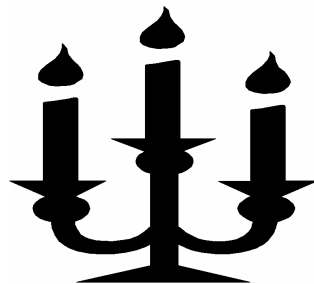

### CHRISTMAS SONG

*Tune: Rudolph the Red Nose Reindeer*

Here's to the Cubs in our den,  
As they follow, help and give;  
All of the boys in our den  
Know just how a Cub should live.

Now it's time for Christmas,  
We've been very helpful boys,  
We've gathered lots of old things,  
Fixed them up like brand new toys.

Saved our pennies every meeting,  
Bought a lovely Christmas tree,  
Trimmed it up to take to our  
Den adopted family.

Bright and early Christmas morn',  
When they see our shiny toys,  
We'll be happy that we shared  
Our Christmas joy with other boys.

# DECEMBER 2004

## HOLIDAY FOOD FARE

### A Scout's Christmas

(Tune: Jingle Bells)

Dashing through the den,  
With a rope held by each end,  
Tying a bowline knot  
Then showing what I've got.

Whittling with my knife  
On a practice Dial soap bar.  
I can hardly wait,  
Scout camp can't be far.

Bait a hook,  
Learn to cook,  
Bike ro-de-os.  
Neckerchief slides,  
Canned food drives,  
Learning to take photos.

Pancake mix,  
Carving sticks,  
Keeps us on the run.  
Our families  
Make all these  
Memories so much fun.

Dashing through the camp,  
Putting up the tents,  
Popping all the corn,  
Blowing that morning horn.

Of scout camp we all dream  
We'll soon be old enough  
Tigers, Bobcats, Wolves, and Bears  
We're made of real tough stuff!

Half-hitch knots,  
Setting up cots,  
Playing fun new games.  
Hammers and nails,  
Compass and trails,  
Arrow points are the thing.

Santa's coming,  
We've been good,  
As good as we can be...  
Load our stocking  
With a pocket knife,  
Boy Scouts we want to be!

### Twelve Scouting Days of Christmas

(Tune: 12 Days of Christmas)

On the first day of Scouting, Akela gave to me.  
A Den Leader swinging from a tree!

On the second day of Scouting, Akela gave to me  
Two Screaming Bobcats,  
And a Den Leader swinging from a tree!

OK, you should have the idea by now.  
Here's the rest of these silly verses:

Third Day - Three Skinny Wolves

Fourth Day - Four Hungry Bears

Fifth Day - Five We be lost

Sixth Day - Six Arrow points

Seventh Day - Seven Silly Den Chiefs

Eighth Day - Eight Shouting Scouts

Ninth Day - Nine Warring Eagles

Tenth Day - Ten Derby Cars

Eleventh Day - Eleven Funny Den Skits

Twelfth Day - Twelve Wacky Cheers

### He'll Be Driving 8 Brown Reindeer When He Comes

(Tune: She'll Be Coming 'Round the Mountain)

He'll be driving 8 brown reindeer when he comes,  
He'll be driving 8 brown reindeer when he comes,  
He'll be driving 8 brown reindeer, driving 8 brown  
reindeer,  
He'll be driving 8 brown reindeer when he comes.

(Other verses)

He'll be coming down the chimney when he comes.  
He'll be dressed up in a red suit when he comes.  
We'll all peek to see him when he comes.  
We'll give him milk and cookies when he comes.

### S-A-N-T-A

(Tune: BINGO)

Every Cub Scout has a friend  
And Santa is his name, sir  
S-A-N-T-A,  
S-A-N-T-A  
S-A-N-T-A  
And Santa is his name.

Sing song through six times, the first time just spelling  
out the name S A N T A; second time, spell out first  
four letters and clap the A etc.

# DECEMBER 2004

## HOLIDAY FOOD FARE

### I'm Playing In The Snow

(Tune: I'm Singing in the Rain)

I'm playing in the snow.  
I'm playing in the snow.  
What a glorious feeling  
It's snowing again.  
Making snowman tonight  
For the whole world to see  
I'm happy just playing  
In the snow.

### Tommy, the Cub Scout

(Tune: Frosty the Snowman)

Tommy, the Cub Scout  
Was a very happy boy  
With a uniform of blue and gold  
And a den that gave him joy.

Tommy, the Cub Scout  
Earned his badges one by one.  
He did his best and met the test.  
A good citizen he's become.

He helps out other people when  
He sees they need a lot.  
He does his chores around the house  
And feeds his dog (named Spot).

Tommy, the Cub Scout  
Does his duty willingly.  
Someday he'll join a Boy Scout Troop  
And a fine man he will be.

### DO YOU KNOW THE NAMES OF THE EIGHT REINDEER?

Now Dasher! Now Dancer! Now Prancer and Vixen!  
On, Comet! On Cupid! On Donner and Blitzen!  
To the top of the porch! To the top of the wall!  
Now, dash away, dash away, dash away, all!  
-From A Visit From St. Nicholas, by Clement C. Moore

(Rudolph was a later addition...)



# DECEMBER 2004 HOLIDAY FOOD FARE

## Skits

### THE GOLDEN RULE

*Personnel: 8 boys*

*Equipment: Posterboard*

*Preparation: Have the boys draw a picture of what he feels the "The Golden Rule" stands for. On the back of the poster print The Golden Rule that he has drawn about and have each boy read it.*

### Christian (Matthew 7:12)

All things whatsoever ye would that men should do to you, do ye even so to them: for this is the law and the prophets.

### Buddhist (Udana-Varga 5:18)

Hurt not others in ways that you yourself find hurtful.

### Taoist (T'ai Shang Kan Ying P'ien)

Regard your neighbor's gain as your own gain and your neighbors loss as your own loss.

### Jewish (Talmud, Shabbat 31a)

What is hateful to you, do not to your fellow man. That is the entire Law; all the rest is commentary.

### Brahman (Mahabharata 5: 1517)

This is the sum of duty: Do not unto others, which would cause you pain if done to you.

### Confucian (Analects 15:23)

Surely it is the maxim of loving-kindness: Do not unto others what you would not have done unto you.

### Zoroastrian (Dadistan-I-dinik 94:5)

That nature alone is good which refrains from doing unto another whatsoever is not good for itself.

### Islamic (Sunnah)

No one of you is a believer until he desires for his brother that which he desires for himself.

### ALL:

We should all try to bring to this holiday season peace and joy for everyone one and treat each other the same.

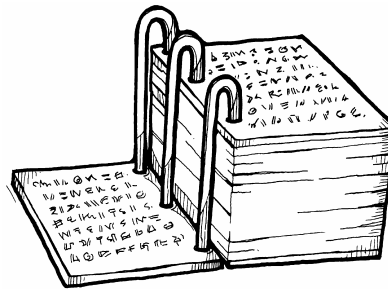

# DECEMBER 2004 HOLIDAY FOOD FARE

## Skits

### DO YOUR BEST

#### CHARACTERS:

*CHARLIE BROWN, LINUS, CUB SCOUTS (As many as 8 and as few as 3.)*

CUB 1: This is a great time of year!

CUB 2: It sure is! Snow ... Santa Claus ... presents ... its all just great.

CUB 3: Well, here comes Charlie Brown and Linus.

3 CUBS: Hi Linus. Hi Charlie Brown.

CUB 4: What's the matter Charlie Brown?

CHARLIE: I was just thinking. All I will probably get for Christmas is rocks! That's all I got at Halloween.

CUB 5: That's not all there is at Christmas.

CUB 6: There's snow.

CHARLIE: That means Lucy will throw snowballs at me!

CUB 7: How about Christmas trees?

CHARLIE: Snoopy knocked mine down!

CUB 8: There's also mistletoe and bells and Christmas carols . . .

CHARLIE: Bells hurt my ears, only my mother wants to kiss me and I can't sing. If that's all Christmas is about, I guess I don't like it much. I wonder if that's all there really is?

LINUS: No, Charlie Brown, there is much more. Let me tell you what Christmas is all about.  
"... And there were in the same country shepherds abiding in the field, keeping watch over their flock by night. And lo, the angel of the Lord came upon them, and the glory of the Lord shone round about them; and they were so afraid. And the angel said unto them, 'Fear not, for behold, I bring you good tidings of great joy, which shall be to all people.  
For unto you is born this day in the city of David, a Savior, which is Christ the Lord. And this shall be a sign unto you. Ye shall find the babe wrapped in swaddling clothes, lying in a manger.'  
And suddenly there was with the angel a multitude of the Heavenly Host praising God and saying: 'Glory to God in the highest, and on earth peace, good will toward men.' And that's what Christmas is all about, Charlie Brown.

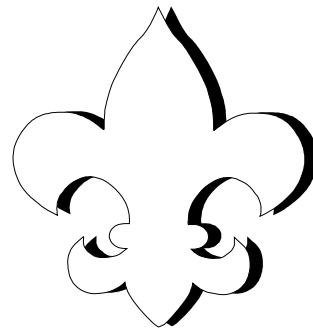

Submitted by

Otetiana Council

Pow Wow 1981



# DECEMBER 2004 HOLIDAY FOOD FARE

## Advancement Ceremony

### THE SPIRIT OF SCOUTING

Author: Unknown Scouter

### PERSONNEL

Arrow of Light Award candidates and their parents,  
Webelos den leader (*or committee member in charge  
of this pack advancement ceremony*).

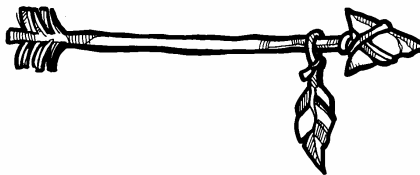

### EQUIPMENT

Ceremonial board, about 18" square, with four candles: blue - spirit of Cub Scouting, white - spirit of Scouting, yellow - Arrow of Light rank, green - Boy Scout; Arrow of Light Awards and certificates; safety pins.

### ARRANGEMENT

At the opening of the ceremony, only the white candle is lighted. The white candle is used to light the blue and yellow candles as the ceremony progresses.

**Den Leader:** Will the following Webelos Scouts come forward to receive the Arrow of Light Award. Please bring your parents with you. (*They come forward as names are called.*) You Webelos Scouts have fulfilled all the requirements for the Arrow of Light Award, the highest rank in Cub Scouting. You have also visited a Boy Scout troop and talked with the Scoutmaster. Before you is a blue candle that represents the spirit of Cub Scouting - that spirit of giving goodwill and doing your best. (*Lights blue candle.*) This white candle represents the spirit of Scouting. Do you promise to fulfill the Cub Scout Promise and the Cub Scout motto, Do Your Best, when you receive the Scout badge?

**Webelos Scouts:** We do.

**Cubmaster:** Webelos Scouts have faithfully promised always to keep alive the spirit of Cub Scouting. As their parents, do you also promise to continue to help your boy in his Scouting adventures?

**Parents:** We do.

**Den Leader:** I now use the flame of the spirit of Scouting to light the yellow candle representing the Arrow of Light Award. (*Lights yellow candle.*) Remember that the spirit of Cub Scouting and Boy Scouting are one and the same. The spirit of the entire Scouting movement is one of service, high ideals, and fellowship.

To each of you parents I present the Arrow of Light Award and ask that you present it to your son.

This award is worn on the Webelos Scout uniform, centered on the flap of the left shirt pocket, and on the Boy Scout uniform later. (*Presents certificates, awards, and safety pins, and instructs parents in pinning badges on shirts.*) It is a great honor for me to greet you who have earned the Arrow of Light Award. (*Gives Cub Scout handshake.*) Notice that we are leaving unlighted the green candle representing a Boy Scout. This is to remind you Webelos Scouts of something yet to be enjoyed, a grand adventure that will open to each of you upon graduation from the pack. Good luck and success to you and your family in your future Scouting career.

# DECEMBER 2004 HOLIDAY FOOD FARE

## Advancement Ceremony

### T'WAS THE NIGHT OF THE PACK MEETING

York Adams Area Council

'Twas the night of the Pack meeting and all through the place. Not a boy was stirring, anticipation on each face.

It was time for Advancements and they all turned an ear, so when their name was called, they would hear it loud and clear. The Cubmaster was checking his list, not once but twice to see which boys had worked hard and earned awards this night.

First come the Bobcats, all new to the Pack Akela is ready with the guidance and experience they lack. Come up our new Cubs, you're our Bobcats tonight Your final step as a Bobcat is to do a good deed, and you must do it right.  
(Present the Bobcat badges)

Second are the Wolves, experienced that's true But there is still much to learn, Akela's not through. Come up all our Wolf Cubs, you are wolves to be praised Achievements and electives you've done, so with Wolf badge and arrow points, in rank you are raised (Present the Wolf badges and arrow points.)

Third are the Bears, most experienced so far, Akela's teachings they have heeded, they're way above par. Come up our Bear Cubs, your work and learning is applauded For completing achievements and electives, tonight you're awarded (Present Bear badges and arrow points.)

Last are the Webelos, but not least to be sure Akela's lessons they've learned, now Boy Scouts is their lure. Come up all our Webelos, your activities are harder, your accomplishments you wear proudly on your shoulder (Present Webelos activity pins)

### THE LIGHT OF CHRISTMAS

by Edward A. Haluska

#### *People required:*

*Cubmaster, Santa Claus*

#### *Props:*

*Tall candle and a candleholder for it,  
Individual candles with drip guards for each  
boy,  
Matches to light candle, Clear punch bowl,  
Red punch, Small paper cups, Ladle, Dry ice,  
Santa Claus suit*



#### Hints:

1) Most Cubs gulp down their punch. However, because of the dry ice, an occasional Cub will be convinced you are trying to poison him. Therefore, use small cups and don't even fill them very full.

2) The dry ice that is dumped into the punch should be in one or two large lumps. That way you won't ladle any small chips of dry ice into the cups being used to serve the boys. As a double check, after you have ladled punch into the cup, check to see if it is bubbling with dry ice. If it is, pour it back into the bowl and try again.

# DECEMBER 2004 HOLIDAY FOOD FARE

## Advancement Ceremony

### THE LIGHT OF CHRISTMAS Continued

3) To find a source of dry ice, look in the yellow pages under "ice." Three pounds of dry ice bought in the afternoon and wrapped in newspaper will be more than enough to last through until an evening pack meeting.

4) If the candleholder for the tall candle will fit in the bottom of the punch bowl and the candleholder can be cleaned well enough, place the tall candle in the middle of the punch bowl for added visual effect.

5) The easiest way to attach the badges to the boys is to have the badge stapled to the small cardboard card it comes with. Make a small slit in the cardboard so that the card may be slipped over the button on the pocket of the shirt.

6) Dim the lighting at the beginning of the ceremony for better atmosphere and so the candles will show up better.

Cubmaster: Tonight, during the Christmas Season, we are gathered here as a pack to recognize those cubs among us who have earned a new rank. But as this is the Christmas season, let us begin this ceremony with a reading from a very special book, the book that tells us why Christmas is so important to all Cub Scouts who do their duty to God.

(Read this passage with the majesty it deserves.)

Now there were in the same country shepherds living out in the fields, keeping watch over their flock by night. And behold, an angel of the Lord stood before them, and the glory of the Lord shone around them, and they were greatly afraid. Then the angel said to them, "Do not be afraid, for behold, I bring you tidings of great joy which will be to all people. For there is born to you this day in the city of David, a Savior who is Christ the Lord. And this will be the sign to you: You will find a Babe wrapped in swaddling cloths, lying in a manger." And suddenly there was with the angel a multitude of the heavenly hosts praising God and saying "Glory to God in the highest, and on earth, peace, goodwill to men!" "And on earth, peace, goodwill to men." Words of hope that have come down to us from a wondrous time long ago. Words that still make our hearts echo back love. So in that spirit let us begin. Parents, bring forward these Cub Scouts. (Cubmaster calls out the names of the all boys who are advancing in rank. Parents and boys come forward and face the rest of the pack.)

Cubmaster: This is the Christmas season. We celebrate Christmas as the birthday of Jesus. As part of our duty to God, to show that Jesus is still the Light of Christmas, we will light this candle. (Cubmaster lights the tall candle.)

Cubmaster: All the darkness in the world cannot stand against the light of one small candle. Through the power of the Cub Scout Promise, our cubs share the Light of Christmas. Therefore, I want each of you boys to come forward one at a time and light your candle from the Christmas candle. (If you have boys who will be getting their Tiger pin, ask...)

Cubmaster: Our new boys who want to be Tigers have studied the Tiger promise. Are you boys ready to make that promise now to yourselves, your parents, and the pack?

(Cubmaster shakes head in yes motion. Boys should also shake their heads yes.)

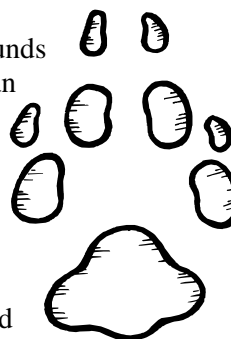

# DECEMBER 2004 HOLIDAY FOOD FARE

## Advancement Ceremony

### THE LIGHT OF CHRISTMAS Continued

Cubmaster: Then hold your candle in your left hand, make the Cub Scout sign with your right hand, and repeat after me.

I promise to love God, my family and my country, and to learn about the world.

(If you have boys who will be getting their Bobcat badge, ask...)

Cubmaster: Our new cubs who want to be Bobcats have studied the Cub Scout promise. Are you boys ready to make that promise now to yourselves, your parents, and the pack?

(Cubmaster shakes head in yes motion. Boys should also shake their heads yes.)

(If you have boys who will be getting their Wolf, Bear, or Webelos badge, ask...)

Cubmaster: As part of being a Cub Scout, you boys who want to advance in rank have followed the Cub Scout Promise. Are you boys ready to renew that promise now to yourselves, your parents, and the pack? (Cubmaster shakes head in yes motion. Boys should also shake their heads yes.)

Cubmaster: After tonight, you will carry the light of the Christmas candle inside of your heart. The light you will carry will come from the five things you are about to promise. You will promise to:

1. Do you best
2. Do your duty to God
3. Do your duty to your country
4. Help other people
5. And obey the Law of the Pack.

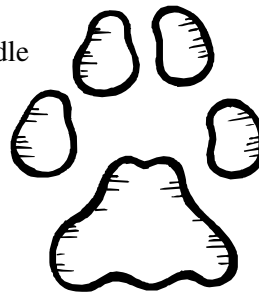

Cubmaster: As you keep the parts of this promise, the Light of Christmas will burn brightly within you for all the world to see. Are you ready to make the promise to yourself, your parents, and to the pack? (Cubmaster shakes head in yes motion. Boys should also shake their heads yes.)

Cubmaster: Then hold your candle in your left hand, give the Cub Scout sign with your right hand and repeat the Cub Scout Promise with me.

I promise to do my best, To do my duty to God and my country, To help other people, And to obey the Law of the Pack.

Cubmaster: The last thing you promised was to obey the law of the pack. This is the law that binds us all together. So let us all now repeat the law of the pack. Will all scouts that are here tonight please stand, give the scout sign and repeat the law of the pack with me?

The Cub Scout follows Akela.

The Cub Scout helps the pack go.

The pack helps the scout grow.

The Cub Scout gives goodwill.

(Cubmaster motions for audience to be seated.)

Cubmaster: We often talk of the Christmas Spirit, the magic of Christmas. Long ago and far away, Jesus taught that magic to St. Nicholas, or Santa Claus as he has come to be known. So to help bring the magic of Christmas spirit here tonight, I am going to divide the room into two parts.

# DECEMBER 2004 HOLIDAY FOOD FARE

## Advancement Ceremony

### THE LIGHT OF CHRISTMAS Continued

Cubmaster: When I point to you, I want this half to yell Santa and this half to yell Claus. Ready? One, two, three ...  
(Point to first half of the room and yell...)

Cubmaster: Santa! Ready? One, two, three ....

(Point to second half of room and yell...)

Cubmaster: Claus!

(Repeat the yell three times. At the end of the last yell, Santa enters...)

Santa: Ho, Ho, Ho! Merry Christmas!

Cubmaster: Oh, Saint Nicholas, we are so glad you could come! Would you please help us by adding some of your Christmas spirit to our ceremony?

(Santa nods and waves his hand over the punch. While waving his hand over the punch, he discretely drops a lump of dry ice that he has hidden in his palm into the punch. Or, if Santa is carrying a toy sack, he can reach into the sack for the dry ice.)

Cubmaster: Our cubs have shared the Light of Christmas. Now we want to be sure they are also filled with the Christmas spirit. Santa, will you please help me give these boys some of your Christmas spirit?

(Santa nods head. Santa fills cups with punch. Check for dry ice in cups! Cubmaster hands out the cups to the boys, telling them not to drink yet. If you have a small pack, you may consider giving all cubs present a cup. After the punch has been distributed, Cubmaster offers toast...)

Cubmaster: May your heart always be filled with the Christmas spirit. (Cubmaster and Santa drink, motion for boys to do the same.)

Cubmaster: You are now are filled with the Christmas spirit and carry the Light of Christmas in your hearts. Therefore, you no longer need your candles to show that light. Blow them out now. (Collect candles and cups.)

(Cubmaster and Santa now distribute badges and tiger pins. If you have a bobcat, you may say....)

Cubmaster: You are now bobcats in this pack. You have promised to help other people. Helping other people is called a doing a good turn. So that the pack can see that you are living up to your promise to help other people, we are going to put your bobcat rank on upside down. You may turn your rank around after you have done a good turn. When the pack sees your rank right side up, they will know that you are helping others.



Cubmaster: Saint Nicholas is very busy this time of year and needs to get back to the North Pole soon. To show him our appreciation, let's give him a big Cub Scout spirit cheer. I want this side of the room to shout Merry, and this side of the room to shout Christmas. Ready? One, two, three, Merry! One, two, three, Christmas!

(As the Cubmaster repeats the cheer two or three times, Santa makes his exit and can disappear.)

# DECEMBER 2004 HOLIDAY FOOD FARE

## Run On/ Applause

### RIDDLES

- What do turtles give each other for Christmas? *People-neck sweaters*
- What's the Christmas song monkeys like best? *Jungle Bells*
- If an athlete gets "athletes foot", what does an astronaut get? *Missile toe.*
- What is the weather forecast for Christmas? *Probably some rain, dear!*

**MELTING ICICLE:** Hang fingers down and do, "Drip, Drip, Drip."

**SNOWBALL:** Reach down and pick up some snow. Pack it into a ball. Pull Arm back, throw, and yell "SPLAAAAT."



**CHRISTMAS BELLS** Divide group in half. Group one says "Ding" Group two says "Dong" Repeat three times.

**SANTA** Rub your stomach while saying "Ho,ho, ho, Merry Christmas

**RUDOLPH** Put your thumb to you head, spread fingers to form antlers, wrinkle your nose while saying "Blink, blink, blink."

**MISTLETOE** Hold mistletoe with one hand above head and say "Smooch, smooch, smooch."

**WORKING ELF** Pick up hammer and say, Nail, nail, nail, Glue, glue, glue, Build, build, build."

**SNOW CHEER** Hold your hands over your head, bring them down slowly while wiggling your fingers, saying, "flaky, flaky, flaky."

**FROSTY CHEER** Fold your arms across your chest and shiver and say "BRRR, BRRR, BRRR".

# DECEMBER 2004 HOLIDAY FOOD FARE

## Closing

### DO A GOOD TURN DAILY

This does not mean that you are supposed to do one Good Turn during the day and then stop. On the contrary - it means you do at least one Good Turn a day. It means looking for opportunities to help and then helping, quietly and without boasting. Remember always that a Good Turn is an extra act of kindness, not just something you do because it is good manners.

### HOLIDAYS LIGHTS

National Capitol Area Council

**Cubmaster:** This is the season of lights. It is a time when the days are shorter so the nights are longer, yet somehow things are brighter. Stores and homes are bright with holiday lights. Thousands of homes have a single light to show the way for the Christ child, others have candles burning to commemorate the miracle of Hanukkah, and some light candles to honor the heritage of Kwanzaa.

Even the stars in the winter sky seem brighter at this time of year. But the most important glow is from the spirit of goodwill that **WE** live with year-round in the Cub Scout Promise and the Law of the Pack.

Before we all leave to get on with our holiday celebrations, let's stand and repeat the Promise and Law together. Happy Holidays!

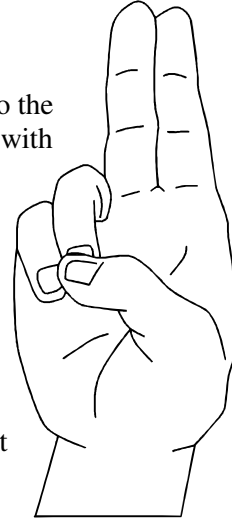

### GOOD TURN

Most of us are happiest when we are doing something for others. Think for a moment of a time when you were helpful to someone. Chances are, it made you feel pretty good. Of course, we feel best when we do something for others without being found out. When we help others regularly, it soon becomes a habit and to be a natural thing. Once you have establish this habit, you will learn the real meaning of the good turn.

### G-O-O-D-W-I-L-L

*PERSONNEL: - 8 Cub Scouts*

*EQUIPMENT: 8 Signs with the letters G O O D W I L L on them.*

*ARRANGEMENT: The Cub Scouts enter one at a time, holding up sign with a letter on it. Each speaks his line and the next Cub Scout enters. When the final Cub Scout joins the group, the letters will spell GOODWILL.*

**G** - Good Cub Scouts are fiends to all.

**O** - On their honor to obey the Pack Law.

**O** - Once they spread good will all around.

**D** - Doubled friendships will surely be found.

**W** - Working together to make the universe a better place.

**I** - Including as friends, boys from each faith and race.

**L** - Leaving behind them a path of good cheer.

**L** - Let's all practice it now and all through our years.

# DECEMBER 2004

## HOLIDAY FOOD FARE

### Holiday Food to Make in Your Den and Enjoy!!

#### Fruity Popcorn

8 cups popped corn  
1/3 cup melted butter  
1 package any flavor gelatin

1. Place popcorn in clean sack.
2. Pour butter over popcorn, close sack, and shake well.
3. Sprinkle gelatin over popcorn, close sack, and shake well.

#### Christmas Gift Jar for Fruity Popcorn

To make this gift jar, you will need: any clean, clear glass jar with wide mouth (mayonnaise jar is good), Christmas wrapping paper or old Christmas cards, scissors, green or red felt (optional), pencil, glue, and ribbon or bow.

1. Cut out pictures from wrapping paper or cards; glue to sides of jar.
2. Trace around lid onto felt, then cut out and glue to top of lid (optional).
3. Fill with Fruity Popcorn or other treats; tie with ribbon or put bow on top.

#### Easy French Toast

1 1/4 cups egg nog  
8 slices bread

Pour egg nog into shallow bowl. Dip bread into egg nog. Cook bread in hot greased skillet or griddle until golden brown on both sides. Serve with syrup or powdered sugar.

#### Wassail

- 1/2 cup sugar  
4 cups boiling water  
3 whole allspice  
6 whole cloves  
1 tablespoon ground ginger  
1 piece stick cinnamon 1" (2.5 cm) long  
1/3 cup orange juice  
2/3 cup lemon juice
1. Pour sugar into 2 cups boiling water; boil 5 minutes.
  2. Add spices; cover and let stand 1 hour.
  3. Add remaining water and fruit juices; mix well, then strain.
  4. Reheat to boiling. Serve warm.

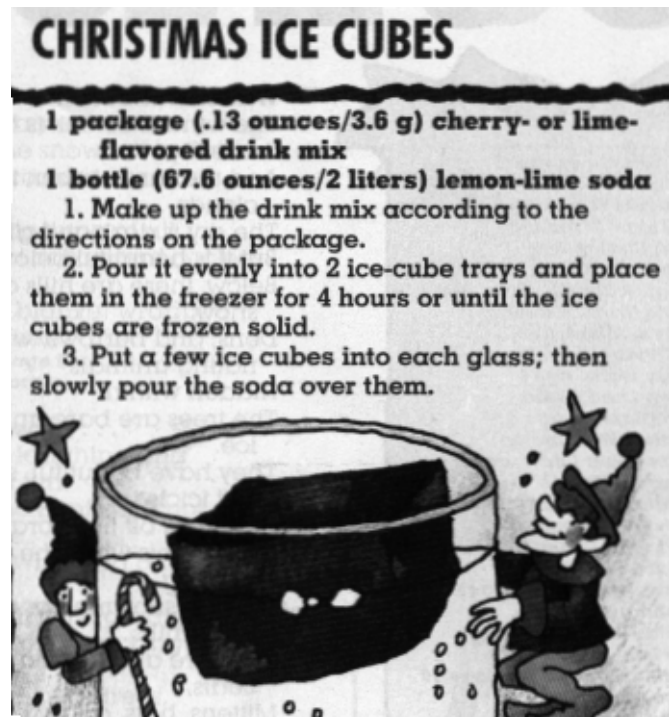



# DECEMBER 2004

## HOLIDAY FOOD FARE

### Yum Yums

- 1 package caramels
- 1 package marshmallows
- 1/2 box crisp rice cereal

1. Unwrap caramels and place in heavy saucepan. Melt caramels over low heat, stirring constantly.
2. Pour cereal into deep bowl.
3. Stick fork into marshmallow, dip marshmallow into caramel sauce, then into cereal. Place finished candies on waxed paper.
4. Eat at room temperature, but refrigerate to keep fresh.

### HANUKKAH DOUGHNUTS

Make with adult help

- Ingredients*
- 1 2/3 cups flour*
  - 2 eggs, beaten*
  - 1 tsp. baking powder*
  - 1 cup sour cream*
  - 2 Tbsp. sugar*
  - 1/2 tsp. salt*
  - 1 cup powdered sugar*
  - 1 cup oil for frying*



### Direction

In large bowl, combine all ingredients except powdered sugar and oil.

In frying pan, heat oil to medium heat.

Carefully place dough into oil, 1 Tablespoon at a time.

Fry 3 - 5 minutes or until golden brown all over.

Carefully remove doughnuts from oil and place on paper towels to drain.

Gently roll warm doughnuts in powdered sugar and set aside.

Serve warm

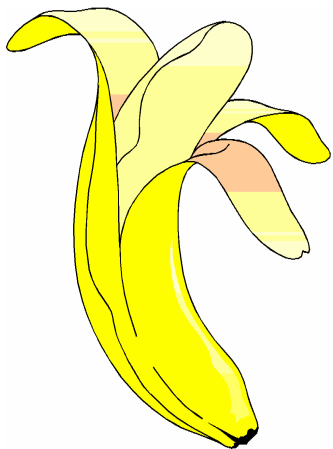

### KWANZAA BAKED PLANTAINS

- Ingredients*
- 4 - 5 ripe, large plantains*
  - 1/2 tsp. cinnamon*
  - 1/2 tsp. nutmeg (optional)*
  - 1/3 cup brown sugar*
  - 1/4 cup butter or margarine, melted*

Serve warm.

Directions

Preheat oven to 350 F.

In small bowl, combine sugar, spices, and butter and stir to combine.

Wash plantains and cut in half lengthwise.

Place in baking dish, peels facing down.

Drizzle sugar mixture over plantains.

Bake for 30 minutes or until soft.

# DECEMBER 2004

## HOLIDAY FOOD FARE

### CANDY CANE REINDEER

*Candy Cane*

*Brown or green pipe cleaner*

*Red pom pom*

*Wiggly eyes*

Cut pipe cleaner in half. Cut one half in half again. Twist pipe cleaners to form antlers. Glue on eyes and nose. DON'T UNWRAP PLASTIC FROM AROUND CANDY CANE.

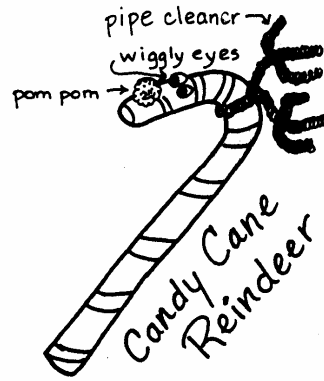

### CARAMEL MARSHMALLOW TREAT

1 lb Kraft caramels

1/2 cube margarine

1 can Eagle brand sweetened condensed milk

Rice Crispies

1 package large marshmallows.

1. Stir in a double boiler caramels, margarine and condensed milk until melted.
2. Dip marshmallows in caramel mixture with fork, roll in rice crispies and cool.

### GUMDROP TREES

1 tbsp shortening

4 cups puffed oat cereal

3 tbsp butter or margarine

3 cups miniature marshmallows

1/2 tsp vanilla

Gumdrops

1. Grease cookie sheet with shortening. Empty puffed oat cereal onto cookie sheet.
2. Heat miniature marshmallows over low heat. Stir constantly until they melt.
3. Remove from heat and stir in vanilla.
4. Pour mixture over cereal and stir with tablespoon until entirely coated.
5. Butter your hands and shape the coated cereal into 6 Christmas trees.
6. Cut gumdrops with scissors and decorate trees with the slices.

# DECEMBER 2004

## HOLIDAY FOOD FARE

### RUDOLPH ANTLERS

These can be made in a jiffy, but need to be chilled. Make a few ahead of time so the boys can taste it. Make a batch (or two) together and send theirs home to be refrigerated.

1 6-oz package semisweet chocolate pieces  
1/2 of a 6-oz package butterscotch pieces  
1 3-oz can of chowmein noodles  
12 Maraschino cherries, halved

1. Melt chocolate and butterscotch pieces together in a medium saucepan over low heat, stirring occasionally. Remove the pan from the heat. Stir in chowmein noodles.
2. Line a cookie sheet with waxed paper. Using two teaspoons, shape about 1 tablespoon of the mixture into a v-shape cookie about 2 inches wide to resemble antlers.
3. Press a cherry-half in the center of each. (Make sure you press the cherries securely.)
4. Chill cookies on the cookie sheet in the refrigerator for 1 to 2 hours or till cookies are firm. Store the antlers in the refrigerator in a covered container up to 5 days.

**Makes 24**

### **Tiger Butter**

Makes 24 servings

#### **Ingredients:**

16 ounces white chocolate, chopped,  
3/4 cup crunchy peanut butter,  
1 cup milk chocolate chips

#### **Directions:**

Butter a 10x15 pan. Set aside.  
Place white chocolate in a medium-sized microwave-safe bowl.  
Microwave on High until melted, stirring frequently.  
Stir in peanut butter.  
Spread into prepared pan.  
Drizzle with melted milk chocolate chips, stirring through mixture to create a marbled effect.  
Let stand until set.  
Break into bite-sized pieces.

# DECEMBER 2004 HOLIDAY FOOD FARE

## Craftsman

### PAINTBRUSH CLEANER RACK

Base is 1" x 5" x 6"

Side supports are each 1" x 2" x 12"

1. Cut a notch in center of each side of base 1 3/4" wide and 3/4" deep.
2. Sand all rough edges.
3. Drill a 1/4" hole in center of each side support, about 3/4" from end.
4. Glue or nail 12" strips into notches in base.
5. Cut a 7" piece of wire coat hanger.
6. Put a 1lb. Coffee can on base and fill with solvent.
7. Suspend brushes on wire held by side supports.

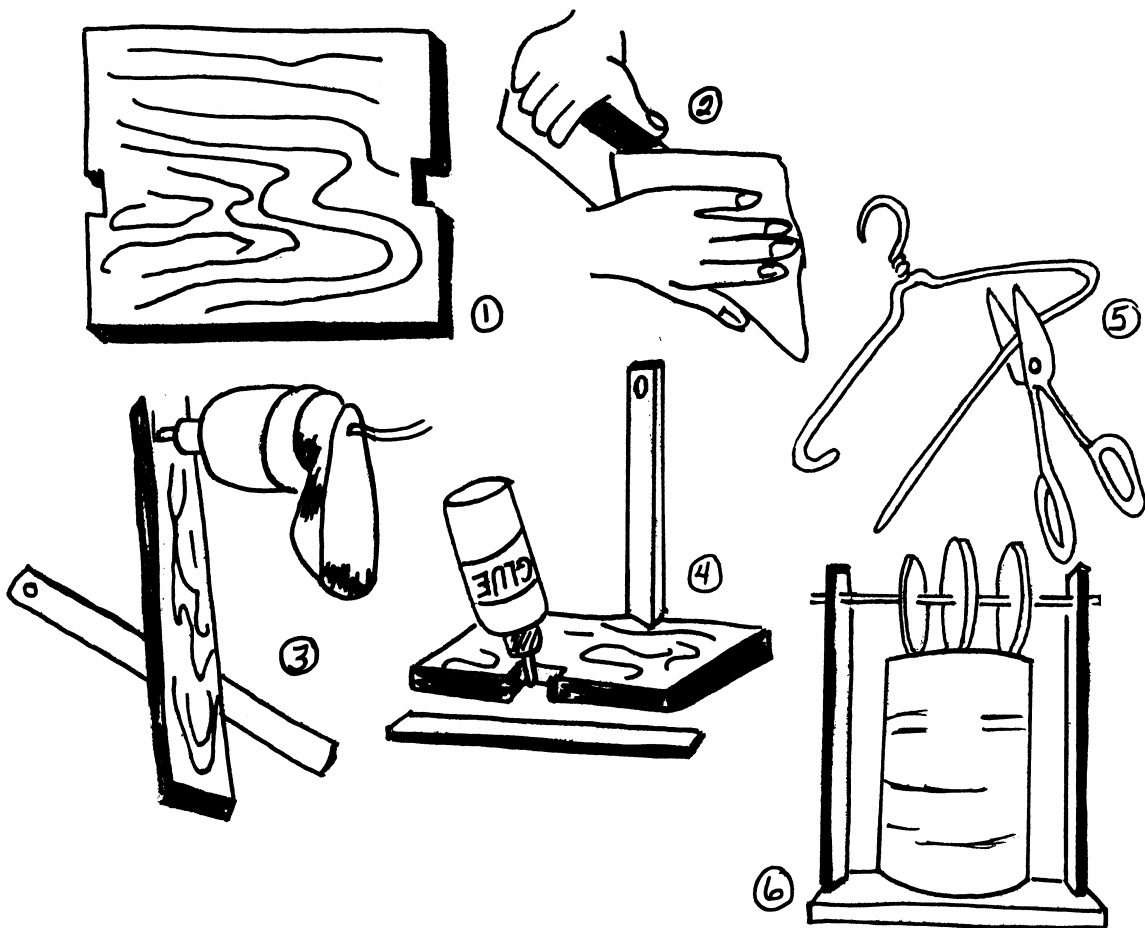

# DECEMBER 2004 HOLIDAY FOOD FARE

## Craftsman

### WOODEN GIFTS

#### DISH BRACKET.

Trace the pattern. Cut the back out of a  $\frac{1}{2}$ " pine. The two feet are pieces of  $\frac{1}{4}$ " plywood. Sandpaper and paint or stain.

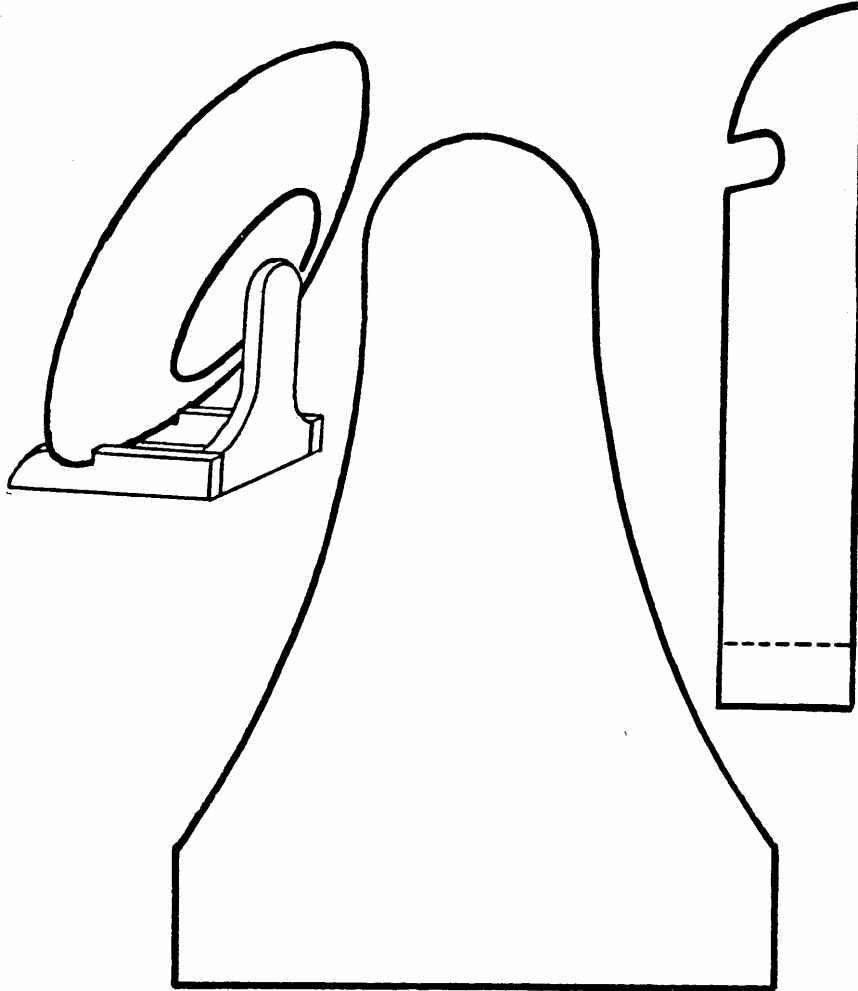

#### PLANTER

This is designed to accept an aluminum foil loaf pan as a lining.

The two side pieces are cut from  $\frac{1}{2}$ " plywood. The dotted base line indicates the size of the piece required for the foot of the cradle; the solid line is the head of the cradle. The ends, the rockers and the support are cut from  $\frac{1}{2}$ " pine.

Nail pieces (side) to the head and foot ends. Nail two rockers to ends of center support. Now insert this in the bottom of the cradle. When properly positioned, nail. Finish as you desire.

# DECEMBER 2004

## HOLIDAY FOOD FARE

### Scientist

Scientists do what Webelos Scouts do best – ask questions. The Scientist activity badge allows Webelos to see a glimpse of the things that confront scientists every day and to ask “why did that happen?” In earning this badge they will be exposed to the notion of experimenting as a way of answering scientific questions. They will learn that they are the next generation of experimenters, and will learn about famous scientist and their experiments. They will learn that the universe is full of magical things waiting patiently for you to find them out.

The Internet is a great source for finding experiments that can tie into your activity badge. One of the best sites that I found was: The Exploratorium Science Snacks one such experiment is listed below. For a more detailed listing from A to Z. You will need to go to: <http://www.exploratorium.edu/snacks/snackintro.html>

#### BERNOULLI LEVITATOR

**Suspend an object in the air by blowing down on it**

**The Bernoulli principle explains how atomizers work and why windows are sometimes sucked out of their frames as two train's rush past each other.**

**Materials:**     *A large wood or plastic thread spool  
                          An index card, A pushpin  
                          Optional: Drinking straws*



#### ASSEMBLY

(5 minutes or less)

Trim an index card to a 3 x 3-inch square.

Push the pushpin into the card's center.

If more than one person is going to use this, construct the following sanitary version: Cut a 2 inch long piece of straw for each person. At each person's turn have him push one end of the straw into the hole in the spool of thread. If any straw does not fit, cut a 1/2" slit near the end of the straw and push it into the spool.

#### TO DO AND NOTICE

(5 minutes or more)

Hold the card against the bottom of the spool with the pushpin sticking into the spool's hole. The pushpin keeps the card from drifting off to the side. Blow strongly through the hole in the top of the spool and let go of the card. If the card falls at first, experiment with different sized cards or spools until you can make the card hand suspended beneath the spool

#### WHAT'S GOING ON

When you blow into the spool, the air goes through the opening, hits the card, and accelerates outward. The energy needed to accelerate the air comes from the energy stored as compression of the gas, so the gas expands, and its pressure drops.

As air (or any other fluid) accelerates, its pressure drops. This is known as the Bernoulli principle, The air rushing between the spool and the card exerts less pressure on the card than the still air underneath the card. The still air pushes the card toward the spool and holds the card up against gravity.

#### FYI

In an atomizer, or perfume sprayer, you squeeze a rubber bulb to squirt air through a tube. Because of the Bernoulli principle, the air rushing through the tube has a lower pressure than the surrounding atmosphere. Atmospheric pressure forces the perfume up an intersecting tube into the low-pressure air stream. The perfume is pushed out of the tube and sprays into the air as a fine mist.

# DECEMBER 2004 HOLIDAY FOOD FARE

## Scientist

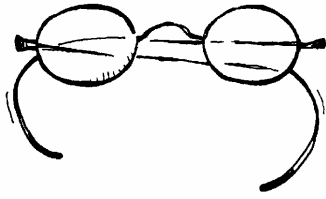

### PENDULUM PHENOMENON

#### *An Optical Illusion*

Fasten a white disk  $\frac{3}{4}$ " in diameter on a 3' piece of white thread. Have someone hold thread so the disk can swing like a pendulum. Start the disk swinging in a perfectly straight line and view it from a distance of three feet against a plain wall. Notice how the disk swings in a line like a pendulum. Hold a sunglass lens over one eye. Observe the path of the swinging object again. The movement will no longer be in a line, but in a circle. If you switch the lens to the other eye, the movement will appear to be in the opposite direction. This shows the importance of the eyes receiving similar images.

### TEST YOUR TASTE JUST FOR FUN

*Materials: Estimated Cost*

*\$2.00*

*4 resealable plastic bags,  
labeled SALTY, SWEET,  
BITTER, and SOUR*

*2 Tablespoons of each of the  
following in one of the bags:  
salt, sugar, instant coffee  
(bitter) and unsweetened  
powdered*

*Lemon drink mix.*

*1 box of flat toothpicks, paper  
cups, candy, tissues*

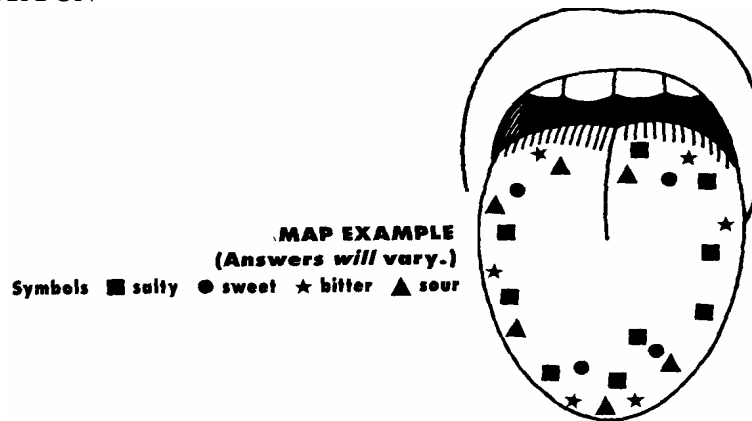

**OBJECTIVE:** To locate areas of the tongue that respond to the four basic tastes: Salty, sweet, bitter, and sour.

**PROCEDURE:** Photocopy tongue map. Gather materials listed. Fill a paper cup with water. Dip a toothpick into the water, then dab it in the salt. Touch the salty end to the tip, middle, sides, and back of your tongue. Each time you taste the salt, draw the symbol for salty on that area of your tongue map. Where the taste is weak make a small symbol. Stronger make a larger symbol. Throw away your used toothpick. Swish a sip of water to clear your taste buds. Repeat for all the other samples.

**Compare your tongue map with the others. You'll notice that like fingerprints no two people of the same types of taste buds.**

### ANSWER THESE QUESTIONS:

What do you think will happen if you

1. Touch a salty toothpick only to the inside of your cheek or the underside of your tongue?
2. Dry the tip of your tongue with a tissue then put a pinch of dry sugar on it?
3. Taste a piece of candy on the back of your tongue?

### ANSWER:

You won't taste anything.

Food must be wet for taste buds to work. Dry sugar on a dry tongue has no taste at all.

The candy won't taste very sweet.

# DECEMBER 2004 HOLIDAY FOOD FARE

## Scientist

### TEST YOUR TASTE JUST FOR FUN continued

#### CHALLENGE QUESTION!

Objective:

To discover how your nose helps you taste

Materials:

Piece of apple, piece of onion

Procedure:

Hold the onion under your nose with the strong odor of onion in your nose, chew on the apple.

Question: What does the apple taste like? (Part onion, part apple)

Explanation:

Out tongue can taste salty, sweet, sour, and bitter. But our sense of smell picks up additional flavors and makes it possible for us to detect thousands of delicious or yucky tastes.

When chewing food you don't like, hold your nose or sniff a piece of strong smelling food that you do like.

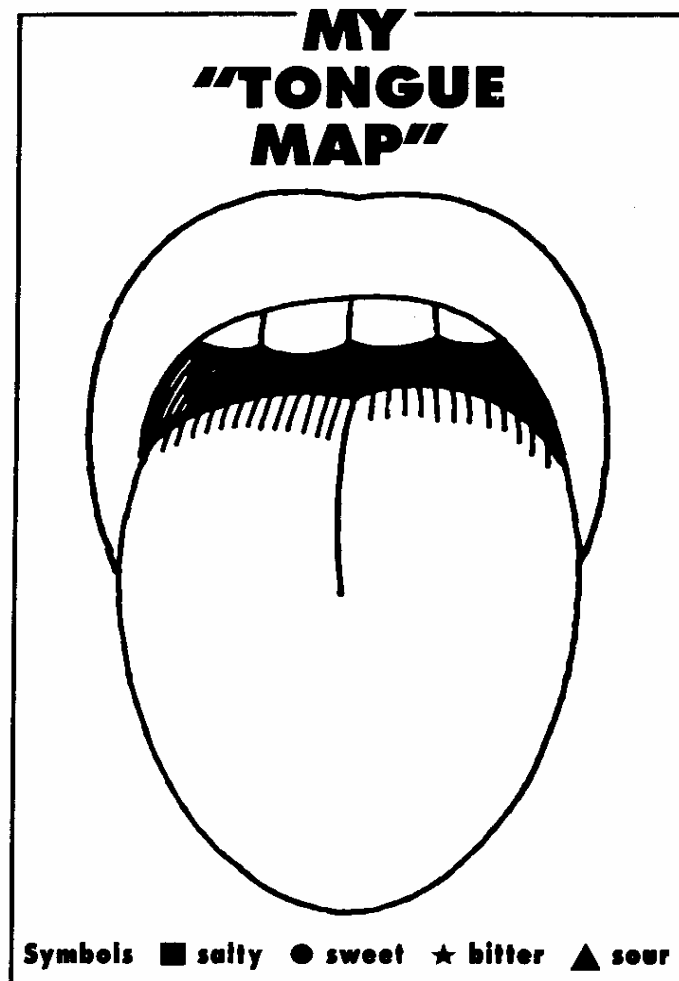



# DECEMBER 2004 HOLIDAY FOOD FARE

Tigers - Where I Live

## Family Activity

### WHAT FAMILIES CAN DO TO HELP THEIR COMMUNITY



**A**dopt a stream, park or roadside to clean up and keep beautiful.



**B**ring your lunch to school in a lunch box. Save your paper bags.



**C**are for toys so they will last longer. Then you won't have to replace them and can pass them on.



**D**onate clothes that you have outgrown to a needy person or someone smaller.



**E**ncourage others to join you in collecting glass, newspaper and aluminum to be recycled.



**F**latten empty cans, boxes and other containers so they don't take up so much space.



**G**et in the habit of turning off the water when you brush your teeth. Turn it on only to wet your brush and to rinse.



**H**elp by caring about our wildlife. Be very careful with matches.

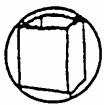

**I**nsist on buying products that are biodegradable (they rot or decompose when discarded.) Most plastics are not.



**L**og or walk, ride a bike or scooter from place to place to save energy.



**K**eeP jars of cold water in the refrigerator so you won't have to run the tap water waiting for it to get cold.



**L**ook for the recycled symbol on products you buy.



**M**ake it a habit to cut each six-pack ring. These sometimes wind up in the oceans. Animals often get caught in them.



**N**ever litter. Always put your trash in a trash can.



**O**pen the blinds in the wintertime to let in the sun. Close blinds in the summer to keep out the sun's heat.



**P**lant a tree to stop soil erosion, give you shade and give birds a home.



**Q**uit buying products that have a lot of packaging.



**R**educe the amount of water you use to keep clean. Take showers, not baths.



**S**ave energy by asking your parents to turn down the thermostat.

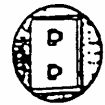

**T**urn off lights if you are the last person to leave a room. Turn off appliances if you are not using them.



**U**se products made to be used many times, such as sponges or cloth towels.



**V**alue and appreciate your Earth. Realize that you can make a difference.



**W**atch what you pour down the drain. Hazardous waste can get into the ground water.



**X**amine labels before using products. Certain household cleaners can be dangerous.



**Y**earn to do what you can to help our environment. Grow up to be an adult who takes an interest, too.



**Z**ip to close doors and windows if they are opened when the heater or air conditioner is on.

# DECEMBER 2004 HOLIDAY FOOD FARE

## Tigers - Where I Live

### Family Activity

- ◆ Have a block party
- ◆ Visit a place of worship different than your own.
- ◆ Take a town hike or bike trip.
- ◆ Plan a vacation at home - find new places to see and visit in your own town or area.
- ◆ Visit the library and get a library card.
- ◆ Visit your neighbors.
- ◆ Invite your pastor, rabbi or bishop to dinner.



### Den Activity

#### WALK AROUND THE BLOCK

- Shadow Walk:** Walk only in the shadows, that may require some jumping. (Don't plan this walk at noon since that is when shadows are their shortest)
- Smell Walk:** Sniff your way around the block. Write down the odors you recognize, and draw a picture of what causes those smells. Label how you feel about each smell.
- Color Walk:** Choose a color like red and walk only toward red object for as long as you can. Can you make it all the way around your block? Write a history of your color walk. You might try drawing a map of it.
- Sound Walk:** Listen your way around the block. Write down the sounds you recognize. Draw a picture of the things, which cause these sounds. Label how you feel about each sound.

### Go See It Outing

- Visit a nursing or retirement home.
- Take a tray of favors for the children's ward of a hospital.
- Visit community organizations that give aid to the needy.
- Visit a recycling center. Take aluminum cans and or plastic containers.
- Visit a bakery, restaurant, or store.
- Visit city hall, fire station, hospital or police station.
- Visit museums, zoos or historical sites.

# DECEMBER 2004

## HOLIDAY FOOD FARE

### Cubmaster Corner - The L's - Learn, Laugh, Lead

As in the life of an individual, so in the life of the Cubmaster there are certain distinct ages - certain periods of thought and action, each one a progression toward perfection. Let us try to picture these ages through the simple medium of hats.

#### ***FIRST - The HAT of the BABY:***

Here you see then - the Cubmasters - in a baby's bonnet, just born into Scouting, without knowledge - with just the idea to get on somehow, to keep a pack running, to exist. Every plaything pleases him for the moment. Each new idea attracts him in turn. He is pulled this way and that way by every new experience. There is no purpose or program. Just motion. Sometimes forward, sometimes backward - mostly sideways.

And so we leave him - poor soul, bewildered, puzzled, with the complexity of it all, and we come to ....

#### ***The HAT of a CHILD:***

Look at him now...kid among kids. He thinks to be successful as a Cubmaster he must be a kid again in word, in thought, in action, "King of the Kids" they call him. He must run the pack solely on the good time principle. "They are only boys" he says, "I can't expect much of them." And so expecting little, he gets little. The noise the pack makes is terrific. The motion the pack makes is gigantic. The accomplishment is nothing. This is the age of treats, of thinking that one can buy ones way into the respect of boys. It is the age of joshing, of fooling, of playing at Scouting.

He leaves us now, discouraged because it hasn't worked and changes his tactics so that he next appears in....

#### ***The HAT of the MILITARIST!***

He has become "hard boiled." Yes, sir, he did everything for those kids, and they didn't appreciate it. "They have to be ruled with an iron hand." He says. "I'm running this pack. Do as I tell you. Never mind suggestions. I'll make up the program. Cut that out, you stop that, do this, do that, go here, go there. I'll run the meeting. I'll issue the commands."

It's said especially as disillusioned, dejected, broken, he appears next in....

#### ***The HAT of the DUNCE***

So, you see him in his cap of ignorance. He has tired and failed. He's decided he doesn't know how. He admits it. He thinks he'll quit. He can't learn, It can't be done. But then other men have succeeded. There must be a way,

So next he appears --willing, hopeful, trying, in..

#### ***The HAT of the THINKER***

He puts on his thinking cap. He thinks. He reasons. He observes other Cubmasters. He investigates. He finally made it to Cub Basic Training and he's going to the monthly Roundtables. He accepts training and the experience of others. At night, in bed, he considers and plans. He seeks out fundamental principles. He clarifies his ideals. He selects tried and true methods. He sticks and doesn't quit, and all of a sudden he finds himself.



# DECEMBER 2004

## HOLIDAY FOOD FARE

### Cubmaster Corner - The L's - Learn, Laugh, Lead

And so he appears in the last and final hat..

#### ***The HAT of the SKIPPER***

You see him now wearing the hat of the captain of the ship. He has become master of his organization. Like a skipper, he is on the bridge in full command, directing, piloting, and leading. Each department of his pack, though a separate unit in itself working by itself, is under his full control. There is no confusion, no wasted motion, and no conflict. Every man has a job and so long as he does his job well, the skipper can give the pack the direction that it needs.

And now we leave him, sailing the high seas of Scouting, prepared alike for calm or storm. He is the master and his organization is with him.

May you all wear the hat of a skipper...it's so much more comfortable than any of the others.

*Adapted for Cubs by Ellen Hansen-- Portland, Oregon*

#### **A LEADERS RESOLUTION**

I shall study my boys so that I may understand them.

I shall like my boys and leaders so that I can help them.

I shall learn - for they have much to teach me.

I shall laugh - for youth grow comfortable with laughter.

I shall give myself freely - yet I shall take,  
so that they may acquire the habit of giving.

I shall be a friend - for a friend is needed.

I shall lead - yet I shall be aware of pushing.

I shall listen - for a listener prevents combustion.

I shall warm them when my experience warrants it.

I shall command when action merits it.

I shall overlook mistakes - yet I will not blame them.

Lastly, I shall try to be that which I hope they think I am.

***A leader who can say they have been able to Learn, Laugh and Lead!***

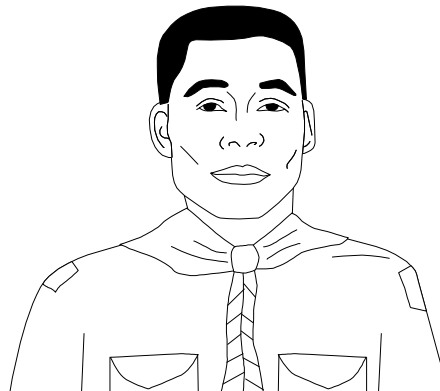

# CUB SCOUTS SPREAD THE NEWS

## January 2005

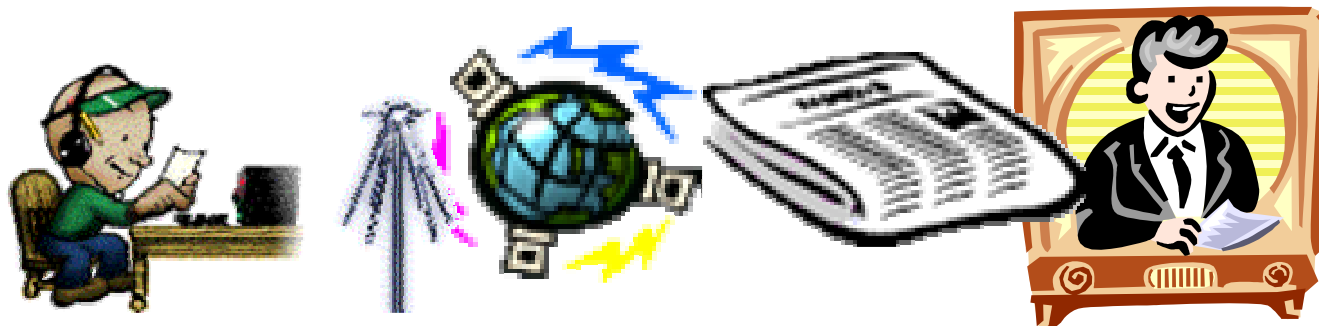

Let's make news for the New Year. Cub Scouts can make headlines this month and learn about the history of news reporting. The pack spreads the good news about Cub Scouting by inviting the local radio, TV or cable channels to the pack meeting or the upcoming blue and gold banquet. Plan field trips to visit them at their workplace. Dens can publish articles and pictures in a den or pack newsletter or make their own videotape to be shown at the pack meeting or next months blue and gold banquet. Let your Cub Scouts experience the different roles on a news team and hold either a press conference or a news broadcast at the pack meeting. Use props and scripts created by the boys and a camcorder to record the broadcast or pack events. Cub Scouts can learn many different ways to spread the "news" about Scouting this month.

Cub Scout Theme.....	03
Webelos – Fitness .....	34
Webelos – Readyman .....	40
Tigers - Keeping Myself Healthy and Safe .....	43
Cubmaster Corner - Arranging For Special Guest .....	46

# CUB SCOUTS SPREAD THE NEWS

## January 2005

### **TIME IS OF THE ESSENCE**

The key to a happy child is having a parent who is there with him consistently, day in and day out. It is far better to spend evening after evening just sitting near him while he reads a book or plays on the computer than to spend a couple of hours every Saturday buying him toys or taking in a movie.

### **SHARE YOUR STRENGTHS AND FEARS**

You are your child's ally, not his adversary. The child, who knows that his parent was once afraid of the dark, and is still afraid of needles, gets to know that his own weaknesses are part of mankind, not a unique shame.

### **LOOK FOR THE GOOD AND PRAISE IT**

Encouragement is the primary engine of human development. I have been telling my son for over a year that he is a whiz in math because I know he can calculate in a nanosecond the number of toys he can buy with his allowance. Now he's a whiz in math at school too. Consistent recognition of a child's strengths is more important by far than vitamins. You deny it to them at their peril and yours.

### **DO NOT ALLOW YOUR CHILDREN TO BE RUDE**

My son is expected to share, answer others when they greet him and congratulate those who succeed. By teaching him about politeness, I make sure he realizes that others' feelings are worth taking into account. If he can get that in his head he will have learned the most basic foundation of human interaction.

### **LET YOUR CHILD TEACH YOU**

A common misstatement about child development is that "kids don't come with instruction manuals". Au contraire - they do. They tell you when they're hungry. They tell you when they're lonely or scared. They are little guided tours of themselves. Children will tell you what they want, although not always with words. Fatigue, irritability and sadness are ways of telling parents what they need. Look and listen.

### **VALUE YOUR CHILD FOR WHAT HE IS**

When my son knows he is loved for himself, not for any particular accomplishment, he has a certain peace that allows him to learn better, sleep better, play better, and be more helpful around the house. Whether he becomes a rocket scientist or a plumber, I want my son to know he's No.1 with me.

### **BEING A PARENT IS YOUR TOP PRIORITY**

If you decide your kids come before your sales quota or other activities, you will find that all the other pieces of parenthood fall into place. When you put your kids first, you're getting the most value for every hour on earth. What's more, you have made the most Righteous decision of your life.

Author Unknown  
From Circle Ten Council



# CUB SCOUTS SPREAD THE NEWS

## January 2005

### Gathering Activities

#### **Noodlegrams**

Simon Kenton Council

In a saucer place a tablespoonful or more of uncooked noodles. Each person must try to compose a ten word message out of the alphabet noodles. This could be done in couples or singly as gathering time activity.

#### **Jigsaw Puzzle Ads**

National Capital Area Council

Cut up full page color pictures from magazines. Have at least one puzzle per scout. As each scout arrives, hand him one to put together. If time permits, let the scouts exchange puzzles.

#### **Who Am I?**

National Capital Area Council

Make up a "Who Am I" card for each scout. This card has the name of someone who is famous or well-known in some field of communication -- past presidents, politicians, actors, radio personalities, etc. Tape one card on the back of each scout as they arrive (be sure the scout does not see the name). The scouts are allowed to ask each scout two questions which can only be answered with "Yes" or "No" as they try to guess "Who" they are.

#### **Amazing Numbers**

You will need a calculator for this:

Take the number of the month you were born,

multiply by 4,

add 13,

multiply by 25, subtract 200,

add the day of the month on which you were born,

multiply by 2, subtract 40, multiply by 50, add the last two digits of the year in which you were born,

subtract 10,500.

Notice anything funny about your answer

#### **Story Box**

Use already-made boxes or boxes that Cubs have made themselves., let their imaginations go! A Storytelling Box can also be done individually or as a group. It is a special box into which the following kinds of items, or combinations are placed:

Small, smooth stones (or ceramic squares) onto which words, signs or symbols are painted, or written on.

Small, unusual objects (e.g. toys, things from nature, household items, small bits of clothing, coins, and so on).

Slips of paper or flat sticks with words or pictures on them.

Cubs work in groups of 3-5. The Den Leader can start off with a beginning, then allow one of the group members to "set the stage", or leave it completely up to the individual storyteller from the very start.

The first Cub begins by drawing out an object from the box without looking (the element of surprise makes it more interesting!) . The drawn item must be used sequentially in the story and stays out of the Box until the story is finished; i.e. it can't be put back into the box and exchanged, or saved until later in the story, or used again.

The story continues until such time as the Cub becomes "stumped", and pulls out another object. This process continues until the Cub determines that the story is finished.

# **CUB SCOUTS SPREAD THE NEWS**

## **January 2005**

### **Gathering Activities**

#### **How Many Words?**

York Adams Area Council

See how many words each person can find in the phrase "Did You Get My Message?"

#### **Who Is It?**

Give everyone a 3x5 card. Have them all write down 4 things about themselves that no one else in the room should know. Have them put their name on the top of the card for future reference. Collect the cards. Then pass out a piece of paper to each person. Read the cards one at a time and have everyone write down who they think the person on the card is. Then read off the correct results (the names from the top of the cards) while they check their lists. The person who gets the most right is the winner.

#### **Who Am I?**

Take a pile of 3x5 cards and write down a name of a person or character on each card. These names can be seasonal (Winter: Cupid, Jack Frost, New Year's Baby, Old Man Time, etc.) or follow a theme (Presidents, George W. Bush, Kennedy, Jefferson etc.). Then tape a card to the back of every person in the room. They must now try to guess who they are by going around the room asking other people questions about the name on their back. These questions must be yes-no questions (ex. Q. "Am I green?" A. "Yes") and only one question can be asked to each person in the room (to get everyone talking to everyone else). The first person to guess the name on their back is the winner.



# CUB SCOUTS SPREAD THE NEWS

## January 2005

### Openings

#### Stop the Presses Opening

Trapper Trails Council

**Personnel:** Five Cubs

**Equipment:** A rolled newspaper for each boy

**Set Up:** The Cub Scouts run onto stage. As each Cub Scout repeats his part, he opens the paper to "read"

**All Cubs:** Extra! Extra! Let us read to you all about it!

**Cub # 1.** Wow! The headline says there's going to be a great Pack meeting for Pack (number) tonight! Sounds like fun!

**Cub # 2.** Hey! The Who's Who page says there's going to be some advancements and awards given out. That sounds neat!

**Cub # 3.** Would you look at the sports page? It says there's going to be fun games and activities for everyone. This is sounding exciting!

**Cub # 4.** Cool! The food section talks about the great refreshments that will be served. I know I can't wait!

**Cub # 5.** Hey Guys! In the comic section it says there's going to be some hilarious and funny skits and jokes. You know, that reminds me of a joke. What's black and white and black and white and black and white and black and white and read all over? A zebra, skunk, and Dalmatian reading a newspaper! Great joke, huh?!

**All Cubs:** Now that we've let you know what's going on we hope you'll enjoy the pack meeting as much as we will!!

#### Stop The Presses

Greater St. Louis Area Council

(Scout holds up "headline" from newspaper which states "Man Lost in Fog").

**Narrator (or another Cub):** This 1909 headline is important to all of us because it marks the beginning of Scouting in America. A Chicago businessman, William Boyce, was lost in a London fog. A Scout helped him find his way and the rest is history.

*You could probably develop this one further by adding in a few more Scouting headlines from the Scout history information found in the February 2005 section.*

# CUB SCOUTS SPREAD THE NEWS

## January 2005

### Welcome

Simon Kenton Council

**Equipment:** Seven pieces of construction paper each with one letter from the word **WELCOME** written on it. Cubs arranged to spell out the word.

**Cub # 1. (W)** 'We've come here tonight to communicate with you.

**Cub # 2. (E)** Each boy showing and telling what he can do.

**Cub # 3. (L)** Let's all lend an ear for the message.

**Cub # 4. (C)** Come now and direct your attention this way.

**Cub # 5. (O)** Opening this meeting we're doing right here.

**Cub # 6. (M)** Making for you a message soon dear.

**Cub # 7. (E)** Everybody welcome is what we wish to communicate now to you and to tell you this meeting has now started, too!

**Cub # 8. (Go into flag ceremony and Promise or Law or Patriotic Song)**

### It Takes Work To Communicate

York Adams Area Council

**Equipment:** Eleven pieces of construction paper each with one letter from the word **COMMUNICATE** written on it and the Cubs part written on the back in BIG letters. Each Cub should draw a communications picture on the front around his letter Cubs. Make sure the Cubs are arranged to spell out the word.

**Note:** Cubs 1, 13 and 14 may be Adults or Den Chiefs who are helping with the ceremony.

**Cub # 1.** So often we have problems in our lives because we don't "Get the message." Tonight our Cub Scouts will review some basic rules needed to communicate properly.

**Cub # 2.** C stands for "Carefully" – Carefully listen when someone is telling you something.

**Cub # 3.** O stands for "One" – One and only one person is "transmitting" at a time; other person should be "receiving."

**Cub # 4.** M stands for "Message" – Make sure you send the right Message when you communicate.

**Cub # 5.** M stands for "Minute" – Give the message a minute to sink in before responding.

**Cub # 6.** U stands for "Understand" – Make sure you understand the message before ending a conversation.

**Cub # 7.** N stands for "Noise" – Noise is what keep you from getting the message—noise from outside and inside your head. Avoid the noise!

**Cub # 8.** I stands for "I" – I am responsible for getting the message straight.

**Cub # 9.** C stands for "Carefully" – Carefully choose your words when you are sending a message

**Cub # 10.** A stands for "Attention" – Pay attention when you are sending and receiving a message.

**Cub # 11.** T stands for "Time" – Take your time to say things clearly and to hear things clearly.

**Cub # 12.** E stands for "Everyone" – It is everyone's job to make sure the message gets across.

**Cub # 13.** If we follow these rules, we will always be able to **Communicate!**

**Cub # 14.** (Now Flag Ceremony, Promise or Law or Patriotic song)

# CUB SCOUTS SPREAD THE NEWS

## January 2005

### Den Activities

#### **Pack Newspaper**

Santa Clara Council

It doesn't have to be fancy nor computer-generated. Boys can hand-write their articles and illustrate them. Or adult can help type their articles. Cut and paste the articles and illustrations. Involve the boys. They like to see their own names in print.

At the pack meeting, set aside some time for "interviewing." Boys can interview Cub Scouts and ask them specific questions like their favorite Cub Scout activities, and their favorite after-school snack, etc. Make it short and simple. They can write a rough draft at the pack meeting and finish it up with illustrations at the den meeting. Each den can have their own page in the newspaper. Don't forget the news from the dens. (All of this ties in with Bear Achievements 8 and 18.)

#### **How To Make Your Own Newspaper**

Santa Clara Council

1. **Get started:** Think of a name for your newspaper and decide which stories to include.
2. **Gather the Facts:** Interview people who have information. Visit the location where the story is taking place.
3. **Write the story:** Make an outline or rough draft first--all news reporters do that. Put the basics of WHO, WHAT, WHERE, WHEN, WHY, and HOW at the beginning. Write a headline that tells the story in a few words. (Don't insist too much on correct writing style. If the boys enjoy writing, encourage them!)
4. **Set up Pages:** Set the words in columns, if you wish. Most papers use a column format.
5. **Put it together:** Begin to paste up the paper with articles and illustrations. Use glue stick or clear tape to hold in place.

**Print your newspaper:** Make one photocopy. If it looks good, make as many copies as needed. If dark lines show, use liquid correction fluid to cover. Make photocopies from corrected version. Deliver the newspaper to readers. (Have enough copies made for each boy in the pack. Some copying companies will give Scouters a discount. Others will give you a discount if you make at least 1000 copies, which is not difficult to do with the pack bulletin.

#### **"The Morning Times"**

Greater St. Louis Area Council

Have a basket full of words that you have cut out of the newspaper. Hand out a piece of 8 1/2" X 11" paper to each boy as well as a roll of scotch tape. By picking words out of the basket, each little editor combines words to create his own newspaper headline. Write a short story based on your "Headline."

# CUB SCOUTS SPREAD THE NEWS

## January 2005

### A-Hunting You Will Go!

Greater St. Louis Area Council

Without careful observation, it is hard to notice the many different things in the newspaper. Nick Knohital-"Cub Reporter-amazes his friends with his ability to find lots of hidden things written in the paper. Let's see how well you do!

Use the newspaper to find words for each category and letter listed on the chart below. When you find a word that starts with one of the letters and also fits in a category, cut it out; the glue it in the appropriate box.

	Person's Name	Plural Word	Business Name	City or Country Name
N				
E				
W				
S				
P				
A				
P				
E				
R				

### Stop The Presses Newspaper Slide

Greater St. Louis Area Council

Shrink-It kits can be found in craft stores. This slide uses Shrink-It.

#### Materials:

Newspaper story	Cardboard
Clear plastic	Glue
Pipe cleaner	

Shrink a story from the newspaper to size you want.  
 Glue it on cardboard and cover both sides with clear plastic.  
 Glue pipe cleaner on back.

# CUB SCOUTS SPREAD THE NEWS

## January 2005

### Den Activities

#### Internet Scout Patch - Earn It!

U.S. Scouting Service Project

*This is an educational program of the U.S. Scouting Service Project and is not part of the advancement program of any WOSM Scouting Association*



#### Cub Scout (Under 11 years old) Requirements:

Do ANY 8 of Requirements 1 through 11 AND Do Requirement 12

Online help - <http://usscouts.org/internetscoutpatch-earnit.asp>.

*(You can find the Boy Scout (over 11 years old) requirements here)*

- 1. Computer Access** Find out where computing resources are available in your community or school OR visit a store where computer hardware, software and accessories are sold. Share with your leader (or a parent) and with your Den what you learned.
- 2. Getting Connected** Find out what internet service you use at home, or your parents use at work or learn about a service that is available in your home town. Discuss with your parents and Den Leader what you learned.
- 3. Online Safety** Learn about Online safety and how to protect yourself on the Internet. With your parents, guardian, or Scout Leader, go to [http://www.netSMARTZ.org/KIDS/index\\_hasFlash.html](http://www.netSMARTZ.org/KIDS/index_hasFlash.html) and complete each lesson.
- 4. Web Browsers** Explain what a browser (for example; Netscape Navigator, Microsoft Internet Explorer, Opera, Amaya, or Lynx) is and how use a browser to find information on the World Wide Web.
- 5. Using the World Wide Web** Demonstrate how to connect to the Internet and World Wide Web using a computer & modem or other device (Cable Modems, DSL, etc) . Once connected: Explain the difference between a web page and a website. Demonstrate what a "link" is and how it works. Explain how to change from one URL to another.
- 6. Searching for Information** Use a search engine on the World Wide Web Examples of search engines include; Google (<http://www.google.com>), Yahoo (<http://www.yahoo.com>), AltaVista (<http://www.altavista.digital.com>), Lycos (<http://www.lycos.com>) and FirstGov (<http://firstgov.gov>). Find a website which addresses some part of Scouting.
- 7. Using the Web for Scouting** Visit <http://macscouter.com/CubScouts/CubCmptr/index.html> and under the category "Let's Go Surfing", find and print out games, songs or skits. (If Bears find a game, song or skit they like and get their Den Leader's approval, they can plan and conduct one of the above during a den meeting and complete Achievement 24c.)
- 8. Your Own Web Page** With the help of an adult build a simple web page and show it to your Scout Leader (or a parent). This web page should include text, a link, and a graphic. (note: This web page does not have to be put on the internet to qualify and can be done as a den project.) Discuss with your Scout leader (or a parent) how an individual with disabilities can access the web.
- 9. Using E-mail** Show how to send and receive e-mail.
- 10. Internet Communications** Explain what Messenger-type services (AOL Instant Messenger, MSN Messenger, Yahoo Messenger, etc.) are and how to use them. Explain to an Adult what to do when somebody you don't know tries to chat with you. Explain what to do when somebody tries to find out where you live or go to school. With an adult present, use one of these tools.
- 11. Safe Computing** Explain what a computer virus and worm are. Explain how to protect your computer from viruses, worms, and other malicious programs.
- 12. Downloading Software** Explain to your Scout Leader what can go wrong with your computer when you download software and how to safely download software. If you have a home computer, discuss with your parents what software you can download on your home computer.

# CUB SCOUTS SPREAD THE NEWS

## January 2005

### Den Activities

Boys' Life Reading Contest



Enter the *Boys' Life* Reading Contest Now!

Write a one-page report titled "The Best Book I Read This Year" and enter it in the *Boys' Life* 2003 "Say Yes to Reading!" contest.

The book can be fiction or nonfiction. But the report has to be in your own words—500 words tops. Enter in one of these three age categories: 8 years old and younger, 9 and 10 years old, or 11 years and older.

First-place winners in each age category will receive a \$100 gift certificate good for any product in the Boy Scouts Official Retail Catalog. Second-place will receive a \$75 gift certificate, and third-place a \$50 certificate.

Everyone who enters will get a free patch like the square one above. (The patch is a temporary insignia, so it can be worn on the Boy Scout uniform shirt. Proudly display it there or anywhere!) In coming years, you'll have the opportunity to earn the other patches.

The contest is open to all *Boys' Life* readers. Be sure to include your name, address, age and grade on the entry.

Send your report, along with a business-size, self-addressed, stamped envelope, to:

*Boys' Life* Reading Contest, S306  
P.O. Box 152079  
Irving, TX 75015-2079

For more details go to [www.boyslife.org](http://www.boyslife.org)

Entries must be postmarked by Dec. 31 of the year they are submitted

### Paper cup Telephones

National Capital Area Council

Make a small hole in the base of each cup. Insert one string from the outside to the inside of each set of cups and secure it with a piece of tape. Let the Cub and his partner talk to each other. Be sure to keep the string taut but don't pull so hard that the string comes untaped. Suggest they have a code word to indicate they are done talking, so each knows when to change from listening mode to speaking mode.

# CUB SCOUTS SPREAD THE NEWS

## January 2005

### Den Activities

#### Telephone Den Meeting

Sam Houston Area Council

Practice your phone skills by holding the meeting over the phone. Set up a telephone schedule the previous week with the time that each boy is to call another. Give each boy a message to give to the others a week ahead of time. Put it in a sealed envelope and put them on their honor to open it only on the day of the calls.

On the day of the stay-home meeting, the boys should open their envelopes and keep their calling schedule. They should write down the messages that you gave them to share with one another. Have them bring the messages with them to the next den meeting. Compare the messages that the boys wrote down with the messages you gave them. Discuss how communication breaks down and how they can make it better.

:00 Boy 1 calls boy 5  
Boy 2 calls boy 6  
Boy 3 calls boy 7  
Boy 4 calls boy 8

:05 Boy 5 calls boy 2  
Boy 6 calls boy 3  
Boy 7 calls boy 4  
Boy 8 calls boy 1

:10 Boy 1 calls boy 6  
Boy 2 calls boy 7  
Boy 3 calls boy 8  
Boy 4 calls boy 5

:15 Boy 5 calls boy 3  
Boy 6 calls boy 4  
Boy 7 calls boy 1  
Boy 8 calls boy 2

:20 Boy 1 calls boy 2  
Boy 3 calls boy 4  
Boy 5 calls boy 6  
Boy 7 calls boy 8

:25 Boy 2 calls boy 3  
Boy 4 calls boy 1  
Boy 6 calls boy 7  
Boy 8 calls boy 5

:30 Boy 1 calls boy 3  
Boy 4 calls boy 2  
Boy 5 calls boy 7  
Boy 8 calls boy 6

:35 Boy 1 calls Den Leader

:38 Boy 2 calls Den Leader

:41 Boy 3 calls Den Leader

:44 Boy 4 calls Den Leader

:47 Boy 5 calls Den Leader

:50 Boy 6 calls Den Leader

:53 Boy 7 calls Den Leader

:56 Boy 8 calls Den Leader

***Stay on time!***

***If a boy is missing or you do not have eight boys, give byes to those who have no one to call.***

# CUB SCOUTS SPREAD THE NEWS

## January 2005

### Crafts

#### **FINGER PAINT RECIPE**

reprinted with permission from Sarah. Visit her site that has more fun recipes

<http://www.cp.duluth.mn.us/~sarah/rdr010.html#anchor229016>

1/4 cup cornstarch

2 cups water

food coloring

Mix ingredients in saucepan. Boil until mixture thickens. Allow to cool, then pour into jars or other storage containers and color with food coloring. Best used on a glossy paper, such as butcher or shelf paper.

#### **Make a Pillow**

Chris Reisel, Baloo

One summer, when our son went away to Webelos camp I made him a pillow while he was gone.

This idea, I believe, is a fun easy craft for adults to do with all those scouting T-shirts our boys grow out of.

Yet it will give the boys a lasting memory of their Tiger or Cubbing days.

Just to let you know though, I bought a small (sz 5) T-shirt to do this.

Take an old Scout Class B shirt or day camp shirt or ...

Sew the bottom and the sleeves (near the bottom of them) closed.

Get poly fiberfill and stuff the T-shirt

Hand stitch the neck of the T-Shirt close.

Voila, a quick easy pillow. This pillow isn't really for sleeping. It is used as a room/bed accessory.

#### **DEN NEWSLETTER**

The den's newsletter can be whatever the boys want to make it. Ask each boy to write at least one story for the paper.

Here are a few possible topics:

- A report on a recent den field trip.

- Brief impression of a recent den or pack event.

- Directions for playing the writer's favorite game.

- A report on an interview with the den leader.

- A one- or two-paragraph description of each den member written by himself.

- An interview with the den chief, who tells why he likes Boy Scouting.

- A story on what the den plans to do for the Blue and Gold Banquet.

If you have an artist in the den, he may want to draw a cartoon or some other illustration. A boy interested in photography might choose to take photos of den activities.

Recruit boys and parents who have access to a computer to help produce some or all of the newsletter electronically using graphics and word processing programs.



# CUB SCOUTS SPREAD THE NEWS

## January 2005

### Crafts

#### **Printing**

You can make designs and use them over and over to make greeting cards, gift wrapping, banquet programs and menus and stationary. Cover the table where you are working with newspapers because you must press down hard when printing to make a clear print. Design will print the reverse of what is seen on the block so if there is lettering or a design that has a right or left, it should be glued to the block backwards.

#### **Potato Printing**

- ✓ Potatoes make good block prints, if used right away. They are easily carved, but last only a day or two. One potato makes at least two designs.
- ✓ Select a good bold design, free of small designs.
- ✓ Cut potato in half with one straight cut and blot the surface to removed as much moisture as possible.
- ✓ With an orange stick or pencil, trace design on potato.
- ✓ Cut away all parts without any design ont hem. Cut outline at least 1/3" deep to provide a good printing surface. • Again remove additional moisture.
- ✓ Place paper to be printed on a pad of newspaper or a water-soluble printer's ink on design.
- ✓ Transfer potato design onto paper. Press had but do not move the potato or the design will smudge.

#### **Leaf Printing**

Trees shrubs, flowering plants and weeks offer an infinite source of leaf designs for printing. Use an inked stamp pad, place leaf, veins side down on pad. Lay a piece of newspaper over leaf and rub fingers over it. Remove leaf and place it on surface to be printed. Pace clean newspaper on tap and rub.

#### **Crayon Rubbing**

Place leaves veins side up on paper or textured surface, such as burlap, wood or leatherette. Cover with sheet of plain paper and rub crayon held sideways. Outlines and veining of leaves will stand out.

#### **Printing With Sponges**

On a dry plastic sponge draw or trace your design. Cut cleanly along the lines. Place poster paint in a dish, brush the paint onto the flat part of the sponge and stamp it on your paper.

#### **Printing With Erasers**

Draw your design on a gum eraser. Use a craft knife or scissors to cut away the part around the design so the pattern is raised.

#### **Printing With Odds And Ends**

Interesting and easy prints can be made with odds and ends from around the house. You will be surprised with the patterns you can make by pressing the bottom of a spice can or a bottle on an ink pad and then stamping your paper. Other things such as:

Matchbox  
Buttons  
Fork

Half an Onion  
Coins  
Toothbrush

Your hand  
Kitchen Utensils

# CUB SCOUTS SPREAD THE NEWS

## January 2005

### Crafts

#### MEMO HOLDERS

##### CRAFT STICK

Materials: One large craft stick (tongue depressor); 1 spring-type clothes pin; Markers; Glue; Strip magnet.

Glue a clothespin near the end of the craft stick. Decorate with markers. Attach magnet.

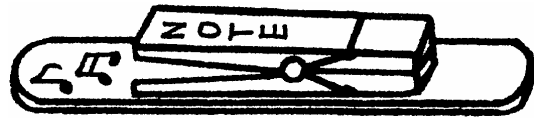

with

##### PAINT STICK

Materials: One paint stick (for quart or gallon can, about 14" long); Several spring-type clothes pins, Paint; Permanent markers; Glue; Strip magnet.

Paint the paint stick. Use any wood paint or acrylic paint.

Attach clothespins. If desired, decorate the clothespins glue them on the paint stick. Decorate with markers. Attach magnet strips on the paint stick.

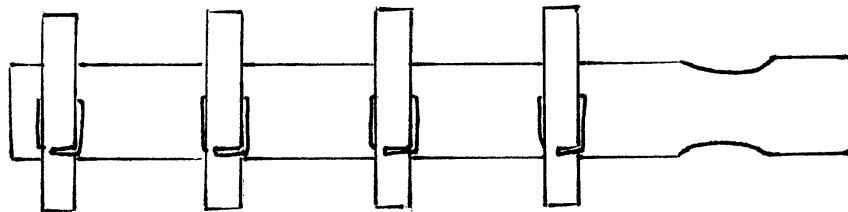

paint or before you

back of the

##### LETTER OPENER

Materials: One craft stick (tongue depressor); Sandpaper; Yarn; Raffia; Twine; lacing; Small piece of cardboard; Permanent marker; Shellac (optional).

Sand one end to a point--not too sharp! Sand both edges until they are angled and enough for opening letters. Sand as illustrated. (It's easier if you move the craft stick sandpaper than the other way.)

Wrap the handle end with yarn, raffia, twine, plastic other material. Wrap about an inch and end. Put a dab of glue on each end to unraveling.

Fold the cardboard, draw a small, simple design. Cut both layers. Glue them over the handle, one on each side of the stick.

Draw design on the stick with markers.

Finish with a coat of shellac (adult assistance necessary).

view from the end

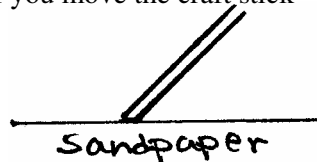

Plastic

smooth over

lacing, or fasten the prevent

top of the

# CUB SCOUTS SPREAD THE NEWS

## January 2005

### Crafts

#### RUSTIC LETTER HOLDER

Material: Two good sized log slices about 1" thick; Felt piece; Saw; Glue.

Sand the surface of wood pieces well.

Use one for the base. Glue a piece of felt to the bottom.

Saw the other piece in half and glue the straight edges of these halves across leaving space between for letters.

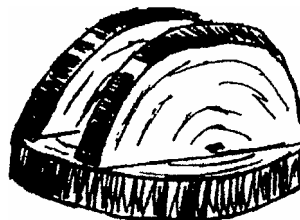

the base,

#### PAPER CLIP PALS AND PUSHPIN PALS

Materials:

Large paper clips (2") or Pushpins (the larger the better, but regular ones work fine)

Thin wood shapes (Woodsies, available at craft stores) or Craft foam shapes. Wood shapes work better if you are using regular size pushpins. On the other hand, craft foam is easier to cut with scissors. You may want to combine them too.

Permanent markers (Sharpies), regular tipped and fine-tipped.

Wiggle eyes (optional).

Glue: Tacky glue or white glue AND Glue gun with low temp glue sticks

Toothpicks.

Arrange pieces to your liking. (Children have great imaginations. Provide them with various shapes and let them go to work.) Keep your design simple. In the examples below, to make the bill of the cap, glue a small piece of foam or draw with marker.

If you are using wood shapes, color them with permanent markers--less messy and faster to dry than regular paint.

Optionally you can color the assembled pieces later.

Glue pieces together. Use tacky glue and toothpicks rather than glue gun.

Add details with markers.

Using a glue gun, attach your creation on a pushpin or paper clip.

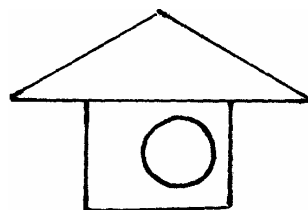
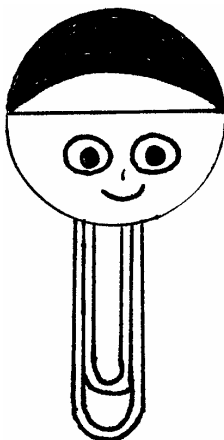
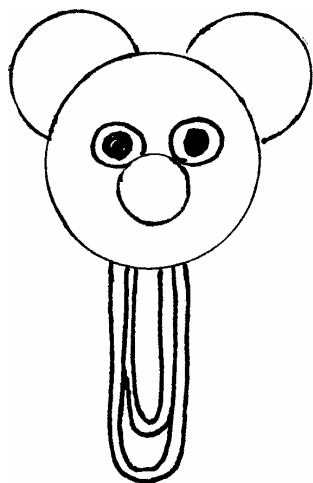

# CUB SCOUTS SPREAD THE NEWS

## January 2005

### Skits

#### PREPARING YOUR SKIT

National Capital Area Council

Skits are another form of communication. They're usually a dramatized joke or funny situation with a snappy line or sight gag at the end. Skits help channel a boy's imagination. He doesn't just play he's a pirate -- he **IS** a pirate, sailing the ocean blue under the Jolly Roger. Dramatics are important in the growth of a boy because it gives him an outlet for the "let's pretend" part of his character. It gives him a chance for creative expression. Skits help develop his power of observation and recognize the desirable characteristics in the people he sees. Skits help develop his coordination and timing, thus increasing his self-confidence. Skits show the importance of teamwork and cooperation.

Skits also set the mood of the monthly theme. Skits serve as icebreakers and comic relief during the pack meeting.

Skits take the pack meeting out of the hands of adults and focuses on the boys.

Once in a while there is a shy boy who would prefer not to take part in skits. A costume often will help overcome his shyness. He can also handle other important roles like lighting, scenery or sound effects.

If a boy is having trouble remembering his lines, write them down on index cards or use cue cards (poster board size).

#### Keep It Simple

Simple lines, simple costumes, and simple props are more effective than elaborate ones done poorly. A sign can do wonders, it turns a box into a wagon, boat, plane, etc. It can even turn a boy into a tree or a mountain.

#### Basic Elements Of A Good Skit

Good skits....

Are short (3 to 5 minutes)

Have simple dialogue ... no long memorized lines

Can use pantomimes

Let every boy participate

Have liberal usage of stage direction ... who goes where, when and does what

#### Volume

Boys must speak loudly, slowly and face the audience. If the audience applauds or laughs, Scouts should pause before continuing.

You can pre-record all the sound effects, dialogue, music, etc. and play it back on a tape recorder. The advantage is that they can be heard. A disadvantage is that you can't react to the audience and if anything goes wrong, you'll have to ad-lib. Lip syncing takes lots of practice.

#### Scenery

Scenery can be made from corrugated cardboard, sheets or props you have in the house. Use latex or tempera paints to decorate as needed. Alternatively, you can just explain to the audience beforehand, "Here is the bedroom..." and so forth. Use the power of suggestion!

# CUB SCOUTS SPREAD THE NEWS

## January 2005

### Skits

#### PREPARING YOUR SKIT (CONTINUED)

##### Make-Up

Make-up helps the audience identify the character and makes them more real.

1. Make-up base can be made with equal parts of liquid cleansing cream and powdered sugar. This is a simple white base for clown make-up. Add food coloring for monster make-up (green) or Indian paint (red, yellow and blue).
2. An eyebrow pencil can be used to darken or change the shape of eyebrows, to line the eyes, to make freckles, moustaches, sideburns, beards, and wrinkles.
3. Beards can be made with coffee grounds applied over a layer of Vaseline or cold cream.
4. Cornstarch powder or talcum powder in the hair makes characters look older. Hair usually begins to gray at the temples first.
5. A wig can be made by pulling an old stocking down over your hair and ears. Tie it off and cut off the excess. Use scotch tape to fasten colored cotton balls all over the stocking.
6. Indian braids can be made by cutting 3 strips of crepe paper into lengths about 3/4" wide. Twist each strip around the other. Now braid the 3 strips together.
7. Wounds can be made by drawing them with lipstick. Blend it in slightly with your finger. Edge the wound with white liner.
8. For shoulder padding, make small triangular cushions and insert them under the shirt with the points toward the neck. Cushions are made from scrap cloth stuffed with rags or foam.
9. Nose putty is often needed to make lumps, creepy hands, etc. Mix together 2 teaspoons white vegetable shortening, 5 teaspoons cornstarch, 1 teaspoon white flour, a few drops of glycerin, and food coloring. For a brown color add 2 teaspoons cocoa.

##### Role Playing

Help each boy bring his character to life. Add makeup to age him; use a wig to disguise him; to walk with a limp, place a small rounded rock in his shoe; to look old, have him walk with his feet about 8 inches apart.

##### Sound Effects

If you plan to use sound effects in your skit, it is important to have access to a microphone. Check with the facility where you are holding your pack meetings. Most rental stores carry karaoke sound machines. Also, you can pre-record your sounds on an audio cassette and play them back when needed.

Try some of the following techniques to add sound to your skit:

**Airplane:** Heavy paper striking blades of electric fan

**Auto brakes:** Slide a drinking glass across a pane of glass

**Crashes:** Drop two pie pans taped together with metal jar lids inside.

**Crickets chirping:** Run a fingernail over a fine-tooth comb

**Door slam:** Slam two hardback books together

**Fire:** Crumple and twist cellophane into a ball and then release it.

**Gong:** Hit a pan with a metal spoon.

**Gurgling stream or boiling liquid:** Put a straw in a cup of water and blow hard.

**Hail:** Pour rice on an upside down flat cake pan.

**Horse hooves:** Alternately tap two inverted cups or bowls on a wood floor or board.

**Knock at door:** Hit a half-gallon plastic milk jug on the end with a rubber spatula.

**Rain:** Fill a soup can 1/3-full of dry peas or beans. Roll the can slowly on a table.

**Rustling in underbrush:** Crush broom straw.

**Sword fight:** Hold an aluminum cookie sheet in one hand, & hit with a metal spoon.

**Telephone ring:** Use a bicycle bell.

**Thunder:** Grasp a metal cookie sheet on one end, placing your thumb on the underside. Shake the cookie sheet so it vibrates. Bang it against the knee for an occasional loud thunderclap.

# CUB SCOUTS SPREAD THE NEWS

## January 2005

### Skits

#### PREPARING YOUR SKIT

##### Writing Your Own Skit

Writing your own skits is simpler than it would first appear. First, determine what the moral of the skit will be. Then follow this simple outline to write your skit.

Boy wants something ... friendship, a gold mine, a trophy, to find something

Boy goes to get it ... by canoe, plane, horseback, foot

Obstacles stop boy ... crocodile, native hunters, a locked chest

Boy achieves goal ... through an act of kindness, bravery, wisdom, magic, unexpected help of some kind.

Write your skit to be 7 to 10 minutes long. The boys will shorten the skit when they present it.

##### Roving Reporter (Skit)

Sam Houston Area Council

**Reporter:** Good evening, ladies and gentlemen. Here's your roving reporter with another man-on-the-street interview. Tonight we are going to talk about mountains. Here's a man right here. How do you do, sir, can you tell me what is your impression of mountains?

**First Man:** "High!"

**Reporter:** Hi, yourself! Now tell me, what is your impression of mountains?

**First Man:** Just like I said "High!"

**Reporter:** Oh! Ha, ha, ha. My mistake. When you said "High!", I thought you said "Hi!" get it? Oh well, let's talk to someone else. Here's a man. Tell me, sir, how do you feel about mountains?

**Second Man:** Well, I've never been there, of course, but if I had to feel about mountains, I'd do like always, feel with my fingers.

**Reporter:** Ha, ha, ha, ha. Seems we have some jokesters about today. Well now, let's try our question on this little boy here. Tell me, sonny, have you ever gone over the top of a mountain?

**Small Boy:** Yes, sir, lots of times.

**Reporter:** My, I'm surprised to hear that, must have been a hard trip for a youngster, actually to go clear over the top of a mountain.

**Small Boy:** Oh! No, sir, we were in an airplane.

**Reporter:** (to himself) This is getting ridiculous, but I'll try one more time. How do you do, sir, May I ask you a question?

**Third Man:** Why sure, what's your Problem?

**Reporter:** Tell me, sir, what's your impression of life in the mountains?

**Third Man:** Well, from what I hear, it's a lot like an umbrella.

**Reporter:** An umbrella? I don't quite understand what you mean.

**Third Man:** Yup, like an umbrella. Life in the mountains is either up or down.

**Reporter:** Sorry, folks, some days you can't win.

# CUB SCOUTS SPREAD THE NEWS

## January 2005

### Skits

#### PAINTING

Santa Clara County Council

**Cub #1:** You know the den leader's birthday is coming up.

**Cub #2:** Yeah. We should do something for her.

**Cub #3:** Yeah. She's so much fun. Let's give her a present.

**Cub #4:** I don't have any money. Do you?

**Cub #5:** No. But we could earn some money.

**Cub #1:** Good idea! Let's go ask Mr. Smith. He's real nice.

*(Boys walk up to house and knock on door)*

**Cub #1:** Hi, Mr. Smith. We are trying to earn money to buy a present for our den leader.

**Cub #2:** Do you have any jobs we could do to earn extra money?

**Mr. Smith:** Why, you boys came at just the right time! I was just about to go around back and paint my porch. Do you think you can handle a job like that?

**All:** Sure!

**Mr. Smith:** OK, then. You'll find everything you need around back. Just knock on the front door if you have any questions.

**All:** Thanks, Mr. Smith!

*(Boys walk backstage behind house. They return one at a time at ask questions then walk back)*

**Cub #1:** (Knocks on door) Is this the paint you wanted us to use, Mr. Smith?

**Mr. Smith:** Yes, that's right. Thanks for checking with me.

**Cub #2:** (Knocks on door) We saw these old shirts in your garage, Mr. Smith. Is it OK if we wear them so we won't get paint on our uniforms?

**Mr. Smith:** Good idea! Glad to see you boys take such pride in your uniforms.

**Cub #3:** (Knocks on door) Mr. Smith, do you have some newspaper we could spread out in case we drip paint?

**Mr. Smith:** Sure--here you go! You boys certainly are being careful.

**Cub #4:** (Knocks on door) Is it OK if we close the windows so we don't splatter paint inside?

**Mr. Smith:** Sure--go ahead. You boys think of everything!

**Cub #5:** (Knocks on door) Did you want us to paint the door, too, Mr. Smith?

**Mr. Smith:** Sure--the door could use a fresh coat of paint!

*(Boys all return together to knock on door)*

**Cub #3:** We're all done now, Mr. Smith.

**Cub #4:** Would you like to come around back and see how we did?

**Mr. Smith:** Oh no, that won't be necessary. I know you Cub Scouts always do your best! Here's some money for each of you for your hard work

**All:** Wow! Thanks, Mr. Smith!

*(Boys begin to walk away, then one turns back)*

**Cub #5:** Thanks again Mr. Smith. Oh, and by the way. You don't have a "Porche." You have a Ferrari!

# CUB SCOUTS SPREAD THE NEWS

## January 2005

### Skits

#### SECOND LANGUAGE

##### **Arrangement:**

One den member wears a sign reading "Mother Mouse."

Another has a sign reading "Cat."

All others wear signs reading "Mouse."

(Mother mouse is taking her children for a walk)

Mother Mouse: Come children it's a beautiful day for a nice walk...

(Other mice respond. All making small talk while crossing the stage.)

(Suddenly Cat jumps into the path in front of the mice)

Mother Mouse: (in a loud voice) Bow wow wow! Bow wow wow!

(The cat screeches in fear and runs off.)

Mice: Oh, Mother, we were so scared!

Mother Mouse: Let that be a lesson to you, children. It pays to learn a second language.

#### LISTEN AT THE WALL

*Cub #1 walks along a wall just listening, listening. Others come along and see him.*

Cub #2: What do you hear?

Cub #1: (Dramatically) Listen!

*Others listen. But they don't seem to hear anything.*

Cub #3: I don't hear anything!

Cub #1: (More dramatically) Listen!

*Others listen*

Cub #4: (In a disgusted voice) I don't hear anything.

Cub #1: (With a faraway look) You know, it's been that way all day.



# CUB SCOUTS SPREAD THE NEWS

## January 2005

### Games

#### **Ring the Antenna**

Will Rogers Council

Cut out the shape of a radio or TV antenna (or if no one remembers what a house antenna looks like – a tower as seen at the station or any shape consistent with theme (or any theme, for that matter) that the boys want to use) from cardboard or wood. Paint and decorate the cut-out. Hammer nails into the shape at different places. This is the target. Place it about 8 to 10 feet away. Have each player throw rubber rings at the target. The winner is determined by the number of rings that catch on the target. If you wish, you can mark each nail worth a certain number of points.

#### **Sausages**

Will Rogers Council

One player is chosen to be the questioner. He may ask any other of the other players whatever personal questions he might choose, such as - "What do you think your legs look like?", "What are your shoes made of?", "To what do you attribute your handsome looks and charm?", etc. Whatever the question, the player being asked must reply "sausages!" The first player who smiles or laughs or giggles or smirks or grins or guffaws or shows any other emotion other than deadly seriousness is out, and he becomes the questioner.

#### **Capture the Fort**

Buckskin Council

Divide players into two sides: Attackers and Defenders.

Defenders form a circle, holding hands and facing outward, with their captain in the center.

Attackers surround the fort at about eight or ten paces distant. They try to kick a soccer ball into the fort; it may go through the legs of the defenders or over their heads. If it goes over their heads, the captain may catch it and throw it out. But if it touches the ground inside the circle, the fort is captured and the players change sides.

#### **Line up the Lines**

National Capital Area Council

Take the Promise (or the Law of the Pack) and write it out on strips of paper in large letters. If you want, you can cut the lines up into chunks or half-lines. Then have a team challenge for the whole group. Mix up the strips on the floor or in a box. One by one, a Cub hops to the box, grabs a strip, and brings it back to the group. The next Cub hops up and gets another strip and brings it back to the group. Hopping is done to give the group time to arrange the strips in order. The group has to agree on how to arrange the strips. When done, they recite the Promise together.

#### **Gossip Game**

National Capital Area Council

Have everyone sit in a large circle. The host partner whispers a phrase or short sentence to the person on his left. That person whispers what he heard to the next player to the left, and so on. The last player to receive the message should repeat what the message is. The leader then repeats the original message which is often very different from the last person's message.

# CUB SCOUTS SPREAD THE NEWS

## January 2005

### Games

#### **Hear, Bear Game**

Sam Houston Council

This is a game of identifying sounds. The den chief produces the sounds below from behind a screen or in another room and the Cubs listen. As each sound is produced, the boys write down what they think it is. Sample sounds are: Sandpaper rubbed on glass, Pack of cards dropped on a table, Egg whipper whipping cream, Golf ball or ping-pong ball bouncing on a bare floor, Piece of metal being filed, Slicing bread, Cutting glass with a glass cutter, Bursting a paper bag.

#### **Mysterious Message**

Baloo

Mysteries sometimes include coded messages. Let your Cubs create a code, write coded messages and then decode each other's messages. Leaders if you have access to a computer and printer you can use wing dings (font) or let the Cubs develop their own secret code using the alphabet.

**Materials:** Paper and pencils

Write the alphabet across a chalkboard.

Below the letters write the numbers 1-26, with "1" below "A," "2" below "B," etc.

Then write a simple, short sentence on the board and write the number equivalent of the first word.

Ask your Cubs to write the number equivalents of the remaining words.

Challenge each den group to make up a code based on a growing number pattern (e.g., 1, 2, 4, 7, 11 . . .).

On a sheet of paper, have Cubs write the alphabet and the number that will stand for each letter, just as you did on the board.

Now have the Cubs write a secret message (a short sentence) and encode the message on another sheet of paper.

#### **Moriarty**

Sam Houston Area Council

One Cub is secretly chosen to be Moriarty, the rest are English detectives. Everyone walks around shaking hands, introducing themselves and making small talk. A victim is killed when Moriarty tickles his palm during the handshake. The victim must wait at least 5 seconds before dying in as dramatic manner as possible; he may even have time to shake another hand in the interval. The object of the game is to discover Moriarty and publicly accuse him before being killed. If the accuser is discovered, he picks the next Moriarty and participates in the next game by shaking hands, etc. He cannot make an accusation but acts as referee since he knows who Moriarty is.

# CUB SCOUTS SPREAD THE NEWS

## January 2005

### Advancement Ceremonies

#### Reporter Award Ceremony

Santa Clara Council

Cubmaster comes out wearing a 30's style hat with the brim turned up and a "press card" tucked into the hatband.

**Cubmaster:** I'm hot on the trail of a story. I just need to find the right person to interview. Let's see! Can I interview you? (Pointing to a den leader.)

**Den Leader:** Yes, you can interview me.

**Cubmaster:** Tell me, what you have been doing this month.

**Den Leader:** Well, we have been learning about newspapers. We made our own paper.

**Cubmaster:** Oh, really! What else have you been doing?

**Den Leader:** All the boys in the den completed requirements for the\_\_ badge.

**Cubmaster:** Super, will \_\_\_\_\_ step up with their parents and receive their awards?

#### Advancement Ceremony

Simon Kenton Council

For the ceremony to induct new Bobcats, the Cubmaster writes on a blackboard or butcher paper the code: "YLIMAF ELOHW EHT ROF -- GNITUOCS BUC.: (Cub Scouting—for the whole family, written backwards. The Cubmaster should then call forward those boys to receive Bobcat and their parents. Ask the boys whether they can read the code. When they have figured it out, then speak briefly on the parents' role in the program. Award Bobcat badge and certificates.

For awarding Wolf and Bear badges, Arrow points, and Webelos awards have the Cubmaster act as emcee of an awards show, announcing names of the advancing boys and explaining their achievements, while the boys and their parents receive the badge from a pack committee member. On all the boys names could be written a secret code (mixed-up order) and as they are called forward to receive the award, they must figure out where their name is and their parents receive the badge from a pack committee member. All the boys' names could be written in secret code (mixed up order) and they are called forward to receive award, they must figure out where their name is.

#### ADVANCEMENT IDEAS

Santa Clara County Council

- ✓ Use a secret code in the ceremony. Names of the boys receiving awards or their rank may be written in secret code.
- ✓ Use message written in invisible ink. Use a candle to make the message appear (light bulb takes too long. Message should be short and written big so the audience can see it. Practice ahead of time. For suggestions for the "ink," see the "Crafts" section for this month.
- ✓ Pack advancement chair may be "radio announcer" who calls the boys up before the Cubmaster with appropriate announcement and calls for applause.
- ✓ Cubmaster talks in Pig Latin. Assistant Cubmaster introduces Cubmaster as a guest from a far-away nation of Cubland. He says that this guest will give awards this month. Cubmaster talks slowly and the assistant repeats in "normal" English. Let the boys catch on. (Pig Latin is listed in the "Games" section of this month.)

# CUB SCOUTS SPREAD THE NEWS

## January 2005

### Advancement Ceremonies

#### REPORTER ADVANCEMENT

**Setting:** TV News Anchor desk (table) with Anchorman seated. Camera can be added off on the side taping the presentation.

#### **Anchorman (Cubmaster):**

Good evening and welcome to tonight's broadcast of Channel (pack number), CUB Evening News. I am your newscaster, T.L.Meanething (pronounced "tell me anything"). We have exciting news this evening. We have learned that there are several awards to be presented. Will the following boys and their parents please come forward? (Call forward Cub Scouts receiving Bobcat, Wolf, Bear and Webelos badges)

You have just finished journalism school and like the Bobcat, you have taken your first step towards an exciting career. I encourage you to continue going forward in your endeavors.

The next awards go to our Cub Reporters, the Wolves. They are learning the trade of reporting. Though they still have a long way to go, they've made a great start.

Our next awards go to our Ace Reporters, the Bears. These guys know how to find and tell stories of interest, but still need help along the way.

Finally, these awards are for our Editors, the Webelos. These young men have learned not only how to find and report good stories, but also what it takes to make these stories exciting and different. As all good Editors, they are always preparing themselves for the next big assignment.

Congratulations to you all.

That's all the news we have for you in tonight's program. Thank you for tuning in. This is T.L.Meanething signing off.

#### FUN WAYS TO SAY THANK YOU

First Class envelope: "You did a first class job!"

Newspaper: "Thanks a bundle!"

Pencil: "You're sharp and to the point!"

Toy telephone or two tin cans connected by a string:

For keeping everyone informed of changes.

For someone who coordinates the pack phone tree.

# CUB SCOUTS SPREAD THE NEWS

## January 2005

### SONGS

#### Call A Scout

(Tune: If You're Happy and You Know It)

Simon Kenton Council

When you're down and feeling blue

CALL A SCOUT

They'll know just what to do

CALL A SCOUT

If you're ever in a hurry

Don't take the time to worry

All you have to do is shout

CALL A SCOUT

If you need a helping hand

CALL A SCOUT

They'll take your garbage out

CALL A SCOUT

If the traffic that you meet

Has you scared to cross the street

They'll be there to help you out

CALL A SCOUT

Now the Scouts are always helpful

Don't you see

They will lend a helping hand

To you and me

For they're wise in what they do

They are kind and cheerful too

And they always help you out

CALL A SCOUT

#### THE MORE WE COMMUNICATE

(Tune: The More We Get Together)

The more that we communicate,

Communicate, communicate,

The more that we communicate,

The happier we'll be.

Then you know what I know,

And I'll know what you know.

The more that we communicate,

The happier we'll be.

By telephone or e-mail,

By signal code or snail mail,

The more that we communicate,

The happier we'll be.

#### The Gutenberg of Old

Tune: The Grand Old Duke of York

(revised a bit--Chris)

The Gutenberg of old,

He had 10,000 books,

He stacked the **up** the shelves, (stand)

And he **knocked** them down again. (sit)

And when they're up you're **up**. (stand)

And when they're down you're **down** (sit)

And when they're only **halfway up**, (**squat**)

You're neither **up** nor **down**.

Sing three times a little faster

#### Communication

(Tune: Alouette)

Circle 10 Council

Communication, superb communication,

Communication, it's the way to go

First you take a telephone

Never say you are alone.

Be polite, never fight,

OOOohhhh,

#### Refrain:

Communication, superb communication,

Communication, it's the way to go

Next you take a short email

Start with "Dear" it never fails

Subject line, then you sign.

#### Refrain:

Last you take an envelope,

Don't forget the stamp, nope, Nope!

Mailman comes, then your done

OOOohhhh,

#### Refrain

# CUB SCOUTS SPREAD THE NEWS

## January 2005

### SONGS

#### Billboards

(Tune: Supercalifragilisticexpialidocious)

York Adams Council

As I was walking down the street one dark and gloomy day  
I came upon a billboard and much to my dismay  
The sign was torn and tattered from the storm the night before  
The wind and rain had done it's work and this it what I saw:  
Kennel Ration Dog Food keeps your wife's complexion clear  
Simonize your baby with a Hershey's candy bar --  
And Texaco's the beauty cream that's used by all the stars!"  
"So take your next vacation in a brand new Fridgidaire --  
Learn to play piano in your winter underwear --  
Doctors say that babies should smoke until they are three  
And people over 65 should bathe in Lipton Tea!" (slowly)...in flow-thru tea bags

#### Commercial Mix-Up

(Tune: Farmer in the Dell)  
York Adams Area Council)

Last night I watched TV, I saw my favorite show  
I heard this strange commercial, and I can't believe it's so  
Feed your dog Chiffon. Comet cures the cold  
Use S-O-S pads on your face to keep from looking old.  
Mop your floors with Crest. Use Crisco on your tile  
Clean your teeth with Borateem, it leaves a shining smile  
For headaches take some Certs. Use Tide to clean your face  
And do shampoo with Elmer's Glue, it holds your hair in place  
Perhaps I am confused, I might not have it right  
But one thing that I'm certain of, I'll watch TV tonight!

#### E-MAIL DELIVERY

(Tune: She'll Be Coming Round the Mtn)

I'm sitting down in front of my computer  
Turn it on  
I'm sitting down in front of my computer  
Turn it on  
I'm sitting down by my computer  
I'm sitting down by my computer  
I'm sitting down in front of my computer  
Turn it on  
  
I'm sending you an e-mail on your line  
Type, type  
I'm sending you an e-mail on your line  
Type, type

I'm sending you an e-mail  
I'm sending you an e-mail  
I'm sending you an e-mail on your line  
Type, type

Through the information highway it will come  
Zip, zip

It's waiting in your mailbox just for you  
Delivery

Load it up so you can read it  
Loading up

Give a shout if you're a Cub Scout  
Yip hurrah!

# CUB SCOUTS SPREAD THE NEWS

## January 2005

### Run On/ Applause

#### Riddles and Jokes

Viking Council

This is an easy way to get your Den Chief or denner involved with the boys as they arrive. Everyone likes jokes and riddles. For more ideas, look in the current issue of Boys Life Magazine.

**A Pilgrim had nine ears of corn in his barn. Each day a squirrel came to the barn and went away with three ears. It took nine days to remove all the corn. Why?**

(The squirrel went away with three ears, but only one was corn. The other two were his own!)

**An Indian had 2 1/2 piles of corn in one field. He had 1 1/2 piles of corn in another field. Then he put them together. How many piles did he have?**

(One)

**What kind of music did the Pilgrims dance to?**

(The Plymouth Rock).

#### Run-Ons

Gulf Coast Council

**Scout 1 (picking up phone):** "You don't say... You don't say... You don't say..."

**Scout 2:** Who was that?

**Scout 1:** I don't know. He didn't say.

**Scout 1:** I have been seeing spots in front of my eyes.

**Scout 2:** Have you seen the doctor?

**Scout 1:** No, just spots.

**Scout Fortune Teller:** That will be \$20. for two questions.

**Customer:** Isn't that a lot of money for two questions?

**Scout Fortune Teller:** Yes, it is. Now what is your second question?

**Scout 1:** Why didn't you wait to see the second act of the play?

**Scout 2:** Didn't have time. The program said it took place a year later.

#### Feel the Pane

The Leader has a 'volunteer' who is going around the room, touching the wall.

"Do you feel it?" the Leader asks.

"No" replied the volunteer.

Repeatedly, the leader asks and get the same answer.

The volunteer comes to the window.

"Do you feel it now?"

"Yes, " says the volunteer (Perhaps he howls suddenly to make this more dramatic.)

"What did you feel?"

"I felt the pane."

# CUB SCOUTS SPREAD THE NEWS

## January 2005

### Run On/ Applause

#### Run Ons

**Circle 10 Council**

**Why did the email go to the doctor?**

It had a virus.

**What has 1000 ears but can't hear?**

A cornfield.

#### Knock Knock

Who's there !

**Cash !**

Cash who ?

**Cash me if you can !**

#### Knock Knock

Who's there !

**Cash !**

Cash who ?

**I knew you were nuts !**

#### Cheers

Sam Houston Area Council

**Billy Goat Cheer-** Pull on 'beard' three times. Each time you pull, yell "Baaa!"

**Eggbeater Cheer** – Bend knees and swing them in and out like beaters while putting hand on top of the head to hold handle and use other hand to turn beater crank.

**Den How Cheer** - "Strawberry shortcake, Eskimo pop, Den \_\_, Den \_\_ Always on top!"

**Seal of Approval** – Place arms together from elbows to wrists, then slap hands together while barking like a seal.

**Soul Cheer** –Announce that this cheer is for people who put their heart and soul into what they're doing. Pat the palm of one hand on the sole of your shoe and place the other over your heart. Do this three times.



# CUB SCOUTS SPREAD THE NEWS

## January 2005

### Audience Participations

#### Computer Pals

National Capital Area Council

Divide the group into seven smaller groups and assign each group one of the words listed below. Read the story. After each of the words is read pause for the group to make the appropriate response.

<b>Jeff</b>	"Whew, it's hot!"
<b>Mouse</b>	"Squeak, Squeak"
<b>Vaughn</b>	"Burrrrrrrr, it's cold!"
<b>Nome, Alaska</b>	"Watch out for the moose!"
<b>E-Mail</b>	"Zoom, Bing!"
<b>Orlando, Florida</b>	"Mickey Mouse"
<b>Send</b>	"Click, Swish!"
<b>Keyboard</b>	"Typety, typety"
<b>Scout or Scouting</b>	"Do Your Best!" (ALL)

**Vaughn** had just attended School Night for **Scouting** in his home town of **Nome, Alaska**. He wanted to **SEND E-Mail** to his computer pal **Jeff**, in **Orlando, Florida** to tell him that he joined **Scouts**. He knew that **Jeff** had been in **Scouting** for a while and wanted to find out what he was getting into.

So, **Vaughn** sat down at the computer **Keyboard** and reached for his **Mouse**. He typed in the message, hit **Send** with the **Mouse** and eagerly awaited **Jeff's** reply.

While doing homework at the **Keyboard**, **Jeff** received **Vaughn's E-Mail**. He was really excited to get **Vaughn's** news. **Jeff** immediately sent **E-Mail** back to **Vaughn** in **Nome, Alaska** with all the fun **Scouting** stuff they do in **Orlando, Florida**. He talked about such things as the Pinewood Derby, Day Camp, the Blue & Gold, the Raingutter Regatta, Orama, plus all of the great hikes, field trips and more! When **Jeff** finished listing all the things they do in **Scouts**, he hit the **Send** key on his **Keyboard**. After **Vaughn** finished reading **Jeff's E-Mail**, he began to think he had made a smart decision by joining **Scouts**.

A couple of weeks later, after **Vaughn** had attended his first Pack meeting, where he received his Bobcat badge, he decided to **Send Jeff** an **E-Mail** to tell him the good news. So he sat down at the **Keyboard** and reached for his **Mouse** to **Send** the message.

**Jeff** drew a card with his **Mouse** to congratulate **Vaughn** for earning his first **Scouting** badge.

After each of their meetings, **Jeff** from **Orlando, Florida** and **Vaughn** from **Nome, Alaska** would **Send E-Mail** to each other telling everything they had done in their meetings. They both agreed **Scouting** is a lot of fun. They also became life-long buddies and pen pals!

# CUB SCOUTS SPREAD THE NEWS

## January 2005

### Closings

#### A CUB SCOUT PLEDGE TO HIMSELF

*Arrangement: Pack flag is placed in center of stage. Ten Cubs in uniform, in turn, come on stage, stand near the Pack flag and recite one of the statements below. Upon finishing, each Scout salutes the Pack flag and retires to rear of stage, where a horseshoe is formed.*

1<sup>st</sup> Cub: May I grow in character and ability as I grow in size.

2<sup>nd</sup> Cub: May I be honest with myself and others in what I do and say.

3<sup>rd</sup> Cub: May I learn and practice my religion.

4<sup>th</sup> Cub: May I always honor my parents, my elders and my leaders.

5<sup>th</sup> Cub: May I develop high moral principles and the courage to live by them.

6<sup>th</sup> Cub: May I strive for health in body, mind and spirit.

7<sup>th</sup> Cub: May I always respect the rights of other.

8<sup>th</sup> Cub: May I set a good example so that others may enjoy and profit from my company.

9<sup>th</sup> Cub: May I give honest effort to my work.

10<sup>th</sup> Cub: May I regard my education as preparation for the future.

After all Cubs are finished with their lines, all present can join hands for the Living Circle and repeat the Cub Scout Promise.



#### MUSCLE BUILDERS

*ARRANGEMENT: The following closing ceremony leaves the audience with some good closing thoughts. Seven boys line up across the stage holding barbells which have letters printed on each end spelling out MUSCLE BUILDERS.*

1<sup>st</sup> Cub: Muscles some think are really a must, unless you want to be a bust.

2<sup>nd</sup> Cub: So flex your muscles and raise those weights high. Cause it will make a healthy guy.

3<sup>rd</sup> Cub: Lift all of the load you possibly can, else you could be called a shirking man.

4<sup>th</sup> Cub: Buckle down and lift your share of the load, unless you want to be a shirker on life's road.

5<sup>th</sup> Cub: If you always do your part, lifters you will be from the start.

6<sup>th</sup> Cub: Do your best to lift your share, everyone showing that they care.

7<sup>th</sup> Cub: Reaching always a little out of reach, since that's the best philosophy to teach.

# CUB SCOUTS SPREAD THE NEWS

## January 2005

### Closings

#### Stop The Presses Closing Ceremony

Trapper Trails Council

**Narrator:** Stop those presses. Some of the stories we've been hearing for years aren't quite right. Did you know...?

- Cub # 1.** An apple did not fall on Newton's head, he saw one fall from the corner of his eye.
  - Cub # 2.** In old England, coins were saved in "pygg" banks which were dishes or jars made from a clay called "pygg". In 1600, a potter started the craze of making them into pig shapes.
  - Cub # 3.** French fries are really from Belgium.
  - Cub # 4.** Walt Disney started drawing characters with three fingers to save time.
  - Cub # 5.** Napoleon started the tradition of buttons on uniforms so soldiers would not wipe their noses on the coat sleeves.
  - Cub # 6.** The 4 and 20 black birds baked in a pie was actually a huge pie crust with 24 African musicians hiding inside to surprise a King Charles VII of France in the 1400's.
  - Cub # 7.** Mice might eat cheese, but they like peanut butter and fly stuffed celery better.
  - Cub # 8.** Elephants are not afraid of mice, which they can't even see or smell.
  - Cub # 9.** Antidisestablishmentarianism is not the longest word, it is pneumonoultramicroscopicsilicovolcanoconiosis.
  - Cub # 10.** Ostriches don't bury their heads in the sand. They eat rocks to help their digestion.
  - Cub # 11.** The British arrested and took Paul Revere's horse before he finished his ride. He had to walk home.
  - Cub # 12.** Camels store fat not water in their humps.
- Narrator** - So stop those presses, we need to make a few changes.

#### Thank You

Viking Council

Let the Cub Scouts prepare eight large placards, each with a large letter painted on it to match the initial letter of each verse. As each verse is recited by a Cub, the proper lettis is displayed so that at the end of the eight verses, the words "Thank You" are visible to all.

- Cub # 1.** **T** - stands for teacher, ours bear the test, as a Pack - we promise "We'll do our best".
- Cub # 2.** **H** - is for helpful, which we try to be as each helps the other in the highest degree.
- Cub # 3.** **A** - for advantages we all enjoy, we try to be grateful and wisely employ.
- Cub # 4.** **N** - is for nation whose future depend, on all of us in the pack who want to be friends.
- Cub # 5.** **K** - is for knowledge we're going to need. We'll work hard to gain it and hope we succeed.
- Cub # 6.** **Y** - is for youth all over the land. God bless and keep us and steady our hand.
- Cub # 7.** **O** - for opportunity around everyone. We'll grasp and hold tightly until we have won.
- Cub # 8.** **U** - stand for usefulness, we like to serve. We do what we can all praise to deserve.

# CUB SCOUTS SPREAD THE NEWS

## January 2005

### After the Meeting

#### **FIRECRACKER**

##### *Materials Needed:*

*Twinkie (or other similar snack cake)*

*Red, White, and Blue Frosting*

*Red, Shoe String Licorice*

##### **Instructions:**

Cut a 3-4 inch length from a licorice piece. Poke one end of this piece into one of the ends of the Twinkie. This should look like the fire cracker's wick. Now, decorate the fire cracker with whatever design you like using the frosting!

#### **CRITTER CRUNCH**

Great-tasting, fun-to-eat Critter Crunch is easy enough for kids to make. They can mix it up to a month ahead of time and store it in a covered container or zippered plastic bag.

##### *Materials Needed:*

*1 C. animal crackers*

*1 C. teddy bear-shaped chocolate or  
honey-flavored graham crackers*

*1 C. miniature pretzel twists*

*1 C. yogurt-covered raisins*

*1 C. candy-coated chocolate candies*

*Colorful ice cream cones (optional)*

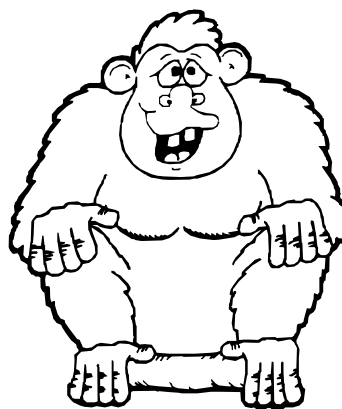

##### **Instructions:**

Mix all ingredients except ice cream cones. Store in a covered container.

Serve snack in cones if desired.

Makes 10 servings (1/2 cup each)

##### **APPLE SMILES** *Ingredients:*

*Apples*

*Peanut Butter*

*Miniature Marshmallows*

##### **Instructions:**

Cut apples into wedges. Smear peanut butter on one side of 2 wedges. Stick a few marshmallows on the peanut butter on one of the apple wedges and top with the other apple wedge - peanut butter side down. When you look at this it looks like a smile (the red part of the apple are the lips and the marshmallows are the teeth!)

#### **Fred's Trail Mix**

Fred Feltmann

Greater Alabama Council

1 Bag (large) Eagle brand Snack mix

1 16 oz. bag M&Ms

1 8 oz. bag semi-sweet mini M&Ms (cooking section of grocery store)

1 24 oz. can raisins (use as much as you think you need)

1 can mixed nuts (Adjust quantities to taste - this will get you started!)

This makes enough for a group of 6 for a weekend

# CUB SCOUTS SPREAD THE NEWS

## January 2005

### After the Meeting

#### **Cranberries?**

Viking Council

Did you know that the Pilgrims gave the cranberry its name? They thought the pink cranberry blossoms resembled the heads of cranes, so they called them "Crane berries." This was later changed slightly to "cranberries."

Look up pictures of cranes and the cranberry bogs of New England. During your den meeting, make fresh cranberry bread for your den snack.

#### **Big - Mouth Apples**

3 apples, cored -- leave skin on, cut in 8 wedges each

3/4 c. peanut butter

72 mini marshmallows

Place 12 apple wedges on your work surface. Spread 1 tbs. peanut butter on 1 side of each of the wedges. Top each with a second wedge. Press together to make a mouth. To make white teeth, carefully press mini-marshmallows into peanut butter.

#### **Melt in Your Mouth Toffee**

1 pound butter

1 Cup white sugar

1 Cup packed brown sugar

1 cup walnuts

2 cups semisweet chocolate chips

In a heavy saucepan, combine butter or margarine, white sugar, and brown sugar. Cook over medium heat, stirring constantly until mixture boils. Boil to brittle stage, 300 degrees F (150 degrees C). Remove from heat.

Pour nuts and chocolate chips into a 9x13 inch dish. Pour hot mixture over the nuts and chocolate. Let the mixture cool and break it into pieces before serving.

#### **Melt in Your Mouth Peanut Butter Balls**

1 jar Peanut Butter

1 large bag of confectioners sugar

2 sticks butter, melted

Chocolate Almond Bark

Mix all ingredients together except for chocolate. Shape into 1-inch balls. Melt chocolate in microwave and dip balls in being sure to cover completely. Put on wax paper to harden. (Hint—I use toothpicks stuck in the peanut butter balls. Work quickly too the peanut butter gets kind of melted if you don't.)

# CUB SCOUTS SPREAD THE NEWS

## January 2005

### Webelos - Fitness

*NOTE: Requirement 7 for the Fitness activity badge in the Webelos Scout Book asks boys to "Read the booklet Don't Be Tricked by Drugs: A Deadly Game! Discuss it with an adult and show that you understand the material." The revised version of the booklet is now titled "Take a Stand Against Drugs." Local council service centers may have copies, or they can be purchased from the Drug Abuse Task Force, S202, Boy Scouts of America, P.O. Box 152079, Irving, TX 75015-2079.*

The fitness Activity Badge is recommended to be completed in a one month format, as outlined in the Webelos Program Helps booklet. This badge requires considerable work done at home. It is often possible to work something else in the Den at the same time that this badge is worked on. This is one of those badges that you REALLY need to get the parents on board to help early. I would send home the reporting sheet (see below) a week before the badge work starts. You can enlarge the sheet to the desired size.

#### **Fitness Badge Activities at Home**

Your Scout is working on the Fitness Activity Badge this month. This badge, which is required for the Webelos rank, requires work to be done at home. The most important thing is to get your Scout started on his exercises. He was given a 30 day exercise chart on which he chose six exercises to do. It is not mandatory that he do these exercises for 30 days with no interruptions -- he simply needs to be consistent, do his best and try to improve. Please make sure he has the exercise chart in his binder, as we will be doing tests throughout the month.

We will be discussing the following requirements in detail in the Den meetings. As your Scout completes the work in the Den, he needs to tell you about what he has learned. Then, please initial where indicated and make sure this page stays in his binder.

Scout's Name: \_\_\_\_\_

**Requirement 1. With a parent or other adult family member complete the exercises in the pamphlet, "How to protect Your Children from Child Abuse and Drug Abuse," found in the front of this book.**

I have completed Requirement 1 with my Scout (parents initial please): \_\_\_\_\_

**Requirement 3. Tell an adult member of your family five bad effects smoking or chewing tobacco would have on your body.**

I have completed Requirement 3 with my Scout (parents initial please): \_\_\_\_\_

**Requirement 4. Tell an adult member of your family what drugs could do to your body and how they would affect your ability to think clearly.**

I have completed Requirement 4 with my Scout (parents initial please): \_\_\_\_\_

**Requirement 5. Tell an adult member of your family what a balanced diet is and whether or not your diet is.**

I have completed Requirement 5 with my Scout (parents initial please): \_\_\_\_\_

**Requirement 6. Tell an adult member of your family why you should not use alcohol and how it could affect you.**

I have completed Requirement 6 with my Scout (parents initial please): \_\_\_\_\_

# CUB SCOUTS SPREAD THE NEWS

## January 2005

### Webelos - Fitness

#### **THINGS BOYS CAN DO IF THEY DON'T LIKE SPORTS**

Not everyone likes organized sports. Some kids may not enjoy all the rules that are used in sports like baseball and lacrosse. Other kids may like activities that don't require big groups of people. For anyone who isn't into team sports - and even for those who are - there are some really fun exercise choices to keep you physically and mentally fit.

#### **When It's Only You**

1. Just turn on some music and boogie! Dancing is a great aerobic exercise. Invent some new dance moves.
2. Try hopping on your bike (don't forget your helmet!). Take a ride around the neighborhood and see what's going on.
3. If you have skates or blades, give them a spin (don't forget your helmet and pads!). If you skateboard, grab your board, helmet, and pads, and try some new moves.
4. Try jumping rope and counting how many times you can jump before you miss - jumping rope is a great way to get aerobic exercise. Boxers often practice by skipping rope.
5. If you play tennis, try hitting a tennis ball against a brick wall.
6. If basketball's your thing, try shooting hoops and seeing how many you can sink.
7. If you're into soccer, grab a ball, and see how long you can keep it in the air using your feet, knees, and head.
8. Practice hopscotch.
9. See how long you can hop on one foot.
10. Do jumping jacks.

Sometimes being by yourself lets you practice things over and over that you might not have a chance to practice otherwise. When you play with your friends again, they'll be amazed at what you can do!

#### **GAMES THAT PROMOTE FITNESS...BUT NOT A LOSER**

Gym classes introduce kids to team sports like football, basketball, soccer, and kickball - games that end with winners and losers. In no-loser games, everyone wins!

**Hackey Sack** - A Hackey Sack is a soft, leather, bean-filled bag about the size of a Ping-Pong ball. Using only their feet, knees, and legs, two or more players try to keep the sack in the air for as long as possible. Some kids practice Hackey Sack alone because it helps them become more balanced and coordinated.

**Marco Polo** - Played in chest-deep water. This game works with just two players, but the more the merrier. One player is "it" (like in tag). He keeps his eyes closed during the game. At any time, he may cry out "Marco," to which every other player must respond "Polo." He then tries to tag another player. The first tagged becomes the new "it," and the game starts again. Marco Polo is not only fun, it can be a good workout. It also puts less stress on your bones and joints because the water makes your body float.

# CUB SCOUTS SPREAD THE NEWS

## January 2005

### Webelos - Fitness

#### Resistance activity

Action that tones your muscles and keeps them strong, is just as important as aerobic exercise. But helping around the house can do more for you than make your mom or dad proud. For example, playing badminton for 30 minutes burns about 170 calories, but 30 minutes of helping your mom or dad dig a garden can burn **200** calories!

A short list of "around-the-house" resistance activities includes raking leaves, shoveling snow, and even kneading bread. Bones, like muscles, become stronger from resistance activity. Splitting firewood, scrubbing floors, and moving furniture will help keep your joints well-lubricated and protected.

#### Aim for Fun

The key to staying fit is finding activities that are fun and challenging. Who's going to stick with something that's boring? When fitness and fun are your goals, you don't need a sports uniform or a bunch of people.

#### Why Is It Important to Stay Fit?

Exercise is good for you for lots of reasons: it keeps you strong, healthy, and happy. Staying fit is the goal. How you do it - alone or with others, helping around the house, or joining a team - is up to you.

#### Other Calorie Burning Activities

Fitness activities you can do alone, with a group, or around the house!

- biking
- chopping firewood
- cleaning windows
- climbing a tree
- dancing
- flying a kite
- doing laundry
- hiking
- horseback riding
- in-line skating
- jogging
- jumping rope
- making a snowman
- martial arts
- mopping floors
- moving furniture
- playing hopscotch
- pull-ups
- push-ups
- rowing a boat
- running in place
- shoveling snow
- sit-ups
- skateboarding
- skipping
- throwing a Frisbee





# CUB SCOUTS SPREAD THE NEWS

## January 2005

### Webelos – Fitness

#### Other Calorie Burning Activities continued

- tug-of-war
- vacuuming
- walking the dog
- washing the car
- weeding
- yoga

Whatever is going on, it's always the right time to exercise! You don't need fancy equipment or expensive sneakers. You don't need a ton of friends around. Sometimes you don't even need to leave the house to get exercise.

#### More things to do when there are two friends:

- Have a handstand contest.
- Ride bikes (don't forget your helmets).
- Practice pitching and hitting a baseball.

#### More things to do when there are a lot of friends:

- Have a skateboarding contest.
- Play tag.
- Play outdoor hide and seek.
- Dance to your favorite music.
- Take an adventure hike.

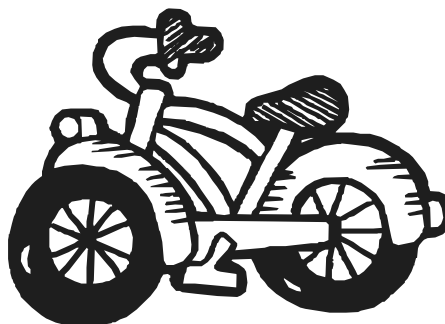

#### More things to do when it's hot and sticky:

- Wash your dog outside.
- Wash your parents' or neighbors' car.
- Play Frisbee over a sprinkler.
- Practice doing sprints through a sprinkler.

#### More things to do when you're stuck at home:

- Gymnastics or tumbling (make sure you have enough room).
- Set up a scavenger hunt.
- Hit a balloon or balled-up sock around and try not to let it hit the floor.
- Play Twister.

# CUB SCOUTS SPREAD THE NEWS

## January 2005

### Webelos - Fitness

#### FACTS ABOUT SMOKING

- According to the World Health Organization, there are 1.1 billion smokers worldwide and 6000 billion cigarettes are smoked every year.
- According to the US Centers for Disease Control, there are about 47 million adult cigarette smokers in the US. Moreover, tobacco use in the US results in more than 430,000 deaths each year (about 1 in 5 deaths.) The economic costs of tobacco use cost more than \$100 billion.
- The New Straits Times (August 11, 1997) reported on a "smoking contest" between two young men (ages 19 and 21 year old). These two men wanted to see who could smoke the most cigarettes at a single sitting. The result was tragic: the 19 year old died after smoking 100 cigarettes and the 21 year old was seriously poisoned after smoking 80 cigarettes. It goes without saying, "Don't try this at home!"
- "Bidi" cigarettes are **NOT** safe alternatives to regular cigarettes. A bidi cigarette has **THREE** times more nicotine and carbon monoxide and **FIVE** times more tar than a regular American cigarette. (Statistic from Yen et al., *Archives of Pediatric and Adoles. Medicine*, 154:1187-1189, 2000.)
- The cost of a pack of cigarettes in New York is about \$7.00. Therefore, a person who smokes one pack of cigarettes each day will spend \$2,555.00 each year on tobacco. (Reference: Associated Press story, "With packs hitting \$7, smokers try to kick habit" reprinted in the *Seattle Times*, July 13, 2002.)
- More than 100 chemicals are added to tobacco to make cigarettes. These chemicals include benzaldehyde, butyric acid, decanoic acid, ethyl acetate, hexanoic acid, 3-methylbutyraldehyde, methylcyclopentenolone, and tolualdehydes. (Reference: Philip Morris USA.)

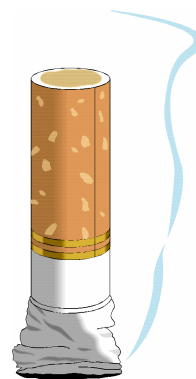

#### ACTIVITIES THAT WILL HELP THE BOYS UNDERSTAND THE HARMFUL EFFECTS OF CIGARETTE SMOKING

Discuss pollutants in the air - Use pictures from magazines or newspapers. Include: factory smoke, car exhausts, rocket launches, and smoke from someone else's burning cigarette and so on.

Explain how all living things need air to breath

Put a plant under an airtight container. What begins to happen? The same thing is happening to your lungs each time you smoke a cigarette.

Put ants or other insects in an airtight jar. Give them everything else they need except air. What happens? Why? (When the insects activity begins to decrease open jar and set them free)

# CUB SCOUTS SPREAD THE NEWS

## January 2005

### Webelos - Fitness

#### **SMOKING Continued**

Talk about the fact that smoking cigarettes is harmful to our health and how it “pollutes” the internal environment of our body (the lungs).

Demonstrate the effect of sick or injured lungs:

Light a candle. Ask a boy to stand a reasonable distance from the candle. Instruct the boy to take a deep breath and then blow out the candle

Relight the candle. Ask the boy to stand at the same distance from the candle. Instruct him to take a deep breath and blow out at least half of the breath before attempting to blow out the candle. With the breath that is left, ask the boy to blow out the candle. What happened?

#### **FACTS ABOUT SMOKELESS TOBACCO**

Some ads you see now try to make the smokeless tobaccos appear clean and good, sort of like a “safe” or “good” substitute for smoking. Try to give your Webelos Scouts a closer and more realistic look at the act and consequences of chewing and dipping.

Chewing tobacco calls for a golf ball sized wad to be placed in the pouch of the cheek and sucked. Just think about that close contact between your flesh and tobacco. The spitting that goes with getting rid of the tobacco juices is unmannerly.

Why put something in your mouth so repulsive that you have to spit it out again?

Dipping is the process of putting a pinch of tobacco (snuff) between the lower lip and teeth. There it stimulates the flow of saliva and mixes with it. The saliva must either be swallowed or spat out frequently.

As repulsive as spitting is, the use of smokeless tobacco seems to be increasing. It is important to counter this with solid facts on the dangers of smokeless tobaccos.

Smokeless tobacco does not carry the same health hazard warning that cigarettes do, but they should. Smokeless tobaccos are dangerous and are habit forming.

Habitual use of chewing tobacco and snuff can cause oral cancer. It also can cause a lessening sense of smell and taste. It also causes dental problems like receding gums, tooth decay, bad breath and discolored teeth.

#### **ACTIVITES TO HELP THE BOYS UNDERSTAND THE EFFECT OF SMOKELESS TOBACCO**

Have a dentist come and talk to the boys about the use of smokeless tobacco

If you know of an individual who use to use smokeless tobacco, see if he or she would be willing to talk to the boys.

Call the National Cancer Institute’s Cancer Information Service at 1-800-4-CANCER and request information to share with your scouts.

During 1996, the danger of smokeless tobacco have received more publicity than usual due to baseball pro pitcher BRETT BUTLER being diagnosed with mouth cancer. Although he gave up the use of smokeless tobacco several years ago. Butler is an example of a fine, healthy young man whose past habits have perhaps caught up with him. For the story of another professional ballplayer whose use of smokeless tobacco apparently contributed to his battle with oral cancer, see the October 1996 issue of “READER’S DIGEST”, page 120. In this article, “My War with a Smoke-Free Killer, former professional ballplayer Bill Tuttle describes his three year battle with mouth cancer. Reprints of the Bill Tuttle article are also available through the Reader’s Digest Reprint Service at 1-800-289-6457.

# CUB SCOUTS SPREAD THE NEWS

## January 2005

### Webelos - Readyman

#### DISCUSS WITH THE BOYS

##### In Case of Emergency

The best way to handle an emergency is to be prepared for one. Knowing what to do ahead of time can help you stay calm enough to help. Here are some suggestions on how to be ready to help in an emergency:

- Know your local emergency number. In most areas in the United States, it's **911**. If your community has a different number, learn it and know it by heart.
- Learn first aid. Look for basic first-aid classes with your local Red Cross, the YMCA or YWCA, the Boy or Girl Scouts, 4-H clubs, and other organizations. Or ask your school nurse to have a first-aid class just for students in your school.
- Keep a list of emergency numbers by every phone in your house. Ask your parents to preprogram their cell phones with these numbers.
- If you are babysitting at another house (or someone is staying with you), make sure an adult leaves a list of emergency numbers (as well as the exact address of the place where you are babysitting) close by, just in case.

The most important thing to do in an emergency is to call for help right away. You could yell "Help!" You could get an adult or send someone to call the local emergency number. Or you could make the call yourself.

If you are going to be the one making the emergency phone call, here's what to do:

- Take a deep breath to calm down a little.
- Tell the operator there's an emergency.
- Say your name and where you are (the exact address if you know it).
- Explain what happened and how many people are hurt. (The operator will need all the information you can provide, so give as many details as you can.)
- Stay on the line until the operator says it's OK to hang up.
- 

Here's something you may wonder about. What happens if you call 911, the rescue people come, and then it turns out that the person wasn't hurt too badly after all? Will anyone be *mad* at you? No! Absolutely not! Even if you're not sure just how serious the accident is, always make that phone call. This is exactly what the rescue people want you to do, and you might be saving someone's life.

##### What Not to Do in an Emergency

If you see someone get hurt, your first thought should be to call for help. Your second thought might be to rush right to the victim. But **stop and look** before you do. Is the scene safe? There could be a real danger, like live electrical wires on the ground or fire nearby. Or maybe the person is in the middle of traffic on a busy road. If it isn't safe, don't go near the victim.

And save the Superman stunts for the movies. That means don't try to do something like drive a car or run into a burning building. You could cause another accident or make the situation worse - you could get hurt, too.

# CUB SCOUTS SPREAD THE NEWS

January 2005  
Webelos - Readyman

## READYMAN OBSTACLE COURSE

Station # 1 <b>(blanket and walking sticks)</b>	Stretcher	At this point the partners will make a stretcher and carry it 20 feet.
Station # 2 <b>(blanket or tarp)</b>	Rescue Breathing	Here the boy will position his partner to do rescue breathing. Tell each step as he does it.
Station # 3 <b>(Bicycle and helmet)</b>	Bicycle Safety	Tell the boy all of the signals and he will have to demonstrate them.
Station # 4 <b>(chair)</b>	Choking	The boy will need to demonstrate the Heimlich maneuver from the sitting position.
Station # 5 <b>(phone)</b>	Call 911	The first cub will yell out an emergency, and the other cub will have to identify himself, tell what happened, and tell the location.
Station # 6 <b>(band-aid and gauze)</b>	Direct Pressure	The first cub will hold a gauze on a wound and count to 10 and the second cub will administer a band-aid.
Station # 7 <b>(Burn pictures)</b>	Burns	The cub will have to put the pictures in order. They will be mixed up between runners.
Station # 8 <b>(large box)</b>	Fire Crawl	The cub will crawl through the box pretending there is smoke above it.
Station # 9 <b>(Milk Jug Bouy and tarp)</b>	Water Rescue	Throw the Milk Jug to the cub on the other side of the water (tarp).
Station # 10 <b>(Baby car seat and large doll)</b>	Car Safety	Buckle the baby in the car seat.

# CUB SCOUTS SPREAD THE NEWS

## January 2005

### Webelos - Readyman

WEBELOS



READYMAN

**BLEEDING** Apply pressure directly on the cut. Help control bleeding by raising the cut arm or leg above body level while applying pressure.



If still bleeding badly, use pressure points. Press the artery against the bone. Press the artery above the cut.

**POISONING** Find out what poison was taken. Find the container when possible, and follow directions on the label. **CALL FOR HELP!** Poison control number is: 581-2151 or 1-800-456-7707. Never make a person vomit unless you know what poison was taken. Try to dilute the poison instead by making the victim drink a glass of water or milk, OR follow directions given. If instructed to get victim to vomit, press down on the back of the tongue with your finger or spoon to make them gag.

**BREATHING** Call for help!

**Step 1:** place victim face up. Lift chin with your right hand, push forehead down with your left hand.  
**Step 2:** Pinch the victim's nose. Seal your mouth over victim's mouth. Blow into mouth to fill lungs with air. Watch for the chest to rise.  
**Step 3:** Remove your mouth. Take deep breath and count slowly to five. Watch to make sure the chest falls as air escapes. Give one breath every 5 seconds. If victim's chest does not rise when you blow in, the airway might be blocked. Turn the head to one side. With your finger see if there is anything in the mouth. If there is, pull it out.

**HEART ATTACK** Here are the signals of heart attack:

- +A feeling of pain or pressure in the center of the chest. It may come and go. Sharp twinges of pain usually are not signals of a heart attack.
- +Sweating when the room is not hot.
- +Victim feels like throwing up.
- +Shortness of breath.
- +Feeling of weakness.

Many times the victim will deny that he is in trouble and say he will be all right. Make him sit halfway up, and call for help anyway. Better to have a false alarm than a disaster!

**CHOKING** If victim is awake, and can speak, cough or breathe, do not interfere. Encourage to cough it up. If the victim can't speak, cough, or breathe, do the Heimlich maneuver: get behind the victim and wrap your arms around waist. Make a fist with thumb on stomach, below the rib cage and slightly above the navel. Grasp your fist with your other hand and press into the victim's stomach with a quick thrust. Repeat until object coughs out. If victim is unconscious, lay on back, sit on victim's hips, place heel of hand on stomach and push with other hand upward. Check for object, continue until help arrives or object is out.

**SHOCK** Shock is serious, and should be expected after any injury. Victim can be faint, weak, and pale. Skin feels cold and clammy. They shiver, seem dazed, and may vomit. Keep victim warm, raise feet higher than heart level, and give sips of water if awake. If you think the head has been injured, just lie him down and raise head slightly. Keep victim quiet and help make him comfortable.

**CUTS AND SCRATCHES** The main thing to remember is to clean them with soap and water, then cover with a sterile bandage. Keep the bandage dry. If it gets dirty or wet, put on another clean bandage. For larger wounds, wash with soap and water. Cover with a gauze pad large enough to cover the wound. If you have no medical tape to keep it on, use a cloth bandage, tied with a square knot.

**BURNS AND SCALDS** For burns where skin is not broken, and has no blisters, put burned part in cold water, or use cold, wet cloths or ice. Ice can be put directly on the burn. Do this until the pain stops. If burned by chemicals, wash burned area with lots of water. Don't use creams or ointments. Cover any blisters with a bandage. If skin appears "cooked" or charred, cover areas with a clean cloth and get medical help fast. Do not remove any clothing from around the burn. Remember to treat for shock!

First Aid book. Cut out and staple together for the first aid kit

# CUB SCOUTS SPREAD THE NEWS

## January 2005

### Tigers - Keeping Myself Healthy and Safe

#### Family Activity

#### HAVE A FAMILY MEETING AND DISCUSS

##### When to Call 911

Sometimes people are confused about when to call 911. These are examples of when **not** to call 911:

- you can't find your favorite toy or your homework from last night
- your cat got into a fight with another cat
- your brother or your friend dares you to call
- you have a nasty hangnail
- 

**Never** call 911 as a joke or just to see what might happen. When the emergency dispatcher has to take the time to talk to people who don't have a real emergency, other people who call and do need help right away might have to wait.

The only time you should call 911 is if a person is badly hurt or in danger *right now!*

- Can you call 911 if there's been a car accident? **Yes!**
- Should you call if you see a crime, like someone hurting someone else or breaking into a person's house? **Of course!**
- What if someone suddenly seems very sick and is having a hard time speaking or breathing or turns blue? **Call right away!**
- What if someone collapses or passes out? **Absolutely call!**
- What if someone's house is on fire? **Definitely call!**

Talk to your boys about when they should call 911. If their not sure whether there's a real emergency and there are no adults around, it's a good idea to make the call. Just remind them, "**When in Doubt, Dial It Out: 9-1-1.**" They could save someone's life!

#### Den Activity

##### BANDAGE SLING AND SPLINT RELAY

Equipment: Bandages and splints

Have two teams, a Tiger Cub and his adult partner. Be sure there's enough bandages for each injury. A splint can be made out of tightly rolled newspaper. Strips of cloth can be tied to the splint. Have bandage wrapping for head injuries and some soft bandages for eye wounds. Use a neckerchief for a sling.. Before doing this relay be sure that you have practice and taught the boys the correct way to bandage a wounded person. With the parents as the wounded, see who can do the job the quickest and the bandages remain on for at least ten seconds.



# CUB SCOUTS SPREAD THE NEWS

## January 2005

### Tigers - Keeping Myself Healthy and Safe

#### Den Activity

Emergency information is available from local libraries, the American Red Cross and the local fire departments. Some free handouts can include family disaster supply kits from the local fire department and the Red Cross.

#### Emergency Preparedness Ideas to consider:

Does your group have emergency supplies at the meeting site? Are there food supplies, warm blankets, flashlights, and water tucked away, just in case?

At home, how do you shut off the gas, the water and the electricity?



What neighbors can help? Have a neighborhood emergency plan ready. Who can be called when needed?

Every Tiger Cub will experience fire drills and storm drills at school. Do you have one established at your meeting site?

#### WHAT DO THEY SAY

What do you say when someone is pressuring you to break the rules, try drugs, alcohol, smoke a cigarette, or do something you don't want to do? Here are some suggestions. Try role playing with the boys to help them feel comfortable with saying no. You can also try ignoring the remark or simply leaving the room.

<b>Make an excuse.</b>	<i>"I've got a book report due."</i>
<b>Change the subject.</b>	<i>"I like your shoes. Where'd you get them?"</i>
<b>Make a joke.</b>	<i>"I wish I could, but I've got to walk my goldfish."</i>
<b>Act shocked.</b>	<i>"I can't believe you even suggested that."</i>
<b>Use flattery.</b>	<i>"You're too smart to really mean that."</i>
<b>Offer a better idea.</b>	<i>"Why don't we watch TV instead?"</i>

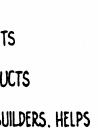
<b>1. MILK GROUP</b> • MILK & MILK PRODUCTS • CHEESE • COTTAGE CHEESE • ICE CREAM BUILDS TEETH AND BONES! 	<b>2. FRUIT-VEGETABLE GROUP</b> • ALL KINDS OF FRESH FRUITS AND VEGETABLES • RAISINS BUILDS ENERGY AND HELPS YOUR BODY DEFEND AGAINST DISEASE. 
<b>3. PROTEIN GROUP</b> • BEANS • MEAT • FISH • PEANUT BUTTER • EGGS BUILDS MUSCLES, BONES AND BLOOD 	<b>4. BREAD-CEREAL GROUP</b> • RICE • CEREAL & GRITS • BREAD • FLOUR PRODUCTS • SPAGHETTI QUICK ENERGY BUILDERS. HELPS TO MAKE YOUR BODY WORK BETTER. 

No program concerning fitness should leave out the subject of NUTRITION! Tiger Partners should plan to have some discussion of the importance of good nutrition. You might have a den discussion of the variety of good food for proper growth and development. The following chart about the 4 basic food groups might be helpful.

#### FITNESS

*Tune: On Wisconsin*

Hurry, Tigers,  
 Build your muscles,  
 Get in shape for play.  
 When we feel our very best,  
 We'll do our best each day.  
 (Rah, rah, rah)  
 Keep on running, keep on jumping,  
 Trying to improve.  
 When we've grown a little older,  
 We'll still be on the move.





# CUB SCOUTS SPREAD THE NEWS

## January 2005

### Tigers - Keeping Myself Healthy and Safe

#### HEALTH POSTER/ FOOD INTAKE CHART

To drive home the idea of nutrition's importance, have the boys make posters on that theme. After they have been displayed at the Pack meeting, see if a local grocery or health food store will let you display them for a week. Here are some ideas for posters. Another activity would be to have the boys chart their food intake for a week and then review them together at the next meeting



#### OBSTACLE TRACK RELAY

Split the group into two teams including the Tiger partners. The first tiger on each team will run the 50-yard dash touch the next person hand. That person will do the broad jump when touch the next person in line. The third will run the hurdles, the fourth will do a high jump (not too high), and the fifth will throw the shot put to the finish line. If the ball does make it they will pick it up a continue to throw it until it makes it over the line. First team done wins.

#### Go and See It Outing

- ◆ Visit a dentist office
- ◆ Visit a nursing station
- ◆ Visit a walk in clinic
- ◆ Visit a paramedic unit
- ◆ Visit a hospital
- ◆ Visit a nutritionist
- ◆ Visit a fitness center
- ◆ Visit a doctors office

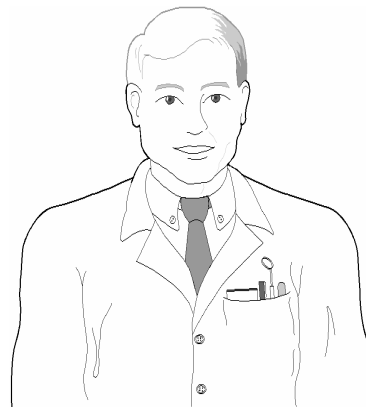

# CUB SCOUTS SPREAD THE NEWS

## January 2005

### Cubmaster Corner - Arranging for Special Guests

#### Distinguished Guests and Basic Protocol

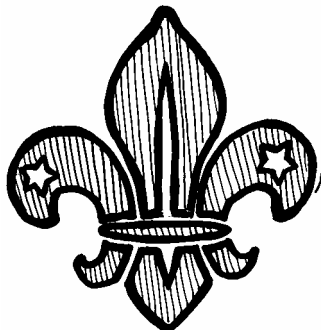

#### Invitations

1. Write or call your guest or speaker when you have selected your program. If you call, follow up with a written confirmation. Advise all guests of their particular function at the meeting. Include a brief outline of the tentative program and a data sheet on our organization with its aims and purposes. Tell them why the group would appreciate having them as a guest or speaker.
2. Let them know the time allocated for their speech or remarks; the time the meeting will start; and the probable time of adjournment.
3. Find out if your guest would like to be excused early. They may have other commitments and not wish to stay for the business or entertainment portion of the meeting.
4. Request confirmation and ask for material that may be used for advance publicity or in introducing them. Ask if they object to being interviewed by the press or photographed.
5. Tell them if they plan a question-and-answer period following their talk.
6. Give your guest or speaker some idea of what you would like discussed.
7. Let your guest or speaker know the type of meeting (dinner, luncheon, etc.) And dress (Formal, semi-formal, business).
8. Let them know in writing, the place of the meeting, including the address and directions on how to get there.
9. If the trip requires an overnight stay, suggest types of accommodations available. Make reservations if they request you to do so. Find out if they need transportation.
10. Let your guest know who will escort them and for whom to ask upon arrival. If possible, tell them who will introduce them and send them a copy of your program.
11. A day or two before the meeting, call or write your guest reminding them of the upcoming meeting.
12. If they need tickets, see that complimentary ones are provided in advance.

# **CUB SCOUTS SPREAD THE NEWS**

## **January 2005**

### **Cubmaster Corner - Arranging for Special Guests**

#### **Preliminary Planning**

1. Check to see that your meeting place is well lighted and ventilated.
2. Check to see that the podium light works, as your guest may wish to use notes.
3. Check to see that sufficient chairs are available and that there are seats reserved for your guests both on the platform and in the audience.
4. Check the public address system and be sure it works properly.
5. If your guest has asked for special equipment such as a projector, screen, white board, Etc., see that it is set up and in working order.
6. Have a container of water and a glass available.
7. Arrange for distribution of programs in an orderly manner.
8. Be sure the kitchen or refreshment committee is seated near an exit so they may leave at a pre-arranged signal without fuss and confusion.
9. If you have made arrangements for overnight accommodations for your guest, allow some time for them to be alone and relax. Be sure to consult them before arranging parties or other activities.
10. If you cannot meet your guest yourself, be sure to appoint someone to escort them to all meetings, as well as their departing transportation.
11. Arrange to have guests met at the door, if possible, by the Distinguished Guest Chairman. If they are to be escorted at the beginning of the meeting, they are seated in a group at the rear of the room. See that they are introduced to those seated with them.
12. Instruct your committee to notify you immediately upon arrival of a guest.
13. If a gift or corsage is to be presented, arrange for the bill to be submitted at another meeting, not when the guest is present.
14. If a corsage is to be presented, one person should be designated to present and pin it. Arrange to have this done before the meeting starts.
15. The person conducting the meeting may accept a corsage, but she does not wear it unless the guest also wears one. (In case of a male guest, he should be pinned with a boutonniere.) White is a safe color for a corsage, since it will blend with any color your guest may wear.

# CUB SCOUTS SPREAD THE NEWS

## January 2005

### Cubmaster Corner - Arranging for Special Guests

#### Preliminary Planning Continued

16. If a guest brings a companion, be sure they are introduced to the persons seated on either side of them. Ascertain their correct name, and if they have a title. Be sure they are introduced to the assembly.
17. If the speaker or guest wishes to leave at the end of their part of the program, thank them on behalf of the group and have the "escort" conduct them to their transportation.
18. If you are giving your speaker a fee, expense money, or a gratuity, present it in an envelope before they leave.
19. Guests should never be expected to participate in drawings or raffles.

This is basic protocol. You may add to it. Most units, districts, and departments have traditions and customs that make these basic rules more personal. The main thing to remember is to use common sense, courtesy, and above all, never to embarrass any one.



## THE WEBELOS PROGRAM

Welcome to Webelos! These pages are meant to give you a better understanding of the Webelos Scout program. Along with an overview of the Webelos program, you will find the requirements for the Webelos rank, activity pins and the Arrow of Light Award.

The goal of Webelos Scouting is to provide the Scouts with as many experiences as possible to help him grow and learn to shoulder the new responsibilities he will have as a Boy Scout. A major role of the two-year Webelos program is that of providing an environment where boys can learn more about Boy Scout skills

Have fun, be creative, and let the Webelos spread their wings as they prepare for Boy Scouting. Give them respect and expect it in return. Give them responsibility and expect it to be carried out. Give them the opportunity to begin to direct their own Scouting career and watch them grow.

A Webelos Scout is at the time in his life when he can begin to take responsibility for his own life, with a lot of guidance. He will want some input into how the den operates, give him the opportunity to lead some activity, require some effort on his part, and reward his effort with praise and earned advancement. Webelos' want attention and recognition. The success of the Webelos program is directly proportional to the success of the advance/recognition program.

### ADVANCEMENT PLAN

The Webelos Scout advancement plan is the basis for the program. Den meetings and Webelos Scout participation in pack meetings, as well as other activities, are usually built on one of the twenty activity badges or pins, plus the Webelos badge and Arrow of Light.

Implementing the Webelos program for Webelos Scouts will depend on the starting date and graduation date of the boys in the den.

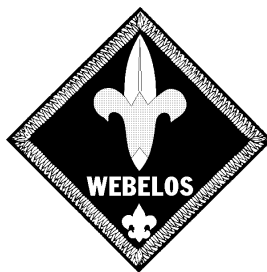

As soon as a boy joins the Webelos den he begins working immediately on the requirements for the Webelos Rank and activity badges that are required for the rank.. This usually is done during the first year, and the Arrow of Light Award during the second year.

Certain activity badges are required for earning the Webelos badge and the Arrow of Light award, while others may be selected by the boy. The twenty activity badges are hobby and career fields ranging from science to sports.

**ACTIVITY BADGES**

Under the advancement requirement, the twenty activity badges are arranged into five groups, each containing four related badges. For both the Webelos badge and the Arrow of Light Award, the boy is required to earn activity badges from different groups in order to broaden his experience in different areas. Three of the activity badges are required—one (Fitness) for the Webelos badge, and two more (Citizen and Readyman) for the Arrow of Light Award. The activity badge groups are:

**PHYSICAL SKILLS GROUP**

- \*Aquanaut
- \*Athlete
- \*Fitness
- \*Sportsman

**MENTAL SKILLS GROUP**

- \*Artist
- \*Scholar
- \*Showman
- \*Traveler

**TECHNOLOGY GROUP**

- \*Craftsman
- \*Engineer
- \*Handyman
- \*Scientist

**COMMUNITY GROUP**

- \*Citizen
- \*Communicator
- \*Family Member
- \*Readyman

**OUTDOOR GROUP**

- \*Forester
- \*Geologist
- \*Naturalist
- \*Outdoorsman

**COMPASS POINTS**

After completing the Webelos badge, the Webelos Scout may receive compass points for earning additional activity badges. The Compass Points emblem is presented to the boy who has earned four activity badges in addition to those required for the Webelos badge (a total of seven). A metal compass point is awarded for each additional four activity badges earned. It is attached to the button on the right pocket flap of the Webelos uniform blue or khaki shirt.



**WEBELOS COLORS**

Webelos wear their activity badges either on their Webelos cap or on the Webelos “colors”. It does not matter which badge goes on which ribbon. The Webelos colors go below and touching the den number of below and touching the U.S. flag if there is no den number.

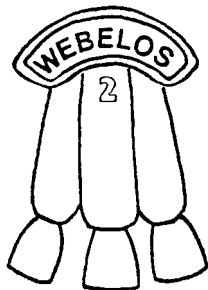

**THE ARROW OF LIGHT AWARD**

The Arrow of Light Award is to the Cub Scouting, what an Eagle rank is to Boy Scouting. Quite simply, the highest honor a Cub Scout can earn. Better yet, the Arrow of Light is the only Cub Scout badge that can be worn on your son’s Boy Scout uniform.

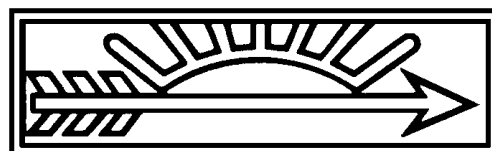

### WEBELOS OUTDOOR PROGRAM



An important part of the 2-year Webelos Scout program is the boys Introduction to basic BSA camping skills, as well as the fun and excitement of camping. Several Webelos Scout parent-and-son overnight campouts should be included in the first year, with emphasis on learning the basic skills of outdoor living and having fun outdoors. The guidelines in the Cub Scout Leader Book, should be followed closely to ensure that the camping experience is comfortable and fulfilling. Encourage the Webelos Patrol and parents to cook meals as a group, not as parent/son meals.

During the second year, camping skills can be expanded, although they should not exceed those taught at the entry level of Boy Scouting. The concept of participation together by the boy and his parent must be maintained. Use improved camping BSA facilities accessible to transportation, rather than wilderness sites. Fire-building, basic cooking, camp sanitation, tent-pitching, making a comfortable ground bed, nature study, and conservation are skills that could be included in camp programs. Also cover the division of jobs (cook, fireman, KP) with a duty roster that rotates for each campout and even at each meal. Start allowing the Webelos Patrol (without parents) to cook some meals together as a group. Let the parents eat separately.

Aside from the fun your Webelos Scouts will have on the overnight, they can complete enough requirements to earn the Outdoorsman Activity Badge by the time they return home.

### JOINT ACTIVITIES WITH BOY SCOUT TROOPS

Early in the second year of the program (if it has not been done previously), a close relationship should be established with the Boy Scout troop that most of the Webelos Scouts will join. This will help the boys to become familiar with the troop and its members and learn about the exciting activities that await them in Boy Scouting.

The Webelos den and the troop should hold several activities together. In addition to one or two joint campouts, the den could also join with the troop in a court of honor, campfire program, day hike, field day, and joint Good Turns for the chartered organization or community. Attendance at a camporee or other district or council Boy Scout event, as guests for the day, of the troop might also be included.

Every graduating Webelos Scout deserves the opportunity to continue his Scouting experience as a member of a Boy Scout troop. That is the purpose of the Webelos-to-Scout transition plan; to give every Webelos Scout a sampling of the troop program, troop leadership, advancement opportunities, and the fun and excitement of Boy Scouting. We also must let him know that he is wanted.

## LEAVING CUB SCOUTING FOREVER

*Equipment: Sign with each insignia on it (Bobcat, Wolf, Bear, Webelos and Arrow of Light), A bridge to walk over.*

**CUBMASTER:** Most awards here are fun, goofy or crazy. Not this one, this is a time to be serious. This is a very important day for these Scouts. They are leaving cub Scouting forever. Starting on a new trail (to Boy Scouts). Receiving the highest award in cub Scouting. The Arrow of Light. Before you is the Cub Scouting trail. *(The signs of each rank)*

**BOBCAT:** The Bobcat is asked to follow the Cub Scout trail and follow the Law of the Pack. You have helped the pack go and we hope it has helped you grow. *(Have boys stand in front of Bobcat sign)*

**WOLF:** As a Wolf you had to learn new skills and start to find your way in advancements. You were required to fulfill 12 Wolf activities – to receive your Wolf badge. *(Have boys stand in front of Wolf Sign)*

**BEAR:** As a Bear you had to learn new and more challenging skills, which required more work on your part, as well as help from your parents and Den Leader. To achieve your Bear badge, you had to achieve 12 Bear activities. *(Have boys stand in front of Bear sign).*

**WEBELOS:** As a Webelos, you had to earn three activity pins and fulfill 15 requirements which were all leading you to the Arrow of Light, which is the hardest of all Cub Scouting ranks to achieve. *(Have boys stand in front of Webelos sign)*

To earn your Arrow of Light, you had to show your knowledge of Scouting. You had to participate in Boy Scout camping. You needed to earn an additional 5 activity pins – which is a big challenge in itself. Some of you have gone far beyond this, earning several more activity pins. You have learned new skills and acquired new knowledge you can use the rest of your life.

Before you, you see the Arrow of Light. This has a special meaning. Did you notice the Indian sign for the sun over the arrow? That is why it's called the Arrow of Light. Notice the seven rays of the sun – one for each day of the week. They will remind you to do your best every day as you follow the arrow that leads you to Boy Scouting.

This is a joyous time – and a sad time. I am happy that you are advancing but sad that you are leaving. I have watched you grow from Bobcats to becoming Boy Scouts. I hope you carry a part of us with you as you grow. You are always welcome to our Pack Meetings.

The Arrow lead you to your final Cub Scout trail – The Bridge to Scouting. *(Present the Arrow of Light, Send boys over the bridge).*

Congratulations on earning your Arrow of Light and good luck on your Boy Scout Adventure.



## CROSSING OVER TO SCOUTING

*Setting: A bridge is in the center stage. One side of the bridge is represented as the Cub Scout side and the other side as the Boy Scout side. You can use your imagination on how to symbolize each side so it is apparent which side is which. Use of Boy Scouts with candles lighting the path is very impressive.*

Cubmaster and Scoutmaster standing appropriate sides.

**CUBMASTER:** Tonight we mark a great occasion- the graduation of \_\_\_\_\_ Webelos Scouts into a Boy Scout troop. We are sad to see them leave because they have been a great help to our pack, but we are happy for them because they are going on to the great adventure of Boy Scouting. These Webelos have worked hard for this night and have advanced well. As a symbol of their hard work, each Webelos Scout will be given an arrow. As I call your name, will each Scout come forward with your parents.

*(Call each boys name off)*

**READER:** The arrow alone gives meaning to each of these Scouts. The wooden shaft gives the strength like the strength the Scout Promise gives each boy. The fletching helps guide the arrow on a straight and true path like the Scout Law guides the Scout on a straight and true path. The arrowhead points the way to the target like Webelos badge and Arrow of Light requirements have pointed the Scout to the ways of Boy Scouting.

Each arrow has these parts – but each arrow is different – it is individual. Each arrow represents their own trail through Cub Scouting. *(Give each boy his arrow)*

It has been a long trail. As you look at the arrow you can look back and see how far you have traveled. Your first trail led you across the Bobcat Ridge, where Akela took you into the Pack as a Bobcat. The yellow mark tells that this boy completed his Bobcat requirements. You may have then climbed the steep Wolf Mountain. The red mark means he has completed the Wolf badge. After that there may be gold and silver marks for the arrow points that you may have earned. After finding your way through Bear Forest, you may have earned your Bear rank. The green mark shows you have gained your Bear achievements, and again you may have earned a gold and silver arrow points. Your trail next may have led you to Webelos Rank – first earning three Webelos pins shown by three black marks, then your Webelos badge which is marked in blue. The Arrow of Light trail may have been hard and rugged. You first earned another four Webelos pins. Then came the highest Cub Scout Achievement, the Arrow of Light that is signified by the white marking on the arrow. The twelve beads will remind you of the twelve points of the Scout Law. The red and white feathers not only stand for the troops colors, but also for devotion and honor.

Your trail in Scouting does not end in Cub Scouting – it is only the beginning – for all of you have prepared yourself for the crossing over the Boy Scouts.

The bridge before you is a symbol of your crossing from Cub Scouting to Boy Scouting. The bridge is a structure carrying a pathway or roadway over a depression. It is a means

of connection or transition from one side to another – as this bridge represents how our Pack is connected to our Troop.

As I call each boys name, please come stand before Your Cubmaster where he will remove your Webelos neckerchief.

*(Cubmaster is calling over to the Scoutmaster)*

**CUBMASTER:** Hello, Boy Scouts of Troop \_\_\_\_.

**SCOUTMASTER:** Hello, Cub Scouts of Akela. What do you desire?

**CUBMASTER:** We have several Webelos who have prepared themselves for entrance into your troop.

**SCOUTMASTER:** Bring them and their parents forward to the bridge that joins our Pack and Troop. I will send two of the Scouts over to escort the boys and their parents over the bridge.

*(Boy Scouts cross over to Pack's side and then escorts the new scout and their parents to the other side)*

Webelos leader speaking to the Scoutmaster: These are your new Scouts, ready for the adventures ahead of them. They are going to call themselves the patrol \_\_\_\_.

Webelos leader speaking to the boys: As I call each of your names, please come forward to your Scoutmaster, where he will place on you the Neckerchief of Troop \_\_\_\_.

**SCOUTMASTER:** I'd like to welcome the new patrol and their families to our Troop.

*(Lights on)*

**SCOUTMASTER:** Will Troop please form your patrols.

*(Have SPL lead all Scouts in the Scout Promise)*



## Citizen Activity Badge – Required for Webelos Badge

---

### Requirements:

*Do this:*

1. With your parent, guardian, or Webelos den leader, complete the Citizenship Character Connections.
  - a. **Know:** List some of your rights as a citizen of the United States of America. Tell ways you can show respect for the rights of others.
  - b. **Commit:** Name some ways a boy your age can be a good citizen. Tell how you plan to be a good citizen and how you plan to influence others to be good citizens.
  - c. **Practice:** Choose one of the requirements for this activity badge that helps you be a good citizen. Complete the requirement and tell why it helped you be a good citizen.

*Do all of these:*

2. Know the names of the president and vice president of the United States, elected governor of your state, and the head of your local government.
3. Describe the flag of the United States and give a short history of it. With another Webelos Scout helping you, show how to hoist and lower the flag, how to hang it horizontally and vertically on a wall, and how to fold it. Tell how to retire a worn or tattered flag properly.
4. Explain why you should respect your country's flag. Tell some of the special days we fly it. Tell when to salute the flag and show how to do it.
5. Repeat the Pledge of Allegiance from memory. Explain its meaning in your own words.
6. Tell how our national anthem was written.
7. Explain the rights and duties of a citizen of the United States. Explain what a citizen should do to save our natural resources.
8. As a Webelos Scout, earn the Cub Scout Academics belt loop for Citizenship. At a Webelos den meeting, talk about the service project Good Turn that you did.

*And do two of these:*

9. Tell about two things you can do that will help law enforcement agencies.
10. With your Webelos den or your family, visit a community leader. Learn about the duties of the job or office and tell what you have learned.

11. Write a short story of not less than 50 words about a former U.S. president or some other great American. Give a report on this to your Webelos den.
12. Tell about another boy you think is a good citizen. Tell what he does that makes you think he is a good citizen.
13. List the names of three people you think are good citizens. (They can be from any country.) Tell why you chose each of them.
14. Tell why we have laws. Tell why you think it is important to obey the law. Tell about three laws you obeyed this week.
15. Tell why we have government. Explains some ways your family helps pay for government.
16. List four ways in which your country helps or works with other nations.
17. Name three organizations, not churches or other religious organizations, in your area that help people. Tell something about what one of these organizations does.

### Suggested Activities:

- Visit a local government agency. Find out how it works, what services it provides, how it affects you and your family.
- Attend a naturalization ceremony or speak with someone who is a naturalized U.S. citizen.
- Visit a local government meeting or school board meeting, police station, or fire station.
- Visit a court. Ask the judge to speak to the boys about citizenship. Acquaint the boys with the court procedure.
- Discuss the difference between the rights and duties of a citizen. Make a chart and display it at a Pack Meeting.
- Fly the flag in your homes and encourage others to do so also.
- Learn more about your community. Your local historical society can help with this.
- Make and hand out litter bags. Tell why litter hurts all of us.
- Make a good citizen poster. Imagine the type of citizen you would want to be part of your community. How would that person act? What would that person look like? Design a WANTED poster of the idea citizen. Cut and paste a picture or photo on a sheet of paper of the citizen you want. Then describe the person physically and also describe his/her personality traits. Example: WANTED – person with good humor, a concern for others, and ability to get along with others. Then complete the following statements on your poster: This person was last seen in \_\_\_\_\_. He/she was \_\_\_\_\_, once again showing himself/herself to be an active and responsible citizen. If you have any information about this person, please contact \_\_\_\_\_. This person is an ideal citizen because \_\_\_\_\_.

## Citizen Ceremonies:

### Pack Meeting Opening:

You will need a reproduction of the Flag of 1812. Have two Webelos Scouts hold the flag while another Scout reads: "Our country's first official flag had 13 stars and 13 strips, one for each of the first states. In 1795, two more states joined the Union and a new flag was made with 15 stars and 15 stripes. It was this new flag, the Star Spangled Banner, that was flying over Fort McHenry in Baltimore when the British bombarded the fort during the War of 1812. Francis Scott Key saw the bombardment and was inspired to write our national anthem. Let us honor this flag by singing the first verse of the anthem."

### Closing:

Personnel: Cubmaster and six Cub Scouts

CM: I asked myself a question today. "What does it mean to be an American?"  
There were several answers, and they were all good. Being an American means I have a multitude of freedoms.

Scout #1: Freedom to think and to say what I think.

Scout #2: Freedom to worship as I please.

Scout #3: Freedom to move ahead.

Scout #4: Freedom to try, and freedom to fail.

Scout #5: Freedom to stand up straight and to look the world in the eye.

Scout #6: Freedom from want, and freedom from fear.

CM: These freedoms were not of my doing. They were here long before I was born. Our forefathers fought to win them. I have four guarantees that they will remain: the Declaration of Independence, the Constitution of the United States, my fellow Americans, and me. No man could ask for more.

From: BB-Greater St. Louis Area Council

Personnel: Den Chief and six Scouts

Den Chief: We have a lot to be thankful for at this time of year. We work and for this we see all the good things that come of it. Let us all share something good with each other at this time.

Scout #1: Do the very best you can and leave the rest to God.

Scout #2: Life is hard by the yard; but by the inch, life is a cinch.

Scout #3: A clean conscience is a soft pillow.

Scout #4: We can do anything if we stick to it long enough.

Scout #5: There is no failure except to give up.

Scout #6: Our country – right or wrong. When right, to be kept right. When wrong, to be made right.

Den Chief: Good night Scouts and families, see you next month.

Adventures in Neverland  
January 2004

---

Games/Quizzes:

Great Documents Quiz: How much do you know about two of the greatest documents ever written . . . the Declaration of Independence and the Constitution of the United States?

1. The first words of the Declaration of Independence are:
  - a) "We hold these truths to be self-evident . . . "
  - b) "We, the People of the United States . . . "
  - c) "When in the course of human events . . . "
  - d) "Four score and seven years ago . . . "
  
2. The first draft of the Declaration of Independence was written by:
  - a) John Hancock
  - b) Button Swinnett
  - c) George Washington
  - d) Thomas Jefferson
  
3. The Constitution of the United States was signed in what year?
  - a) 1776
  - b) 1492
  - c) 1787
  - d) 1620
  
4. Which amendment to the Constitution provided for the abolition of slavery?
  - a) 10<sup>th</sup> Amendment
  - b) 13<sup>th</sup> Amendment
  - c) 3<sup>rd</sup> Amendment
  - d) 16<sup>th</sup> Amendment
  
5. Which amendment to the Constitution guarantees freedom of speech?
  - a) 14<sup>th</sup> Amendment
  - b) 1<sup>st</sup> Amendment
  - c) 29<sup>th</sup> Amendment
  - d) 5<sup>th</sup> Amendment
  
6. Who takes over in the event of the death of the President:
  - a) Secretary of State
  - b) Vice President
  - c) Senator of Virginia
  - d) Secretary of Defense

Answers: 1) c; 2) d; 3) c; 4) b; 5) 8; 6) b



Do You Know Your Flag Quiz

1. The flag is raised
  - a) Slowly
  - b) Briskly
  - c) At any speed that is comfortable
  
2. If you carried the flag in a parade before the President of the United States, you would dip the flag in salute to the President as you walk past him. True or False?
  
3. The flag must never be lowered no matter how bad the weather conditions. True or False?
  
4. The flag is never allowed to fly after daylight hours anywhere in the world. True or False?
  
5. When the flag is carried in parades or other occasions, it is escorted by an honor guard. True or False?
  
6. The flag's honor guard walks:
  - a) On the flag's right
  - b) Just behind the flag
  - c) On either side of the flag
  
7. If you are a Cub Scout, Boy Scout, or Explorer, you always give the Cub Scout, Boy Scout, or Explorer salute to the flag whether or not you are in uniform. True or False?
  
8. When you carry the flag in a parade with other flags, the U.S. flag must go on the left of and in line with the other flags. True or False?
  
9. When the flag is hung against the wall, the stars are placed in the upper left corner (as you look at it) when the stripes are horizontal, but in the upper right corner when the stripes are vertical. True or False?
  
10. The only time a flag is flown upside down is as a signal for help. True or False?

Answers: 1) b-briskly. It is a happy occasion.  
2) False. The flag is never dipped to anyone.  
3) False. The flag is not flown in bad weather.

- 4) False. Although it is the custom to display the flag only from sunrise to sunset, there is no law prohibiting its being flown both day and night with illumination.
- 5) True.
- 6) On either side of the flag.
- 7) False. When you are in civilian clothes, you remove your hat and place your right hand over your heart when the flag passes.
- 8) False. It is carried on the right of the other flags or at the front of the center of the line of other flags.
- 9) False. The stars should be in the upper left corner as you look at it (the flag's right) regardless of whether the stripes are horizontal or vertical.
- 10) True.

## Fitness Activity Badge – Required for Webelos Badge

---

### Requirements:

#### *Do This:*

1. With your parents, guardian, or Webelos den leader, complete the Health and Fitness Character Connection.
  - a. **Know:** Tell why it is important to be healthy, clean, and fit.
  - b. **Commit:** Tell when it is difficult for you to stick with good health habits. Tell where you can go to be with others who encourage you to be healthy, clean, and fit.
  - c. **Practice:** Practice good health habits while doing the requirements for this activity badge.

#### *And do six of these:*

2. With a parent or other adult family members, complete a safety notebook, which is discussed in the booklet "How to Protect Your Children from Child Abuse" that comes with this book.
3. Read the meal planning information in this chapter. With a parent or other family member, plan a week of meals. Explain what kinds of meals are best for you and why.
4. Keep a record of your daily meals and snacks for a week. Decide whether you have been eating foods that are good for you.
5. Tell an adult member of your family about the bad effects of smoking or chewing tobacco would have on your body.
6. Tell an adult member of your family four reasons why you should not use alcohol and how it could affect you.
7. Tell an adult member of your family what drugs could do to your body and how they would affect your ability to think clearly.
8. Read the booklet *Take a Stand Against Drugs!* Discuss it with an adult and show that you understand the material.

NOTE: The booklet "Take a Stand Against Drugs" should be available from your local Boy Scout Council Office (NOT the Scout Shop). Copies may also be purchased from the Drug Abuse Task Force, Boy Scouts of America, P.O. Box 152079, Irving, TX 75015-2079.

## Suggested Activities:

- YMCA director, health class teacher, personal trainer, coach, CPR instructor, camp staff, insurance company public relations.
- Invite the grade school gym teacher to your meeting. Get to know them on a personal basis: why did they become a teacher? What kind of background do they have? What sports are they currently active in? What do they like about teaching kids?
- Arrange a visit to the YMCA or local health club. Tour the whole facility looking at all the machines. Meet briefly with various instructors to find out what they do. Look at a schedule of classes. Get some fitness tips from a personal trainer. Ask what they do for emergencies.
- Find out if there is a nurse or doctor in your pack who would be willing meet with your den to answer questions about health. (Have boys write the questions on cards so they are anonymous.)
- Have the boys read a story in the newspaper or magazine about a drug or alcohol related incident. Have them report back to the den and discuss what happened.
- Invite a nurse, doctor, EMT, or police officer to talk about the effects of tobacco, drug or alcohol abuse as well as the positive effects of eating a healthy diet.
- Visit with/invite to a den meeting a dietitian and talk about the four food groups and planning means.
- Visit a dentist's office and talk about dental health.
- Let the boys design posters on how to say no to drugs, cigarettes and alcohol. Display at pack meeting.

## **Outdoorsman Activity Badge – Required for Arrow of Light**

---

### **Requirements:**

*Do Two of These:*

1. Present yourself to your Webelos den leader, properly dressed, as you would be for an overnight campout. Show the camping gear you will use. Show the right way to pack and carry it.
2. With your family or Webelos den, help plan and take part in an evening outdoor activity that includes a campfire.
3. With your parent or guardian, take part in a Webelos den overnight campout or a family campout. Sleep in a tent that you have helped pitch.
4. With your parent or guardian, camp overnight with a Boy Scout troop. Sleep in a tent you have helped pitch.

*And Do Five of These:*

5. During a Webelos den meeting, discuss how to follow the Leave No Trace Frontcountry Guidelines during outdoor activities (found on page 72 of the Webelos Book).
6. Participate in an outdoor conservation project with your Webelos den or a Boy Scout troop.
7. Discuss with your Webelos den leader the rules of outdoor fire safety. Using these rules, show how to build a safe fire and put it out.
8. With your accompanying adult on a camping trip or outdoor activity, assist in preparing, cooking, and cleanup for one of your den's meals. Tell why it is important for each den member to share in meal preparation and cleanup and explain the importance of eating together.
9. Discuss with your Webelos den leader the things that you need to take on a hike. Go on one three-mile hike with your Webelos den or a Boy Scout troop.
10. Demonstrate how to whip and fuse the ends of a rope.
11. Demonstrate setting up a tent or dining fly using two half hitches and a taut-line hitch. Show how to tie a square knot and explain how it is used.
12. Visit a nearby Boy Scout camp with your Webelos den.

Suggested Activities:

- Invite a Boy Scout (recommended by his Scoutmaster) to come to a den meeting and discuss the differences between cold and warm weather camping and the gear you would need for each.
- Make Quick Fire Starters as a den project.
- Gather different types of sleeping bags and discuss the advantages/disadvantages of each type.
- Make some outdoor utensils.
- Learn how to foil cook.
- Learn the outdoor code.
- Discuss hiking safety rules.
- Plan and hold a Webelos camping weekend.

### Quick Fire Starters:

Materials: Newspapers, string, wax, a large can, and an old pot to melt wax in.

Melting is best done with a double-boiler method, in which the can with wax is placed inside a large container that has water up to about two inches from the lip of the can. An adult should handle this chore. Melt two or three blocks of wax (home canning size) or a handful of old candles. While the wax is melting, have each Webelos scout roll a section of about 18 pages of newspaper into a tight cylinder. Tie the cylinders with string about every two or three inches, leaving a foot-long length of string hanging for each tie. Then cut the cylinders into sections with a saw or serrated knife.

Spread old newspapers on your work surface and put the can of melted wax on it. Have the Webelos scouts dip their paper sections into the wax, holding onto them with the long strings. Place the fire starters on other newspapers to dry. When using them, tear the edges slightly for faster ignition.

Have the Webelos scouts dip their paper sections into the wax, holding onto them with the long strings. Place the fire starters on other newspapers to dry. When using them, tear the edges slightly for faster ignition.

### Knot Games:

- One-Handed Overhead Knot – Drape an 18-inch length of rope over a contestant's wrist. Using just that hand, he is to tie an overhand knot as quickly as possible. The knot is considered tied when it is free of the contestant's arm.
- Giant Square Knot – Two Webelos scouts hold the free ends of a 10-foot length of rope in their right hands. Working together, they try to tie and tighten a square knot without letting go of their rope.

## Games:

### First Aid Kim's Game:

Equipment: Blanket or tarp; collection of 10 or more first aid items (gauze pads, bandages, splints, etc.); also 10 or more items not used in first aid (penny, photo, shoe, etc.).

Spread all items on the floor and cover with blanket or tarp. Group teams around the blanket, then remove cover for exactly one minute. Afterward, teams huddle separately and write down all first aid items they remember.

Scoring: Team with most complete list wins. Subtract one point for each non-first aid or absent item listed.

### Fireman's Drag Relay:

Preparation: Neckerchiefs

Participants divide into two teams. Half the members of each team are firemen; the other half are victims and are laying on their backs. On signal, the first fireman runs up to his victim, ties his wrists together with a neckerchief, and pulls him back to the starting line with the fireman's drag. He touches off the next fireman, who then rescues his "victim". First team to bring all their victims wins.



## Readyman Activity Badge – Required for Arrow of Light

---

### Requirements:

*Do All of These:*

1. With your parent, guardian, or Webelos den leader, complete the Courage Character Connection.
  - a. Know: Define the importance of each courage step. Be strong; be calm; be clear; be careful. Explain how memorizing the courage steps helps you to be ready.
  - b. Commit: Explain why it is hard to follow the courage steps in an emergency. Tell when you can use the courage steps in other situations (such as standing up to a bully, avoiding fights, being fair, not stealing or cheating when tempted, etc.)
  - c. Practice: Act out one of the requirements using these courage steps: be strong; be calm; be clear; be careful.
2. Explain what first aid is. Tell what you should do after an accident.
3. Explain how you can get help quickly if there is an emergency in your home. Make a "help list" of people or agencies that can help you if you need it. Post it near a phone or another place with easy access.
4. Demonstrate the Heimlich maneuver and tell when it is used.
5. Show what to do for these "hurry cases":
  - a. Serious bleeding
  - b. Stopped breathing
  - c. Internal poisoning
  - d. Heart attack
6. Show how to treat shock.
7. Show first aid for the following:
  - a. Cuts and scratches
  - b. Burns and scalds
  - c. Choking
  - d. Blisters on the hand and foot
  - e. Tick bites
  - f. Bites and stings of insects other than ticks
  - g. Poisonous snakebite
  - h. Nosebleed
  - i. Frostbite

j. Sunburn

8. Tell what steps must be taken for a safe swim with your Webelos den, pack, family, or other group. Explain the reasons for the buddy system.

*And Do Two of These:*

9. Explain six safety rules you should follow when "driving" a bicycle.
10. Explain the importance of wearing safety equipment when participating in sports activities (skating, skateboarding, etc.)
11. Make a home fire escape plan for your family.
12. Explain how to use each item in a first aid kit.
13. Tell where accidents are most likely to happen inside and around your home.
14. Explain six safety rules you should remember when riding in a car.
15. Attend a first aid demonstration at a Boy Scout troop meeting, a Red Cross center, or other community event or place.

### Suggested Activities:

- Ask one of the following to attend a den meeting and discuss their careers: doctor, nurse, police, paramedic, EMT, fireman, Red Cross instructor, school or community nurse, Urgent Care facility manager, hospital or emergency room worker. Or ask if you can visit them where they work.
- Arrange a behind-the-scenes tour of a parent's work to review the safety procedures and precautions used there. Do they have rules posted? Have fire drills? Have a first aid kit?
- Tour a restaurant, hotel, high-rise apartment building, hospital, church or other public place and ask the same questions.
- Inspect your den or pack meeting place. Plan steps for use in an emergency during a den meeting.
- Make a list of items which your family would need to be prepared for a storm, electricity outage, tornado, or other significant event. Make specialized lists of items that are seasonal. For example, during wintertime, you would need extra blankets, but you wouldn't need them during a severe thunderstorm in the summer. Prepare a shelter area in your house and store some of these items there. Tape your lists on the wall. Each season, review your specialized lists and add or remove items from your shelter. Be sure to check batteries and food supplies for freshness.
- Put together a first aid kit for your den.
- Make posters showing how and when home accidents are most likely to happen.
- Ask an off-duty local rescue squad or ambulance corps to demonstrate some first aid situations and techniques.
- Play "Readyman Squares" using the required knowledge as questions.

## Games:

### First Aid Kim's Game:

Equipment: Blanket or tarp; collection of 10 or more first aid items (gauze pads, bandages, splints, etc.); also 10 or more items not used in first aid (penny, photo, shoe, etc.).

Spread all items on the floor and cover with blanket or tarp. Group teams around the blanket, then remove cover for exactly one minute. Afterward, teams huddle separately and write down all first aid items they remember.

Scoring: Team with most complete list wins. Subtract one point for each non-first aid or absent item listed.

### Fireman's Drag Relay:

Preparation: Neckerchiefs

- Participants divide into two teams. Half the members of each team are firemen; the other half are victims and are laying on their backs. On signal, the first fireman runs up to his victim, ties his wrists together with a neckerchief, and pulls him back to the starting line with the fireman's drag. He touches off the next fireman, who then rescues his "victim". First team to bring all their victims wins.

# Southern New Jersey Council

## 2004 POW WOW

### KNOTS

#### **SAFETY FIRST**

*Rule #1 - Never tie anything to another person unless instructed by an adult.*

*Rule #2 – Never tie anything around your neck.*

#### **KNOT TEACHING TIPS**

**Demonstrate tying from the scout's perspective.** If you tie the knot as you learned to tie it, it will probably look backward to the scouts. Try tying it on a table while sitting so the boys can look over your shoulders to see you tie it from the same perspective. If facing the scouts, reverse the knot so they see it the same way as shown in printed examples.

**Teach knots in context.** Scouts will learn the knots better and remember them longer if they learn a practical use for them. Use examples like the square knot is the basic knot for tying their shoes. Use a bowline and two half hitches to bundle recycled newspapers. Have the boys make a list of knots they find in their homes.

**Practice makes perfect.** Even the best knotters will forget how to tie a knot if they don't practice and use the knots on a regular basis. Teaching knots will be a waste if the boys can't remember them when they need to tie something.

**Use the proper tools.** Having the right materials available will make teaching a lot easier.

**Knives-** "The sharper, the better!" Dull knives can cause injury. A sharp blade will cut materials easily and cleanly. Remember- have the scouts earn their Whittling Chips before they handle knives.

**Heat Source-** Use a disposable lighter or a butane fire starter for fusing the ends of synthetic ropes. Avoid matches, candles or any heat source that won't automatically go out if dropped. Have a fire bucket or fire extinguisher readily available.  
Needle nose pliers. These are extremely handy for removing tight knots.

**Fid or Marlinspike-** These are specialized tools for laying open the strands of rope or loosening knots. A philips screwdriver can be a substitute.

**First Aid Kit-** Sooner or later you'll need it.

**Rope selection-** Despite the temptation, don't buy the cheapest rope you can find. This usually is a white clothesline material which frays easily and the center core slips and bunches. Unless you are teaching splicing, don't select a three strand twisted rope. Is the whipping fails, they fray easily and become a mess. Select a synthetic braided utility line that doesn't have a core. This type can be easily fused and is easy to tie. Buy white if possible so that it can be color coded (see Teaching Aids).

**Teaching Aids-**

**Books-**There are a multitude of books on knots and the BSA have some of the best basic ones.

**Knot boards** are great because they show the finished and/or partial knot in three dimensions.

**Diagrams** can be enlarged from books so that a whole group can study them at one time. Color coding can be a great enhancement.

**Large scale aids-** Use the largest diameter rope available to demonstrate what you are teaching. This way the scouts see the rope instead of your fingers. Tip for teaching whipping- use a piece of 1"-2" diameter pipe or wood dowling as the rope and a piece of ¼" line as the whipping thread. This works great and the kids get a chance to try the big version before they tie the smaller vision.

**Wire-**Another aid is wire. A strand of 12 or 14 gauge Romex household electrical wire can be used to demonstrate an "exploded" version of a knot. By stripping of the insulation from part of the wire, you can give a contrast between two parts of a knot.

**Colored rope-** The use of different colored rope gives great visual contrast to the different parts of a knot. They also allow you to tell the scouts specific step by step instructions for tying knots. If colored rope is not available, use permanent magic markers to color the end portions of lines. If using one piece of line to demonstrate, color 3"-6" inches of each end with two different colors.

**Animation-** The internet has several great websites that have animated the scout knots. These will help you learn as well as teach the knots. See attached list.

**Field Tips-**

**Use the right knot for the Job.** There is nothing worse than thinking something is secure the finding the knot has slipped. Double check the knot under both slack and strain conditions. Use a slippery knot if you plan to remove the knot soon or in a hurry.

**More is NOT better.** Some feel the need to tie enough knots to use up the rest of the rope. This just slows the whole process. Either coil the excess or cut it off.

Leave a tail. Always leave enough line to work the knot, either tightening, retying or untying.

Coil and store carefully. This avoids a rat's nest especially if you need the line in a hurry.

## **MOST OF ALL- HAVE FUN WITH KNOTS**

**Jim Randall**  
**Pack and Troop 4**  
**(856) 467-5681**  
**JFSCOUTS@COMCAST.NET**

## **KNOT TYING WEBSITES**

[www.mistral.co.uk/42brghtn/knots/](http://www.mistral.co.uk/42brghtn/knots/)

[www.troop9.org/?s=knots/sbend/index](http://www.troop9.org/?s=knots/sbend/index)

[www.scouts.asn.au/knot\\_idx.html](http://www.scouts.asn.au/knot_idx.html)

[www.e-scoutcraft.com/misc/knot\\_board.html](http://www.e-scoutcraft.com/misc/knot_board.html)

[www.yesterdayschild.ca/scouts/knots.html](http://www.yesterdayschild.ca/scouts/knots.html)

[www.rubyfallsrocks.com/scouts/knots.htm](http://www.rubyfallsrocks.com/scouts/knots.htm)

# **CHARACTER AND ETHICS**

## **Activities That Achieve The Aims of Cub Scouting.**

### **The Purposes of Cub Scouting**

The purposes of Cub Scouting are to help families and community organizations serve boys by:

- **Character Development**
  - **Spiritual Growth**
  - **Good Citizenship**
  - **Sportsmanship**
- **Family Understanding**
- **Respectful Relationships**
- **Personal Achievement**
  - **Friendly Service**
  - **Fun and Adventure**
- **Preparation for Boy Scouts**



# Character Connection

When it comes to developing character, the complete person must be considered. Character development involves at least three critical areas:

**Thinking,  
Feeling,  
Behavior**

In the Cub Scouting program, using these three critical areas and relating them to values will be referred to as Character Connections.

Character Connections are used to connect a boy's thinking, feeling, and behavior to **Scouting's 12 Core Values**, which are:

- **Citizenship**
- **Compassion**
- **Cooperation**
- **Courage**
- **Faith**
- **Health and Fitness**
- **Honesty**
- **Perseverance**
- **Positive Attitude**
- **Resourcefulness**
- **Respect**
- **Responsibility**

You will teach your child values  
whether you intend to or not.

*PLBW*

# CUB SCOUT

## CHARACTER DEVELOPMENT

Since its origin, the program of the Boy Scouts of America has been an educational experience concerned with values. In 1910, the first Scouting activities were designed to build character, physical fitness, practical skills, and service. These elements were a part of the original Cub Scout program and continue to be part of Cub Scouting today.



Just as character development should extend into every aspect of a boy's life, so character development should extend into every aspect of Cub Scouting. Cub Scout leaders should strive to use Cub Scouting's **twelve core values** throughout all elements of the program: service projects, ceremonies, games, skits, songs, crafts, and all the other activities enjoyed at den and pack meetings.

Program support ideas can be found in Cub Scout Program Helps, in the Cub Scout Leader Book, and at your monthly roundtable meetings.



Character can be defined as the collection of core values possessed by an individual that leads to moral commitment and action.

Character development refers to the processes by which these core values are practiced.

## CUB SCOUTING'S 12 CORE VALUE

- 1. Citizenship:** Contributing service and showing responsibility to local, state, and national communities.
- 2. Compassion:** Having consideration and concern for the well-being of others.
- 3. Cooperation:** Working together with others toward a common goal.
- 4. Courage:** Doing what is right regardless of its difficulty or the consequences.
- 5. Faith:** Having inner strength and confidence based on our trust in a higher power.
- 6. Health and Fitness:** Being personally committed to care for our minds and bodies.
- 7. Honesty:** Telling the truth and being worthy of trust.
- 8. Perseverance:** Sticking with something and not giving up, even if it is difficult.
- 9. Positive Attitude:** Setting our minds to look for and find the best in all situations.
- 10. Resourcefulness:** Using human and other resources to their fullest.
- 11. Respect:** Showing regard for the worth of something or someone.
- 12. Responsibility:** Fulfilling our duty to take care of others and of ourselves.

- ✓ **Core values are the basis of good character development.**
- ✓ **Character must be broadly defined to include thinking, feeling, and behavior**
- ✓ **Core values should be promoted throughout all phases of life.**



# Character Connections

TM

**Character development** should not be viewed as something done occasionally as part of a separate program, or as part of only one area of life. For in reality, character development is a part of everything a Cub Scout does. Character development lessons can be found in every aspect of the Cub Scouting experience.

In an effort to take character development an integral part of Cub Scouting, the twelve core values are being integrated throughout the boys' handbooks and advancement program.

When it comes to developing character, the complete person must be considered. Character development involves at least three critical areas:

1. Know (thought),
2. Commit (feeling) and
3. Practice (behavior).

In Cub Scouting, addressing these three critical areas and relating them to values is referred to as **Character Connections**.

**Know:** Character development includes moral knowledge both awareness and reasoning. For example, children must understand what honesty means and they must be able to reason about and interpret each situation, and then decide how to apply the principles of honesty.

*What do I think or know about the core value? How does the context of this situation affect this core value? What are some historical, literary or religious examples representing the core value?*



**Commit:** Character development includes attention to moral motivation. Children must be committed to doing what they know is right. They must be able to understand the perspectives of others to consider how others feel, and to develop an active moral conscience.

*Why is this core value important? What makes living out this core value different? What will it take to live out this core value?*



**Practice:** Character development includes the development of moral habits through guided practice. Children need opportunities to practice the social and emotional skills necessary for doing what is right but difficult, and to experience the core values in their lives.

How can I act according to this core value? How do live out this core value? How can I practice this value at school, at home and with my friends?



## **The goals of the Cub Scout leader are:**

- ✓ **to seek out and maximize the many opportunities to incorporate character development**
- ✓ **to convince the young Cub Scout that character is important to the individual, to his family, community, country, world, and to God.**

# CUB SCOUT EXTRAS



## TABLE OF CONTENTS

Religious Awards and Emblems	3
Cub Scout Sports and Academics Program	4
BSA Family Program	7
BSA Crime Prevention Award	8
World Conservation Award	9
Conservation Good Turn Award	9
National Summertime Pack Award	10
Pack and Den Summer Activities	10
Pack Service Projects	11
Anniversary Month Activities	12
Cub Scout Camping Guidelines	13
Day Camp and Resident Camp	14
Blue and Gold Banquet	15
Special Events	19

### CORRECT PLACEMENT OF TEMPORARY INSIGNIA

All patches described in this section are considered temporary insignia. Only one such patch may be worn at a time. The patch is worn centered on the right pocket and must not exceed the dimension of the seams of the pocket, nor extend higher than the lowest tip of the pocket flap. It may either be sewn or suspended from under the flap attached to the button.

A Cub Scout may wear the **Progress Toward Rank or Webelos compass points emblem** or Webelos Scout suspended from the right pocket button in addition to sewn-on temporary insignia.

## RELIGIOUS AWARDS AND EMBLEMS

Duty to God is an integral part of the Cub Scout program. Every time a boy says the Cub Scout promise, he pledges to do his duty to God. Since its inception, the Boy Scouts of America has encouraged its members to be faithful in the practice of their religions. The Boy Scouts of America, however, does not define what constitutes belief in God or the practice of religion. That is up to the individual and his family.

Within the requirements for earning the Wolf, Bear, and Webelos Badges, each Cub Scout is given the option of earning the religious emblem of his own personal faith. Most of the major religious bodies in the United States have programs to recognize youth who demonstrate faith, observe the beliefs of the church, and give service.

- The religious emblems (*medals*) are NOT Scouting awards. They are earned through the boy's religious group. Boys work with a religious counselor and/or mentor, appointed by the church, on a set of age-appropriate requirements that may take a year or more to complete.
- When a boy may work on a religious emblem varies with religious denominations. Most may start work as soon as they join the pack. Some religious bodies, however, require the boy to achieve a certain rank or tenure before he can start work on the award. Some religious organizations allow a Boy to earn several levels of religious awards during his Cub Scout tenure.



A list of religious emblems available to Cub Scouts can be obtained from the Council Resource Center. Request A *Scout is Reverent*, No. 5-206A.

When a boy earns a religious emblem through his church, Scouting recognizes his achievement by presenting him with a square knot (silver knot on purpose background), worn centered above the left uniform pocket. This award may be worn on his Scouting uniform through adulthood. When a boy leaves Cub Scouting, a special Cub Scout device is pinned centered on the knot to signify it was earned in the Cub Scout program.



### AWARDS FOR ADULT LEADERS

Additional information on religious awards for youth and adults may also be obtained from:

P.R.A.Y. (*Programs of Religious Activities with Youth*)

8520 McKenzie Road

P. O. Box 6900

St. Louis, MO 63123

**1-800-933-PRAY**

There are also similar religious emblems for adult Scouters that are presented for outstanding service to boys through Scouting. Most of these are by nomination of the religious organization.



## CUB SCOUT SPORTS & ACADEMICS PROGRAM

The Cub Scout Sport and Academics program is an enrichment program that complements the existing Cub Scout program. The activities in Sports and Academic program give boys an opportunity to learn new skills, develop habits of good sportsmanship, expand their knowledge in fields of academic interest, and have FUN.

**The Cub Scout Sport and Academic Program is based on the following concepts:**

- ✓ Sports and Academics should supplement the existing Cub Scout advancement and recognition program - not replace it. The program is one part of Cub Scout; as are den meetings, pack meetings, or day camp.
- ✓ Participation is open to all levels of Cub Scouting - Tiger Cubs, Cub Scouts, and Webelos Scouts.
- ✓ Boys may participate in the program at home, in the den, in the pack, or in the community.
- ✓ Boys are encouraged to participate with an adult partner - preferably a family member/
- ✓ The focus of the program is sportsmanship and scholarship - not winning. The idea is to introduce the boy to a sport or academic subject and allow him to participate in it to the best of this ability.



### THE PACK'S RESPONSIBILITY IN SPORTS AND ACADEMICS

The flexibility of the Cub Scout Sports and Academics program allows each pack to determine how their unit will implement the program. Pack leadership may determine:

- ✓ What level of participation is appropriate for recognition.
- ✓ Ways in which individuals, the den, and the pack can be involved. During your annual pack-planning meeting, determine which subjects will complement your program plans, the school activity calendar or the community activity calendar.
- ✓ Definition of den or pack tournament.
- ✓ When and how recognition takes place
- ✓ How costs of the program are budgeted. Who pays for booklets and awards?
- ✓ How requirements are verified. Who will keep records of awards earned and presented?

### PACK RESOURCES FOR SPORTS AND ACADEMICS PROGRAM

Cub Scout Sports and Academics Leaders Guide (No. 34296)  
 Cub Scout Leader Book (No 33221)  
 Pamphlets for individual sports and academic topics  
 Den Recognition Report, Sports and Academics Awards (No 2167A)

## PARTICIPATION IN CUB SCOUT SPORTS AND ACADEMICS

There are two levels of involvement in the Cub Scout Sports and Academics program:

A boy earns a **BELT LOOP** by:

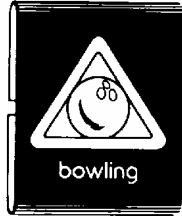

- ✓ **LEARNING** - Doing his best to learn about the activity as discussed in the corresponding booklet.
- ✓ **PARTICIPATING** - Participating in the sport or academic activity, through practice or play, in one of these places; in his den or pack; in an organized sports groups in his community (YMCA, *Little League, etc*); or on an individual/family basis.

Sports belt loops are silver in color, while Academics belt loops are gold. They may be worn with the age-appropriate uniform on the blue web Cub Scout belt. Webelos who have chosen to wear the Khaki uniform may still wear the blue Cub Scout belt to display belt loops they have earned.

After earning a belt loop in a subject area, a boy may earn a **SPORTS/ACADEMIC PIN** by:

- ✓ **Continuing to participate** in the activity at home, in his den or pack, or in the community.



### ACADEMIC & SPORTS LETTER

This is available to boys for displaying Academic and Sports pins that Tiger Cubs, Cub Scouts, and Webelos Scouts earn. The letter, representing "Cub Scouts," can be worn on a sweater or jacket, or displayed or framed. It does not go on the uniform. There are no specific requirements for earning the letter, as it is designed merely to display pins.

Medals come with blue and gold ribbons are available in gold, silver, and bronze. Pack leaders may choose to award medals to boys for special recognition in the program.

A trophy for the program is also available for presentation to boys, dens, or families at events such as pack or den tournaments. There are no specific requirements for the trophies.

The Participation Emblem is available to all boys and adults who participate in the Academics and Sports program. Individuals may purchase them, or packs may decide to award them to everyone involved.



## SPORT SUBJECTS

There are 24 Cub Scout Sports subjects available:

Archery*	Badminton	Baseball
Basketball	BB-Gun shooting*	Bicycling
Bowling	Fishing	Flag
Football	Golf	Gymnastics
Ice Skating	Marbles	Physical Fitness
Roller Skating	Snow Ski/Board	Soccer
Softball	Swimming	Table Tennis
Tennis	Ultimate	Volleyball



\*The BB Gun Shooting and Archery belt loops have specific qualification and are to be completed only under proper supervision *at approved district/council events*, such as Day Camp, with a qualified range officer present. This belt loop is cooper in color.

## ACADEMICS SUBJECTS

There are 17 Cub Scout Academic Subjects available:

Art	Astronomy	Chess
Citizenship	Collecting	Communicating
Computers	Geography	Geology
Heritages	Language & Culture	Music
Map & Compass	Mathematics	Science
Weather	Wildlife Conservation	



### SPECIAL NEEDS SCOUTING AND SPORTS AND ACADEMIC AWARDS -

Flexibility and individuality are key words to remember when adapting Cub Scout Academics and Sports for boys with disabilities. *Scouting for Youth with Learning Disabilities (No 33065)*, *Scouting for Youth with Emotional Disabilities (No. 32998A)*, and "Cub Scouts with Disabilities" in the Cub Scout Leader Book are important resources for packs and dens using the Cub Scouts Academics and Sports program.



## BSA FAMILY PROGRAM

The BSA Family Program is designed to help parents strengthen family ties. It is a natural outgrowth of the basic Cub Scouting program, of which family involvement has always been an integral part. All family members are encouraged to participate and may earn the BSA Family Award.

The purposes of the BSA Family program are:

1. To strengthen families.
2. To encourage family involvement in Scouting.

A Cub Scouting family may choose to participate in this program its own. Or, the pack may choose to introduce the program to families through an orientation.

### THE BSA FAMILY AWARD

A family must complete 10 activities within a 12-month period. The family chooses one activity in two topics in each of the following categories:

1. Learning Through Fun and Adventure.
2. Strengthening Family Relationship.
3. Developing Character.
4. Teaching Responsibility.
5. Handling Difficult Situations.



Family members may earn the BSA Family Award several times. A family may choose the same or different activities as they work on the award for another 12-month period.

### FAMILY ACTIVITY BOOK

This is the primary resource for the program. It is filled with suggested activities to enhance the children's personal development and enrich and strengthen the family.

The activity book is divided into the five categories. Each topic contains suggested activities for a family to do together. These activities could include going on field trips; telling stories; doing arts and crafts projects; playing games; participating in family discussions; or making lists, charts, and scrapbooks. Parents may use the ideas and activities to meet their own family's needs and interests.





## BSA CRIME PREVENTION AWARD

The BSA Crime Prevention Award is completed in two phases. In the first phase, families complete the required activities with their son. Addressing crime prevention through families is one of the most effective ways to combat the problem. Topics for discussion are outlines on the application. The second phases involves the completion of a unit-approved project with the family, den, pack, or community group.

Recognition that may be purchased includes a patch, lapel pin, pocket certificate and wall certificate.

### **PHASE 1 - YOUTH and FAMILY**

Complete activities from the Cub Scout handbook in which your son is working, as indicated below, and discuss how they relate to crime prevention in your family.

#### **FIRST GRADE**

*Tiger Cubs Handbook*

"Making My Family Special," Hold a family

Hold a meeting and discuss ideas from the

"Youth" section on the other side of the application form

"Where I Live," Discuss how your family can better understand community resources related to crime prevention.

#### **SECOND GRADE**

*Wolf Cub Scout Book*

"Know your Home and Community,"

Achievement 4

"Making Choices," Achievement 12

#### **THIRD GRADE**

*The Big Bear Cub Scout Book*

"Law Enforcement is a Big Job" - Achievement 7

"Be a Leader: - Achievement 24

Relate three of the requirements to Crime Prevention.

#### **FORTH-FIFTH GRADE**

*Webelos Scout Book*

"Citizen" - pages 83-101

"Family Member" - pages 147

Discuss items about drugs and crime, gangs on crime, graffiti and crime, peers and crimes.

### **PHASE 2 - YOUTH and UNIT**

Participate with your family, den, pack, or friends in a crime prevention project, either an original project or a project of a neighborhood - or community-based organization. (*Before beginning the project, have the unit leader approve your choice.*)

### **BSA CRIME PREVENTION AWARD RESOURCES**

No 23-169

Crime Prevention Unit Kit

No 13-011

Cub Scout Crime Prevention Award Application

## WORLD CONSERVATION AWARD

Cub Scouts and Webelos Scouts who have participated in either a den or pack conservation project and have completed certain requirements can earn the World Conservation Award. The colorful temporary patch is worn centered on the right shirt pocket of the uniform.

### WOLF REQUIREMENTS:

Complete achievement #7

Complete all arrow points in two of the following three electives:

#13 – Birds

#15 – Grow Something

#19 - Fishing

### BEAR REQUIREMENTS:

Complete achievement #5

Complete all arrow points in two of the following three electives:

#2 - Weather

#12 - Nature Crafts

#15 - Water & Soil Conservation

### WEBELOS SCOUT REQUIREMENTS:

Complete the following activity badges:

Forester

Naturalist

Outdoorsman

Participate in a den or pack conservation project in addition to the above.

**NOTE: This award is only earned once.**

## CONSERVATION GOOD TURN AWARD

The Conservation Good Turn is an opportunity for Cub Scout packs to join with conservation or environmental organizations (*local, state, federal or private*) to carry out conservation Good Turn in their communities.

The Cub Scout pack contacts a conservation agency and offers to carry out a Good Turn project.

The agency identifies a worthwhile and needed project that the unit can accomplish.

Working together in the local community, the unit and the agency plan the details and establish the date; time and location for carry out the project.

Cub Scout conservation projects should involve the entire Cub Scout pack, each den, adult leaders, and family members. Cub Scout and Webelos Scouts participating in the Conservation Good Turn may be present with a patch.

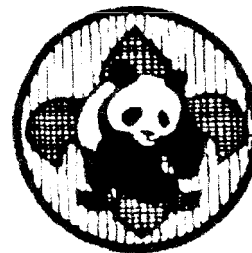

## NATIONAL SUMMERTIME PACK AWARD

Cub Scouting is a year-round program and all boys deserve such! Your pack can qualify for the National Summertime Pack Award by planning and conducting one pack activity per month in June, July, and August. Many parents have more time to be involved in the planning of events during these months, and pack activities will keep enthusiasm high among boys and their families. Pack recognition includes a certificate and a streamer for your pack flag.

Dens with an average attendance of at least half their members at each of the three summer pack events are eligible for a den participation ribbon to display on their den flag or den doodles.



Boys who participate in all three pack events are eligible to receive the National Summertime Pack Award pin, which is worn on the right pocket flap of the uniform. This is an individual recognition for boys, not adults.



Presentation of these awards at your September pack meeting can create an increased awareness and provide an incentive for greater attendance at next year's summertime event.

### PACK & DEN SUMMER ACTIVITIES

- |                         |                     |                       |
|-------------------------|---------------------|-----------------------|
| Obstacle Course         | Roller Skating      | Gold Miner Days       |
| Cub Scout Chefs         | Museum Visit        | Glider Derby          |
| Sailboat Regatta        | Kite Flying         | Pack Hike             |
| Watermelon Feed         | Cubmobile Derby     | Bowling               |
| Baseball Game           | National Collection | Clean-up Day          |
| Swimming Party          | Hike                | Horseback Riding      |
| Space Derby             | Backyard Carnival   | Visit State Park      |
| Pet Contest             | False Alarm Picnic  | Weiner Roast          |
| Cub Chili Supper        | Miniature Golf      | Sports Day            |
| Tours                   | Outdoor Circus      | Ice Cream Bonanza     |
| Nature Outing           | Raingutter Regatta  | Service Projects      |
| Flag Day Ceremony       | Bike Rodeo          | Pinewood Derby        |
| Ice Cream Social        | Bug Scavenger Hunt  | Treasure Hunt         |
| Day Camp                | Fishing Derby       | Den Cook-out          |
| Pack Family Overnighter | Family Picnic       | Corn Roast            |
| Attend Baseball Game    | Country Fair        | Gourd/pumpkin judging |
| Car Races               | Family Overnighter  | Sports Day            |
| Cake Auction            | Zoo Visit/Picnic    | Trail Blazing         |

## PACK SERVICE PROJECTS

Along the trail of Cub Scouting, boys promise to "help other people" and state, "a Cub Scout gives goodwill." These should not be mere words. Cub Scout packs should provide boys an opportunity to put these words into action. Conducting a pack service project for your chartered organization or the community is one of the optional requirements for achieving the Cub Scout Pack Quality Unit Award.

By organizing service projects, the pack "helps the Cub Scout grow" by giving boys the opportunity to reach out to a wider community and to recognize the importance of good citizenship. Your pack could select one or more service project to work on throughout the year. Thanksgiving and Christmas are common service project times of the year, but the need exist year-round. Collect food and clothing in your neighborhood to donate to a shelter for the homeless at other times of the year. Families also need warm weather clothing.

Most districts will provide an organized "Good Turn" project in which your pack can participate.

If not, here are some ideas:

- ✓ Send a "care" package to American troops.
- ✓ Help pack Red Cross Friendship boxes.
- ✓ Launch a community or neighborhood clean-up campaign.
- ✓ Make personal care kits for adult/children's shelters.
- ✓ Visit with elderly at a senior day care center.
- ✓ Build birdhouses to improve habitats at selected nature preserves.
- ✓ Organize a fingerprinting campaign in your school or chartered organization.
- ✓ Participate in a food drive.
- ✓ Plant and care for trees for your chartered partner, local park or senior citizen center.



Before beginning any service project, remember:

- ✓ KISMIF - Keep it simple, make it fun!
- ✓ Consider the age of the boys.
- ✓ Regardless of age, consider the maturity of the boys.
- ✓ Make sure you have sufficient leadership - at least two-deep.

When you are ready to do a project:

- ✓ Get the Cub Scouts involved in the decision-making. Have the pack committee pre-approve a few ideas and let the boys decide democratically.
- ✓ Make contact with the cooperating organization, if applicable, and get permission.
- ✓ Set a date well in advance and inform parents.
- ✓ Obtain signed permission slips from parents.



## ANNIVERSARY MONTH ACTIVITIES

### RELIGIOUS OBSERVANCES

The Boy Scouts of America designates the Sunday that falls before February 8 (Scouting *Anniversary Day*) as Scout Sunday. Each chartered organization or local church may, however, designate another specific date to celebrate that is more acceptable to them.

Cub Scout Packs are encouraged to promote attendance of their member - in uniform - to participate in religious services on Scout Sunday in their local church. If your pack is chartered by a religious organization, you might want to consider attending as a group. Discuss with the minister or rabbi the possibility of emphasizing the Scout's duty to God in his message. If he knows of your attendance plans well enough in advance, it may be possible to include Scouts in the service.

### UNIFORM DAY

This is an excellent opportunity for packs to make themselves known in the schools, a primary source of membership. Encourage all pack members to wear their uniform to school on Scouting's official birth date, February 8<sup>th</sup>.

### REPORT TO THE INSTITUTION

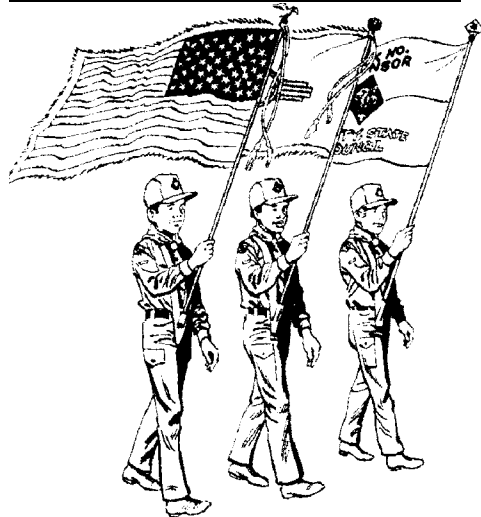

This would be a good time for a group of boys and adults to make a report to the chartering institution on the pack's program during the past year and its plans for the coming year. This activity can do much to strengthen the ties between the unit and the sponsoring organization.

Make the report before the entire membership of the organization, if possible - at a meeting of the governing board or as part of a special activity. Members of the chartered organization may be invited to pack activities so that the report is also made to the families of all youth members.

### DISPLAYS AND EXHIBITS

Packs can set up displays, exhibits, or live demonstrations to show the community what Scouting is all about. This can be done at a local library, youth center, PTA meeting, shopping center, or wherever your Scouts can "strut their stuff."

## CUB SCOUT CAMPING GUIDELINES

Cub Scouting and the out-of-doors - winning combination for a successful pack program! The Cub Scout outdoor program is designed to provide boys and their families with experiences that are an ever-increasing challenge as they progress through the Cub Scout program. Packs in the Southern NJ Council are encouraged to make overnight camping experiences a part of their annual program plan according to the following guidelines:



**PACK OVERNIGHTERS** - are overnight camping events that are planned, organized, and run by the members of an individual pack.

- ✓ Conducted at Camp Grice, Pine hill Scout Reservation, Roosevelt Scout Reservation or a council approved location (file a Local Tour Permit).
- ✓ All pack members (including Tiger Cubs) and family members may attend. Each child should be under the supervision of his/her own parent or guardian. \*
- ✓ One adult from the pack, who will attend and give leadership to the pack overnighter, must complete Basic Adult Leader Outdoor Orientation (BALOO).

**COUNCIL-ORGANIZED FAMILY CAMPING** - is a fee-based overnight camping event for which the council provides staffing, food service, and program.

- ✓ Conducted at Camp Grice, Pine hill Scout Reservation, Roosevelt Scout Reservation
- ✓ Packs, dens, or individual families, including Tiger Cub families may make reservations.
- ✓ All family members may attend. Each child should be under the supervision of his/her parent or guardians. \*
- ✓ Tiger Cubs may camp in this type of environment.

**CUB SCOUT/WEBELOS SCOUT RESIDENT CAMP** - is a three-day, two-night summertime program organized by the council.

- ✓ Conducted at Pine Hill Scout Reservation.
- ✓ Packs, dens, or individual families may make reservations.
- ✓ Boys who transition to a Wolf or Bear den at the end of the school year should register for Cub Scout Resident Camp. Boys who transition to a first-year or second-year Webelos den at the end of the school year should register for Webelos Scout Resident Camp.

**WEBELOS DEN OVERNIGHT CAMPING**

- ✓ Conducted by Webelos den leadership at a council camp (make reservation through the appropriate council office) or a council-approved site (In either case - file Local Tour Permit).
- ✓ Webelos dens may reserve council camping facilities at Camp Grice, Pine Hill Scout Reservation, Roosevelt Scout Reservation.
- ✓ Webelos den are encouraged to camp with troops, but should do so only at times when the den is the focus of the troop activity. Webelos Scout dens should not spend the night at Boy Scout-based events such as camporees.
- ✓ Each Webelos Scout should be under the supervision of a specific adult, in most cases his parent or guardian, even when participating in overnight activities with a troop. \*

**NOTES:**

**Tiger Cub and Cub Scout dens are not authorized to camp as a den unit except for resident camp or a council-organized family camping event.**

**It is the intent of Southern NJ Council that Cub Scout camping activities have a high degree of parental involvement.**

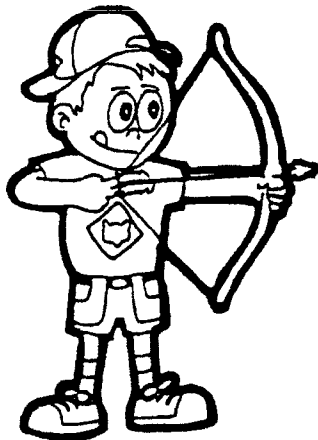
**DAY CAMP AND RESIDENT CAMP**

Day Camp, a weeklong summertime experience available for all registered Cub Scouts, is conducted on the district level. The camp is directed and staffed by volunteers just like you who put in a little extra time for some special training. Boys typically spend the day in activities such as making crafts, learning outdoor and nature skills, archery, BB-gun shooting, and playing Cub Scout games.

Specific details on the Day Camp conducted by your district are available at your district Roundtable or from your District Executive.

See Guide to Safe Scouting ([www.scouting.org/pubs/gss](http://www.scouting.org/pubs/gss)) and the latest edition of the *Cub Scout Leader Book* for further information on Cub Scout camping policies and guidelines.

## BLUE AND GOLD BANQUET

Each year in February Boy Scouts of America celebrates its anniversary. On February 8, 1910, William D. Boyce, based on the program started in England by Robert Stephenson Smyth Baden Powell founded BSA. Twenty years later, in 1930, the Cub Scout program began in the United States.

Add during the month of February, Scouting organizations across the United States hold special activities, service projects, dinners, and programs commemorating the anniversary of Boy Scouts of America. It is an ideal time to spotlight individual units, as well as the entire Cub Scout program, to the chartered organization, the schools that our Cub Scouts attend, and the community as a whole.

### WHAT IS A BLUE AND GOLD BANQUET?

A Blue and Gold Banquet is really a celebration dinner for the pack to say "Happy Birthday" to Cub Scouting. The banquets are family affairs and may be held on the usual pack meeting night or as a special event. Blue and Gold Banquet celebrations combine the principles of Scouting with family participation. Dens are seated together to encourage strengthening of den spirit and family relationships.

Blue and Gold Banquets are a tradition of Cub Scout packs across the country during the month of February. The big celebration gets its name from the Cub Scout colors.

### WHAT HAPPENS AT A BLUE AND GOLD BANQUET?

The boys, their families, and the guests enjoy a great dinner; see the boys and leaders of the pack receive awards, and enjoy the special entertainment.

In planning the banquet program, remember that it must appeal to boys as well as adults. There is no set rule to follow for a Blue and Gold program. It can be similar to a regular monthly pack meeting with songs, skits, stunts, and awards - or it can be something different and special such as a magician, puppet show, group of singers, or a special guest speaker. Some packs use a short slide presentation on Scouting in general or slides of specific pack activities from the past year.

Your Blue and Gold program should be adjusted to fit your pack's particular needs. If you plan to bring in an outside program, such as a magician or puppet show, you may not have time for every den to perform. Try to limit the total program time to an hour-and-a half.

Keep the program moving to hold the interest of the audience. Make it colorful with the use of props and costumes, as appropriate.



**The following is a suggested agenda for the Banquet program:**

- ✓ Gathering Period
- ✓ Opening Ceremony
- ✓ Invocation
- ✓ Dinner
- ✓ Songs
- ✓ Welcome & Introduction of Special Guests
- ✓ Greeting from Charter Org Head
- ✓ Den Skits and Stunts
- ✓ Webelos Demonstartions
- ✓ Advancement Awards Ceremony
- ✓ Recognition of Leaders

**WHO IS RESPONSIBLE FOR ORGANIZING THE BLUE AND GOLD BANQUET?**

To be successful, the Blue and Gold Banquet should be planned well in advance. The pack committee should select a banquet chairman several months in advance. This person recruits assistants (*unless already appointed by the pack committee*) to carry out responsibilities. The Blue and Gold Committee should try to involve as many parents as possible. Ask for help from each den. Try to avoid involving the den leaders with any additional responsibilities. They will be busy working with their dens.

**The Blue and Gold Banquet Committee is responsible for these things:**

1. Set the date and time of the banquet. Many packs hold this on the regular pack meeting night. Others prefer a weekend.
2. Check with the pack treasurer on your budget for the banquet. The amount of funds available will influence many of your decisions.
3. Decide on a meal-serving plan.

**POTLUCK** - Each family brings a dish to share with the pack or den group. Families or dens furnish their own plates, utensils, cups, etc.

**FOOD COMMITTEE** - If a kitchen is available, the pack may wish to buy the food, prepare it, and divide the cost among families (*if not included in the pack budget*).

**CATERED** - An outside organization or restaurant brings the food already prepared or the pack holds their banquet at a cafeteria or restaurant.

**COMBINATION OF THE ABOVE** - You might want to have the meat catered and the rest of the meal potluck. There is no right or wrong way to plan the meal. Do what suits the needs of your pack.

4. Secure an adequate facility at least six weeks in advance. This could be a school cafeteria, church meeting room, restaurant, etc. Consider these things when choosing a facility:

Rental Fee (if any)	Rest Room and coatroom
Seating capacity	facilities
Parking space	Special items; PA system,
Kitchen available (if <i>needed</i> )	etc.

**The Blue and Gold Banquet Committee is responsible for these things, too:**

5. Select a theme for the banquet. You may use the monthly theme recommended in Cub Scout and Webelos Scout Program Helps or choose a theme of your own. Besides adding to the festivity, it will be easier to plan the program and decorations if there is a theme for the evening.
6. Plan the format of the program and recruit someone to handle each item on the program. Choose a master of ceremonies.
7. Send written invitations to guests.
8. Prepare a written program to give out at the banquet.
9. Select a Welcoming Committee to greet people as they arrive.
10. Inform all pack families of the plans.
11. Arrange for a clean-up crew.

Not every member of the Banquet Committee needs to be involved in all aspects of the banquet. Organize SUBCOMMITTEES to handle the various areas, such as:

- ✓ Physical Arrangements Subcommittee
- ✓ Food Subcommittee
- ✓ Program Subcommittee
- ✓ Decoration Subcommittee

**WHO IS INVITED TO A BLUE AND GOLD BANQUET?**

Invitations to the Blue and Gold Banquet are usually sent to every pack family and to special guests. Boys can make the invitations at den meetings and take them home to their families. Invitations to special guests should be mailed.

Special guests to be invited might include:

District Executive and family	Former Cubmaster and spouse
Unite Commissioner and family	School principal and spouse
Chartered Organization Representative	Pack alumni
Head of the chartered organization	PTA president and spouse
Minister or rabbi	Den Chief

If there is no head table, or if there are too many guests to be seated at the head table, then it is a good idea to seat guests with dens. They usually like to be where the action is anyway! Be sure to let dens know in advance how many guests to expect, and who, so they can make the necessary table decorations, place cards, etc.

**WHAT IS THE DEN'S RESPONSIBILITY AT A BLUE AND GOLD BANQUET?**

Much planning goes into the banquet by everyone, and the dens are no exception. Prior to the banquet, the boys spend much of their time in February den meetings working on decorations for their den's tables. These decorations may include:

- |              |              |
|--------------|--------------|
| Placemats    | Napkin rings |
| Centerpieces | Nametags     |
| Place cards  | Favors       |

Decorations may be as elaborate or as simple as you wish. You do not have to have all of these items, but you will want enough to make a colorful display. The *Cub Scout Leader How-to Book* is a good resource for decoration ideas.

The den will likely be responsible for making invitations for family members. Each den may also be called upon to help with one part of the banquet program, such as opening ceremony, closing ceremony, a song, or a skit.

**CUB SCOUT FAVOR**

Use yellow cellophane-wrapped lollipop. Cut cap and neckerchief from construction paper and draw markings with crayon or marking pen. Use clay or wood block for base.

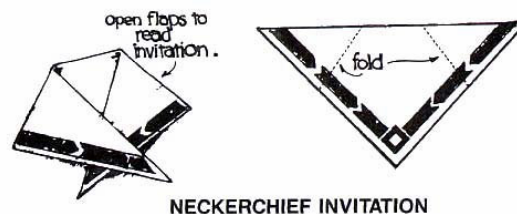

Cut triangle from yellow construction paper. Outline with blue marking pen and write date, time, and place of banquet. Fold as shown.

**NECKERCHIEF INVITATION**

*Material: Yellow construction paper, pens or fine line markers.*

Cut paper as shown.

Write the information such as TIME: PLACE:  
DATE: - on the inside of the neckerchief

On the outside flaps you can write Blue and Gold Banquet, on one side and on the other write Den#

Fold the invitation; draw lines along the bottom as shown.

## SPECIAL EVENTS

Special activities are the spark that makes your pack program shine. The extra effort that goes into planning these events will be well worth the effort as you watch the enthusiasm grow. Not only in the boys but within their families. Parents want to be involved when activities are planned that are exciting and fun. Recruiting becomes easier when a Cub Scout tells his friends about the fun things he is doing in his Cub Scout Pack.

The three special events most often utilized by packs are:

- ✓ Pinewood Derby - wooden model cars raced on a gravity-powered track.
- ✓ Raingutter Regatta - model boats in a raingutter, propelled by boys' own wind power.
- ✓ Space Derby - miniature rockets propelled by rubber bands along a monofilament line.

Kits for preparing the models for each of these derbies are available from your local Scout shop. Information on planning and organizing these events can be found in: *Cub Scout Grand Prix Pinewood Derby Guidebook* - this publication also includes the Raingutter Regatta and Space Derby. *Cub Scout Leader How-to Book*

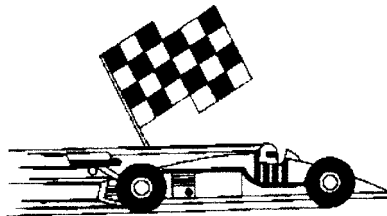

These are not the only special events that your pack can put on the calendar, however. Other tried and true pack activities that you may want to check out in the *Cub Scout Leader How-to Book* include:

Kite Derby	Fishing Derby	Cubmobile
Derby	All-Derby Race Day	Autumn Harvest Festival
Bicycle Safety Day	Conservation Day	Disabilities Awareness Day
Water Carnival	Cub Scout Field Day	
Summer Celebration	Welcome to the Midway	Family Cake Bake
Pack Picnic	Western Rodeo Roundup and Pioneer Day	

But don't stop with what you find in a book! Adapt some of these ideas to the monthly Cub Scout theme. Some of the best pack activities come from the imaginations of leaders and boys.



# **PURPOSES OF CUB SCOUTING**

- INFLUENCE THE DEVELOPMENT OF CHARACTER AND ENCOURAGE SPIRITUAL GROWTH
- DEVELOP HABITS OF GOOD CITIZENSHIP
- ENCOURAGE GOOD SPORTSMANSHIP AND PRIDE IN GROWING STRONG IN MIND AND BODY
- IMPROVE UNDERSTANDING WITHIN THE FAMILY
- STRENGTHEN THE ABILITY TO GET ALONG WITH OTHER BOYS AND RESPECT OTHER PEOPLE
- FOSTER A SENSE OF PERSONAL ACHIEVEMENT BY DEVELOPING NEW SKILLS AND INTERESTS
- SHOW HOW TO BE HELPFUL AND DO ONE'S BEST
- **PROVIDE FUN AND EXCITING NEW THINGS TO DO**
- PREPARE THEM TO BE BOY SCOUTS

# CUB SCOUT BASICS



## TABLE OF CONTENTS

The Organization of Scouting	2
The Purposes of Cub Scouting	5
Character Development	6
Cub Scout Leader Training	7
Cub Scout Leader Recognition Plan	10
Cub Scout Themes	10
Family Involvement	11

Welcome to the challenges and opportunities, joys and satisfactions that will be yours as a Cub Scout leader, guiding and influencing the lives of boys. By making the commitment to serve as a leader, you have joined the ranks of adult leaders in packs around the country who are giving time, ability, enthusiasm and energy to build a better future for our nation. As you give leadership in Cub Scouting, you help enrich the lives of boys and make a difference in the kind of men they will become. An exciting and rewarding experience lies ahead of you.

All leaders bring to Cub Scouts their own talents and skills, their own backgrounds and interest. Your key to being an effective leader is to use your own abilities and interest, along with what you learn about Cub Scouting, to plan and conduct the best possible program for the boys.

A multitude of resources are available for your use. This Pow Wow book will help guide you to those BSA resources that can give you additional information in specific areas. There are also many people who are interested in helping you be successful in your Cub Scouting job. Training opportunities are available so that you may continue to grow in effective leadership.

Again, we welcome you to the worldwide brotherhood of Scouting as together we work to accomplish the mission of Southern NJ Council.

**"LEADING YOUTH TO LIFELONG VALUES, SERVICE, AND  
ACHIEVEMENT"**

## THE ORGANIZATION OF SCOUTING



Welcome to Cub Scouting! When you joined the Boy Scouts of America, you joined more than a pack. The den and pack to which you belong are just the beginning of the Scouting organization structure. Boy Scouts of America is part of a world brotherhood of Scouting.

### BSA NATIONAL HEADQUARTERS

The Boy Scouts of America operates under a Federal charter from the U.S. Congress, which was granted in 1916. The charter calls for the Boy Scouts of America "to promote, through organization and cooperation with other agencies, the ability of boys to do things for themselves and others, to train them in Scout craft, and to teach them patriotism, courage, self-reliance, and kindred virtues..." The national organization makes available to members for purchase such things as uniforms and insignia, equipment, literature, program material, training material, and other important items. Scouting and Boys' Life magazines are provided as program aids and a method of keeping leaders informed and updated on the Scouting program.



**The National Headquarters of BSA is located at**  
 1325 West Walnut Hill Lane  
 P.O. Box 152079  
 Irving, TX 75015-2079



The National Cub Scout Committee administers Cub Scouting, which is part of the National Executive Board of the Boy Scouts of America. This National Cub Scout Committee is composed of volunteer Scouters like you.

### NORTHEAST REGION

Boy Scouts of America is subdivided into four regions - Northeast, Central, Southern, and Western. Each of the regions has a Cub Scout Committee headed by the Regional Cub Scout Chairman. Southern NJ Council is part of the Northeast Region.

*The Northeast Region serves more than 1,000,000 Scouts 150,000 adults across the northeastern United States, Puerto Rico, the US Virgin Islands, and the Transatlantic Council spanning across the globe.*



**SOUTHERN NEW JERSEY COUNCIL**

A council is an association of voluntary citizens who implement the Scouting Program within a specific boundary, providing service, leadership, management, and directions to organizations in their area using the Scouting Program. The Southern NJ Council is one of the larger of more than 330 Boy Scout Councils nationwide and serves over 15,000 youths and nearly 5000 adults in the southern five counties of New Jersey. These counties are Camden, Cape May, Cumberland, Gloucester and Salem. We, also serve a small portion of Atlantic County.

Southern NJ Council, BSA  
4468 Main Road  
Millville, NJ 08332

(856) 327-1700  
[www.snjscouting.org](http://www.snjscouting.org)

**THE DISTRICT**

The council is divided geographically into districts. The council through a volunteer district committee and commissioner staff carries out the supervision of Scouting in each district. The purpose of your district is to work with chartered organizations to organize and support successful units. This support includes:

- Training adult leaders
- Planning district activities
- Obtaining financial support
- Providing commissioner service

With effective district support, more and more youth members receive a better Scouting program as both units and leaders succeed in achieving Scouting's aim.

The Southern NJ Council is divided into 5 geographic districts: Cooper and Big Timber serving Camden County, Old Colony serving Gloucester and most of Salem county, Cumberland serving most of Cumberland County and portions of Atlantic and Salem Counties, and BaySea serving Cape May and a portion of Cumberland County. The purpose is to organize, support and maintain quality Scouting units in their area communities. The districts support the units by offering Adult Leader Training at Roundtables and Cub Scout Leader Basic Training. Districts, also, offer activity programs such as Day Camps, Pushmobile, and Webelos overnighter camping.

Most of the other packs and leaders that you will come into frequent contact with are those within your district. The districts, including Roundtable and Cub Scout Leader Basic Training, conduct many adult leadership trainings. Activity programs such as Day Camp, Webelos Woods, and Cub-o-rees are also administered on the district level.

Every district has a full-time Scouting professional, called the District Executive (DE), assigned to that geographical area. He or she is employed by the council and works under the direction of the council professionals. The DE is a trained professional who advises, coaches, and helps prepare volunteers for decisions to be made within the district. Recruiting, training, and motivating volunteers are the key to their success.

The district has assigned a volunteer Scouter to your pack, a Unit Commissioner, to assist your unit with advice and give moral support on pack issues. Your pack should work closely with your unit commissioner during the annual recharter period.

**THE CHARTERED ORGANIZATION**

Every Cub Scout Pack belongs to an organization having interests similar to the Boy Scouts of America. This may be a school, church, community organization, or group of interested citizens, which is chartered by the Boy Scouts of America to use the Scouting program. The Chartered Organization Representative (COR) is a member of both the pack and the chartered organization. This person is the liaison between the pack and the organization.

For more information on the relationship between the chartered organization and the pack, as well as the role of the Chartered Organization Representative, see the Cub Scout *Leader Book*.

**THE PACK**

The pack is a group made up of several dens - Tiger Cub, Cub Scout, and Webelos Scout dens. The pack includes not only the boys in the dens but also their families and leaders.

Important to the successful operation of the pack is the pack committee, a group of adults who manage such things as record keeping, finances, leadership, training, and registration.

The pack committee must contain at least three members; Committee Chairman

Two (2) members of the committee

Chartered Organization Representative (who may serve in the capacity of chairman or committee member, if needed)

Pack rosters also require these leadership positions: Cubmaster

At least one den leader, if 1<sup>st</sup>, 2<sup>nd</sup>, or 3<sup>rd</sup> grade boys are registered.

At least one Webelos den leader, if 4th or 5th grade boys are registered.

## THE PURPOSES OF CUB SCOUTING

Since 1930, the BSA has helped younger boys through Cub Scouting. Cub Scouting (*including Tiger Cubs*) is a yearlong family-oriented part of the BSA program designed for boys who are in first through fifth grades. Parents, leaders and organizations work together to achieve the 10 purposes of Cub Scouting.

1. Character Development
2. Spiritual Growth
3. Good Citizenship
4. Sportsmanship and Fitness
5. Family Understanding
6. Respectful Relationships
7. Personal Achievement
8. Friendly Service
9. Fun and Adventure
10. Preparation for Boy Scouts

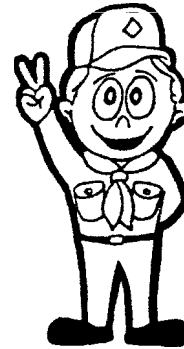

All the activities leaders plan and boys enjoy should relate to one or more of these purposes. These purposes help us achieve the overall aims of the BSA of Character Development, Citizenship Training, and Personal Fitness.

## THE METHODS OF CUB SCOUTING

Cub Scouting uses seven specific methods to achieve Scouting's aims of helping boys and young adults build character, train in the responsibilities of citizenship, and develop personal fitness. These methods are incorporated into all aspects of the program. Through these methods, Cub Scouting happens in the lives of boys and their families.



1. The Ideals
2. The Den
3. Advancement
4. Family Involvement
5. Activities
6. Home and Neighborhood Centered
7. The Uniform



## CHARACTER DEVELOPMENT

Since its origin, the Scouting program has been an educational experience concerned with values. In 1910, the first Scouting activities were designed to build character, physical fitness, practical skills, and service. All of these elements remain part of Cub Scouting today. As Cub Scouting has progressed through the years, the importance of making good decisions based on sound values has been integral and steadfast.

Character can be defined as the collection of core values possessed by an individual that lead to principled moral commitment and action. Character development refers to the processes by which these values are learned and practiced.



In general, three basic principles underlie character development:

**Core values are the basis of good character development.  
In helping boys develop character, Cub Scouting promotes 12 core values.**

- |                       |                      |
|-----------------------|----------------------|
| 1. CITIZENSHIP        | 7. HONESTY           |
| 2. COMPASSION         | 8. PERSEVERANCE      |
| 3. COOPERATION        | 9. POSITIVE ATTITUDE |
| 4. COURAGE            | 10. RESOURCEFULNESS  |
| 5. FAITH              | 11. RESPECT          |
| 6. HEALTH and FITNESS | 12. RESPONSIBILITY   |

These values are at the core of what it means to be involved in Scouting. In Cub Scouting, character development defines the core values and requires that we discuss them and try to make them an active part of the language and culture of the Cub Scout.

**Character must be broadly defined too include thinking (the head), feeling (the heart), and behavior (the hand).**

It is not enough to memorize words and slogans. Cub Scouts must learn to use their reason when evaluating competing values. They must be committed and have the skills necessary to act on their convictions despite peer and worldly pressures.

**Core values should be promoted throughout all phases of life.**

The character development program will challenge Cub Scouts to consider the core values from the perspective of six general areas:

**GOD**

**COMMUNITY**

**WORLD**

**FAMILY**

**COUNTRY**

**SELF**

The twelve core values are interconnected and interdependent. No one value is more important than another. The goal is not simply that Cub Scouts would know the values but that they would act in accordance with them in their lives.



## CUB SCOUT LEADER TRAINING

Every Cub Scout deserves a trained, qualified leader who is knowledgeable about the Cub Scout program. Training helps leaders understand the aims and purposes of the Scouting program and improves the quality of the program delivered to the boys.

Boy Scouts of America provides a continuum of training for its adult leaders to not only get them started in the right direction, but to keep leaders up to date on the program and to help them continually acquire new skills that will help them deliver a better program to the boys. The Cub Scout training plan includes four levels.

- Fast Start Training
- Supplemental Training
- Basic Leader Training
- Advanced Training

To qualify for the Cub Scout Pack Quality Unit Award, the Cubmaster and at least 50 percent of den leaders and Webelos den leaders must complete Fast Start and basic training for their current position. The pack must also have one or more registered, trained, and active assistant Cubmasters.

### FAST START TRAINING

When new leaders are selected in Cub Scouting, it is essential that they receive immediate information that will help them get started. As the first step in the training continuum, Fast Start Training is meant to provide all the information and resources for new leaders to conduct their first meeting, along with guidance for the meetings that follow. Fast Start is a short, video-based training program designed to provide specific meeting planning information related to the leader's volunteer position. Each video demonstrates actual meetings that new leaders may use as their own first meetings.

### BASIC LEADER TRAINING

Basic Leader Training is designed to give position related information to all adult leaders in Cub Scouting. Building on the foundation established in Fast Start Training, Basic Leader Training goes into greater detail. Basic Leader Training has two parts.



New Leader Essential is for all new leaders. It highlights the values, aims, history, funding, and methods of the Scouting program. Once completed, it need not be taken again, even if the leader moves to a different position or program level.

Leader Specific Training gives a leader the knowledge and skills needed for a specific position. Leader Specific Training is available for the following positions in Cub Scouting.

- Cubmaster and Assistant
- Pack Committee Members
- Tiger Cub Leader
- Cub Scout Den Leader and Assistant
- Webelos Den Leader

**SUPPLEMENTAL TRAINING**

Supplemental training includes a variety of training courses given on a district, council, and national basis. They are designed to provide Cub Scout leaders with additional information on specific areas of Cub Scouting.

**UNIT LEADERSHIP ENHANCEMENTS**

This training takes place within the pack and is conducted by a member of the pack leadership team as a part of the monthly pack leaders' meeting. Enhancements are short training discussions intended to help leaders be better prepared to deliver a quality Cub Scouting program to their boys. (*Outlines for these sessions may be found in the Cub Scout Leader Book*).

**ROUNDTABLE**

Cub Scout Leader Roundtable is "continuing education" held monthly on a district basis. District volunteers lead this lively training, which includes songs, skits, ceremonies, and other activities related to the Cub Scout theme and Webelos activity badges for the following month. It is an excellent time to interact with other Cub Scout leaders, sharing ideas for activities and events.

**WEBELOS LEADER OUTDOOR TRAINING**

This training does not cover extensive outdoor skills, but Webelos den leaders get information and hands-on practice in the outdoor skills needed to work with Webelos Scouts. They will learn how to use the resources of their natural environment. Conducted on the district level, this training may involve an overnight camping experience

**BALOO - BASIC ADULT LEADER OUTDOOR ORIENTATION (BALOO)**

This is a one day training event that introduces parents and leaders to the skills needed to plan and conduct pack outdoor activities, particular pack camping. BALOO includes information on:

- Preparations
- Site selection
- Parent involvement
- Health and Safety
- Equipment
- Feeding
- Introduction to outdoor skills

This training is required for any adult who is in charge of planning a pack campout.

**YOUTH PROTECTION TRAINING**

The problem of child abuse has become one of the most significant problems facing our nation. Boy Scouts of America has a training program for adult leaders and parents based upon the policies and procedures BSA has developed to ensure that all volunteer leaders and parents are aware of the problem and that Scouting provides a safe environment for all participants.

This course may be taken at home on-line. You start at our website, [www.snjscouting.org](http://www.snjscouting.org)

It is, also, given by Certified Youth Protection instructors administer Youth Protection Training on a district level in Southern NJ Council. This training may be held in conjunction with New Leader Essentials. Other "stand-alone" training sessions are conducted when requested.

**POW WOW**

Cub Scout Leader Pow Wow is an annual learning extravaganza conducted by the council. It is a daylong series of workshops, chosen individually by the leader, to increase his knowledge and skills in his particular area of the Cub Scout program.

**UNIVERSITY OF SCOUTING**

Like Pow Wow, University of Scouting is a daylong series of workshops, chosen individually by the leader, to help him plan a better program for the boys he works with. University of Scouting, however is not exclusive to Cub Scouting and includes classes for leaders working in all program areas. *Although not offered by Southern NJ Council, some of our neighboring councils offer this program.*

**TRAINER DEVELOPMENT CONFERENCE**

The Trainer Development Conference is designed to provide all trainers with enhanced contemporary skills for delivering quality training in their areas of responsibility. The council usually offers it as a one-day conference. Most of the sessions in the conference not only demonstrate good training methods but also give participants an opportunity to interact and in many cases actually practice what they have learned.

**PHILMONT TRAINING CENTER**

Boy Scouts of America's national training center for volunteers is located at Philmont Training Center in Cimarron, New Mexico, adjacent to base 1 •- camp for Philmont Scout Ranch, Boy Scouting's High Adventure Base. Conferences specific to Cub Scouting are held during the summer in topics such as "Webelos Scout Program," Quality Pack Program, "Strictly for Cubmasters," and other areas relative to district and council activities.

**ADVANCED TRAINING**

**WOOD BADGE**

Wood badge is advanced training in leadership skills for all adults in BSA programs. This advanced training is presented in two parts:



- An advanced learning experience presented over two long (threeday) weekends or as a weeklong course.
- An application phase of several months during which the leaders apply the specific skill they have learned at Wood Badge to their Scouting responsibilities.

## CUB SCOUT LEADER RECOGNITION PLAN

Cub Scout Leader Recognition Plan provides recognition for trained leaders who produce quality programs in the dens and pack that they serve. There are five awards available in the Cub Scout Program.:

- **CUBMASTER AWARD**
- **CUB SCOUTER AWARD**
- **TIGER CUB DEN LEADER AWARD**
- **CUB SCOUT DEN LEADER AWARD**
- **WEBELOS DEN LEADER AWARD**

To qualify for these awards, leaders must meet requirements in these areas:

TRAINING

TENURE

PERFORMANCE

*Complete requirements for each of these awards may be found in the Cub Scout Leader book*

## CUB SCOUT THEMES

Cub Scouting's recommended planning system is based on themes, one for each month of the year. Activities in Tiger dens, Wolf dens, Bear dens, and the pack meeting should center on this monthly theme. Webelos Scouts work on activity pins at their weekly den meetings and give a demonstration of what they learned at the pack meeting.

Themes help achieve the purposes of Cub Scouting. They keep the dens active, vigorous, and working on meaningful projects during the month. They help assure a well-balanced program in the den program activities. They assure a well-planned, more interesting pack meeting as the climax of the month.

	2004	2005
JANUARY	Home Alone	Cub Scouts Spread the News
FEBRUARY	Fiesta!	It's a Scouting Celebration
MARCH	Walk in My Shoes	Invention Convention
APRIL	Cubervation	Waterways of the U.S.A.
MAY	My Home State	Pet Pals
JUNE	Cub Rock	Destination: Parks
JULY	Fin Fun	Play Ball!
AUGUST	Scouting in the Midway	Campfire Tales and Traditions
SEPTEMBER	Time in a Capsule	Cub Scout Round-up
OCTOBER	It's a Circus of Stars	To the Rescue
NOVEMBER	Cub Scout Collectors	My Family Tree
DECEMBER	Holiday Food Fare	Faith, Hope and Charity

## FAMILY INVOLVEMENT

While many will say that there is a movement away from family unity in our country today, the Scouting movement still believes very strongly that close family relationships greatly benefit individuals and our country. It is to our benefit as volunteer leaders to interest the disinterested, bring out the shy and the reluctant, utilize wasted talents, and channel the enthusiasm of the parents and families of our Cub Scouts. Family participation is essential to the success of the Cub Scout program. Leaders must always remember that Cub Scouting was designed for parents to use with their sons. Parents do not simply let their sons join Cub Scouting. When they sign their son's application, they agree to participate too.

Make sure that all of your pack functions are "family friendly." Place some of your most outgoing and congenial adults near the door to greet everyone and make families feel welcome. Nametags are a big help. Thank families for coming - and for helping with whatever small task they may assist in. If some parents feel awkward about joining in, ask them to serve refreshments or pass out newsletters until they feel a part of the group.

### SOME IDEAS TO INVOLVE FAMILIES

- Parent/guardian meetings for the pack. Consider one before the annual planning meeting to secure input on what activities they would be interested in attending and supporting.
- Parent meetings on recruiting night. It isn't fair for leaders to expect cooperation and participation unless they have made it clear just what is expected. Families should know about their responsibilities before, not after, you have accepted the boy's application to join.
- Den leader/family meetings. Den leaders should hold meetings with their Cub Scout families to get to know them and to let them know what is expected within the den.
- Family induction ceremonies for new families emphasize that they, too, are part of the pack.
- Special pack meeting awards for dens with the most family participation.
- Advancement ceremonies should involve parents
- Partially completed projects can be sent home from den meetings to be finished with parental help for display or demonstration at the pack meeting. • Pack/den newsletters insure effective communication
- Cub Scout family outings. It's an old cliché, but the group that plays together, stays together.

### PARENT SURVEYS

One of the all-time favorites is the Parent Talent Survey Sheet found in the Cub Scout *Leader Book*.

## PICK A CARD TRICK

Prepare for this trick by dividing a deck of playing cards into two piles—one of red cards, one of black. Place them facedown on a table. Ask someone to pick any card from either pile and show it to someone else but not to you. Pick up the rest of the pile the person chose from and put it in your pocket. Ask the person to put his card anywhere in the remaining pile. Now pick up the pile and fan them out without letting the audience see them. Find the card that is a different color from all the others and show it, asking, “is this the one you chose? It will be, of course.

# The Möbius Strip

This is a great activity to have for those den meetings when you need a fast filler.

See if the boys can guess what will happen when they cut it.

1. Start with a long rectangle (ABCD) made of paper.
2. Give the rectangle a half twist.
3. Join the ends so that A is matched with D and B is matched with C.

This curious surface is called a **Möbius Strip** or Möbius Band, named after August Ferdinand Möbius, a nineteenth century German mathematician and astronomer, who was a pioneer in the field of topology. Möbius, along with his better known contemporaries, Riemann, Lobachevsky and Bolyai, created a non-Euclidean revolution in geometry.

Möbius strips have found a number of surprising applications that exploit a remarkable property they possess: one-sidedness. Joining A to C and B to D (no half twist) would produce a simple belt-shaped loop with two sides and two edges -- impossible to travel from one side to the other without crossing an edge. But, as a result of the half twist, **the Möbius Strip has only one side and one edge!**

To demonstrate this,

(1) start midway between the "edges" of a Möbius Strip and draw a line down its center; continue the line until you return to your starting point. Did you ever cross an edge?

(2) Next, hold the edge of a Möbius Strip against the tip of a felt-tipped highlighter pen. Color the edge of the Möbius Strip by holding the highlighter still and just rotating the Möbius Strip around. Were you able to color the entire edge?

(3) Now, with scissors cut the Möbius Strip along the center line that you drew. Then draw a center line around the resulting band, and cut along it. Did you predict what would happen?

Giant Möbius Strips have been used as conveyor belts (to make them last longer, since "each side" gets the same amount of wear) and as continuous-loop recording tapes (to double the playing time). In the 1960's Sandia Laboratories used Möbius Strips in the design of versatile electronic resistors. Free-style skiers have christened one of their acrobatic stunts the Möbius Flip.

The famous artist, M.C. Escher, used mathematical themes in some of his work, including a Möbius parade of ants. His flight of swans looks like it might be a Möbius Strip, but it's not. Can you see why not?

Martin Gardner wrote an amusing short story based on the Möbius Strip called "The No-sided Professor," which you can find in *Fantasia Mathematica*, a book edited by Clifton Fadiman.



## MAGIC RUBBER BAND

Loop one rubber band over the first two fingers of your right hand. Place a second rubber band over the tips of all four fingers, twisting it between each finger. Now grasp the loop of the first rubber band with your left hand bend the fingers of the right hand, and pull it over all four fingertips. When you straighten the fingers quickly, the first rubber band will jump mysteriously to the third and fourth fingers as shown. Make it jump back by repeating the process.

# PRISONER'S ESCAPE

Tie a piece of string around wrists of your "victim" (one of the boys in your den). Loop another piece of string over your victim's wrist and tie it to your wrists. You are now locked together. Challenge victim to get away without breaking the string or untying a knot. When he gives up, show him how. Push the center of your string through the loop on the inside of your victims wrist, bring this new loop back over his hand and draw it back through the wrist loop. You will be free. For double fun, tie two victims together in the same way.

# THE APPEARING KNOT

Here you hand a spectator an ordinary handkerchief behind his back. You snap your fingers. When he removes the handkerchief, a knot has mysteriously formed in the center.

METHOD: Begin by placing a handkerchief over the hand.

Note that end B hangs down lower than end A. Note too that end B is clipped between the third and fourth fingers.

The right hand turns palm down. In the same motion end A is clipped between the first and second fingers.

Release the third and fourth finger's grip on end B.

With a sharp downward movement of your right hand, shake the handkerchief off your right wrist. The result is that a knot is tied in the center of the handkerchief.

With just a bit of practice the one-hand knot can be formed instantly. If you have trouble getting the handkerchief to slide off your hand, twist it rope fashion before placing it on your hand. If the knot is formed in view of the audience, it happens so quickly that it will appear as if you shook the handkerchief and a knot mysteriously formed in the center.

# Hanky Stand-up

Make a handkerchief move up and down at your command as if it is standing up.

Supplies You Need:

Handkerchief with a hem

Full length drinking straw

## Setup

Carefully flatten a drinking straw. Next sew the straw into the hem of a handkerchief. Make sure the straw can't move within the hem. If your handkerchief does not have a seam, sew one in two of the sides.

## How to Perform

When you are ready to perform the trick, take the corner marked with an "A" and tie a knot in that corner. Hold the handkerchief with your right hand from the corner with the knot and let it hang down.

Tell your audience you are going to make the handkerchief stand up. With your left hand take the middle of the handkerchief where corner "B" is, and let go of the handkerchief with your right hand.

By slowly squeezing the straw with your thumb (this is the part you will need to practice), you can cause the handkerchief to slowly rise as if it is standing up. As you do this tell the audience that the handkerchief responds to your command. Say "Handkerchief--Stand!" or other similar commands.

# Magic Toothpick Trick

## Effect:

The magician shows a pan full of water with five toothpicks in the shape of a pentagon.

The magician takes his magic toothpick and dips it in the center of the pentagon. The five toothpicks fly apart, breaking the pentagon! Someone from the audience says... oh, that's just what happens when you do that, it's not magic. The magician arranges the five toothpicks back into a pentagon and hands the person in the audience the magic toothpick. The person dips it in the center. Nothing happens. It really was magic!

## Supplies:

- a tinfoil pan (a pie plate or leftover Chinese food plate work well)
- water
- 6 flat wooden toothpicks
- the magic ingredient: liquid dishwashing soap

## Before the Audience - Preparation:

Dip one of your toothpicks in liquid dishwashing soap. Set it aside for now.

Make sure your pan is clean. Rinse it well with water. Fill it quite full of water (but not so full that you're going to spill it).

## In Front of the Audience - Preparation:

Arrange the five SOAPLESS toothpicks in the shape of a pentagon. Make sure the tips of the toothpicks overlap so your pentagon stays together. This can be a bit of a challenge the first time you do it, so practice arranging the toothpicks at home a few times first and consider arranging them while the audience is seating itself.

Now, when the audience is settled, let them look at the pentagon. They may have to stand to do this or you may want to do the trick on the floor with the audience around you in a U-shape.

Tell the audience that you've arranged the toothpicks into a special five sided shape called a pentagon and that you're going to cast a spell on the sixth toothpick to imbue it with some of your magical force so it will be able to break apart the pentagon. (big words always impress an audience \*grin\*)

Take out the sixth toothpick (the one that was dipped in dish soap) and wave your hand over it while chanting some magical words. Close your eyes and frown a bit so it looks like you're working on putting your magic into the toothpick.

Words you could chant: Alaka penta Abraka magic

Now, dip the magical toothpick into the center of the pentagon (Make sure you dip the soapy end in the water and try to get it as close to the center of the shape as possible -- the soap shouldn't be visible anymore). The five toothpicks will fly apart.

If you have a non-believer in the audience, offer to let them try the trick. Arrange the pentagon in the water again and hand them the magic toothpick. Let them dip it in the center. It won't work!

If the audience asks you to do the trick a second time, just tell them that it takes awhile to recharge your magical force. You have to rest before you can put more of it into a toothpick, otherwise you could lose your magic forever!

## Secret:

Throughout history, a lot of 'magic' has really been science disguised with a few silly words. This is one of those tricks.

All things (including water) is made up of tiny things called molecules). Water molecules like each other and stick together (that's why when a bit of water falls on a table or window, it blobs together in a little droplet).

The surface of the water has a layer of clingy molecules on it -- this layer is called the water's **surface tension**. The toothpicks were nice and flat so they were floating on this layer.

# Coin Trick

## Effect:

The magician shows a glass, upside down, and a coin on a sheet of colored paper.

He puts a handkerchief over the glass and moves it over.

He pulls the handkerchief off and Abracadabra! the coin has disappeared.

## Supplies:

A sheet of construction paper (1), a clear glass, a handkerchief and a coin.

## Preparation:

Trace the glass onto the sheet of paper and cut the circle out. Then tape it to the glass so when you put it onto a piece of paper the same color it blends in.

## Secret:

When you do the above put the glass onto a piece of paper and just basically move the paper covered glass over the coin while the whole thing is under the handkerchief so the glass covers the coin. Pull off the handkerchief. The coin will have "disappeared".

# Chemical Magic for Ceremonies

---

## Magic in Pack Ceremonies

### 1. Magic Sugar Cube

Materials: clear glass of water, sugar cube, pencil

Set up: clearly and darkly mark the letter "W" (for wolf or webelos ceremony) or "B" (for bobcat or bear ceremony) on one side of the sugar cube. Be sure that the letter is very dark.

Effect: Letter appears to transfer from a sugar cube dropped in water to the back of the hand of the participants.

Scenario: Tell participants that the letter will magically leave the sugar cube and be printed on the hand of the scouts who are worthy to advance in rank. Drop sugar cube in water and have one scout place his hand over the top of the glass; other scouts place their hands on top of the first. Tell the scouts to concentrate on their new rank. After a 15 seconds or so, have the scouts take their hands away and look at the top of the hand that was over the glass. The letter appears on the hand.

How it's done: Before placing the sugar cube in the water, make some excuse to dip your thumb and fingers in the glass ("Boy, this sugar cube sure is sticky ..."). Wet your thumb and press hard over the letter to ink the bottom of the thumb. Then, assist each boy in placing his hand over the glass, pressing your thumb to the back of his hand while doing so. You will then have "stamped" the letter onto the back of the hand.

As long as it is done quickly and the boys are focused on the sugar cube, they will not notice the effect of the thumb on their hand.



## 2. Removing color from liquids.

Materials: food coloring, pitcher of water, 2 glasses, liquid bleach

Setup: place one drop of food coloring in bottom of one glass, 1 teaspoon of bleach in the other. Place glasses so that the audience cannot see the advance preparations.

Effect: Water poured into a glass changes color

Scenario: Water is poured into an "empty" glass and immediately changes color. The colored water is then poured into another "empty" glass which then turns back into "water."

How it's done: Water poured into first glass changes color on contact with the food coloring. Color is bleached out of water in the second glass. Be sure to hide the base of the glass with your fingers so that the coloring and bleach in the glasses cannot be seen.

### 3. Color-changing liquids (yellow-green-blue)

Materials: yellow and green food coloring, pitcher of water, 4 clear plastic glasses, liquid bleach

Setup: Four clear glasses: one empty, one with a drop of yellow food coloring, one with a drop of green food coloring, one with 1/4 teaspoon of liquid bleach. As in above, be sure audience cannot see the preparation or the bottom of the glasses during the trick.

Effect: Water changes colors from clear to yellow to green to blue as the liquid is poured into successive glasses.

Scenario: Water from a spring at a nearby Boy Scout camp has the special properties of changing into Cub Scout colors if boys have completed all of their requirements for their badge of rank. Water is poured from a special receptacle into the first glass. Water turns yellow when poured from first glass into second; water turns green when poured from second glass into third ("Are you boys sure that you completed all of the requirements for the \_\_\_\_\_ badge?"). Water turns blue when poured into last glass, indicating the boys have in fact completed the final test for their badge of rank.

How it's done: First glass is empty so water is clear when poured into the first glass. Water turns yellow when added to the glass with the drop of yellow food coloring; yellow water turns green when added to the glass with a drop of green food coloring; green water turns blue when added to the glass with the liquid bleach (the yellow color is bleached out of the green water, leaving the water blue in color.)

#### 4. Multi-colored liquids.

This trick requires the use of chemicals normally available at scientific supply stores; in fact, most chemistry sets will contain the required chemicals.

Materials: 6 clear plastic glasses, sodium carbonate, yellow and blue food coloring, white vinegar, phenolphthalein solution, liquid bleach

Setup: prepare the glasses as follows:

glass 1: pinch of sodium carbonate dissolved in 6 ounces of water

glass 2: 1 drop yellow food coloring

glass 3: liquid phenolphthalein (made from powdered phenolphthalein and rubbing alcohol); keep covered as solution evaporates.

glass 4: 1 drop blue food color

glass 5: 1/4 full white vinegar (be sure to palm the bottom half of the

glass until you begin pouring.

glass 6: 1/4 full liquid bleach

Effect: "Water" is poured into different glasses, each time changing to a different color. Color sequence is clear, yellow, red, purple, green, clear.

Scenario: Similar to the above except more glasses with more colors.

How it's done: Same as above. Reactions between chemicals in solution produce the different colors. Be careful to dispose of the last glass quickly as it does look like water but is really heavily laced with chlorine bleach (the last thing you want to happen is for a scout to come up and taste the "water")

## 5. Magic balloon.

Materials: large balloon (at least 8 inches in diameter when inflated), dry ice

Setup: small piece of dry ice inserted into balloon.

Effect: balloon continues to inflate, even after being tied closed.

Scenario: Balloon is partially inflated at the beginning of the meeting and tied. By the end of the meeting, the balloon has become even more inflated.

How it's done: the dry ice inside the balloon slowly vaporizes when added to warm air. Partially blowing up the balloon provides enough warm air for the process to occur.

## 6. Magic water test.

Setup: Styrofoam or paper cup (not plastic!) with slush powder ("Aqua-gel", "Joke-gel") in bottom of cup. Approx. 1 teaspoon of powder per 4 ounces of water. Slush powder is available at magic supply stores and novelty shops (usually in the gag gift section with the pepper gum, plastic vomit, etc.)

Effect: water is poured into a cup and then inverted over the boys' heads without spilling.

Scenario: Final test for boys advancing in rank. Pour water (I use water colored with blue food coloring) into the glass and tell the boys that if they are ready to advance in rank, then the spirit of scouting will protect them in this final test. Turn the cup upside down over the boys' heads.

Variations: Have parents hold small cups with gelled water over each boy and have the boys stick a straight pin through the bottom of the cup. Be sure that the cups are held above the sight of the parents as well so that they cannot see the gelled liquid inside.

How it's done: The slush powder causes the water to gel on contact and will not pour/leak from the glass.

## GATHERING TIME ACTIVITY

M	D	Y	G	N	E	C	K	E	R	C	H	I	E	F
E	E	T	I	G	E	R	O	L	E	B	E	W	G	L
L	N	E	Y	B	O	B	C	A	T	Y	M	O	D	A
B	N	F	T	C	A	M	P	I	N	G	O	L	E	S
M	E	A	W	I	U	D	C	A	P	T	H	F	L	H
E	R	S	A	O	N	B	G	L	N	K	C	A	P	L
C	G	O	L	D	R	G	S	E	U	L	B	H	B	I
N	U	N	I	F	O	R	M	O	T	T	O	E	E	G
A	S	A	L	U	T	E	A	R	N	S	A	L	S	H
I	T	E	Z	L	V	D	R	W	Z	R	O	P	I	T
G	F	M	B	E	L	T	G	G	A	B	O	F	M	O
E	A	E	I	L	G	W	O	M	E	R	F	U	O	O
L	R	H	I	S	T	O	R	Y	T	Y	D	L	R	L
L	C	T	N	E	R	A	P	S	K	I	T	S	P	S
A	K	E	L	A	N	O	I	T	C	E	L	L	O	C

### ACHIEVEMENT

AKELA  
ALLEGIANCE  
ARROW  
AWARDS  
BADGE  
BEAR  
BELT  
BLUE  
BOBCAT  
CAMPING  
CAP  
COLLECTION  
CRAFTS  
CUB  
DENNER  
EARNS  
EMBLEM  
FLASHLIGHT  
GOLD  
HELPFUL  
HISTORY

### HOME

LAW  
MEETING  
MOTTO  
MOWGLI  
NECKERCHIEF  
OBEY  
PACK  
PARENT  
PLEDGE  
PROGRAMS  
PROMISE  
SAFETY  
SALUTE  
SKITS  
SPORTS  
THEME  
TIGER  
TOOLS  
UNIFORM  
WEBELO  
WOLF

# SKITS

## The Magic Bandana

Two guys come out, one is the magician, one his not so smart assistant. The magician introduces his act and sends his assistant to a table behind him. The magician facing the audience tells Herkimer to do exactly as he says. There is a table by Herkimer which has a bandanna and a banana. The magician asks Herkimer to pick up the bandanna and to perform various actions such as put the bandanna in his right hand, fold it in half, fold the four corners together, stuff it in his left fist and upon one, two, three, it will disappear. However, Herkimer, picks up the banana, not the bandanna and performs these actions. At the end when Herkimer is supposed to show his fist, for the disappearance of the bandanna, he throws the mashed up banana at the magician instead. The magician chases him offstage.

## The Magic Doctor's Chair

*Characters:* 1 doctor and four patients.

*Props:* two chairs.

*Scene begins with doctor sitting on one of the chairs. First patient enters twitching his left arm.*

**Doctor:** And what's wrong with you, sir?

**Patient 1:** As you can see doctor I have this terrible twitch.

**Doctor:** Just sit on my magic chair and you'll get better.

*The patient sits on the chair and stops twitching, but the doctor's left arm starts twitching.*

**Patient 1:** Oh thank you doctor. You cured me!

*The patient leaves, the doctor still twitching calls for the next patient.*

**Doctor:** Next.....And what's wrong with you sir?

*This patient has the hiccups. The process of sitting in the chair is repeated. The doctor now has a twitch and the hiccups.*

*The third patient is called in, both his legs keep flicking in the air. The process is again repeated so that the doctor now has a twitching arm the hiccups and both legs flicking in the air.*

*The doctor now calls patient four. This patient looks quite normal, enters and sits in the magic chair.*

**Doctor:** And what may I ask is wrong with you sir?

**Patient 4:** I've got a terrible case of the trots doctor.

*The doctor runs off the stage holding his stomach.*

### Run-On

**Cub #1:** I understand you like to do magic tricks. What's your favorite?

**Cub #2:** Sawing people in half.

**Cub #1:** Interesting, and are there any other people in your family?

**Cub #2:** Yes, I have two half brothers and two half sisters.



## ACTIVITIES – MAGIC TRICKS



### Magic Knot-Tying

The den leader provides several pieces of rope or cord about three feet long. The den chief or helper asks a Cub Scout if he can tie an overhand knot in the middle of the cord without letting go of either end. He lets the Cub Scout try it, then he shows him the trick: First he folds his arms over his chest, then he leans over and picks up each end of the cord without unfolding his arms. As he straightens up, he unfolds his arms - still holding the ends of the cord - and, presto, there's the overhand knot!

### The Mysterious Coin Balance

*Here's a great trick to demonstrate your mastery of mind over matter! You can balance a coin at your fingertips, but no one else can!*

*Props:* One large coin, one straight pin

Have a regular straight pin concealed in one hand, between the first two fingers. With the other hand, pull a coin out of your pocket and allow it to be examined by the audience, or borrow a coin from one of them!

When you get the coin back, lay it down on top of the straight pin in your other hand. Now, raise the coin to a standing position near the ends of your fingers, and as you do raise the straight pin with it, making sure no one but you knows the pin is there.

Keep pressure on the pin held between your two fingers, and the coin will balance there as if held by unseen forces! You can talk about mind over matter, or wiggle the fingers of your other hand over the coin as if that was where your power emanated from!

After a few moments, slowly release pressure on the pin, and it should let the coin gently drift back down onto your fingers! Don't forget to get rid of the pin while people are examining the coin again!

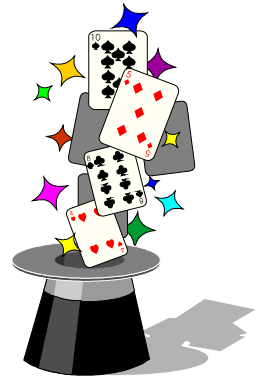

### The ABRACADABRA Card Trick

*Here is a great card trick that has the advantage of being self- working!*

*Props: 21 random cards from any deck.*

*To perform the trick:*

Take 21 cards and deal them out into three columns by dealing seven rows of three. Deal three cards across for the first row, then another card on top of each for the next row, and so on until you have seven rows of cards in three columns for a total of 21 cards. Make sure you deal out each of the rows so you can still see the cards behind it.

Now have someone think of any card in one of the columns, and then tell you which column the card is in. Pick up one of the other columns, then the column he chose, and then the last column, so that the column with the chosen card is between the other two.

Deal them out again the same as before, and have your volunteer tell you which column the card is now in. Again, pick up the cards so that the column he pointed to is between the other two.

Repeat the process of dealing out the cards, having him tell you which column his card is now in, and picking up the cards so that the column with his card is between the other two columns. You have now done this three times, and it's time to find his card!

Hold the cards face down in your hand, as if you were going to deal them out again, but instead ask your volunteer if he has ever heard the magic word ABRACADABRA. Say that not many people know it, but ABRACADABRA is a magic word for finding things, and that you'll show him what you mean. Spell the word ABRACADABRA, and for each letter deal one of the cards face down on the table. When you reach the last "A", pause, and then turn over that card. It will be the chosen card! As long as you spell ABRACADABRA right, this trick will work every time!

### Find the Mystery Card

*Props:* Deck of cards

*The Trick:* Your friend will select a card from a deck and without seeing what she has chosen, you will easily find the card after she puts the deck back together!

*How It Works:*

1. Have one of your friends select one card from a deck.
2. Have him look at the card and show the others in the room (excluding you) what the card is.
3. While everyone but you is looking at the your friend's card, look at the bottom card of the deck.  
*NOTE:* The card that is on the bottom of the deck will be your key card (for example, it may be the Queen of hearts), and you will use it to find the card your friend chose.
4. After everyone has seen the card, have him place the card on the top of the deck and put the deck back together.
5. Cut the deck, and place the bottom part on the top part.
6. The Queen of hearts (your key card!) will be on top of your friend's card.
7. Turn the deck over, and spread it out. Find the Queen of hearts (the key card)
8. The card exactly to the right of that will be the mystery card!

### Postcard Power!

*Props:* Five postcards, pencils, and envelopes.

*The Trick:* Have five of your friends write their names on separate postcards. Give them each an envelope. Have your friends put their postcards in an envelope. One person should collect all the envelopes, mix them up, and hand them to you. Using your powers, you will hand each of your friends an envelope, which to their surprise will be the one with their name on the postcard inside!

*How It Works:*

1. You need five postcards, five pencils, and five envelopes. All the same shape, size, and color.
2. While no one is around, make a small mark on each of the envelopes so you will be able to identify the owner of the card.
3. With the first envelope, you make a small mark on the back, in the bottom right. That is number one. When you give someone that envelope, in your mind, associate them with number one.
4. Do the same with the next envelope, except make the small mark in the bottom left side. Remember who is number two when you give this out.
5. With number 3, make the mark in the middle of the envelope.
6. With the 4th, make the mark in the top left side.
7. With the fifth, you put the mark on the top right.

\*\*\*The most important part of this trick is to make sure you remember who is what number!\*\*\*

The rest is easy, just use your powers and hand them back their envelopes.

## The Floating Pushpin

You really have to try this trick to see how cool it is. It really *looks* magical.

*What they see:* Dropping a pushpin into a full glass, you tell your audience about an old Indian water purification ritual they used to do when they found new lakes or rivers. The pin sinks to the bottom. But as you chant, the pin slowly stands up on its point, spins, and then rises to the top of the water!

*Props:* A glass that's nearly full of clear soda pop, A pushpin

*What you do:*

1. While telling your audience about an old water purification ritual you learned, drop the pushpin in the soda. The story you are telling them is called the "patter". This trick is based entirely on the patter.
2. Tell them that in ancient times, the Indians didn't have filters and things like we know them. When they came to rivers or lakes that they didn't know, they would first bless the water so that all of the dangerous things would rise out.
3. Begin to chant like an Indian. Just sound mystical and mysterious as you moan. While you do this, watch the pin closely.
4. *By itself*, the pin will start to stand up. You may think it's because you're a good Indian dancer, but really it's because the pin is so light the tiny bubbles in the soda make it float as they stick to the plastic.
5. But since your audience doesn't know this, pretend you're doing it. Gesture with your hands as if you are drawing it out magically. The pin will float all the way to the surface, where you can pull it out!

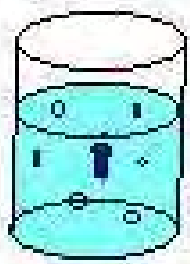

*Special Tip:* The flatter the soda is, the longer it will take the pin to rise. But if you just poured the soda, it may float so fast that you can't do your little dance. Practice until you find a good amount of time to let the soda sit.



# CRAFTS

## Magic Wand Craft

*Materials needed:* Newspaper; Tape; Mixture of 1/2 white glue and 1/2 water OR paper mache paste

(1 part flour to 5 parts water... let boil 3 minutes and then cool); magical item -- examples include sparkles/glitter, pipe cleaner, feather, ribbon, piece of twisted tinfoil; silver, gold, black, brown or grey paint or markers.

### *Instructions:*

The key to a good magic wand is a special magical center. The most important part of this craft, therefore, is choosing your magical center (you aren't going to be able to see it, but you'll know it's there)! You can use a pipe cleaner or twisted tinfoil (*"hair from a unicorn tail"*), feather (*"Phoenix feather"*), or ribbon (*"dragon heartstring"*). You can use things you find outside (feathers) or something special of yours. You can also sprinkle on a few sparkles for that extra bit of punch.

Put your magical items on the edge of a 1/2 piece of newspaper and roll it up tight like a sausage. You might want to chant a couple of magical words as you roll (ROLLUS ENCOMPUS, for example).

Take a look at the length of your wand. If you like it, great! If it's too long, take scissors and trim it down (every wand is different!)

Tape the newspaper sausage tightly so it doesn't unroll as you work. Put tape over the two ends so your magical items don't fall out.

Take 1 inch x 6 inch (ish) strips of newspaper and dip them in the paper mache paste OR water/glue mixture. Wrap them tightly around the newspaper sausage.

Let your wand dry.

Paint the wand your chosen color (or color with markers). You can also dip the tip in white glue and then coat with silver or gold sparkles.

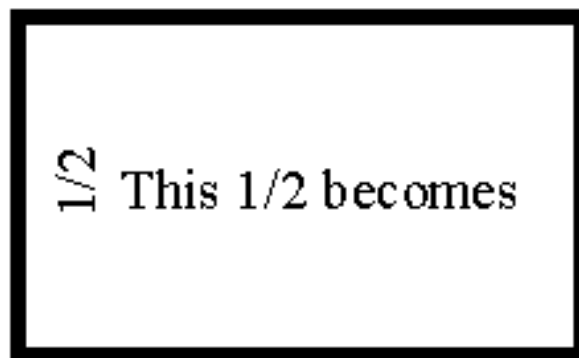
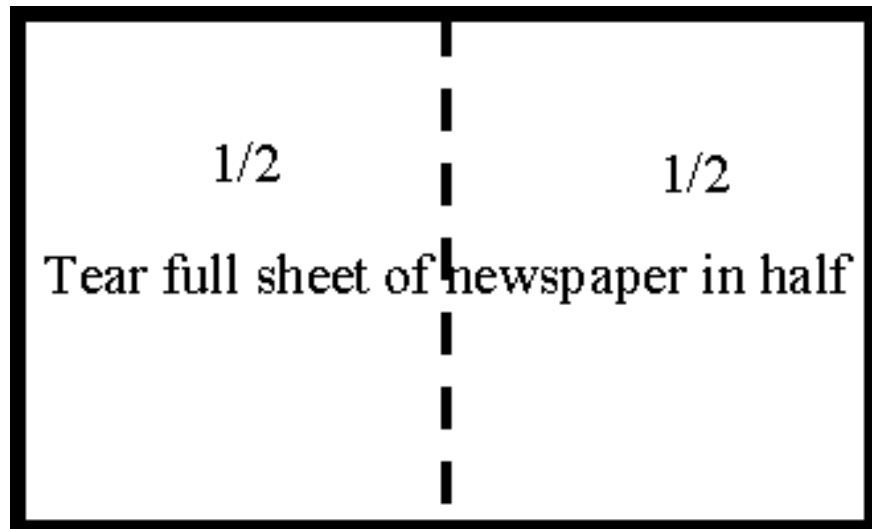

### Magic Gel

*This is a substance that is both liquid and solid at the same time.*

#### *Directions:*

Measure five parts cornstarch and four parts water. Mix this together with your hands. After the cornstarch is totally dissolved in the water, explore all the unusual and magical things that can be done with this mixture:

- If a fist is pounded on the mixture, it's hard. But if a relaxed hand is placed on top of the mixture, the hand will sink like it's in quicksand!
- A chunk of magic gel can be broken off just like with other hard materials. But if some of the mixture is placed in your hand, it begins to drip off – just like liquid.
- It can be poured like liquid, and as it is pouring, you can crack off the drips – like a solid.

# GAMES

## The Mystifying Reader

*Equipment: Pencil and paper for each Cub*

*Formation: Circle*

Give all the Cubs a slip of paper - each the same size and shape as the others. Then ask everyone to write a short sentence of four or five words. The words should be written plainly and should not be shown to any other person. Then instruct them to fold their papers and bring them to someone previously selected to act as the 'guardian'. No one, not even the guardian, should attempt to read the papers, still folded. As you gravely close your eyes, place the folded paper against your forehead and remain a moment in deep thought. Then call out any sentence that has occurred to you and as who wrote it. One of the Cubs, who is an accomplice, and who did not write a sentence, admits authorship of the sentence. Then unfold the paper, apparently to verify his announcement (and read the sentence to yourself). Then place the paper in your left hand and ask the guardian for another. Repeat the same preliminaries and then call out the words written on the previous paper, which you have had the opportunity to read. This will be a bona fide answer and one of the Cubs will have to admit to writing the sentence. Keep the performance up in this manner until all the player's slips of paper have been read. In order for the trick to be successful, the accomplice must be careful to conceal from the audience the fact that he has not included a sentence in the collection given to the guardian.

# Resources and Credits

## Magic Web Sites:

<http://www.magickingdom.co.uk/magic.htm#>

[http://www.kidsdomain.com/kids/links/Magic\\_Tricks.html](http://www.kidsdomain.com/kids/links/Magic_Tricks.html)

<http://www.covenanthealth.com/parentingfair/magic.html>

<http://www.kidzone.ws/magic/>

<http://wtsmith.com/rt/magic.html>

<http://www.caveofmagic.com>

## **Elective 13: Magic (p 208) Bear Book**



# ScoutSongs.com Virtual Songbook



## SEARCH

## CATEGORIES

[All Songs](#)  
[Tanah Keeta](#)  
[Action Songs](#)  
[Boy Scout Songs](#)  
[Girl Scout Songs](#)  
[Patriotic Songs](#)  
[Rounds](#)

## LINKS

[BSA Site](#)  
[GSUSA Site](#)  
[Scouting Links](#)

## ABOUT

[Home](#)  
[Acknowledgements](#)  
[Privacy Statement](#)  
[Scoutsongs FAQ](#)  
[TK Patches](#)  
 (195K)

## Index of All Songs In Alphabetical Order

[1492](#)

[Akela's Trail](#)

[Alice the Camel](#)

[America](#)

[America the Beautiful](#)

[Announcements](#)

[Ants Marching Song](#)

[A Scout Is: The Boy Scout's Anthem](#)

[The Ash Grove](#)

[Banana Dance](#)

[The Bear](#)

[Big Fat Hen](#)

[Bingo](#)

[Boom Chica Boom](#)

[Boy Scout Camp](#)

[Boy Scouts of America](#)

[Bug Juice](#)

[Cabin in the Woods](#)

[Clementine](#)

[The Cub Scouts Went Over the Mountain](#)

[Cub Scouts Whistle While they Work](#)

[Daisy](#)

[Dem Bones](#)

[Dog Cat Song](#)

[Do Your Ears Hang Low](#)

[Do Wally](#)

[Down By the Riverside](#)

[Father Abraham](#)

[Flea](#)

[Follow Me Boys](#)

[Girl Scout Camp](#)

[Girl Scouts Together](#)

[Girl Scout World](#)

[God Bless America](#)

[God Bless The U.S.A.](#)

[God Bless My Underwear](#)

[Grand Old Duke of York](#)

[Grand Old Captain Kirk](#)

[Grannies in the Cellar](#)

[Green Grass Grew All Around, the](#)

[Ham and Eggs](#)

[Happy Wanderer, the](#)

[Head, Shoulders, Knees, and Toes](#)

[Here We Sit Like Birds in the Wilderness](#)

[Johnny Verbeck](#)

[Kum Ba Yah](#)

[Little Black Things](#)

[Littlest Worm](#)

[Make New Friends](#)

[Meadow Muffin Blues](#)

[Mountain Dew](#)

[Muffin Man, the](#)

[Mules](#)

[Music Counter](#)

[My Bonnie](#)

[My Leader](#)

[My Name is Joe](#)

[Oh! How I Hate to Get Up](#)

[Oh I Wish I Were](#)

[Oh! What A Beautiful Morning](#)

[Old MacDonald Had A Farm](#)

[Old Mr. Ford](#)

[One Finger, One Thumb](#)

[One Tin Soldier](#)

[On My Honor](#) (Boy Scout Version)

[On My Honor](#) (Girl Scout Version)

[On My Honor](#) (Girl Scout Cookie Version)

[On Top of Spaghetti](#)

[Paddle Song](#)

[Paw Paw Patch](#)

[Philmont Hymn](#)

[Pink Pajamas](#)

[Pizza](#)

[Prune Song](#)

[Purple Stew](#)

[Quartermaster's Song, the](#)

[Ravioli](#)

[Rheumatism](#)

[Row, Row, Row Your Boat](#)

[Scout Camp](#)

[Scouting Spirit](#)

[Scout Vesper](#)

[She Wears a "G"](#)

[Singing in the Rain](#)

[SixPence](#)

[Star-Spangled Banner, the](#)

[Steamboat Bill](#)

[Swing Low, Sweet Chariot](#)

**shop now**  
 AND SAVE!  
 amazon.com.



[God Bless America](#)

Irving Berlin  
New \$11.19!

[The Star-Spangled Banner](#)

Francis Scott Key

[The National and Religious Song Read...](#)

William E. Studwel...

[World War I Songs](#)

Frederick G. Vogel...

[When This Bloody War Is Over](#)

Max Arthur

[A Patriot's Handbook](#)

Caroline Kennedy

[The Flag, the Poet and the Song](#)

Irvin Molotsky

(Prices May Change)  
[Privacy Information](#)

[Hi Ho! Nobody Home](#)

[Hokey Pokey](#)

[I Am Thankful To Be An American](#)

[I'm a Daisy Girl Scout](#)

[I'm a Girl Scout](#)

[I Had a Little Chicken](#)

[If You're Happy](#)

[I Like Bananas](#)

[I Love You So](#)

[I Met a Bear](#)

[I'm Happy Whan I'm Hiking](#)

[In the Loop of the Octoraro Bend](#)

[I Points to Myself](#)

[It's a Good Time to Get Acquainted](#)

[It's a Lie](#)

[John Jacob Jingleheimer Schmidt](#)

[Johnny Had A Head](#)

[Take Me To the Scout Camp](#)

[Tanah Keeta Hymn, the](#)

[Taps](#)

[This Land is Your Land](#)

[Three Jolly Fishermen](#)

[Three Rodents w/ Defective Vision](#)

[Thunderation](#)

[Titanic and Alternate Titanic](#)

[Tom the Toad](#)

[Trail the Eagle](#)

[Vive L'Amour](#)

[We're Here](#)

[We're Here Because We're Here](#)

[What Did Delaware, Boys?](#)

[When E're You Make a Promise](#)

[Yankee Doodle](#)

[You're a Grand Old Flag](#)

# Songs

One of the hardest things about doing the sessions on songs for POW WOW is submitting material for the "book".

We felt this year we would include our resources, places that we have found over the years, sites that everyone knows plus some sites that may not be as well known.

This is not an all inclusive list since we have not been to every site there is (although my wife would swear that I spend enough time on the computer that I must have been to each site by now!)

We will still list some of our favorites, but please visit the sites we have included, to access the thousands of songs that you can do at any of your meetings.

## **Ah, that brings up a thought! Why do songs anyway?**

I like what Clair Mansfield had to say on her web site.  
<http://www.angelfire.com/oh/claremansfield/cubscoutsongs.html>

Why are songs important in Scouting? Well, in addition to being fun, they teach the boys the life skills of working together, and following directions, and also improve a boy's memorization, while he learns the words. The songs you teach your Cubs now, are one aspect of the program that they are not likely to forget when they themselves are adults, and they will pass these songs onto their children, creating a heritage and bond between generations. And, you thought songs were just for pleasure!

So, warm up your vocal cords, and remember the wise words we in Scouts live by when it comes to singing - "If you can't sing well, sing LOUD!" (I, sing loud )

You will find that the boys really enjoy the silliness or grossness of the lyrics, and forget that they thought singing was uncool. In fact, introducing silly and gross songs, may earn you the reputation for being a "Cool" leader.



I hope we can all be "cool" leaders. Thank you for giving us the chance to share some of what we have with you.

Barb Cuff

Joe Trafficante

John Rex

Here is a song that would make a great end to a meeting, campfire, or other gathering.

## AMERICA, AMERICA

[\(Download MIDI file\)](#)

(Suggested as campfire closing, recessional. Leader sings verse once, remainder join in for second, third, etc. time as group follows the leader out of the campfire area. After three or four times through, just hum the tune.)

A-mer-i-ca, A-mer-i-ca,  
How **can** I **tell** you **how** I **feel**?  
**You** have **giv-en** **me** your **trea-sures**,  
**I love** you **so**.

---

Return to [The Pope's Place](#)



## Kum Ba Yah

**Kum ba yah, my Lord, kum ba yah!**  
**Kum ba yah, my Lord, kum ba yah!**  
**Kum ba yah, my Lord, kum ba yah!**  
**Oh Lord, kum ba yah!**  
**Someone's sleeping, Lord . . .**  
**Someone's crying, Lord . . .**  
**Someone's singing, Lord . . .**  
**Someone's laughing, Lord . . .**  
**Someone's praying, Lord . . .**  
**Someone's Scouting, Lord . . .**  
**Someone's camping, Lord . . .**  
**Kum ba yah, my Lord, . . .**

# THE NIGHT THEY MADE THE FIRST CUB SCOUT

[\(Download MIDI file "firstcs.mid"\)](#)

**Ma**-ny years a-go **on** this ver-y **night**  
Some **peo**-ple ga-thered 'round a **camp**-fire's **light**  
**Ev**-ry-one was **say**-ing the **world** was in a **mess**  
**Not** e-nough **peo**-ple try-ing to **do** their **best**. (So...)

Chorus:

...They **took** a lit-tle **Blue**  
and they **took** a lit-tle **Gold**  
They **took** a lit-tle **boy** about **eight** years **old**  
**Turned** him a-round and **lo** and be-hold  
**That's** how it **came** a-bout  
The **night** they made the **first** Cub Scout.

Now they **come** in ev-'ery **size**, they **come** in ev'ry **shape**  
And **ev**-ry-where they **are**, the **world's** a bet-ter **place**  
Ev-'ry **Bob**-cat and **Bear**, ev-'ry **Wolf** and We-be-los  
Re-mem-bers that **night** ma-ny years a-go. (When...)

(Repeat chorus)

**Ti**-ger Cubs are **new**, the **boys** aren't ve-ry **old**  
You **know** it won't be **long** be-fore they **wear** the blue and **gold**  
To **Search**, Dis-co-ver, **Share** with their **par**-ents in **tow**  
**Hea**-ded down the **path** that star-ted **years** a-go. (When...)

(Repeat Chorus)

**Lea**-ders are the **ones** who **make** the pro-gram **go**  
And **Trai**-ners are the **ones** to put the **lea**-ders in the **know**  
How the **Pro**-mise and the **Law** help the **Cub** Scout **Grow**  
And **Blos**-som on the **trail** that star-ted **years** a-go. (When...)

(Repeat Chorus)

Oh, yes, ...

(Repeat Chorus)

From [The Pope's Place](#)

## Songs for special occasions

### Grace

#### Blessings Of This Day

(Tune: "Gilligan's Island" Theme)

We thank Thee, Lord for giving us  
The blessings of this day;  
For friends and food and family,  
And showing us the way.  
The bounty that you set before  
Us, proves to us you care.  
We praise you, Lord, for showing us  
Your presence everywhere.  
So, join us at this table, Lord,  
As we prepare to dine.  
All that we have is sent from you;  
And all we have is thine.

(Lyrics copyrighted 1996 by Clare Mansfield, GWRC)



#### Alphabet Grace

(Tune: 1st 2 lines of "Alphabet Song")

A-B-C-D-E-F-G  
Thank you, God for feeding me.

#### God Is Great God Is Good

(Tune: "Michael Row The Boat")

God is great, God is good, Alleluia.  
Let us thank Him for our food, Alleluia.  
By His hand we all are fed, Alleluia.  
Thank you, Lord, for daily bread, Alleluia

# Repeat Songs

## Boom Chicka Boom

I said a-boom-chick-a-boom! [Group echoes.]  
I said a-boom-chick-a-boom! [Group echoes.]  
I said a-boom-chick-a-rock-a-chick-a-rock-a-chick-a-boom!  
[Group echoes.]

Uh-huh! [Group echoes.]  
On Yeah! [Group echoes.]  
This time! [Group echoes.]  
We sing! [Group echoes.]  
**HIGHER!**

Each time a leader adds a different variation such as: **LOWER, WHISPER, LOUDER, TONGUE-IN-CHEEK, SEXY, GROOVY (COOL).**



## Goin' On a Lion Hunt

Audience echos each line. You can also have audience sets up clap or slap legs to the rhythm

Goin' on a lion hunt.  
Goin to catch a big one.  
I'm not afraid.  
Look, what's up ahead?  
Mud!  
Can't go over it.  
Can't go under it.  
Can't go around it.  
Gotta go through it. [Make sloshing sounds and move hands as if slogging.]

Following verses:

Sticks. [Snap fingers.]  
Tree. [Make gestures climbing up and down.]  
Gate. [Make gate-opening gestures.]  
River. [make swimming gestures.]  
Cave. [Go in it and find lion. Reverse all motions quicky to get home.]

-- Thanks to Delmont Scout Reservation and Resica Falls Scout Reservation 1996  
Songbook

## Froggie

The leader or leaders begin this song by starting the tempo by slapping their thighs then clapping their hands. Then yell the following. Remember - this is an echo song.

This is a repeat after me song

This is a repeat after me song (audience echo)

(body)

Dog

Dog (audience echo)

Dog - Cat

Dog - Cat (audience echo)

Dog - Cat - Mouse

Dog - Cat - Mouse (audience echo)

Froggie

Froggie (audience echo)

Itty Bitty teeny weenie little greenie frogie

Itty Bitty teeny weenie little greenie frogie (audience echo)

Jump, jump, jump little froggie

Jump, jump, jump little froggie (audience echo)

Little greenie froggie eating all the bugs and spiders

Little greenie froggie eating all the bugs and spiders (audience echo)

Fleas and flies are scrumpditllyitious

Fleas and flies are scrumpditllyitious (audience echo)

Ribit ribit ribit ribit ribit ribit CROAK !

Ribit ribit ribit ribit ribit ribit CROAK ! (audience echo)

(pause)

**FASTER !** (speed up the tempo)

**FASTER !** (audience echo)

(repeat body)

(pause)

**CUB SCOUT SPEED !!** (*speed up the tempo*)

**CUB SCOUT SPEED !!** (*audience echo*)

(*repeat body*)

(*pause*)

**SUPER CUB SCOUT SPEED !!!!** (Heres the tricky one)

**SUPER CUB SCOUT SPEED !!!!** (*audience echo*)

Dog croak ! (*one slap "Dog", One clap "Croak"*)

(*After a few times the audience will get SUPER CUB SCOUT SPEED*)

-- Thanks to David M. Sanchez, Cubmaster, Pack 265, San Jose, Ca.



## I've Got That Scouting Spirit

I've got that Scouting spirit up in my head,  
up in my head, up in my head.

I've got that Scouting spirit up in my head,  
up in my head to stay.

2. I've got that Scouting spirit deep in my heart.

3. I've got that Scouting spirit down in my feet.

4. I've got that Scouting spirit all over me.



## The Cat Came Back

Old man Johnson had troubles of his own.  
Had a little cat that wouldn't leave him alone.  
He tried and tried to give him away,  
He gave him to a man going far, far away.

**CHORUS:**

But the cat came back, the very next day.  
But the cat came back, they thought he was a goner,  
But the cat came back, he just couldn't stay away, away, away.

He gave it to a man going up in a bal.  
Told him to give it to the man in the moon  
The bal. came down about 20 miles away  
And where that man is we just can't say.

(Chorus)

He gave him to a boy with a dollar note,  
Told him to take up the river in a boat,  
Tied a rock round its neck must have weighed a hundred pounds,  
And now they're dredging the river for the little boy who drowned.

(Chorus)

He gave him to a man going way, way out west,  
Told him to give it to the one he favored best,  
First the train jumped track, then it hit the rail,  
And no one is alive today to tell the gruesome tale.

(Chorus)

Old man Johnson said he'd shoot that cat on sight,  
So he loaded up his shotgun with nails and dynamite.  
He waited and waited for that cat to come around,  
But ninety seven pieces of the man were all they ever found

(Chorus)

The H-bomb fell just the other day,  
The A-bomb fell in the very same way,  
Russia went, China went, and the USA  
The human race was destroyed without a chance to pray.

## Fast Food

Tune: A ram sam Sam

Pizza Hut a Pizza Hut  
Kentucky Fried Chicken and a Pizza Hut  
Pizza Hut a Pizza Hut  
Kentucky Fried Chicken and a Pizza Hut  
McDonald McDonalds  
Kentucky Fried Chicken and a Pizza Hut

A Burger King a Burger King  
Long John Silvers and a Burger King  
A Burger King a Burger King  
Long John Silvers and a Burger King  
Red Lobster Red Lobster  
Long John Silvers and a Burger King

Dairy Queen A Dairy Queen  
Chucky Cheese and a Dairy Queen  
Dairy Queen A Dairy Queen  
Chucky Cheese and a Dairy Queen  
Roy Rogers Roy Rogers  
Chucky Cheese and a Dairy Queen

### *Actions*

Pizza Hut - Make shape of a hut in the air  
Kentucky Fried- Flap elbows up and down in the manner of a demented chicken  
McDonalds - Put hands on top of head and bridge out and down to produce the "Golden Arches"  
Burger King - Put hands on head with fingers up to make a crown  
Long John Silver - mimic sword play  
Red Lobster - hold up arms and bring fingers down on thumbs like lobster claws snapping  
Dairy Queen - mimic milking a cow  
Chucky Cheese - mimic throwing up a pizza  
Roy Rogers - mimic riding a horse



## If I Weren't a Boy Scout ...

[Tune: This is the Music Concert]

If I were not a Boy Scout, I wonder what I'd be

If I were not a Boy Scout, a .....

1. A bird watcher I'd be

Hark a lark, flying through the park, SPLAT!

2. A plumber I would be

Plunge it, flush it, look out below!

3. A mermaid I would be

Bloop, bloop, bloop, bloop, bloop, bloop!

4. A carpenter I'd be

Two by four, nail it to the floor!

5. A secretary I'd be

z-z-z-z get the point, z-z-z-z get the point?

6. A teacher I would be

Sit down, shut up, throw away your gum!

7. An airline attendant I'd be

Coffee, tea, or me, sir; here's your little bag, BLEH!

8. A typist I would be

Ticka, ticka, ticka, ticka, ticka, ticka, ZING!

9. A hippie I would be

Love and peace, my hair is full of grease!

[or] Hey Man! Cool Man! Far out! Wow!

10. A farmer I would be

Here's a cow, there's a cow, and here's another yuck!

[or] Come on Betsy give... the baby's gotta live

11. A laundry worker I would be

Starchy here, starchy there, starchy in your underwear!

12. A cashier I would be

Twenty nine, forty nine, here is your change, sir!

13. A gym teacher I'd be



**We must, we must, improve the bust!**

**14. A medic I would be  
Turn around, drop your pants, jab, jab, jab!**

**15. A doctor I would be  
Take a pill; pay my bill! I'm going golfing!  
[or] Needle! Thread! Stick 'em in the head!**

**16. An electrician I would be  
Positive, negative bzzzzt zap**

**17. A fireman I would be  
Jump lady, jump... whoa spat!**

**18. A cook I would be  
Mix it, bake it; heartburn-BURP!**

**19. A ice cream maker I'd be  
Tutti-frutti, tutti-frutti, nice ice cream!**

**20. A politician I would be  
Raise the taxes, lower the pay, vote for me on election day!**

**21. A butcher I would be  
Chop it up, grind it up, make a little patty!**

**22. A garbage collector I'd be  
Lift it, dump it, pick out the good stuff  
[or] Pile that garbage. Pile that garbage. Pile it to the sky.**

**23. A [Domino's] pizza maker I'd be  
30 minute, fast delivery!**

**24. A clam digger I would be  
Dig one here, dig one there-Oh my frozen derriere!**

**25. Superman I would be  
It's a bird, it's a plane, where is Lois Lane?**

**26. Lois Lane I would be  
Get away, get away, get away, Clark Kent!**

**27. A cyclist I would be  
peddle, peddle, peddle, peddle; ring, ring, ring!**

28. A truck driver I'd be  
Here's a curve, there's a curve. HERE'S A BETTER CURVE!  
[Makes outline of shapely woman.]
29. A house cleaner I'd be  
Ooh, a bug; squish it in the rug!
30. A baby I would be  
Mama, Dada, I wuv you!
31. A Preacher I would be  
Well, well, you never can tell; you might go to heaven, or you might go to ...
32. A DJ I would Be,  
Miles of smiles on the radio dial.
33. A Stewardess I would be,  
Here's your coffee, here's your tea. here's your paper bag, urrrp
34. A Baker I would be,  
Donuts! Eclairs! Buy My Buns!
35. A Lifeguard I would be,  
Save yourself, Man. I'm working on my tan!  
[or] Mouth to Mouth Resuscitate, What a way to get a date.
36. A Lawyer I would be,  
Honest. I swear, My client wasn't there
37. An Undertaker I would be,  
6 x 4, nail them to the floor.
38. An Engineer, I would be,  
Push the button, push the button, kick the darn machine.
39. A Ranger I would be,  
Get eaten by a bear, see if I care.
40. A Scoutmaster I would be,  
Do this, do that, I'm gonna take a nap.
- Finally: A Girl Scout I would be!

# Silly Holiday Songs

## A Scout's Christmas

By K. Meyers, D. Busker, and the boys of Den 4, Pack 1515, Alexandria, VA  
(tune: Jingle Bells)

Dashing through the den,  
With a rope held by each end,  
Tying a bowline knot  
Then showing what I've got.

Whittling with my knife  
On a practice Dial soap bar.  
I can hardly wait,  
Scout camp can't be far.

Bait a hook,  
Learn to cook,  
Bike ro-de-os.  
Neckerchief slides,  
Canned food drives,  
Learning to take photos.

Pancake mix,  
Carving sticks,  
Keeps us on the run.  
Our families  
Make all these  
Memories so much fun.

Dashing through the camp,  
Putting up the tents,  
Popping all the corn,  
Blowing that morning horn.

Of scout camp we all dream  
We'll soon be old enough  
Tigers, Bobcats, Wolves, and Bears  
We're made of real tough stuff!

Half-hitch knots,  
Setting up cots,



Playing fun new games.  
Hammers and nails,  
Compass and trails,  
Arrow points are the thing.

Santa's coming,  
We've been good,  
As good as we can be...  
Load our stocking  
With a pocket knife,  
Boy Scouts we want to be!

-- Thanks to Pete Farnham, CM, Pack 1515, GW District, NCAC, Alexandria, VA

## The Twelve Scouting Days of Christmas

(Tune: 12 Days of Christmas. Substitute Christmas for Scouting in the leading lines as you wish)

On the first day of Scouting, Akela gave to me.....

A Den Leader swinging from a tree!

On the second day of Scouting, Akela gave to me.....

Two Screaming Bobcats,

And a Den Leader swinging from a tree!

*OK, you should have the idea by now. Here's the rest of these silly verses:*

**Third Day**

Three Skinny Wolves

**Fourth Day**

Four Hungry Bears

**Fifth Day**

Five We be los

**Sixth Day**

Six Arrow points

**Seventh Day**

Seven Silly Den Chiefs

**Eighth Day**

Eight Shouting Scouts

**Ninth Day**



**Nine Warring Eagles**

**Tenth Day**

**Ten Derby Cars**

**Eleventh Day**

**Eleven Funny Den Skits**

**Twelfth Day**

**Twelve Wacky Cheers**

-- Thanks to Jack W. Weinmann

## **"I'm A Snowflake" by Karen Rogers**

**Tune: Clementine**

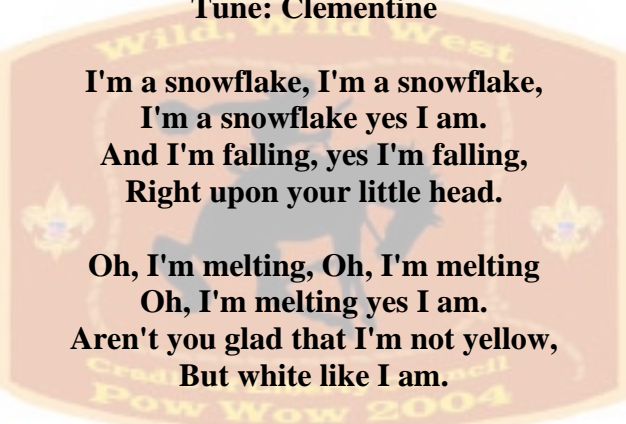

**I'm a snowflake, I'm a snowflake,  
I'm a snowflake yes I am.  
And I'm falling, yes I'm falling,  
Right upon your little head.**

**Oh, I'm melting, Oh, I'm melting  
Oh, I'm melting yes I am.  
Aren't you glad that I'm not yellow,  
But white like I am.**

--Thanks to Chuck Bramlet, ASM Troop 323, Thunderbird District, Grand Canyon Council, Phoenix, Az. and the Thunderbird District, TRC, Cub Scout Roundtable resource packet, Nov 9, 1989.

# Scouting Songs

## Where Have all the Tigers Gone...

This is sung to the tune of "Where Have All the Flowers Gone?"

Where have all the Tigers gone, long time growing

Where have all the Tigers gone, in just a year

Where have all the Tigers gone,

Gone to Cub Scouts every one

They've got so much to learn,

They've got so much to learn.

Where have all the Cub Scouts gone, growing up so fast,

Where have all the Cub Scouts gone, it took three years.

Where have all the Cub Scouts gone,

Gone to Webelos every one.

There's still some more to learn,

There's still some more to learn.

Where have all the Webelos gone, no longer little boys,

Where have all the Webelos gone, fifth grade was last fall.

Where have all the Webelos gone

Gone to Boy Scouts every one.

It's a great adventure,

It's a great adventure.

Where have all the Boy Scouts gone, young men standing tall,

Where have all the Boy Scouts gone, eighteen draws near.

Where have all the Boy Scouts gone,

To fly with Eagles every one.

We love to be Boy Scouts,

We love to be BOY SCOUTS!

-- Thanks to Eyeleen, Orange Service Unit #3, Orange, California -- Cub Scout translation by Becky Shank, Webelos Leader, Pack 636, Great Western District, Greater Cleveland Council.

## Akela's Son

Sung to tune "Here Comes Peter Cottontail"

I've never seen a happier lad than one who's obeying his mother or dad.  
He doesn't talk back when he's told just what to do.  
I never have seen a happier lad  
than one who's obeying his mother or dad,  
But he jumps to his job with a snap and a click of his shoes.  
So be thankful for all that your mom or dad do,  
And do all you can to make them proud of you.  
You'll find your reward doing the things your told.  
So be thankful for all that your mom or dad do,  
And do all you can to make them proud of you.  
You'll find your reward, doing the things your told.  
So honor Akela in every way  
And you'll have many a happy day  
Your mom or dad will be so proud of you  
Just do your best in every way,  
And you'll have many a Happy day  
This is the promise that Akela brings to you.



### Quartermaster's Store

There are rats, rats, as big as alley cats,  
At the store, at the store.  
There are rats, rats, as big as alley cats,  
At the Quartermaster's store.

*Chorus:*

My eyes are dim, I can not see.  
I have not brought my specks with me. [Repeat.]

Mice . . . running through the rice.  
Snakes . . . as big as garden rakes.  
Beans . . . as big as submarines.  
Gravy . . . enough to float the navy.  
Cakes . . . that give us tummy aches.  
Eggs . . . with scaly chicken legs.  
Butter . . . running in the gutter.  
Lard . . . they sell it by the yard.  
Bread . . . with great big lumps like lead.  
Cheese . . . that makes you want to sneeze.  
Soot . . . they grow it by the foot.  
Goats . . . eating all the oats

Bees . . . with little knobby knees.  
Owls . . . shredding paper towels.  
Apes . . . eating all the grapes.  
Turtles . . . wearing rubber girdles.  
Bear . . . with curlers in its hair.  
Buffalos . . . with hair between their toes.  
Foxes . . . stuffed in little boxes.  
Coke . . . enough to make you choke.  
Pepsi . . . that gives you apoplexy.  
Roaches . . . sleeping in the coaches.  
Flies . . . swarming 'round the pies.  
Fishes . . . washing all the dishes.  
Moths . . . eating through the cloths  
Scouts . . . eating brussel sprouts.  
Leaders . . . slapping at the skeeters.

## **Pinewood Derby Racing Song**

Sung to tune "Take me out to the ball game"

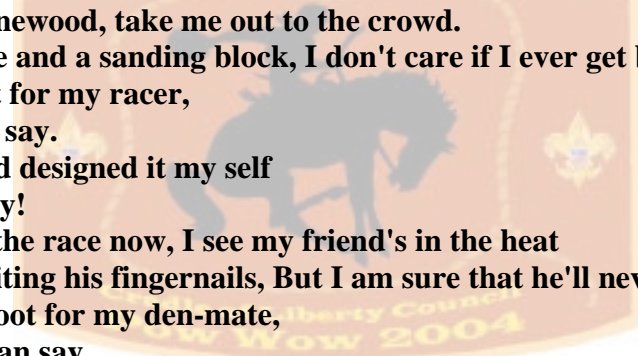

Take me out to the pinewood, take me out to the crowd.  
Buy me some graphite and a sanding block, I don't care if I ever get back.  
We will root root root for my racer,  
If I don't win you can say.  
That I cut, sanded and designed it my self  
In the Cub Scout Way!  
B'gosh their starting the race now, I see my friend's in the heat  
He's standing there biting his fingernails, But I am sure that he'll never be beat!  
For, We'll root root root for my den-mate,  
If he doesn't win we can say.  
That he cut, sanded, and designed it him self  
In the Cub Scout Way!  
The Scouts have declared a winner,  
And I am proud to say,  
My racer, it got to the end of the track,  
And my den leader let me bring it back,  
For a second heat in consolation,  
Was my decision today.  
But I cut, sanded, and designed it myself  
In the Cub Scout Way!

## I Wanna Be A Scout

Sung to tune "Achey Breakey Heart"

I wanna be a Scout,  
A true blue honest Scout,  
I thought my dad would understand.  
A real live Scout,  
A campin' trampin' Scout,  
Learning from Akela time and again.  
Webelos and Bear,  
Tiger and a Wolf,  
My Dad said I was joining a zoo.  
But, I wanna be a Scout,  
A true blue honest Scout,  
I know its the thing for me and you.  
We went on a hike,  
A nice long Scouting hike,  
A look at my dad showed he was blue.  
I asked how he felt,  
When he dropped down and knelt,  
And this is what I heard him mutter thru.  
"My achey breakey back,  
From my keester to my neck,  
Is tense and my muscles are hot too."  
"How do you go on,  
Without feeling like you've gone,  
A hundred miles with an ape on top of you."  
Cause I am a Scout,  
A biking hikin' Scout,  
I passed my advancement with no prob.  
I know how to hike,  
It's something that I like,  
I'm sorry that its got the best of you.  
We got back to camp,  
My dad still had his cramp,  
So I helped him get through our tent door.  
I went to get food,  
It would do him some good,  
And he started speaking clearly as he snored.  
"I wanna be a Scout,  
A true blue honest Scout,  
I thought my dad would understand."  
"A real live Scout,  
A campin' trampin' Scout,  
Learning from Akela time and again."

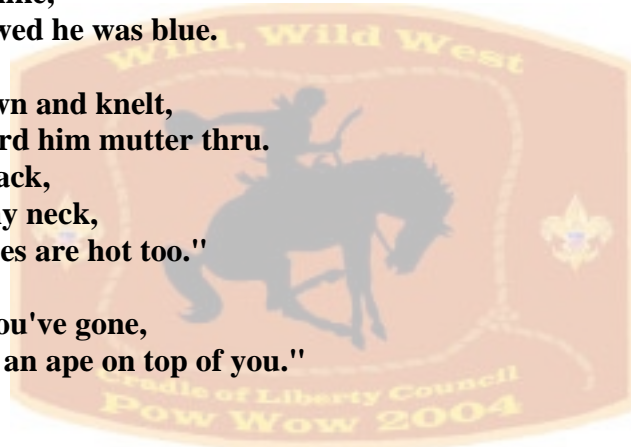

## Scout Wetspers

Tune: Scout Vespers (Oh, Tannenbaum)

Softly falls the rain today  
As our campsite floats away.  
Silently, each Scout should ask  
"Did I bring my SCUBA mask?  
Have I tied my tent flaps down?  
Learned to swim, so I won't drown?  
Have I done, and will I try  
Everything to keep me dry?"

-- Thanks to Chuck Bramlet

## Scouting "Do You Know What I Know"

Sung to tune "Do you hear what I hear"

Said the Tiger Cub to the Mighty Scout,  
"Do you know what I know?  
With my partner I just learned about,  
Do you know what I know?  
A promise, a promise is swirling in my head, It will bring us the world and fun.  
It will bring us the world and fun."  
Said the Wolf Cub to the Mighty Scout,  
"Do you hear what I hear?  
In my den I just learned about,  
Do you hear what I hear?  
A skit, a skit, is practised just for you, It will bring us experience and delight,  
It will bring us experience and delight."  
Said the Bear Cub to the Mighty Scout,  
"Have you made what I've made?  
In our shop just the other night,  
Have you made what I've made? A craft, a craft is sitting over there.  
It will bring us good skills to share,  
It will bring us good skills to share."  
Said the Webelos to the Mighty Scout,  
"Have you been where I've been?  
In the snow and in the warmth of Spring,  
Have you been where I've been? The camping, the food, our curiosity,  
We are strong to follow your path,  
We are strong to follow your path."  
Said the Mighty Scout to cubs gathered there,  
"Do you know what I know?  
In your dens Scouts everywhere,  
Do you know what I know? Your games, your work is shining in your face.  
You will grow to lead the rest,  
You will grow to do your best!

# Sing Old Sam

Sung to tune of "Auld Lang Syne"

Should old Cub Scouts, be forgot  
If no arrow points have they?  
Or should we burn a candle dear  
To light the Scouting way?  
A candle in the dark is bright.  
We feel its warmth and cheer.  
Like Scouting is to all of us,  
It is something we hold dear.  
A candle in the dark is bright.  
It gives us light of day.  
We'll burn a candle brightly dear  
To light the Scouting way.  
So do your best and be prepared.  
And recall the Scout law too!  
We've sung enough of this tonight  
But may Scouting stay with you.

## Pinewood Derby Songs and Yells

---

Part of the fun of a big event like the Pinewood Derby is showing spirit through participation. Most Cub Scouts have a few intense minutes in the limelight of competition, but spend most of their time spectating and rooting for their fellow Scouts. The entire experience can be enriched with a little audience participation in songs, stunts, or Den yells. Here are a few to get started.

### Pinewood Derby Song

(To the tune: De Camptown Races)

Cub Scouts all join in the song,  
Do-da, do-dah!  
Pine car track am mighty long,  
Oh, do-day-day!

#### Chorus:

Going to run so fast,  
Going to get ahead,  
Bet my money on a blue pine car,  
Somebody bet on the red.

Black cars, blue cars, green and gray,  
Do-da, do-da!  
Are running on the track today,  
Oh, do-da-day!

**Chorus:**

Going to run so fast,  
Going to get ahead,  
Bet my money on a blue pine car,  
Somebody bet on the red.

Pine cars do have lots of class,  
Do-da, Do-dah!  
Even though they don't use gas,  
Oh, do-da-day!

**Chorus:**

Going to run so fast,  
Going to get ahead,  
Bet my money on a blue pine car,  
Somebody bet on the red.

They're the pride of all the Dens,  
Do-da, do-da!  
Built by Cub Scouts and their friends,  
Oh, do-da-day!

**Chorus:**

Going to run so fast,  
Going to get ahead,  
Bet my money on a blue pine car,  
Somebody bet on the red.



**Den Yells**

**Do three times, starting out softly, and ending up really loud.**

We're from Den \_\_\_\_\_  
Couldn't be prouder.  
If you can't hear us,  
We'll yell a little louder.

**Do once, LOUD!**

United we stand.  
Divided we fall!  
Den \_\_\_\_\_  
Is best of all!



## Do once, LOUD!

Look out!  
Here we come.  
Den \_\_\_\_\_  
Is on the run!

## Do once, LOUD!

North, South,  
East or West,  
Den \_\_\_\_\_  
Is the best!

## (LOUD, with ACTION!)

Clap your hands!  
Stomp your feet!  
For Den \_\_\_\_\_  
Can't be beat!

## A Pinewood Derby Reading

When I make my car,  
I hope that I can win.  
Everything is ready,  
the weight & shine & spin.  
The first race is the real test,  
to see how good it is.  
My helper is happy too,  
you'd think the car is his!  
Eventually I lose a race,  
and it is hard to take,  
But my helper and I sure had fun,  
a Pinewood Derby car to make!



## The Big Race (Audience Participation)

Narrator reads the following like a radio announcer with a lot of enthusiasm! The audience is divided into groups. As their assigned word is read in the story, they make the sound:

- WHITE = Whiz!
- RED = Zoom!
- YELLOW = Zip!
- BLUE = Ca-Chunk!

The cars are ready.  
The flag us up.  
The race is set to go.  
The flag goes down,

The cars are off...  
They're running toe to toe!  
The white \_\_\_\_\_ is ahead.  
The red \_\_\_\_\_ goes by.  
Here comes the yellow \_\_\_\_\_ now.  
Here comes another one - it's blue \_\_\_\_\_.  
Whew, it sounds bad, wow!!  
The last lap now.  
The red \_\_\_\_\_ is leading,  
The yellow \_\_\_\_\_ and white \_\_\_\_\_ close behind.  
I'm looking hard -- I see the blue \_\_\_\_\_.  
So far back, it's hard to find!  
The finish line is just ahead.  
That blue \_\_\_\_\_ is coming up fast,  
I can't tell why ...  
The crowds on its feet ...  
They're yelling -  
The white \_\_\_\_\_, the red \_\_\_\_\_,  
The yellow \_\_\_\_\_, the blue \_\_\_\_\_,  
**HAVE ALL FINISHED IN A TIE!!**

This section has but a few of the countless songs that can enrich each meeting, campfire, get together. Try the following links for many, many more songs.



## Links

If you are online and hold down the control key and left click your mouse it will take you to these sites.

Some of these sites have links that will take you to other song sites. Enjoy!

[Grant's Scouting Songbook](#)

[Grant's Scouting Resources - Songs and Skits](#)

[Index](#)

[Clare's Cub Scout Songs Main Page](#)

[Links to Music Lyrics](#)

[Scout Songs Index](#)

[Songbook of Song Lyrics for Boy Scout Camp and Troop Meetings - Girl Scouts, Boy Scouts](#)

[Songs for Scouts to Sing](#)

# Songs

One of the hardest things about doing the sessions on songs for POW WOW is submitting material for the "book".

We felt this year we would include our resources, places that we have found over the years, sites that everyone knows plus some sites that may not be as well known.

This is not an all inclusive list since we have not been to every site there is (although my wife would swear that I spend enough time on the computer that I must have been to each site by now!)

We will still list some of our favorites, but please visit the sites we have included, to access the thousands of songs that you can do at any of your meetings.

## **Ah, that brings up a thought! Why do songs anyway?**

I like what Clair Mansfield had to say on her web site.  
<http://www.angelfire.com/oh/claremansfield/cubscoutsongs.html>

Why are songs important in Scouting? Well, in addition to being fun, they teach the boys the life skills of working together, and following directions, and also improve a boy's memorization, while he learns the words. The songs you teach your Cubs now, are one aspect of the program that they are not likely to forget when they themselves are adults, and they will pass these songs onto their children, creating a heritage and bond between generations. And, you thought songs were just for pleasure!

So, warm up your vocal cords, and remember the wise words we in Scouts live by when it comes to singing - "If you can't sing well, sing LOUD!" (I, sing loud )

You will find that the boys really enjoy the silliness or grossness of the lyrics, and forget that they thought singing was uncool. In fact, introducing silly and gross songs, may earn you the reputation for being a "Cool" leader.



I hope we can all be "cool" leaders. Thank you for giving us the chance to share some of what we have with you.

Barb Cuff

Joe Trafficante

John Rex

Here is a song that would make a great end to a meeting, campfire, or other gathering.

## AMERICA, AMERICA

[\(Download MIDI file\)](#)

(Suggested as campfire closing, recessional. Leader sings verse once, remainder join in for second, third, etc. time as group follows the leader out of the campfire area. After three or four times through, just hum the tune.)

A-mer-i-ca, A-mer-i-ca,  
How **can** I **tell** you **how** I **feel**?  
**You** have **giv-en** **me** your **trea-sures**,  
**I love** you **so**.

---

Return to [The Pope's Place](#)



## Kum Ba Yah

**Kum ba yah, my Lord, kum ba yah!**  
**Kum ba yah, my Lord, kum ba yah!**  
**Kum ba yah, my Lord, kum ba yah!**  
**Oh Lord, kum ba yah!**  
**Someone's sleeping, Lord . . .**  
**Someone's crying, Lord . . .**  
**Someone's singing, Lord . . .**  
**Someone's laughing, Lord . . .**  
**Someone's praying, Lord . . .**  
**Someone's Scouting, Lord . . .**  
**Someone's camping, Lord . . .**  
**Kum ba yah, my Lord, . . .**

# THE NIGHT THEY MADE THE FIRST CUB SCOUT

[\(Download MIDI file "firstcs.mid"\)](#)

**Ma**-ny years a-go **on** this ver-y **night**  
Some **peo**-ple ga-thered '**round** a **camp**-fire's **light**  
**Ev**-'ry-one was **say**-ing the **world** was in a **mess**  
**Not** e-nough **peo**-ple try-ing to **do** their **best**. (So...)

Chorus:

...They **took** a lit-tle **Blue**  
and they **took** a lit-tle **Gold**  
They **took** a lit-tle **boy** about **eight** years **old**  
**Turned** him a-**round** and **lo** and be-**hold**  
**That's** how it **came** a-**bout**  
The **night** they made the **first** Cub **Scout**.

Now they **come** in ev-'ery **size**, they **come** in ev'ry **shape**  
And **ev**-'ry-where they **are**, the **world's** a bet-ter **place**  
Ev-'ry **Bob**-cat and **Bear**, ev-'ry **Wolf** and We-be-**los**  
Re-**mem**-bers that **night** ma-ny years a-go. (When...)

(Repeat chorus)

**Ti**-ger Cubs are **new**, the **boys** aren't ve-ry **old**  
You **know** it won't be **long** be-fore they **wear** the blue and **gold**  
To **Search**, Dis-co-ver, **Share** with their **par**-ents in **tow**  
**Hea**-ded down the **path** that star-**ted** years a-go. (When...)

(Repeat Chorus)

**Lea**-ders are the **ones** who **make** the pro-gram **go**  
And **Trai**-ners are the **ones** to put the **lea**-ders in the **know**  
How the **Pro**-mise and the **Law** help the **Cub** Scout **Grow**  
And **Blos**-som on the **trail** that star-**ted** years a-go. (When...)

(Repeat Chorus)

Oh, yes, ...

(Repeat Chorus)

From [The Pope's Place](#)

## Songs for special occasions

### Grace

#### Blessings Of This Day

(Tune: "Gilligan's Island" Theme)

We thank Thee, Lord for giving us  
The blessings of this day;  
For friends and food and family,  
And showing us the way.  
The bounty that you set before  
Us, proves to us you care.  
We praise you, Lord, for showing us  
Your presence everywhere.  
So, join us at this table, Lord,  
As we prepare to dine.  
All that we have is sent from you;  
And all we have is thine.

(Lyrics copyrighted 1996 by Clare Mansfield, GWRC)



#### Alphabet Grace

(Tune: 1st 2 lines of "Alphabet Song")

A-B-C-D-E-F-G  
Thank you, God for feeding me.

#### God Is Great God Is Good

(Tune: "Michael Row The Boat")

God is great, God is good, Alleluia.  
Let us thank Him for our food, Alleluia.  
By His hand we all are fed, Alleluia.  
Thank you, Lord, for daily bread, Alleluia

# Repeat Songs

## Boom Chicka Boom

I said a-boom-chick-a-boom! [Group echoes.]  
I said a-boom-chick-a-boom! [Group echoes.]  
I said a-boom-chick-a-rock-a-chick-a-rock-a-chick-a-boom!  
[Group echoes.]

Uh-huh! [Group echoes.]  
On Yeah! [Group echoes.]  
This time! [Group echoes.]  
We sing! [Group echoes.]  
**HIGHER!**

Each time a leader adds a different variation such as: **LOWER, WHISPER, LOUDER, TONGUE-IN-CHEEK, SEXY, GROOVY (COOL).**



## Goin' On a Lion Hunt

Audience echos each line. You can also have audience sets up clap or slap legs to the rhythm

Goin' on a lion hunt.  
Goin to catch a big one.  
I'm not afraid.  
Look, what's up ahead?  
Mud!  
Can't go over it.  
Can't go under it.  
Can't go around it.  
Gotta go through it. [Make sloshing sounds and move hands as if slogging.]

Following verses:

Sticks. [Snap fingers.]  
Tree. [Make gestures climbing up and down.]  
Gate. [Make gate-opening gestures.]  
River. [make swimming gestures.]  
Cave. [Go in it and find lion. Reverse all motions quicky to get home.]

-- Thanks to Delmont Scout Reservation and Resica Falls Scout Reservation 1996  
Songbook

## Froggie

The leader or leaders begin this song by starting the tempo by slapping their thighs then clapping their hands. Then yell the following. Remember - this is an echo song.

This is a repeat after me song

This is a repeat after me song (audience echo)

(body)

Dog

Dog (audience echo)

Dog - Cat

Dog - Cat (audience echo)

Dog - Cat - Mouse

Dog - Cat - Mouse (audience echo)

Froggie

Froggie (audience echo)

Itty Bitty teeny weenie little greenie frogie

Itty Bitty teeny weenie little greenie frogie (audience echo)

Jump, jump, jump little froggie

Jump, jump, jump little froggie (audience echo)

Little greenie froggie eating all the bugs and spiders

Little greenie froggie eating all the bugs and spiders (audience echo)

Fleas and flies are scrumpditllyitious

Fleas and flies are scrumpditllyitious (audience echo)

Ribit ribit ribit ribit ribit ribit CROAK !

Ribit ribit ribit ribit ribit ribit CROAK ! (audience echo)

(pause)

**FASTER !** (speed up the tempo)

**FASTER !** (audience echo)

(repeat body)

(pause)

**CUB SCOUT SPEED !!** (*speed up the tempo*)

**CUB SCOUT SPEED !!** (*audience echo*)

(*repeat body*)

(*pause*)

**SUPER CUB SCOUT SPEED !!!!** (Heres the tricky one)

**SUPER CUB SCOUT SPEED !!!!** (*audience echo*)

Dog croak ! (*one slap "Dog", One clap "Croak"*)

(*After a few times the audience will get SUPER CUB SCOUT SPEED*)

-- Thanks to David M. Sanchez, Cubmaster, Pack 265, San Jose, Ca.



## I've Got That Scouting Spirit

I've got that Scouting spirit up in my head,  
up in my head, up in my head.

I've got that Scouting spirit up in my head,  
up in my head to stay.

2. I've got that Scouting spirit deep in my heart.

3. I've got that Scouting spirit down in my feet.

4. I've got that Scouting spirit all over me.



## The Cat Came Back

Old man Johnson had troubles of his own.  
Had a little cat that wouldn't leave him alone.  
He tried and tried to give him away,  
He gave him to a man going far, far away.

**CHORUS:**

But the cat came back, the very next day.  
But the cat came back, they thought he was a goner,  
But the cat came back, he just couldn't stay away, away, away.

He gave it to a man going up in a bal.  
Told him to give it to the man in the moon  
The bal. came down about 20 miles away  
And where that man is we just can't say.

(Chorus)

He gave him to a boy with a dollar note,  
Told him to take up the river in a boat,  
Tied a rock round its neck must have weighed a hundred pounds,  
And now they're dredging the river for the little boy who drowned.

(Chorus)

He gave him to a man going way, way out west,  
Told him to give it to the one he favored best,  
First the train jumped track, then it hit the rail,  
And no one is alive today to tell the gruesome tale.

(Chorus)

Old man Johnson said he'd shoot that cat on sight,  
So he loaded up his shotgun with nails and dynamite.  
He waited and waited for that cat to come around,  
But ninety seven pieces of the man were all they ever found

(Chorus)

The H-bomb fell just the other day,  
The A-bomb fell in the very same way,  
Russia went, China went, and the USA  
The human race was destroyed without a chance to pray.

## Fast Food

Tune: A ram sam Sam

Pizza Hut a Pizza Hut  
Kentucky Fried Chicken and a Pizza Hut  
Pizza Hut a Pizza Hut  
Kentucky Fried Chicken and a Pizza Hut  
McDonald McDonalds  
Kentucky Fried Chicken and a Pizza Hut

A Burger King a Burger King  
Long John Silvers and a Burger King  
A Burger King a Burger King  
Long John Silvers and a Burger King  
Red Lobster Red Lobster  
Long John Silvers and a Burger King

Dairy Queen A Dairy Queen  
Chucky Cheese and a Dairy Queen  
Dairy Queen A Dairy Queen  
Chucky Cheese and a Dairy Queen  
Roy Rogers Roy Rogers  
Chucky Cheese and a Dairy Queen

### *Actions*

Pizza Hut - Make shape of a hut in the air  
Kentucky Fried- Flap elbows up and down in the manner of a demented chicken  
McDonalds - Put hands on top of head and bridge out and down to produce the "Golden Arches"  
Burger King - Put hands on head with fingers up to make a crown  
Long John Silver - mimic sword play  
Red Lobster - hold up arms and bring fingers down on thumbs like lobster claws snapping  
Dairy Queen - mimic milking a cow  
Chucky Cheese - mimic throwing up a pizza  
Roy Rogers - mimic riding a horse



## If I Weren't a Boy Scout ...

[Tune: This is the Music Concert]

If I were not a Boy Scout, I wonder what I'd be

If I were not a Boy Scout, a .....

1. A bird watcher I'd be

Hark a lark, flying through the park, SPLAT!

2. A plumber I would be

Plunge it, flush it, look out below!

3. A mermaid I would be

Bloop, bloop, bloop, bloop, bloop, bloop!

4. A carpenter I'd be

Two by four, nail it to the floor!

5. A secretary I'd be

z-z-z-z get the point, z-z-z-z get the point?

6. A teacher I would be

Sit down, shut up, throw away your gum!

7. An airline attendant I'd be

Coffee, tea, or me, sir; here's your little bag, BLEH!

8. A typist I would be

Ticka, ticka, ticka, ticka, ticka, ticka, ZING!

9. A hippie I would be

Love and peace, my hair is full of grease!

[or] Hey Man! Cool Man! Far out! Wow!

10. A farmer I would be

Here's a cow, there's a cow, and here's another yuck!

[or] Come on Betsy give... the baby's gotta live

11. A laundry worker I would be

Starchy here, starchy there, starchy in your underwear!

12. A cashier I would be

Twenty nine, forty nine, here is your change, sir!

13. A gym teacher I'd be



**We must, we must, improve the bust!**

**14. A medic I would be  
Turn around, drop your pants, jab, jab, jab!**

**15. A doctor I would be  
Take a pill; pay my bill! I'm going golfing!  
[or] Needle! Thread! Stick 'em in the head!**

**16. An electrician I would be  
Positive, negative bzzzzt zap**

**17. A fireman I would be  
Jump lady, jump... whoa spat!**

**18. A cook I would be  
Mix it, bake it; heartburn-BURP!**

**19. A ice cream maker I'd be  
Tutti-frutti, tutti-frutti, nice ice cream!**

**20. A politician I would be  
Raise the taxes, lower the pay, vote for me on election day!**

**21. A butcher I would be  
Chop it up, grind it up, make a little patty!**

**22. A garbage collector I'd be  
Lift it, dump it, pick out the good stuff  
[or] Pile that garbage. Pile that garbage. Pile it to the sky.**

**23. A [Domino's] pizza maker I'd be  
30 minute, fast delivery!**

**24. A clam digger I would be  
Dig one here, dig one there-Oh my frozen derriere!**

**25. Superman I would be  
It's a bird, it's a plane, where is Lois Lane?**

**26. Lois Lane I would be  
Get away, get away, get away, Clark Kent!**

**27. A cyclist I would be  
peddle, peddle, peddle, peddle; ring, ring, ring!**

28. A truck driver I'd be  
Here's a curve, there's a curve. HERE'S A BETTER CURVE!  
[Makes outline of shapely woman.]
29. A house cleaner I'd be  
Ooh, a bug; squish it in the rug!
30. A baby I would be  
Mama, Dada, I wuv you!
31. A Preacher I would be  
Well, well, you never can tell; you might go to heaven, or you might go to ...
32. A DJ I would Be,  
Miles of smiles on the radio dial.
33. A Stewardess I would be,  
Here's your coffee, here's your tea. here's your paper bag, urrrp
34. A Baker I would be,  
Donuts! Eclairs! Buy My Buns!
35. A Lifeguard I would be,  
Save yourself, Man. I'm working on my tan!  
[or] Mouth to Mouth Resuscitate, What a way to get a date.
36. A Lawyer I would be,  
Honest. I swear, My client wasn't there
37. An Undertaker I would be,  
6 x 4, nail them to the floor.
38. An Engineer, I would be,  
Push the button, push the button, kick the darn machine.
39. A Ranger I would be,  
Get eaten by a bear, see if I care.
40. A Scoutmaster I would be,  
Do this, do that, I'm gonna take a nap.
- Finally: A Girl Scout I would be!

# Silly Holiday Songs

## A Scout's Christmas

By K. Meyers, D. Busker, and the boys of Den 4, Pack 1515, Alexandria, VA  
(tune: Jingle Bells)

Dashing through the den,  
With a rope held by each end,  
Tying a bowline knot  
Then showing what I've got.

Whittling with my knife  
On a practice Dial soap bar.  
I can hardly wait,  
Scout camp can't be far.

Bait a hook,  
Learn to cook,  
Bike ro-de-os.  
Neckerchief slides,  
Canned food drives,  
Learning to take photos.

Pancake mix,  
Carving sticks,  
Keeps us on the run.  
Our families  
Make all these  
Memories so much fun.

Dashing through the camp,  
Putting up the tents,  
Popping all the corn,  
Blowing that morning horn.

Of scout camp we all dream  
We'll soon be old enough  
Tigers, Bobcats, Wolves, and Bears  
We're made of real tough stuff!

Half-hitch knots,  
Setting up cots,



Playing fun new games.  
Hammers and nails,  
Compass and trails,  
Arrow points are the thing.

Santa's coming,  
We've been good,  
As good as we can be...  
Load our stocking  
With a pocket knife,  
Boy Scouts we want to be!

-- Thanks to Pete Farnham, CM, Pack 1515, GW District, NCAC, Alexandria, VA

## The Twelve Scouting Days of Christmas

(Tune: 12 Days of Christmas. Substitute Christmas for Scouting in the leading lines as you wish)

On the first day of Scouting, Akela gave to me.....

A Den Leader swinging from a tree!

On the second day of Scouting, Akela gave to me.....

Two Screaming Bobcats,

And a Den Leader swinging from a tree!

*OK, you should have the idea by now. Here's the rest of these silly verses:*

**Third Day**

Three Skinny Wolves

**Fourth Day**

Four Hungry Bears

**Fifth Day**

Five We be los

**Sixth Day**

Six Arrow points

**Seventh Day**

Seven Silly Den Chiefs

**Eighth Day**

Eight Shouting Scouts

**Ninth Day**



**Nine Warring Eagles**

**Tenth Day**

**Ten Derby Cars**

**Eleventh Day**

**Eleven Funny Den Skits**

**Twelfth Day**

**Twelve Wacky Cheers**

-- Thanks to Jack W. Weinmann

## **"I'm A Snowflake" by Karen Rogers**

**Tune: Clementine**

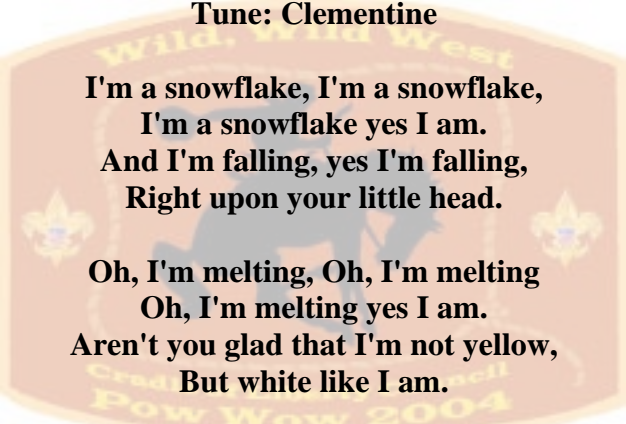

**I'm a snowflake, I'm a snowflake,  
I'm a snowflake yes I am.  
And I'm falling, yes I'm falling,  
Right upon your little head.**

**Oh, I'm melting, Oh, I'm melting  
Oh, I'm melting yes I am.  
Aren't you glad that I'm not yellow,  
But white like I am.**

--Thanks to Chuck Bramlet, ASM Troop 323, Thunderbird District, Grand Canyon Council, Phoenix, Az. and the Thunderbird District, TRC, Cub Scout Roundtable resource packet, Nov 9, 1989.

# Scouting Songs

## Where Have all the Tigers Gone...

This is sung to the tune of "Where Have All the Flowers Gone?"

Where have all the Tigers gone, long time growing

Where have all the Tigers gone, in just a year

Where have all the Tigers gone,

Gone to Cub Scouts every one

They've got so much to learn,

They've got so much to learn.

Where have all the Cub Scouts gone, growing up so fast,

Where have all the Cub Scouts gone, it took three years.

Where have all the Cub Scouts gone,

Gone to Webelos every one.

There's still some more to learn,

There's still some more to learn.

Where have all the Webelos gone, no longer little boys,

Where have all the Webelos gone, fifth grade was last fall.

Where have all the Webelos gone

Gone to Boy Scouts every one.

It's a great adventure,

It's a great adventure.

Where have all the Boy Scouts gone, young men standing tall,

Where have all the Boy Scouts gone, eighteen draws near.

Where have all the Boy Scouts gone,

To fly with Eagles every one.

We love to be Boy Scouts,

We love to be BOY SCOUTS!

-- Thanks to Eyeleen, Orange Service Unit #3, Orange, California -- Cub Scout translation by Becky Shank, Webelos Leader, Pack 636, Great Western District, Greater Cleveland Council.

## Akela's Son

Sung to tune "Here Comes Peter Cottontail"

I've never seen a happier lad than one who's obeying his mother or dad.  
He doesn't talk back when he's told just what to do.  
I never have seen a happier lad  
than one who's obeying his mother or dad,  
But he jumps to his job with a snap and a click of his shoes.  
So be thankful for all that your mom or dad do,  
And do all you can to make them proud of you.  
You'll find your reward doing the things your told.  
So be thankful for all that your mom or dad do,  
And do all you can to make them proud of you.  
You'll find your reward, doing the things your told.  
So honor Akela in every way  
And you'll have many a happy day  
Your mom or dad will be so proud of you  
Just do your best in every way,  
And you'll have many a Happy day  
This is the promise that Akela brings to you.



### Quartermaster's Store

There are rats, rats, as big as alley cats,  
At the store, at the store.  
There are rats, rats, as big as alley cats,  
At the Quartermaster's store.

*Chorus:*

My eyes are dim, I can not see.  
I have not brought my specks with me. [Repeat.]

Mice . . . running through the rice.  
Snakes . . . as big as garden rakes.  
Beans . . . as big as submarines.  
Gravy . . . enough to float the navy.  
Cakes . . . that give us tummy aches.  
Eggs . . . with scaly chicken legs.  
Butter . . . running in the gutter.  
Lard . . . they sell it by the yard.  
Bread . . . with great big lumps like lead.  
Cheese . . . that makes you want to sneeze.  
Soot . . . they grow it by the foot.  
Goats . . . eating all the oats

Bees . . . with little knobby knees.  
Owls . . . shredding paper towels.  
Apes . . . eating all the grapes.  
Turtles . . . wearing rubber girdles.  
Bear . . . with curlers in its hair.  
Buffalos . . . with hair between their toes.  
Foxes . . . stuffed in little boxes.  
Coke . . . enough to make you choke.  
Pepsi . . . that gives you apoplexy.  
Roaches . . . sleeping in the coaches.  
Flies . . . swarming 'round the pies.  
Fishes . . . washing all the dishes.  
Moths . . . eating through the cloths  
Scouts . . . eating brussel sprouts.  
Leaders . . . slapping at the skeeters.

## **Pinewood Derby Racing Song**

Sung to tune "Take me out to the ball game"

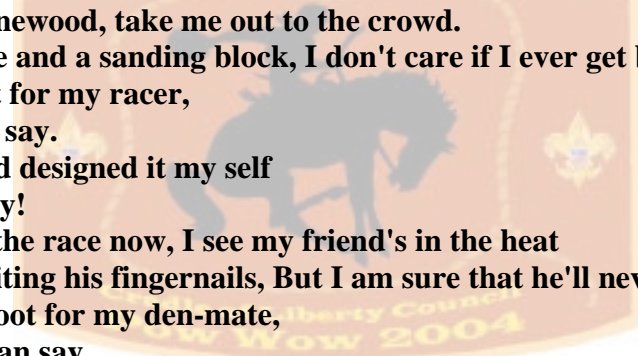

Take me out to the pinewood, take me out to the crowd.  
Buy me some graphite and a sanding block, I don't care if I ever get back.  
We will root root root for my racer,  
If I don't win you can say.  
That I cut, sanded and designed it my self  
In the Cub Scout Way!  
B'gosh their starting the race now, I see my friend's in the heat  
He's standing there biting his fingernails, But I am sure that he'll never be beat!  
For, We'll root root root for my den-mate,  
If he doesn't win we can say.  
That he cut, sanded, and designed it him self  
In the Cub Scout Way!  
The Scouts have declared a winner,  
And I am proud to say,  
My racer, it got to the end of the track,  
And my den leader let me bring it back,  
For a second heat in consolation,  
Was my decision today.  
But I cut, sanded, and designed it myself  
In the Cub Scout Way!

## I Wanna Be A Scout

Sung to tune "Achey Breakey Heart"

I wanna be a Scout,  
A true blue honest Scout,  
I thought my dad would understand.  
A real live Scout,  
A campin' trampin' Scout,  
Learning from Akela time and again.  
Webelos and Bear,  
Tiger and a Wolf,  
My Dad said I was joining a zoo.  
But, I wanna be a Scout,  
A true blue honest Scout,  
I know its the thing for me and you.  
We went on a hike,  
A nice long Scouting hike,  
A look at my dad showed he was blue.  
I asked how he felt,  
When he dropped down and knelt,  
And this is what I heard him mutter thru.  
"My achey breakey back,  
From my keester to my neck,  
Is tense and my muscles are hot too."  
"How do you go on,  
Without feeling like you've gone,  
A hundred miles with an ape on top of you."  
Cause I am a Scout,  
A biking hikin' Scout,  
I passed my advancement with no prob.  
I know how to hike,  
It's something that I like,  
I'm sorry that its got the best of you.  
We got back to camp,  
My dad still had his cramp,  
So I helped him get through our tent door.  
I went to get food,  
It would do him some good,  
And he started speaking clearly as he snored.  
"I wanna be a Scout,  
A true blue honest Scout,  
I thought my dad would understand."  
"A real live Scout,  
A campin' trampin' Scout,  
Learning from Akela time and again."

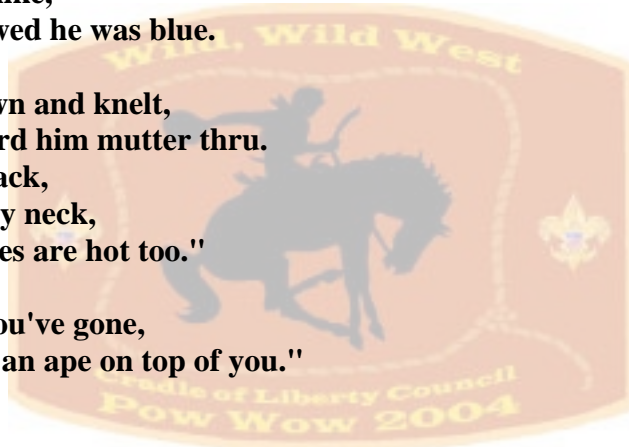

## Scout Wetspers

Tune: Scout Vespers (Oh, Tannenbaum)

Softly falls the rain today  
As our campsite floats away.  
Silently, each Scout should ask  
"Did I bring my SCUBA mask?  
Have I tied my tent flaps down?  
Learned to swim, so I won't drown?  
Have I done, and will I try  
Everything to keep me dry?"

-- Thanks to Chuck Bramlet

## Scouting "Do You Know What I Know"

Sung to tune "Do you hear what I hear"

Said the Tiger Cub to the Mighty Scout,  
"Do you know what I know?  
With my partner I just learned about,  
Do you know what I know?  
A promise, a promise is swirling in my head, It will bring us the world and fun.  
It will bring us the world and fun."  
Said the Wolf Cub to the Mighty Scout,  
"Do you hear what I hear?  
In my den I just learned about,  
Do you hear what I hear?  
A skit, a skit, is practised just for you, It will bring us experience and delight,  
It will bring us experience and delight."  
Said the Bear Cub to the Mighty Scout,  
"Have you made what I've made?  
In our shop just the other night,  
Have you made what I've made? A craft, a craft is sitting over there.  
It will bring us good skills to share,  
It will bring us good skills to share."  
Said the Webelos to the Mighty Scout,  
"Have you been where I've been?  
In the snow and in the warmth of Spring,  
Have you been where I've been? The camping, the food, our curiosity,  
We are strong to follow your path,  
We are strong to follow your path."  
Said the Mighty Scout to cubs gathered there,  
"Do you know what I know?  
In your dens Scouts everywhere,  
Do you know what I know? Your games, your work is shining in your face.  
You will grow to lead the rest,  
You will grow to do your best!

# Sing Old Sam

Sung to tune of "Auld Lang Syne"

Should old Cub Scouts, be forgot  
If no arrow points have they?  
Or should we burn a candle dear  
To light the Scouting way?  
A candle in the dark is bright.  
We feel its warmth and cheer.  
Like Scouting is to all of us,  
It is something we hold dear.  
A candle in the dark is bright.  
It gives us light of day.  
We'll burn a candle brightly dear  
To light the Scouting way.  
So do your best and be prepared.  
And recall the Scout law too!  
We've sung enough of this tonight  
But may Scouting stay with you.

## Pinewood Derby Songs and Yells

---

Part of the fun of a big event like the Pinewood Derby is showing spirit through participation. Most Cub Scouts have a few intense minutes in the limelight of competition, but spend most of their time spectating and rooting for their fellow Scouts. The entire experience can be enriched with a little audience participation in songs, stunts, or Den yells. Here are a few to get started.

### Pinewood Derby Song

(To the tune: De Camptown Races)

Cub Scouts all join in the song,  
Do-da, do-dah!  
Pine car track am mighty long,  
Oh, do-day-day!

#### Chorus:

Going to run so fast,  
Going to get ahead,  
Bet my money on a blue pine car,  
Somebody bet on the red.

Black cars, blue cars, green and gray,  
Do-da, do-da!  
Are running on the track today,  
Oh, do-da-day!

**Chorus:**

Going to run so fast,  
Going to get ahead,  
Bet my money on a blue pine car,  
Somebody bet on the red.

Pine cars do have lots of class,  
Do-da, Do-dah!  
Even though they don't use gas,  
Oh, do-da-day!

**Chorus:**

Going to run so fast,  
Going to get ahead,  
Bet my money on a blue pine car,  
Somebody bet on the red.

They're the pride of all the Dens,  
Do-da, do-da!  
Built by Cub Scouts and their friends,  
Oh, do-da-day!

**Chorus:**

Going to run so fast,  
Going to get ahead,  
Bet my money on a blue pine car,  
Somebody bet on the red.



**Den Yells**

**Do three times, starting out softly, and ending up really loud.**

We're from Den \_\_\_\_\_  
Couldn't be prouder.  
If you can't hear us,  
We'll yell a little louder.

**Do once, LOUD!**

United we stand.  
Divided we fall!  
Den \_\_\_\_\_  
Is best of all!



## Do once, LOUD!

Look out!  
Here we come.  
Den \_\_\_\_\_  
Is on the run!

## Do once, LOUD!

North, South,  
East or West,  
Den \_\_\_\_\_  
Is the best!

## (LOUD, with ACTION!)

Clap your hands!  
Stomp your feet!  
For Den \_\_\_\_\_  
Can't be beat!

## A Pinewood Derby Reading

When I make my car,  
I hope that I can win.  
Everything is ready,  
the weight & shine & spin.  
The first race is the real test,  
to see how good it is.  
My helper is happy too,  
you'd think the car is his!  
Eventually I lose a race,  
and it is hard to take,  
But my helper and I sure had fun,  
a Pinewood Derby car to make!



## The Big Race (Audience Participation)

Narrator reads the following like a radio announcer with a lot of enthusiasm! The audience is divided into groups. As their assigned word is read in the story, they make the sound:

- WHITE = Whiz!
- RED = Zoom!
- YELLOW = Zip!
- BLUE = Ca-Chunk!

The cars are ready.  
The flag us up.  
The race is set to go.  
The flag goes down,

The cars are off...  
They're running toe to toe!  
The white \_\_\_\_\_ is ahead.  
The red \_\_\_\_\_ goes by.  
Here comes the yellow \_\_\_\_\_ now.  
Here comes another one - it's blue \_\_\_\_\_.  
Whew, it sounds bad, wow!!  
The last lap now.  
The red \_\_\_\_\_ is leading,  
The yellow \_\_\_\_\_ and white \_\_\_\_\_ close behind.  
I'm looking hard -- I see the blue \_\_\_\_\_.  
So far back, it's hard to find!  
The finish line is just ahead.  
That blue \_\_\_\_\_ is coming up fast,  
I can't tell why ...  
The crowds on its feet ...  
They're yelling -  
The white \_\_\_\_\_, the red \_\_\_\_\_,  
The yellow \_\_\_\_\_, the blue \_\_\_\_\_,  
**HAVE ALL FINISHED IN A TIE!!**

This section has but a few of the countless songs that can enrich each meeting, campfire, get together. Try the following links for many, many more songs.



## Links

If you are online and hold down the control key and left click your mouse it will take you to these sites.

Some of these sites have links that will take you to other song sites. Enjoy!

[Grant's Scouting Songbook](#)

[Grant's Scouting Resources - Songs and Skits](#)

[Index](#)

[Clare's Cub Scout Songs Main Page](#)

[Links to Music Lyrics](#)

[Scout Songs Index](#)

[Songbook of Song Lyrics for Boy Scout Camp and Troop Meetings - Girl Scouts, Boy Scouts](#)

[Songs for Scouts to Sing](#)