

**OLD BALDY
COUNCIL
PRESENTS**

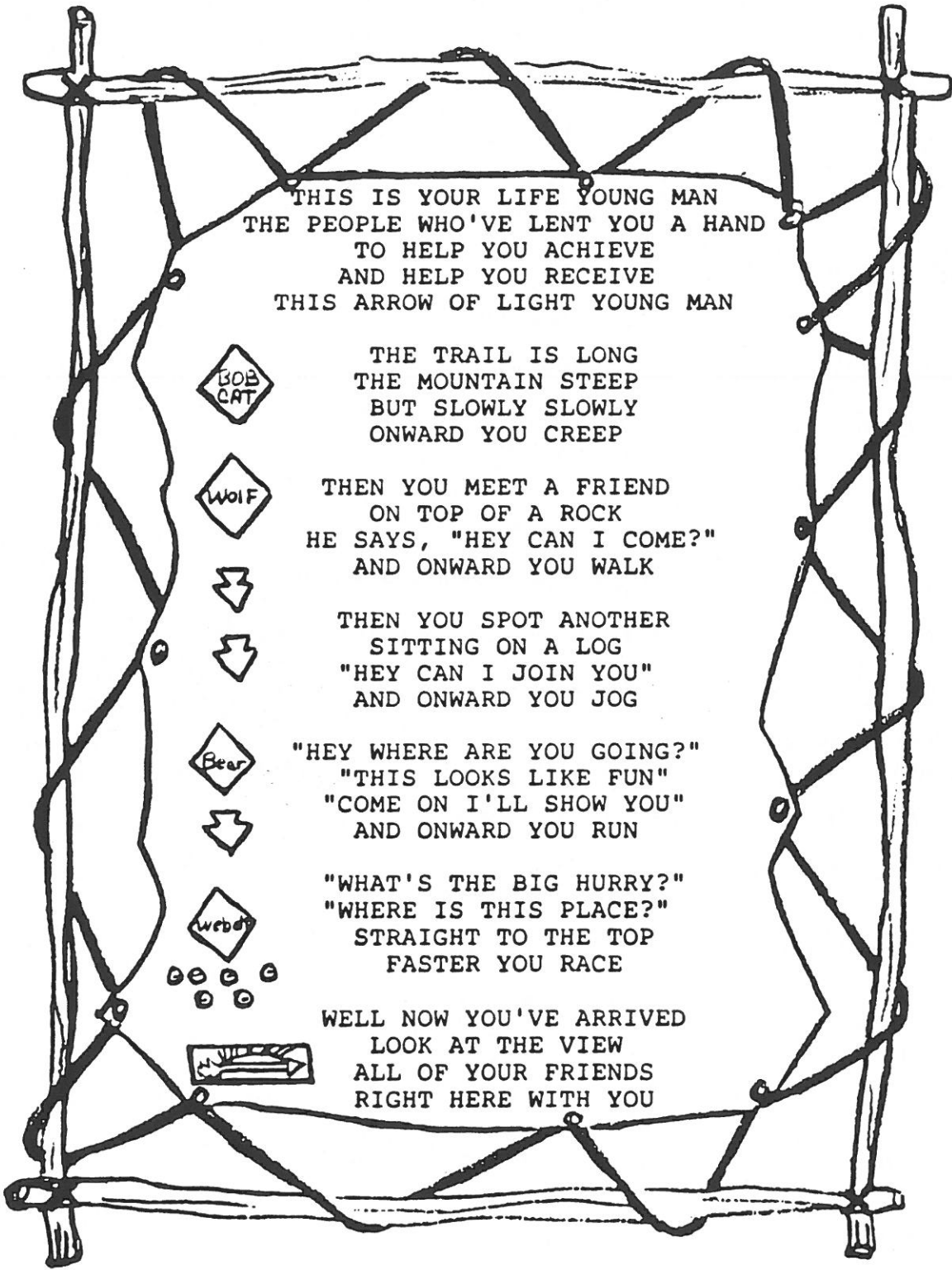

**POW WOW
1989**



THIS IS YOUR LIFE YOUNG MAN
THE PEOPLE WHO'VE LENT YOU A HAND
TO HELP YOU ACHIEVE
AND HELP YOU RECEIVE
THIS ARROW OF LIGHT YOUNG MAN

THE TRAIL IS LONG
THE MOUNTAIN STEEP
BUT SLOWLY SLOWLY
ONWARD YOU CREEP

THEN YOU MEET A FRIEND
ON TOP OF A ROCK
HE SAYS, "HEY CAN I COME?"
AND ONWARD YOU WALK

THEN YOU SPOT ANOTHER
SITTING ON A LOG
"HEY CAN I JOIN YOU"
AND ONWARD YOU JOG

"HEY WHERE ARE YOU GOING?"
"THIS LOOKS LIKE FUN"
"COME ON I'LL SHOW YOU"
AND ONWARD YOU RUN

"WHAT'S THE BIG HURRY?"
"WHERE IS THIS PLACE?"
STRAIGHT TO THE TOP
FASTER YOU RACE

WELL NOW YOU'VE ARRIVED
LOOK AT THE VIEW
ALL OF YOUR FRIENDS
RIGHT HERE WITH YOU

POEM BY: GERALD N. GALBRAITH II

1989 OLD BALDY STAFF ROSTER

Co-Chairman	Michael J. Raab George Lee
Budget & Admin	Barbara Reynolds
Crafts Div.	Norma Bergman
Midway	Phil Tate Gary Galbraith
Physical Arrang.	Sue Prior
Pow Wow Book	Marla Lefler
Professional Adv.	Bill Gruber
Registration	Sue Prior Barbara Reynolds

CLASSES

Songs:	Karen Zuk & Bobbie Hoffman
Pizazz	Sue Navarro & Charlotte Bemis
Magic	Mel Autrey
Costumes on No Budget	Doug Bennett & Harry Beagle
Leather Craft	Frank Miller
Neckerchief Slide Craft	Jimmie Ramirez
Holiday Crafts	Karen Zuk & Bobbie Hoffman
Paper Craft	Norma Johnson
Games	Wes Mitchell
Puppets	Sharon & Gary Galbraith
Ceremonies	Gary & Sharon Galbraith
Cub Scout High Adventure	Dan Manhart
Pack Administration	Bill Bergman
Webelos Den Program	Jeff Wanland

POW WOW THEMES
AND
ACTIVITY BADGES

JANUARY	Invention Convention Handyman/Readyman
FEBRUARY	Mardi Gras Scholar/Engineer
MARCH	Achievement Parade Naturalist/Engineer
APRIL	Mountains of America Geologist/Family Member
MAY	Under the Big Top Outdoorsman/Showman
JUNE	Sports Arena Naturalist/Athlete
JULY	Buckskin Pioneers Aquanaut/Forester
AUGUST	Harbors, Stations, an Airports Traveler/Artist
SEPTEMBER	Explore your Neighborhood Communicator/Scientist
OCTOBER	Land of Make Believe Fitness/Scientist
NOVEMBER	Heroes in Books Craftsman/Citizen
DECEMBER	Giving Gifts Craftsman/Citizen

STAFF OPENING SKIT

A MOO MOO MELODRAMA
(WITH APOLOGIES TO GILBERT AND SULLIVAN)

THIS IS A FAST MOO-VING ONE ACT PLAY, DESIGNED FOR AMATEUR HOOFERS, THAT CUD UDDERLY DELIGHT ANDY CROWD FROM HOLSTEIN TO JERSEY.

THE PLAYERS

THE COWS - THREE HEFFERS IN CATTLE CHORUS

THE MOM -A STURDY FRONTIER WOMAN AT THE END OF HER ROPE FOR LACK OF HAY....AWWW!

THE SON - A CHEESY YOUTH OF DUBIOUS FORTITUDE.

THE DAUGHTER - A CREAMY YOUNG MAIDEN WHO RADIATES SWEETNESS AND PURITY....AAHH!

THE VILLAIN - A SERPENTINE DASTARD WHO IS BULLISH ON OTHER PEOPLE'S MISFORTUNE....BOOO!

THE HERO - A STALWART YOUNG MAN THROUGH WHOSE VEINS FLOWS THE MILK OF HUMAN KINDNESS...OOHH!

THE SETTING

MOM'S FARM, WHERE TRUE HAPPINESS IS TO BE UPWIND OF THE COWS, AND NO ONE, EXCEPT THE HERO, IS IN THE CHIPS. COWS ARE GRAZING STAGE LEFT, WHILE MOM LAMENTS STAGE RIGHT.

COWS: A MOO, A MOO, A MOO MOO MOO,
I SAID A MOO, A MOO, A MOO MOO MOO.

MOM: A BOO, A BOO, A BOO HOO HOO,
I SAID A BOO, A BOO, A BOO HOO HOO.

(SON ENTERS)

SON: WHAT'S THE MATTER MA, WHY 'YA CRYIN' SO?
I SAID WHAT'S THE MATTER MA, WHY 'YA CRYIN' SO?

MOM: I AIN'T GOT THE MONEY FOR THE MORTGAGE ON THE COWS, I SAID I AIN'T GOT THE MONEY FOR THE MORTGAGE ON THE COWS.

MOM & SON: A BOO, A BOO, A BOO HOO HOO,
I SAID A BOO, A BOO, A BOO HOO HOO.

COWS: A MOO, A MOO, A MOO MOO MOO,
I SAID A MOO, A MOO, A MOO MOO MOO.

(DAUGHTER ENTERS)

DAUGHTER: WHAT'S THE MATTER MA, WHY 'YA CRYIN' SO?
I SAID WHAT'S THE MATTER MA, WHY 'YA CRYIN' SO?

MOM: I AIN'T GOT THE MONEY FOR THE MORTGAGE ON THE
COWS. I SAID, I AIN'T GOT THE MONEY FOR THE
MORTGAGE ON THE COWS.

SON AND A BOO, A BOO, A BOO HOO HOO HOO,
DAUGHTER I SAID A BOO, A BOO, A BOO HOO HOO HOO.

MOM: A SOB, A SOB, A SOB SOB SOB,
I SAID A SOB, A SOB, A SOB SOB SOB.

COWS: A MOO, A MOO, A MOO MOO MOO,
I SAID, A MOO, A MOO, A MOO MOO MOO.

(VILLAIN ENTERS, DISPLAYS MORTGAGE PAPER)

VILLAIN: I CAME TO GET THE MONEY FOR THE MORTGAGE ON THE
COWS! I SAID I CAME TO GET THE MONEY FOR THE
MORTGAGE ON THE COWS!

(MOM MOVES BETWEEN COWS AND VILLAIN)

MOM: BUT I AIN'T GOT THE MONEY FOR THE MORTGAGE ON THE
COWS! I SAID I AIN'T FOR THE MONEY FOR THE MORT-
GAGE ON THE COWS!

COWS: A MOO, A MOO, A MOO MOO MOO,
I SAID A MOO, A MOO, A MOO MOO MOO

(VILLAIN EYES DAUGHTER, TWITCHES MOUSTACHE)

VILLAIN: I'LL TAKE YOUR PRETTY DAUGHTER FOR THE MORTGAGE ON
THE COWS! I SAID I'LL TAKE YOUR PRETTY DAUGHTER
FOR THE MORTGAGE ON THE COWS!

(DAUGHTER COWERS BEHIND MOM)

DAUGHTER: A NO, A NO, WITH YOU I'LL NEVER GO!
I SAID A NO, A NO. WITH YOU I'LL NEVER GO!

(VILLAIN ADVANCE MENACINGLY TOWARD HUDDLED MOM, SON, DAUGH-
TER, AND COWS)

VILLAIN: A HA, A HA, A HA HA HA!
I SAID A HA, A HA, A HA HA HA!

(MOM AND KIDS COWER TOGETHER)

MOM AND A SOB, A SOB, A SOB SOB SOB!
KIDS I SAID A SOB, A SOB, A SOB SOB SOB!

COWS: A MOO, A MOO, A MOO MOO MOO
I SAID A MOO, A MOO, A MOO MOO MOO

(HERO ENTERS WITH MONEY BAG AND BRIGHT SHINY TEETH)

HERO: I'VE GOT THE MONEY FOR THE MORTGAGE ON THE COWS!
I SAID, I'VE FOR THE MONEY FOR THE MORTGAGE ON THE
COWS!

HERO GIVES MONEY BAG TO MOM)

EVERYONE: A YEA, A YEA, A YEA YEA YEA!
(EXCEPT I SAID A YEA, A YEA, A YEA YEA YEA!
VILLAIN)

(VILLAIN CRINGES, TWEAKS MOUSTACHE)

VILLAIN: A CURSES, A CURSES, A CURSES CURSES CURSES!
I SAID, A CURSES, A CURSES, A CURSES CURSES
CURSES!

COWS: A MOO, A MOO, A MOO MOO MOO,
I SAID A MOO, A MOO, A MOO MOO MOO

(VILLAIN GRABS MONEY BAG AND WRAPS SLIMY ARM AROUND DAUGH-
TER)

VILLAIN: I'LL TAKE YOUR LOVELY DAUGHTER AND THE MORTGAGE ON
THE COWS! I SAID, I'LL TAKE YOUR LOVELY DAUGHTER AND
THE MORTGAGE ON THE COWS!

(HERO DRAWS PISTOL AND AIMS AT VILLAIN)

HERO: KABOOM, KABOOM, KABOOM BOOM BOOM!
I SAID KABOOM, KABOOM, KABOOM BOOM BOOM!

(VILLAIN, CLUTCHING BREAST - HIS OWN, FALLS TO FLOOR)

VILLAIN: OH ARGH, OH ARGH, OH ARGH ARGH ARGH!
I SAID OH ARGH, OH ARGH, OF ARGH ARGH ARGH!

(VILLAIN EXPIRES, DAUGHTER RUSHES TO HERO'S SIDE)

EVERYONE: A YEA, A YEA, A YEA YEA YEA!
I SAID A YEA, A YEA, A YEA YEA YEA!

(HERO BLOWS SMOKE FROM MUZZLE OF PISTOL)

HERO: A PHU, A PHU, A PHU PHU PHU
I SAID A PHU, A PHU, A PHU PHU PHU

COWS: A MOO, A MOO, A MOO MOO MOO!
I SAID A MOO, A MOO, A MOO MOO MOO!

(CURTAIN FALLS AS EVERYONE LIVES HAPPILY EVER AFTER)

GENERAL REQUIREMENTS FOR CUBS & WEBELOS

AREA IV

INTRODUCTION

The High Adventure Team is chartered with the responsibility to conduct training courses to provide an awareness of the various aspects of High Adventure activities. This awareness allows maximum participation within safe and acceptable limits. Knowledge can often insure success, completion and enjoyment and prevent tragedy and misery. In addition, to help promote the various High Adventure activities, an awards program was created to recognize various accomplishments. It is the intent of the various council's High Adventure Teams to standardize the General Requirements to avoid confusion. Specific requirements will henceforth be included with the specific awards, i.e. distances, hiking hours, conservation hours, conditioning requirements, etc.

1. CHANGES OR EXCEPTIONS

Changes, exceptions, modifications, or waivers of any High Adventure Award requirements shall be made only in advance of the outing and in writing by the High Adventure Team of the council sponsoring the award. They shall not be made by any other person, including professional scouts, council employees, or volunteer scouts.

2. AWARDS MUST BE EARNED

No High Adventure Award shall be given, or otherwise made available, to any person who has not completed all of the requirements for the award, including these General Requirements.

3. RECIPIENTS MUST BE REGISTERED

Only Currently registered members of the Boy Scouts of America are eligible to receive High Adventure Awards.

4. REGISTERED UNITS

Awards may be earned only on scheduled outings of registered units, or a District or Council function.

5. ONE TRIP/ONE AWARD

Generally, only one award may be earned for one outing, unless otherwise stated in writing in the award requirements. Cub Scouts and Webelos may only earn those awards specifically contained in this book, High Adventure Awards and Programs for Cubs and Webelos.

6. BSA TOUR PERMIT

A Local Tour Permit, BSA Form 4426, issued by the local Council, is required if the distance is less than 500 miles and the trip is within the North American Continent, including Canada and Mexico. A National Tour Permit, BSA Form 4419, issued by the Western Region, is required if the tour is 500 miles or over or if the tour is in a foreign country. Applications for both tour permits are to be submitted in advance in accordance with local Council procedures. A tour permit number is required with all award applications. Some Councils require additional permits which must also be obtained.

7. OTHER PERMITS REQUIRED

When/where other permits/requirements are necessary they must be obtained for the trip in order to be eligible for High Adventure Awards. These are "Wilderness", "Dispersed Area", "Use", "Primitive Area", "National Park", "Camping", "Fire", "State Park" permits. It is the intent that units meet and comply with the various Agency Requirements for a particular area.

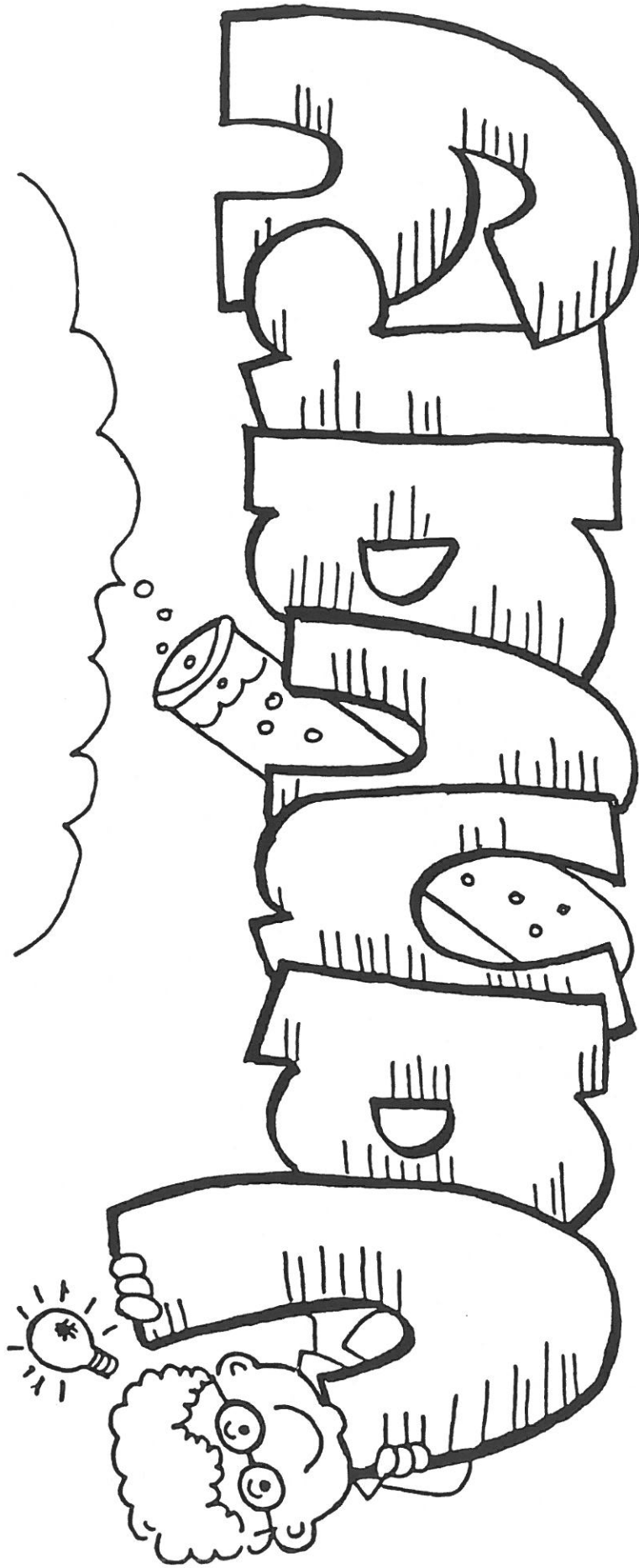

**Invention Convention
Handyman/Readyman**

JANUARY INVENTION CONVENTION HANDYMAN/READYMAN



SONGS BE A GENIUS

Tune: Are You Sleeping?

Be a genius, be a genius,
Do your best, Do your Best,
Give science your attention,
Or make a Cub invention,
Genius does the rest,
Genius does the rest.

DAD'S TOOLS

Tune: Three Blind Mice

I want to invent something.
I want to invent something.
It'll be grand.
It'll be grand.
If only I could use Dad's tools.
I can make it look real cool
Impress everyone at school
But he won't let me.
But he won't let me.

CUB SCOUT INVENTION

Tune: Down By the Station

For our Cub Scout meeting
We made a new invention.
We used all the junk
Our parent's threw away.

We hammered and we sawed
And glued it all together.
What a super job we did,
But what does it do?

INVENTING SOMETHING

Tune: Are You Sleeping?

Inventing something,
Inventing something,
Don't know what.
Don't know what.
Put it all together.
Put it all together.
Hope it works.
Hope it works.

HOW TO GET IDEAS

Tune: Row, Row, Row Your Boat

Use, use, use your brain,
Put your mind in gear,
Bright ideas aren't a strain
You have some never fear.

Think, think so hard
Service you can give,
Help some other people and
Your life's more fun to live.

Do, do, do your best
Do a good deed now
It will make you happy and
Cub Scouting shows you how.

Readyman:

List emergency numbers for your
area. Print and distribute to
the neighborhood.

Visit paramedics.
Learn basic first aid.

Learn about Emergency Preparedness.

Check household Emergency supplies.

PAGE 2 JANUARY - INVENTION CONVENTION HANDYMAN/ READYMAN

PERSONAL FIRST AID KIT

Use a 35mm film canister. Put in it:
 2" square of moleskin
 2 one-inch adhesive bandages
 A quarter for phone call
 2 premoistened towelettes or
 one small hotel-size bar of soap
 2 acetaminophen (aspirin substitute)
 tablets in foil
 1 first aid leaflet
 2 wood matches (cut to fit)
 match striker material from box or
 book of matches

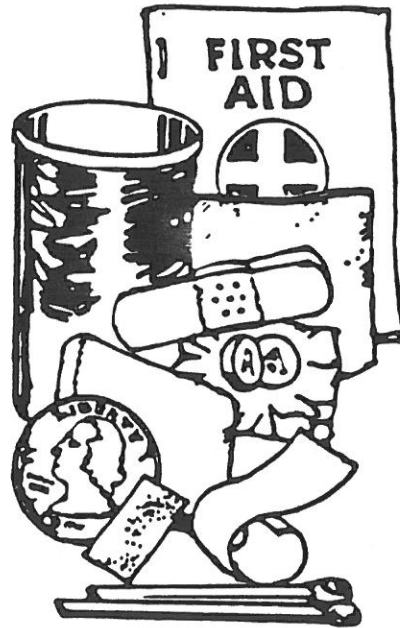

Fire bucket neckerchief slide

need 35mm film can painted red

3 cotton balls	pipe cleaner
plaster & water	strip of adhesive
small amount of sand	tape marked 'in case of fire'

1. tape paper or adhesive tape sign to front of painted can.
2. punch two holes in back of can, near top about one inch apart.
3. insert pipe cleaner, bending ends flat against inside of can
4. stuff can with 3 cotton balls
5. mix plaster with water to consistency of sour cream. Work quickly or it will harden too fast.
6. while plaster is still wet sprinkle top with sand, shake off excess.

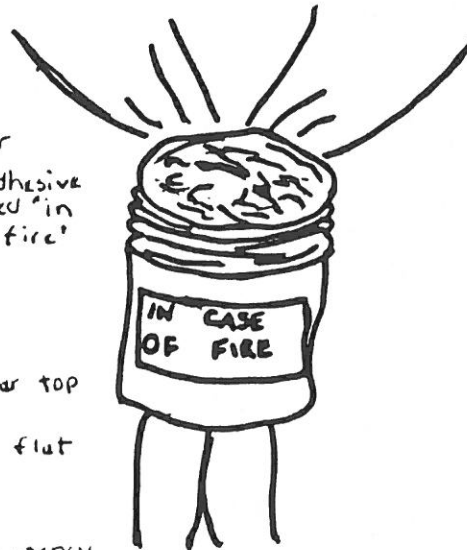

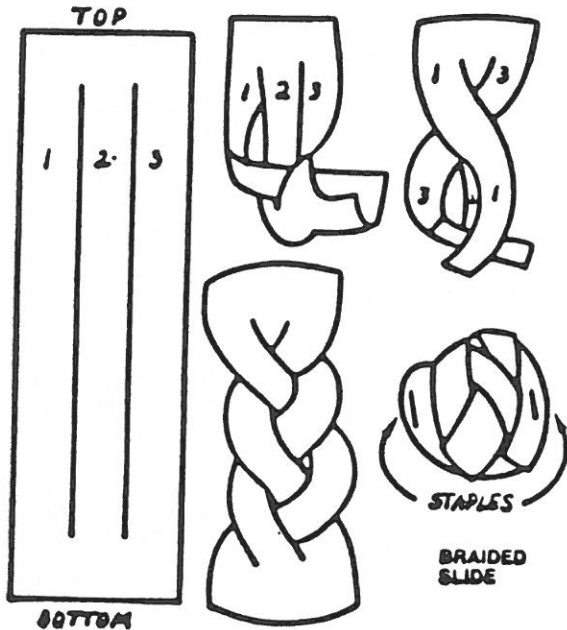

BRAIDED SLIDE

This novel slide is easier to make than you think.

1. Cut soft leather or cloth-backed vinyl to 1 1/4 by 4 1/2 inches. Cut two slits, dividing the length into thirds, as illustrated. Number the thirds 1, 2, and 3, from left to right (Fig. A).
2. Take bottom left corner and push it through slit between 2 and 3 (Fig. B).
3. Put strip 3 on top of strip 2. Then put strip 1 on top of strip 3, making a sandwich with strip 3 in the middle. With fingers, work strip 3 out to left, exposing an open loop (Fig. C).
4. Take bottom end, bring it toward you, then insert it through loop and pull it through.
5. Rework with fingers into a braided strip which looks like Fig. D.
6. Use a small stapler to staple top and bottom ends together (Fig. E).
7. Slide may be made larger by lengthening the pattern.

Abacus

BY TELL AND DON GUBLER

Wood, beads and toothpicks add up to a smart-looking slide.



IN THESE DAYS of electronic calculators, this slide brings to mind the old hand-powered calculator called an abacus.

All you need are a few wood scraps, round toothpicks, a popsicle stick and beads (if you find the beads first, you can adjust the size of the frame to fit them).

Using a coping saw, cut the frame from crate slats or other 1/2-inch wood. Cut to length first, then carefully miter (slant) the corners so they fit together well. For the divider use a popsicle stick cut to the proper dimensions.

Next sand down the toothpicks so they will fit through the holes in the beads. If the holes are too small, widen them with a sharp pointed knife. Be careful not to split the beads or cut your fingers.

If the beads are plastic, you can heat a small nail over a candle flame and poke the nail through the bead (use pliers to hold the bead and another pair to hold the nail).

You may want to paint the beads so that each row is a different color. Model enamel will work best on most beads.

Once you've fitted the beads on the toothpicks, and before you trim the toothpicks, drill holes in the side frames and in the middle divider.

Be careful to line the holes up horizontally. They should be close enough to the edge of the frame pieces so that the sides of the beads are just above the rim of the frame but far enough in to hold the toothpicks securely.

Insert the toothpicks in the divider and glue them in place.

When the glue has dried, slip on the beads. Now fit on the frame, trimming the toothpicks just enough for the frame to be perfectly square. Glue the frame together and to the toothpicks.

Cut the loop from a scrap of wood and glue it to the side frames. Sand the frame with fine sandpaper, then apply a light coat of shellac or varnish.

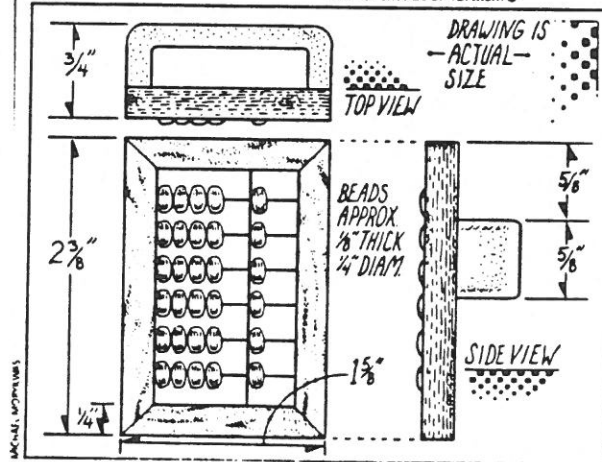

PAGE 4 JANUARY - INVENTION CONVENTION HANDYMAN/READYMAN



Leather Craft

Leather, one of the basic crafts materials, has much to offer Cub Scouts, including learning new skills in creating useful and beautiful items.

Leather can be decorated by painting designs on it, dyeing it, tooling it, stamping patterns in it with punches, burning designs on it, or by weaving or braiding through it. Don't confine your work to simply lacing together pre-cut bits. Tooling, embossing, and stamping are skills that can be learned by Cub Scout-age boys.

Leather can be expensive. Look for stores that will give away leather scraps or sell bags of scraps at a low price. Scrap leather is suitable for most Cub Scout leatherwork projects. Heavy scrap vinyl, such as upholstery vinyl, can be used as a substitute for leather in some projects.

Begin with leather tooling, one of the simplest types of leathercraft. This skill requires only one tool, a modeler or stylus, and a project can be completed in a short time.

LEATHER TOOLS

Although there are carving tools for many types of designs in leatherwork, Cub Scouts will need only a few, and they can be homemade. Make the modeling tools from hardwood dowels of different diameters and shapes, or check with your local Scout distributor or leather store.

Background Tools

These can be dowels shaped into dots or nails filed into any designs, such as flowers, stars, squares, circles, single lines, double lines, and cross-hatched lines. Use the edges of a square-headed nail to form lines into squares and triangles.

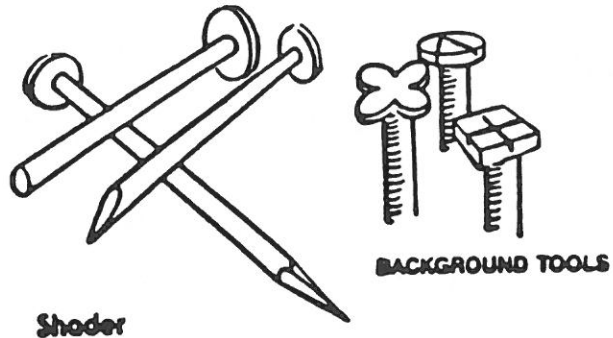

Shader

Use this tool when depressed areas are needed. The angle at which you hold the tool determines the size and depth of the depression. Hold shader in left hand and strike it with a good firm blow of your striking stick.



Bevelers

Make these in two sizes. Use the large one for all long cuts and the small one on all sharp turns. To get a raised effect, depress the leather on the outside of the design, except on curves. Place the beveler on the cut lines and hold it in an upright position. Give the beveler light taps with a wooden mallet or striking stick as you move it forward with each stroke.

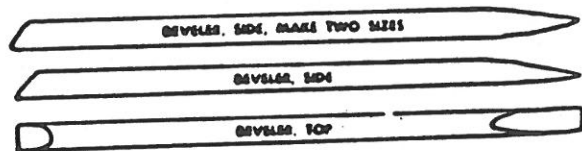

BEVELERS

Veiners

Make flowers, leaves, and ornamental designs with these tools. Hold the veiner in an upright position. Start at the base and work toward the point of the leaf. Lean veiner to the right or left depending on the design.

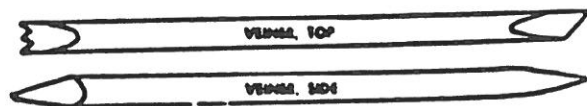

VEINERS

PAGE 5 JANUARY - INVENTION CONVENTION HANDYMAN/ READYMAN

Punch, Awl, Scriber

These tools can be made from spikes filed to desired point.

In addition to these tools, the following will be helpful:

Wooden Mallet. For striking stamping tools.

Leather Punch. Similar to a paper hole punch, to punch holes in leather for lacing, or punching belt holes.

TIPS FOR WORKING LEATHER

- Use a hard surface as a base when tooling leather. Marble is an excellent base since it doesn't absorb moisture. You can also use laminated counter-top scraps (from counter-top manufacturers and kitchen remodeling firms).
- Dampen all leather completely before working on it. Redampen from back side if it dries out before you are finished.

NOTE: Do not moisten leather which will have a burned design. Use regular wood-burning set.

LEATHER TOOLING

1. With a sponge or cloth, dampen the leather on the dough side with cold water. After a short while the dampness will reach the finished side of the leather. If it looks wet on the finished side, it is too damp to tool. Wait until it dries slightly and the natural leather color returns.



2. Place pattern on front side of dampened leather. Fasten it in place with tape or a clamp. Trace the pattern with a stylus. Lift one end of the pattern to be sure all of the pattern has been transferred. Remove pattern.
3. Lay leather on a firm surface. Use the slanted end of the modeler or stylus to level around all the outside lines and around the inside of any other lines. Always draw the tool toward you. Keep an even pressure on the stylus to prevent making deep marks in the leather. This technique brings out a darker, waxed-like color in the leather, and the depression will produce an attractive design. If the design is not clear enough, go over it again. Redampen the leather if necessary.
4. When design is finished and leather is dry, apply final finish. Use wax, saddle soap, or leather dressing.

LEATHER STAMPING

1. Dampen leather on back side. Do not soak.
2. Place leather on hard surface.
3. Hold stamping tool in one hand and tap gently with a wooden mallet.
4. Strike tool carefully to prevent cutting through leather.

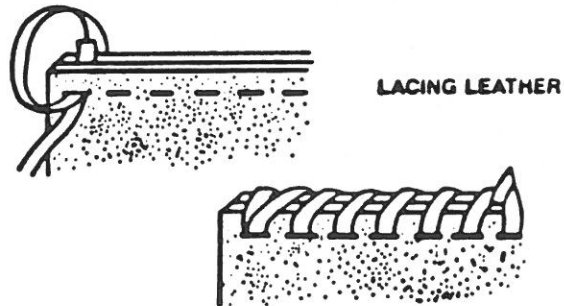

LACING LEATHER

Leather or plastic lacing can be obtained at your local Scout distributor or at a craft or hobby store.

The spiral or whipstitch, illustrated here, is the simplest lacing stitch. It consists of running a single lace, spiral fashion through successive holes. Always make the first and last lace a double one, to conceal the ends.

NOTE: If leather becomes soiled while working with it, it can be cleaned with saddle soap. Apply with an old sock to entire surface and allow to dry. Do this before applying wax.



Mardi Gras
Scholar/Engineer

FEBRUARY MARDI GRAS SCHOLAR/ ENGINEER

SONGS

MARDI GRAS

**Tune: Johnny Comes
Marching Home**

**It's carnival time in New
Orleans,
Hurrah, Hurrah
We'll stay up all night til
mornings light,
Hurrah, Hurrah
Let's blow the whistle and
bang the drum,
No sleep tonight for anyone
At the Mardi Gras
The Mardi Gras parade.**

THE MARDI GRAS SHOW

Tune: Animal Fair

**Oh come see the Mardi Gras
Show,
And see the parade you
know
There's lots of fun for
everyone,
With costumes beyond
compare.
There are thrilling scenes and
dance,
And floats that will entrance,
Food to eat that can't be
beat,
Oh come to Mardi Gras
show-the show the show.**

CUB SCOUT MARDI GRAS Tune: Take me out to the Ball Game

**Let's all go to the MardiGras,
Let's all join in the fun!
Singing and laughter and lots
of joys,
Join the Parade with all of
the boys,
So, come let's all go together,
Make Mardi Gras really
great.
For it's Wolves, Bears,
Webelos Scouts,
It will be first rate.**

MARDI GRAS FOR CUB SCOUTING

**Tune: When Johnny Comes
Marching Home Again**

**The Cub Scouts Mardi Gras
begins,
Hurrah, Hurrah
We'll have parades and songs
to sing, Hurrah, Hurrah.
With big brass bands and
clowns around, We'll sing
and shout-make lots of
sounds, And we'll all be there
When Mardi Gras comes to
town.
We'll need a costume bright
and new
Hurrah, Hurrah.
One for me and one for you,
Hurrah, Hurrah.**

PAGE 2 FEBRUARY - MARDI GRAS
SCHOLAR/ENGINEER

We'll march and sing and
prance and shout,
With music, music all about
And we'll all be there,
When the Mardi Gras comes
to town.

MARDI GRAS
Tune: Deep and Wide

Mardi Gras, Mardi Gras
We'll have fun this month a
Mardi Gras Mardi Gras,
Mardi Gras We'll have fun
this month At Mardi Gras

LEATHER OR VINYL SLIDES

Scraps of leather or vinyl in color to suit your "theme"

Permanent markers

Wiggly eyes or buttons for faces

Pipcleaners or vinyl strips for the back of the slide

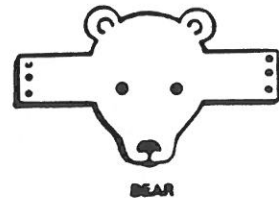

BEAR



PUMPKIN



BOBCAT PIN

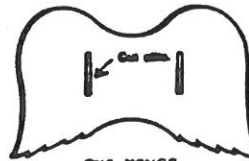

OWL WINGS

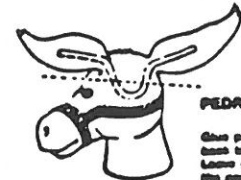

PEDRO (BACKVIEW)

Glue pipe cleaner on back to make ears. Leave a loop for the necktie.

WOLF RANK SLIDE. Cut from 1/4-inch wood with jigsaw or coping saw. Glue on loop of wood or leather.

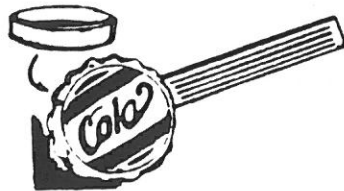

BANJO SLIDE. Boys working on the Bear Cub Scout Band elective may want to wear this. For the box, use a bottle cap. Glue on a popsicle stick which has been cut square at one end. Use fine marker to make strings. Glue on ring of leather or cardboard.

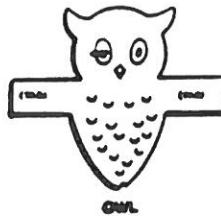

OWL

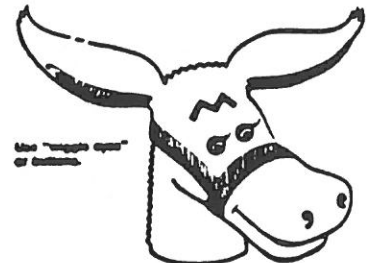

BOYS' LIFE PEDRO

Use "wiggly eyes" or buttons.

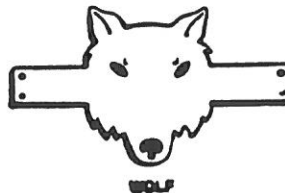

WOLF

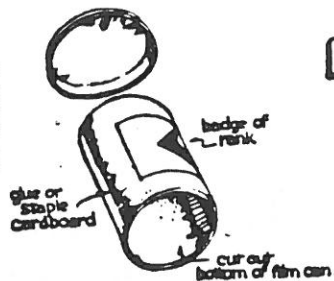

DECAL SLIDE. Cut bottom from a 35mm film canister or use 2-inch section of paper-towel core. For the emblem, use badge of rank from small Cub Scout Insignia Stickers Sheet, No. 4649.

glue or staple cardboard

badge of rank

cut out bottom of film can.

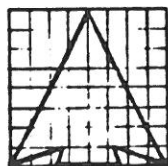

ARROW POINT SLIDE. Use grid to enlarge arrow point to 2x3 inches. Draw on soft wood and whittle. Paint gold or silver. Glue on ring of leather or cardboard.

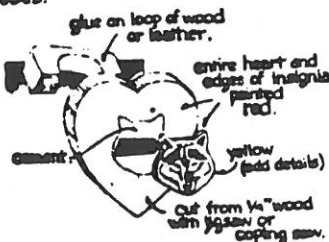

glue on loop of wood or leather.

entire heart and edges of insignia painted red.

yellow (add details)

glue on

cut from 1/4" wood with jigsaw or coping saw.

PAGE 3 FEBRUARY - MARDI GRAS
SCHOLAR/ ENGINEER

PAPER DOLL VALENTINE

MATERIALS

White sheet of paper
Pencil
Crayons or markers
Construction paper

DIRECTIONS

1. Accordion-pleat a long piece of white paper into folds about an inch across.
2. With a pencil, lightly sketch half of a paper doll, being sure that the center is on a fold and that the hands come right out to the end of the paper so the dolls will be holding hands.
3. Cut the dolls out while the paper is still folded.
4. On the chest of each doll write a letter, for instance L-O-V-E.
5. If you use construction paper the dolls will stand up. Leave them partially folded and curve the end dolls toward each other.
6. If you cut the dolls out of white paper you can paste them on a large piece of construction paper and print a message to your valentine.

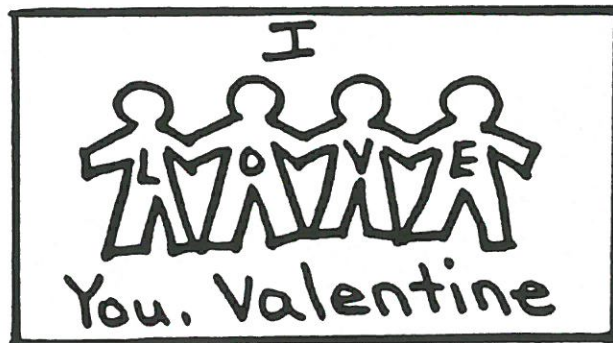

PAGE 4 - FEBRUARY - MARDI GRAS SCHOLAR/ENGINEER

VALENTINE RING



MATERIALS
Paper plates
Construction Paper
Scissors
Glue
Red Yarn

DIRECTIONS

1. Cut the centers from two paper plates.
2. From red construction paper, cut a heart that will fit in the center of the plates. Cut out the letters L-O-V-E and glue into the center of the heart.
3. Attach a long piece of red yarn to and heart, and glue the two plates rim to rim with the yarn between them, as shown in the picture.
4. The extra string will act as the hanger.
5. Decorate the valentine ring with cut paper and markers.
6. Hang it on your favorite person's doorknob.



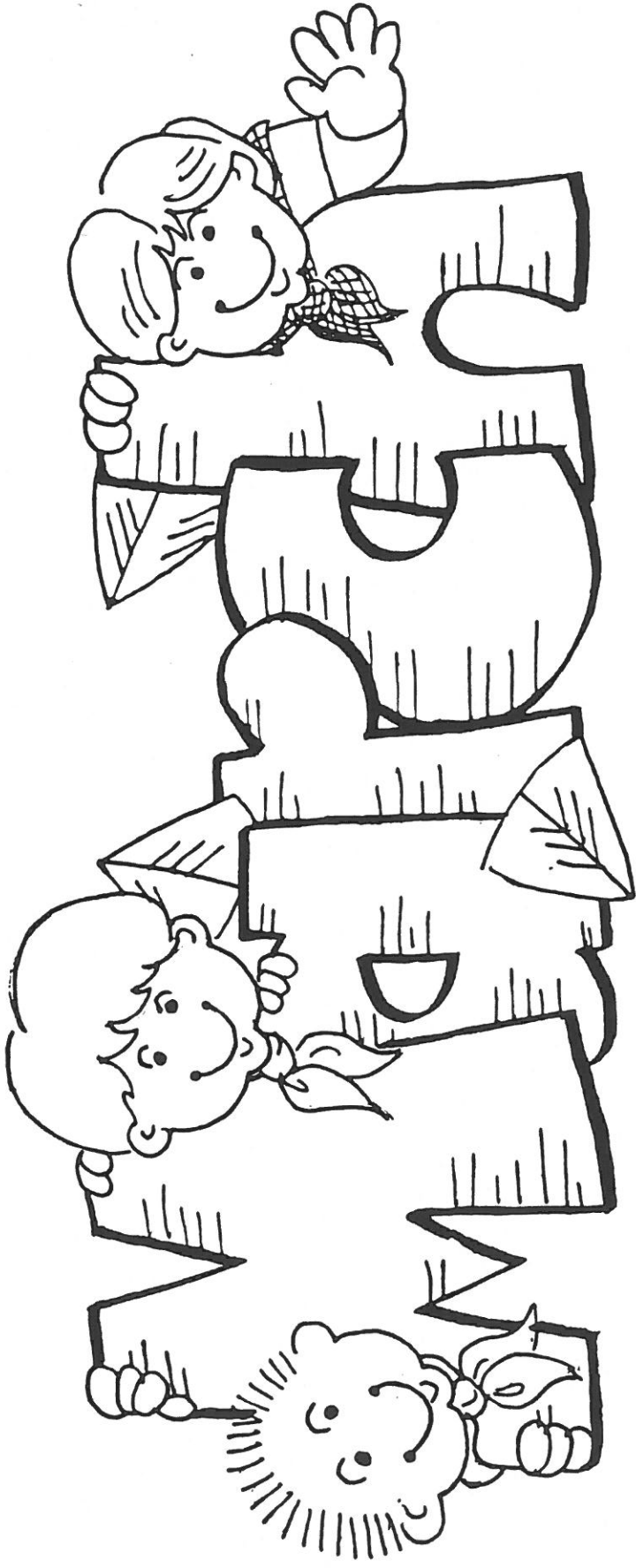

**Achievement Parade
Naturalist/Engineer**

**MARCH
ACHIEVEMENT PARADE
NATURALIST/ ENGINEER**

Game boards

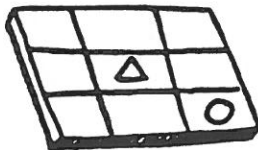

SONG

CUBS ALL ADVANCE
Tune: Camptown Races

Good Cub Scouts, they all
advance,
Doo-dah, doo-dah!
Every time they have a
chance.
Oh, doo-dah day!
Chorus(Repeat after each
verse)

Goin' to earn a badge,
Goin' to try today.
Advancing Cub Scouts have
more fun,
Oh Doo-dah day!

Bobcats, go to Wolf Cub
Scouts,
Doo-dah, doo-dah!
When their parents help
them out,
Oh Doo-dah day!

Wolf Cub Scouts go up to
Bear,
Doo-dah, doo-dah!
When it's time to move them
there,
Oh, doo-dah day!

Bears go on to Webelos,
Doo-dah, doo-dah!
When you work hard it
surely shows,

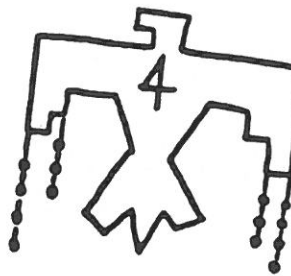

Den doodles

Oh, dooh-dah day!

The Arrow of Light is next
in Line
Doo-dah, doo-dah!
This Cub Scout's done might
fine,
Oh, doo-dah day!

Graduate him to a Boy Scout,
Doo-dah, doo-dah!
And his leader helps him out,
Oh, doo-dah day!

AKELA'S PACK

Tune: I've been Working on
the Railroad

We're a pack of happy Cub
Scouts
Webelos is our tribe.
We are waiting to be Boy
Scouts
When we become of age.
Don't you want to come and
join us-
Join our happy pack?
Don't you want to be a Boy
Scout?
Come, and "Do Your Best".

ADVANCE IN RANK

Tune: When the Saints go
Marching In

Oh when the Cubs come

**PAGE 2 - MARCH - ACHIEVEMENT PARADE
NATURALIST/ ENGINEER**



marching in,
Oh, when the Cubs come
marching in,
I want to be in that number,
When the Cubs come
marching in.
And when the pack gives out
awards,
And when the pack gives out
awards,
Oh, I want to be in the
number,
When the pack gives out
awards.
There's Bobcat first, and then
there's Wolf.
And next there's Bear and
Webelos,
Oh, I want to earn those
badges,
More than anybody knows.

So I'll work hard, to earn my
ranks,
And climb the ladder step by
step,
And I'll always do my best,
That's a promise that I've
kept.

**THAT'S WHY WE'RE IN
CUB SCOUTING**
Tune: Deep in the Heart of
Texas

The fun things in life
Our family's delight
(Clap 4 times)
That's why we're in Cub
Scouting.

We do our best
To pass each test
(Clap 4 times)
That's why we're in Cub
Scouting

Just me and my son,
Work, play and have fun
(Clap 4 times)
That's why we're in Cub
Scouting

EIGHT CUB SCOUTS
Tune: 3 Blind Mice

Eight Cub Scouts, Eight Cub
Scouts,
See how they go. See how
they go.
They all went after the
Bobcat pin,
The Wolf and the Bear were
the next to win,
And then they went on to the
Webelos Den.
Eight Cub Scouts, Eight Cub
Scouts.

**I'D LIKE TO TEACH THE
WORLD TO SING**

I'd like to teach the world to

**PAGE 3 - MARCH - ACHIEVEMENT PARADE
NATURALIST/ENGINEER**

sing in Cub Scout harmony.
The blue and gold will be the
thing
For everyone to see.

Each Wolf and Bear and
Webelos is doing all he can.
To do his best with all the
rest
Of Cub Scouts in the land.

We're the real thing
(Cub Scouts)
Come join us and see
(Cub Scouts)
What fun really can be
(Cub Scouts)
We're the Cub Scouts

**KEEP ADVANCING
Tune: Clementine**

We're the Bobcats, Wolf and
Bear Cubs;
And true Webelos are we
Altogether we're a Cub Pack,
That's well known from sea
to sea.
Keep advancing,
keep advancing.
Step by step, right up the
line.
If you want to be a Boy
Scout,
Never, ever, lag behind.

ST PATRICK'S DAY CROWN

MATERIALS
Green Construction paper
Green Pipe Cleaners
Black Marker
Glue
Green Yarn

- DIRECTIONS**
1. Cut a band of paper long enough to fit around your head.
 2. Glue green pipe cleaners into the band.
 3. Cut an archway from green construction paper and glue to the top of the pipe cleaners.
 4. Glue green yarn to the band.
 5. On the band write "St. Patrick's Day" with a marker.
 6. Glue the ends of the band together to form the crown.



braided neckerchief slide

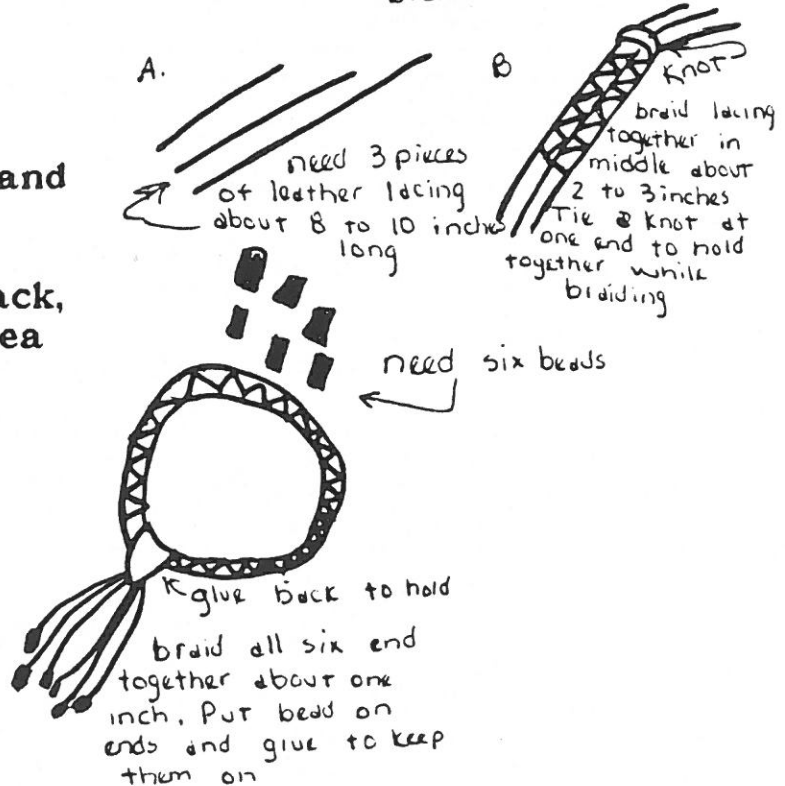

PAGE 4 - MARCH - ACHIEVEMENT PARADE NATURALIST/ENGINEER

Cub/Webelos Awards for Old Baldy

AKELA AWARD

The Akela Award is a Cub Adventure program to assist Webelos in becoming Boy Scouts. It is an optional program for each boy and is not required for any rank. It is to be used at the discretion of the Unit Leaders to help a boy transition successfully from Cub Scouts to Boy Scouts. Cubmasters, Scoutmasters, and Den Chiefs may earn this award.

» Requirements:

1. As a Webelos Scout, earn three Activity Badges in addition to those earned for the Arrow of Light. (A total of ten Activity Badges.)
2. As a Webelos Scout, attend one Boy Scout Troop Court of Honor.
3. As a Webelos Scout, do two hours of cumulative service in the home. Parents and boy must agree on the project before it is started. Service projects cannot be applied to any other awards or recognition, nor can any project be applied to the Akela Award when used for other awards or recognitions. The Webelos Leader must approve all service projects.
4. As a Boy Scout, be active in your Troop and Patrol for six months.
5. As a Boy Scout, within six months from time of registration, attend at least one overnight campout as a member of your Troop.
6. As a Boy Scout, earn the Scout Badge.
7. As a Cubmaster, Webelos Den Leader, Scoutmaster, or Den Chief, have a minimum of four boys in your Pack, Den, or Troop earn the Akela Award.

» Implementation:

The implementation of the Akela Award should be made as simple as possible to avoid conflicts and misunderstandings regarding how the award is earned.

This award is retroactive to January 1, 1987.

» As a Webelos Scout:

1. Each boy receives an advancement card after he earns his Webelos Badge. All signing is done by appropriate leaders on the card.
2. As a Webelos Scout, requirements 1 & 2 are signed by the Webelos Leader.
3. The Webelos Leader certifies the Webelos Scout has completed all the requirements for the Webelos part of the Akela Award. This is done on the advancement card.
4. The Webelos Scout maintains possession of the advancement card at all times. Upon completion of a requirement, he submits the card for signing.
5. The Webelos Leader develops a program to assist the Webelos Scout in earning the award. The program may be developed on a Pack or Den basis.

6. At all times, it must be understood that the Akela Award is a voluntary award in the Cub Adventure Program and is not required for any other Scouting Award or advancement. It is strictly a supplement for your program.

» As a Boy Scout:

1. When a Webelos Scout joins a Scout Troop, he brings his Akela Advancement Card with him to the Troop.
2. The Akela Award Requirements for a Boy Scout are designed to be a natural part of Boy Scouting. The requirements are not designated to be activities over and above the regular Scouting Programs. Upon completion, all requirements are certified by the Scoutmaster.
3. The Scoutmaster and Troop officials should, at all times, offer directions and encouragement in earning the Akela Award since there is a six month time limit while the boy is a Scout.
4. At all times, it must be remembered and understood that the Akela Award is optional and not required for any advancement or award. The Boy Scouting part of the requirements are almost automatic and should create no real problem for implementation.

» General Implementations:

1. Once the advancement card has been completed, the certification part of the card is turned into the local H.A.T. representative. Upon receipt of the certification, the troop is authorized to purchase the award.
2. The presentation of the award should be made at the boy's Cub Pack Meeting by the Cubmaster and Scoutmaster of the units to encourage future Cub Scout participation. It is NOT recommended that the award be presented at a Troop Court of Honor.
3. The Akela Award can only be worn centered on the right pocket of the Boy Scout Uniform.



Fig. 3 - 1
AKELA AWARD
3" DIA.

PAGE 5 - MARCH - ACHIEVEMENT PARADE NATURALIST/ENGINEER

PLASTER CASTING AND MOLD MAKING

WHAT TO COPY

1. Use an existing plaster piece
2. Magnets, toys
3. Candy molds, playdough molds
4. Plaster molds from craft stores
5. Designs from soap or wood
6. Bread dough ornaments
7. Cookie molds i.e. Hallmark

HOW TO MAKE A RUBBER MOLD

1. Make sure item to copy is sealed, acrylic statuary spray, varathane, if wood. Cover meat tray, cardboard with aluminum foil, plastic wrap before starting. Dab a little of the mold-it on the foil or plastic wrap then stick on piece to be copied. This will keep it from slipping.

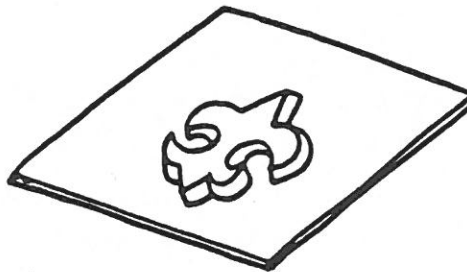

2. Apply a thin coat of mold-it (use plastic spoon, popsicle stick). This layer will copy the detail off your piece, pop all bubbles with a pin. Allow to dry. Mold-it is almost white when wet and gets darker as it dries.



3. Apply a heavier coat of mold-it. Be sure to add a rim of mold-it around the piece. Allow to dry.
4. Dab on a third coat and make sure you again add to the rim. Do step 5 before allowing to dry.
5. To add strength and durability
 - a) apply one layer of cheesecloth or bandage gauze
 - b) add thin coat of mold-it
6. Wait until the mold-it is thoroughly dry before removing the original piece.

HOW TO PREPARE THE MOLD

1. Make sure candy mold, liquid rubber (mold-it) mold is clean of residue.
2. When using cookie cutters (solid) spray a gentle mist of Pam. Use original formula. Too much will pit your copy.

PAGE 6 - MARCH - ACHIEVEMENT PARADE NATURALIST/ENGINEER

MIXING PLASTER

1. Fill mold with water (this is how to measure amount of water needed per mold).
Pour water into disposable container, (paper cup, aluminum pan, oleo tub).

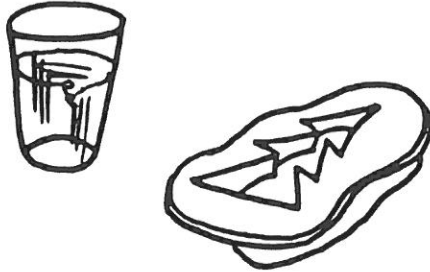

2. Add small amount of plaster at a time until it stops dissolving and a small peak is showing above the water level.



3. Stir gently to avoid air bubbles. The mixture should resemble heavy cream.
4. Do not mix more plaster than will be used, for it hardens quickly and cannot be thinned.

TYPES OF PLASTER

Plaster of Paris (casting plaster)
Dental Plaster (Best quality but expensive)
Hydrocal (lighter, inexpensive, but hard to find)

Plaques and awards

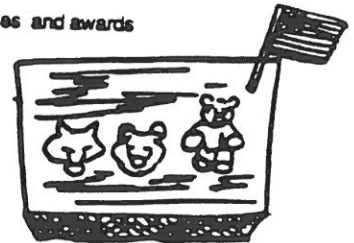

POURING THE PLASTER

1. Pour plaster into mold
2. Tap mold so that air bubbles will rise to the surface. Pop air bubbles with a tooth pick or pin
3. Allow mixture to stand until hard. Plaster will become warm to the touch, after it cools it's ready to remove. If a large amount of water is on top wait until water has evaporated. The piece is not ready. Time factor should be 15 to 20 minutes depending on weather conditions and amount of plaster poured.
4. Rough edges on plaster piece can be sanded after piece is removed from mold. Ceramic shops have tools for this purpose.

PAGE 7 - MARCH - ACHIEVEMENT PARADE NATURALIST/ENGINEER

HOW TO ADD HANGERS AND RINGS

For tie slide: bent wire
 large wire staple
 PVC plastic pipe (cut into rings)
 pop top ring
 paper clip
 chinese jacks



Place in mold after pouring plaster, or hot glue to finished slide

Magnet: Hot glue magnetic strip or button after plaster has dried or place on piece after plaster has become tacky.

Medalion: Place ribbon, yarn, string, rope or cord in mold right after pouring plaster.

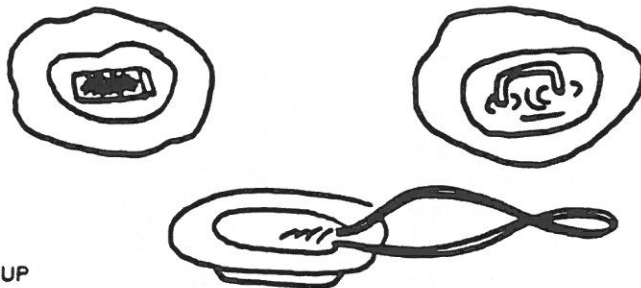

CLEAN UP

NEVER wash plaster down the drain. Dump dried plaster in trash can.

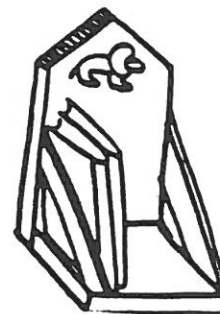

Book cases

HOW TO PAINT PLASTER

Plaster is porous so the paint you use is very important. When using acrylic paints or oils the plaster piece does not have to be sealed. If you are going to use poster paints or water colors, they will soak in and become dull. Use gesso, Mod podge, or latex wall paint to seal the plaster. When finished painting and piece is dry then spray with a clear plastic statury spray, this gives the plaster a real luster.

WHAT ELSE TO DO WITH PLASTER

Now that you have mastered the mold making process, expand your expertise.

Copy holiday motifs and apply to wood, jar tops

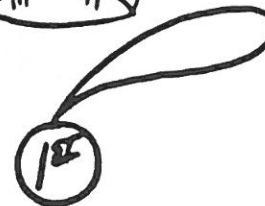
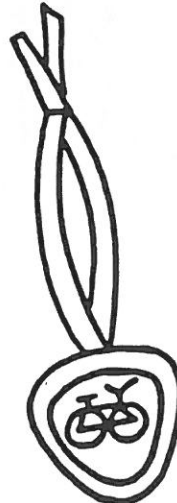

Medalions
for Cub Scout activities

DEN DOODLES ♦

BY STACY H. WOOD... SIWANoy COUNCIL
FIELD COMMISSIONER... WESTCHESTER CO., N.Y.

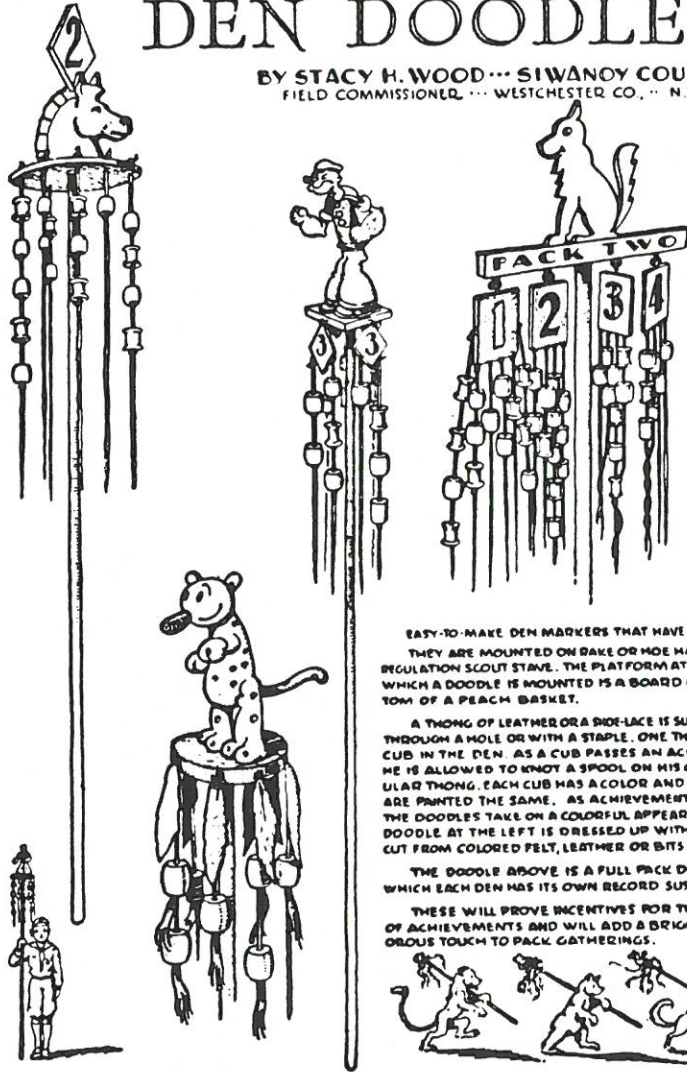

EASY-TO-MAKE DEN MARKERS THAT HAVE A PURPOSE.
THEY ARE MOUNTED ON BAKE OR MOE HANDLES OR THE
REGULATION SCOUT STAVE. THE PLATFORM AT THE TOP ON
WHICH A DOODLE IS MOUNTED IS A BOARD OR THE BOT-
TOM OF A PEACH BASKET.

A THONG OF LEATHER OR A RICE-LACE IS SUSPENDED
THROUGH A HOLE OR WITH A STAPLE. ONE THONG FOR EACH
CUB IN THE DEN. AS A CUB PASSES AN ACHIEVEMENT
HE IS ALLOWED TO KNOT A SPOOL ON HIS OWN PARTIK-
ULAR THONG. EACH CUB HAS A COLOR AND ALL HIS SPOOLS
ARE PRINTED THE SAME. AS ACHIEVEMENTS ARE PASSED
THE DOODLES TAKE ON A COLORFUL APPEARANCE. THE
DOODLE AT THE LEFT IS DRESSED UP WITH STREAMERS
CUT FROM COLORED FELT, LEATHER OR BITS OF CLOTH.

THE DOODLE ABOVE IS A FULL PACK DOODLE FROM
WHICH EACH DEN HAS ITS OWN RECORD SUSPENDED.

THESE WILL PROVE INCENTIVES FOR THE PASSING
OF ACHIEVEMENTS AND WILL ADD A BRIGHT AND HUM-
OROUS TOUCH TO PACK GATHERINGS.



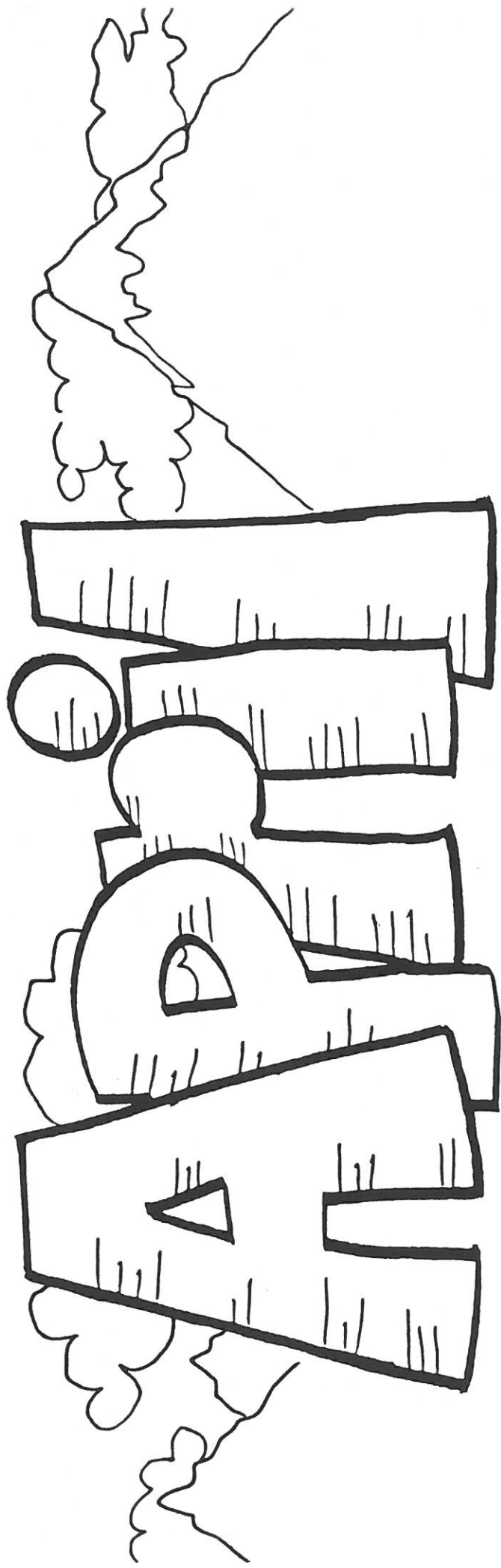

**Mountains of America
Geologist/Family Member**

**APRIL
MOUNTAINS OF AMERICA
GEOLOGIST/ FAMILY MEMBER**



**SONG
DOUGLAS MOUNTAIN
Tune: Clemetine**

Snows are falling on Douglas
Mountain
Snows are a-falling so deep,
Snows are a-falling on
Douglas Mountain.
Puttin the bears to sleep.

Trimin' the wicks on Douglas
Mountain,
Shinin' my chimney so bright,
Trimin' the wicks on Douglas
Mountain,
So God can bring the night.

**SHE'LL BE COMING AROUND
THE MOUNTAIN**

1. She'll be comin' 'round
the mountain when she
comes,
Toot, Toot!(Motion for pulling
whistle cord)
She'll be comin' 'round the
mountain when she comes,
Toot, Toot!(Same motion)
She'll be comin' 'round the
mountain
She'll be comin' ;round the
mountain
She'll be comin' 'round the
mountain when she comes,
Toot. Toot!(Same motion)

2. She'll be drivin' six
white horses when she comes,
Whoa back! (Pull back reins)

3. And We'll all go down
to meet her when she comes,
Hi, Babe.(Wave Hand)

4. And We'll kill the old red
rooster when she comes.
Hack, hack. (Chop wrist with
side of hand)

5. And We'll all have
chicken 'n' dumplings when
she comes, Yum, Yum!(Rub
Tummy)

6. And She'll have to sleep
with grandma when she
comes, Snore, snore(Make
snoring noises)

7. And she'll wear her pink
pajamas when she comes
(Wolf whistle)

8. And we'll wear our
bright red woollies when she
comes Scratch, scratch
(Scratch self)

**DIRECTIONS: AT THE END
OF EACH VERSE, REPEAT
IN REVERSE ORDER THE
SOUNDS AND MOTIONS OF
THE PRECEDING VERSES.**

**PAGE 2 - APRIL - MOUNTAINS OF AMERICA
GEOLOGIST/FAMILY MEMBER**

I LOVE THE MOUNTAINS

I love the mountains.
I love the rolling hills,
I love the flowers
I love the daffodils,
I love the campfires
When all the lights are
burning low
Boom-de-ada, Boom-de-ada,
Boom-de-ada, Boom-de-ada,
(etc)

DEN LEADERS HYMN

Tune: On Top of Old Smokey

On top of Old Smokey, all
covered with snow, I learned
a great lesson all people
should know. I met a Den
Leader, a helper of youth, He
was roaming God's mountain,
in search of the truth. He
told me he found it in the red
sunset's glow, In the voice of
the thunder, in the touch of
the snow. In the voice of the
thunder, in the touch of the
snow, His truth was quite
simple, as plain as could be,
I'll never forget what that
leader told me. Do your duty
to God, to the red, white, and
blue; To all others be helpful,
to thine ownself be true.

SMOKEY THE BEAR

With a Ranger's hat and
shovel and a pair of
dungarees You will find him
in the forest always sniffin'
at the breeze. People stop and
pay attention when he tells
'em to beware "Cause
everybody knows that he's
the Fire Preventing Bear.

CHORUS Smokey the Bear,
Smokey the Bear, Prowlin
and a growlin' and a sniffen
the air. He can find a fire
before it starts to flame,
That's why they call him
Smokey, that's how he got
his name.

You can take a tip from
Smokey that there's nothin'
like a tree, Cause they're
good for kids to climb in and
they're beautiful to see, You
just have to look around you
and you'll find it not a joke,
To see what you'd be missing
if they all went up in smoke.

CHORUS

You can camp upon his
doorstep and he'll make you
feel at home, You can run
and hunt and ramble
anywhere you care to roam.

**PAGE 3 - APRIL - MOUNTAINS OF AMERICA
GEOLOGIST/FAMILY MEMBER**

He will let you take his
honey and pretend he's not so
smart, But don't you harm
his trees for he's a Ranger in
his heart.

CHORUS

If you've ever see the forest
when a fire is running wild,
And you love the things
within it like a mother loves
he child. The you know
why Smokey tells you when
he sees you passing
through, Remember...please be
careful...its the least that you
can do.

CHORUS

THE HAPPY WANDERER

I love to go a wandering
along the mountain track,
And as I go I love to sing a
knapsack on my back.

CHORUS

Valderi, valdera, valderi
Val-de-ra-ha-ha-ha-ha-ha-ha-
ha Valderi, valdera, valderi
My knapsack on my back.

I love to wander by the
stream, that dances in the
sun, So joyously it calls to

me, "Come join my happy
song"

CHORUS

I wave my hat to all I meet
and they wave back to me
And blackbirds sing so loud
and sweet from every
greenwood tree.

CHORUS

High overhead the skylarks
wing, they never rest at
home. But just like me they
love to sing, as o'er the world
I roam.

THE HIKING SONG

Tune: Caisson Song

Over hill, over dale, We will
hit the greenwood trail As
the Cub Scouts go hiking
along.

In and out, all around, you
will never see us frown, As
the Cub Scouts go hiking
along.
And it's hi, hi, hee, The Cub
Scouts are for me. Shout out
our name and shout it strong.
CUB SCOUTS!!! Wher'eer we
go, we will always know
That the Cub Scouts go
hiking along.

PAGE 4 - APRIL - MOUNTAINS OF AMERICA GEOLOGIST/FAMILY MEMBER

MARCH ALONG Tune: This Old Man

March along, March along.
Lift your feet up off the
ground.
And we'll march and sing a
happy little song,
As we go a marching on.

Family Member:

Create a full weeks menus for your family using a budget and foods on hand - A den pot luck could end the effort.

Make and use family job charts for a 4 week period.
Develop ways to save energy - learn to compute energy saved into amount of money saved.

List and print inexpensive family fun ideas. Pass them out at a pack meeting.

Learn how to do laundry properly. Do it for 1 week.

SLIDE OF THE MONTH:

Ladybug

BY BILL FLEMING

This bug is one colorful lady.

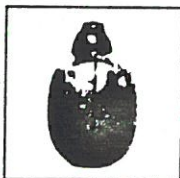

HAVE YOU EVER caught Hippodamia convergens? No, it's not a disease, it's Latin for the convergent lady beetle, or simply, the ladybug.

These tiny beetles that look like orange split peas are collected in great numbers and distributed in farmers' fields. They protect crops by eating plant lice and other pests. It takes about 1,500 ladybugs to make an ounce, and farmers use them by the ton.

Imagine trying to catch 1,500 beetles.

It's much easier to carve one out of wood to slide up your neckerchief.

Here's how:

1. Using a coping saw, rough out the ladybug shape from a 1-by-1½-by-2¼-inch block of basswood or sugar pine as shown in the top and side views. Whittle the detail with a sharp pocket-knife.

2. After it is well rounded, sand it thoroughly with coarse sandpaper. Next, go over it with fine sandpaper.

3. Make a long "V" cut down the center of the bug's back to show the separation in the shell. You can do this with a knife or triangular file.

4. Cut the loop out of a ¼-by-1½-inch block of wood as shown in the diagram. Glue it to the underside of the ladybug.

5. When the loop is secure, seal the en-

tire slide with shellac. When this dries, ready the slide for painting by sanding it once more with fine sandpaper.

6. Perfecting the color of the beetle is more important than carving its exact shape. Mix red hobby enamel with yellow until you have a bright orange color. Then carefully add drops of brown paint and mix until you match the natural bright, brownish-orange color of a ladybug's shell. Paint the shell.

7. When dry, paint the ladybug's head black and dab 12 dots of black paint on the orange shell. Why 12? Have you never counted the number of black dots on a ladybug's back? Wait until this dries and finish off with a coat of glossy varnish.

Vada! A Hippodamia convergens neckerchief slide. ☺

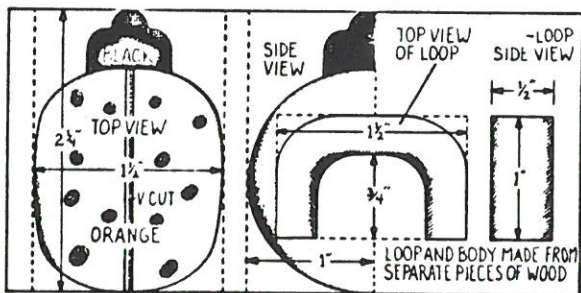

PAGE 5 - APRIL - MOUNTAINS OF AMERICA GEOLOGIST/FAMILY MEMBER

WEBELOS HIKER



Fig. 8-6
WEBELOS HIKER
2" x 2"

» Requirements:

1. In one year's time, participate in four (4) outdoor hiking activities.
 2. The outdoor experience must have a planned program to cover the outdoor requirements for the following activity awards:
 - Outdoorsman
 - Forester
 - Naturalist
 - Geologist
 3. One of the outdoor hiking activities should be a Parent/Son experience.
 4. The Unit Leader is to submit a minimum of four (4) Local Tour Permits and have the Council H.A.T. representative sign and approve the award application.
5. As a Webelos, this patch will be worn on the right pocket of the uniform.
 6. When the Webelos becomes a Scout, he then puts this award on a "brag sheet", his pack, or pack flap.
 7. All four (4) Activity Badges must be earned prior to receiving the Webelos Hiker Patch.
 8. Webelos do not all have to go on the same hikes - but each boy must have four (4) outdoor experiences to qualify for the award.
 9. Each hiking activity must be a minimum of one (1) mile.
 10. The Specific Requirements shall supersede the General Requirements if there is an area of conflict.

Cub/Webelos Awards for Western Los Angeles County

CUB CONSERVATION

» Requirements:

1. Must have approval from agency or representative of area where conservation project is going to be done prior to beginning work on this project.
2. The B.S.A. Local Tour Permit is required.
3. The Tour Permit and Award Application Form must be signed (on backside) by the agency representative to receive credit for hours worked.
4. Must be an approved unit function.
5. Each participant must be a currently registered Cub or Webelos Scout including currently registered Leaders.
6. All award applications shall be approved by your H.A.T. Council Representative before awards will be issued.
7. The award is divided into three separate five-hour segments with the "patch" awarded together with the first five-hour "segment-patch" upon completion of five hours of approved conservation work.

NOTE: This award WILL NOT be issued for picking up trash. The Mission Council Anti-Litter Award is available for "trash pick-up" activities.

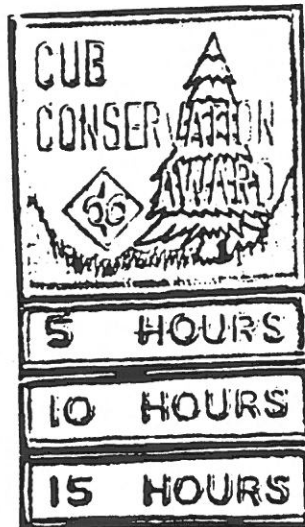

Fig. 8-1
CUB CONSERVATION
3" x 5-1/2" w/segments

SLIDE OF THE MONTH:

Turtle shell

Mobby enamel will give this slide that hard-shell finish.

BY BILL D. FLEMING



EVEN IF YOU don't belong to the turtle patrol, you'll enjoy carving this simple, but attractive, neckerchief slide.

Before starting, observe your pet turtle or go to a pet shop and take notes on the shape and coloring of one. This will help you make an accurate wooden replica of a turtle shell.

You will need

- 2 1/2-by-2-by-1/4-inch block of sugar pine or basswood

- 1 1/2-by-1-by-1/2-inch block of wood.

- a sharp pocketknife.

- wood glue, clamp, pencil.

- sandpaper, hobby enamel.

1. Trace the oval pattern of figure 1 on the larger block of wood. I prefer basswood because it's soft and easy to whittle, yet its dense grain makes it tough and durable like a turtle's shell.

2. Cut out the basic oval shape using a coping saw or band saw.

3. Before starting to whittle, cut the loop from the smaller block as shown in figure 4.

4. Attach the loop to the back of the large block (in the center) with wood glue. Use a small clamp to hold it in place and let it dry

overnight. Clamping forces the glue into the pores of the wood and makes the connection stronger. Gluing the loop on first gives you more to hold on to when you whittle.

4. Now it's time to whittle. Make sure your knife is sharp.

You are going to simulate the shell of the red-eared slider, a common aquarium turtle. It's peaked at the center rather than shaped like a box-turtle shell. As you carve, follow figure 2 for the side-view shape and figure 3 for the end view.

5. After shaping the shell following the pattern, make small "V" cuts in the plates. Plates on most turtles are not very uniform, so don't be concerned if yours are not perfect.

6. When you are satisfied with the shape, sand the shell with medium sandpaper and seal it with shellac. The sealer raises the nap of the wood, leaving it rough. Sand it smooth before painting.

7. Now, check your notes to help you choose the right color paint. You may want to use dark green hobby enamel, and accent the plates by painting the inside of the "V" cuts blue.

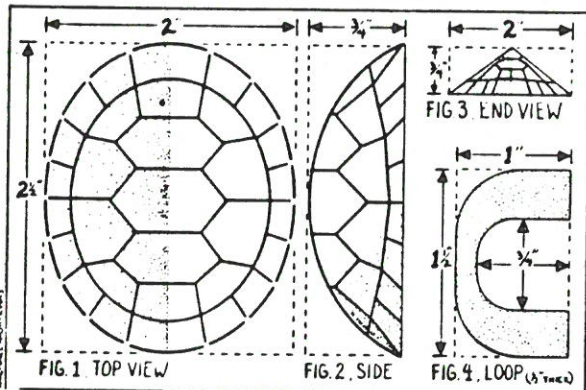

SLIDE OF THE MONTH:

Diamondback

BY LEW WESTON

Here's a "fang-tastic" slide to add to your collection.



YOU'RE BOUND to get stares (and compliments) when your buddies see this realistic rattler hugging your neckerchief.

In this neat design, Ol' Fang Mouth coils around your neckerchief and slips his head over the top, just underneath your chin. The diamondback-rattlesnake slide is a little more challenging than others we've shown in this column, but the final product is worth the effort.

Use soft pine, basswood or cedar. Bore out a 3/4-inch center hole before you carve the snake's shape. Be sure you don't bore into his head area.

Carve out the coils of the snake, allowing an extra "hump" of wood for the tail and rattle. Then carve the throat and head as shown in the diagrams, and notch out the gaping mouth. Round off the roughed-out shape some more with your pocketknife, then go over it with sandpaper.

Gouge out the mouth to form a rim of lower teeth. The two fangs are toothpick ends glued into small holes drilled into the upper jaw.

Next, make small V-cuts to form the eyes (as shown) and nostrils. Also, carve the forked tongue with well-placed V-cuts in the lower jaw.

You also will use V-cuts to create the scaled look on the body. Use the two moves shown in the diagram to help make this diamond shape. (You don't need to do this in the snake's throat area, because it will be hidden by your neckerchief.)

For the rattle, I cut a thin line down its length and made several bowed cuts across the line.

If you used a block of cedar for this slide, you may want to leave it unpainted to simulate the natural coloring of a desert rattler.

If you wish to paint your diamondback slide, I suggest using a dark gray or dull black paint for the body. When dry, paint crisscrossing white lines over the body to form separate, black diamond shapes. Paint the mouth and fangs white, the tongue, eyes and nostrils, red.

With careful carving and painting, you'll create a "fang-tastic" addition to your neckerchief slide collection.

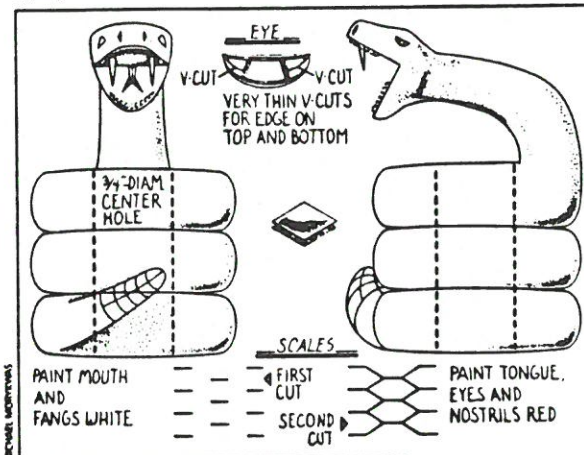

PAGE 7 - APRIL - MOUNTAINS OF AMERICA GEOLOGIST/FAMILY MEMBER

COTTONTAIL RABBIT

MATERIALS

Cardboard or poster board
Felt, pink, red, black, blue
Glue
Scissors
2 Black Buttons
Black yarn

DIRECTIONS

1. Draw a rabbit shape on a piece of cardboard by making a large circle for the body and a smaller circle for the head. Add two ears to the head and a small circle for the tail.
2. Cut the rabbit shape out in one piece, as shown in the diagram.
3. Glue pink felt on the ears, and trim around the edges with scissors.
4. Outline the ears with glue, and place cottonballs in the glue.
5. Spread glue over the rest of the rabbit, and place more cottonballs in the glue, completely covering the rabbit.
6. Glue on eyes, a nose, and a bow tie, all made from felt.
7. Glue buttons onto the body and black yarn for the mouth.
8. Attach a piece of short string to the top of the rabbit to hang it as a wall decoration.



APRIL FOOL SURPRISE

MATERIALS

Can with snap top lid
Construction paper
Markers or crayons
Glue
Scissors

DIRECTIONS

1. Fold a paper spring that will fit inside the can. The spring when flattened should be the height of the can. This will make the spring long enough to pop out of the can.
2. Glue a pink construction paper face onto the end of the spring. Draw in features with crayons or markers.
3. Cover the can with construction paper and write "POPCORN" on the outside.
4. Offer the can to your friends, and see how surprised they will be.

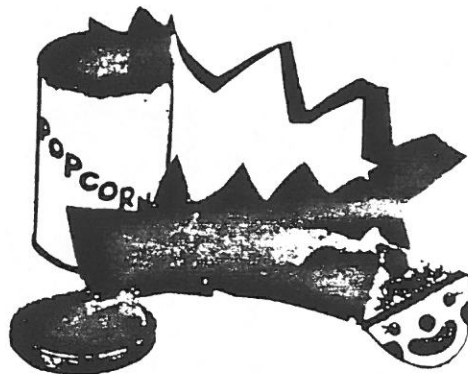

Pedro neckerchief slide

using carbon
paper trace design
onto plastic material

back view
glue pipe cleaner
to back for
loop for neck-
erchief.



PAGE 8 - APRIL - MOUNTAINS OF AMERICA GEOLOGIST/FAMILY MEMBER

EGG CARTON EASTER BABIES

MATERIALS

Foam egg cartons
Felt
Paper
Tiny Pom Poms
Yarn
Sequins
Black Marker
Scissors
Glue

DIRECTIONS

1. Remove the front row of six egg cups.
2. Invert the carton. (Lid becomes the base, remaining cups become tops of the heads.)
3. Glue sides together and fill the base with Easter Grass.

FOR BABY BUNNIES

1. Cut twelve inner and outer ears from paper. Glue inner ears on top or outer ears. Glue one pair of ears to each bunny head.
2. Cut eyes from paper and glue to faces. Glue a tiny pom-pom nose and white thread whiskers to each bunny face.
3. Glue a small yarn bow to the front of each bunny.

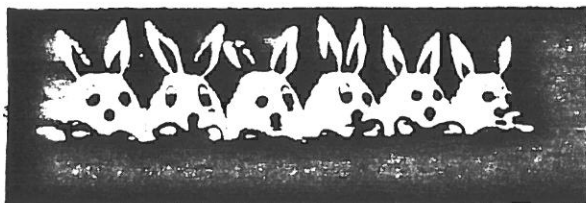

FOR CHICKS

1. Cut pointed hats from a contrasting colored egg cup. Glue hats to heads of chicks. Glue a yarn bow on top of each hat.
2. Cut eyes from paper and beaks from felt and glue to front of chicks.
3. Cut tiny bow ties from felt. Glue one to the front of each chick's body.
4. Glue a sequin in the center of each tie.



rope neckerchief
slide

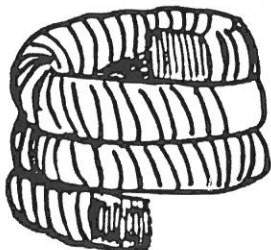

Whip both ends of an eight inch piece of rope. Then lay a bead of hot glue along the rope and turn the rope in a circle forming an opening about the width of a finger for your neckerchief to fit through.

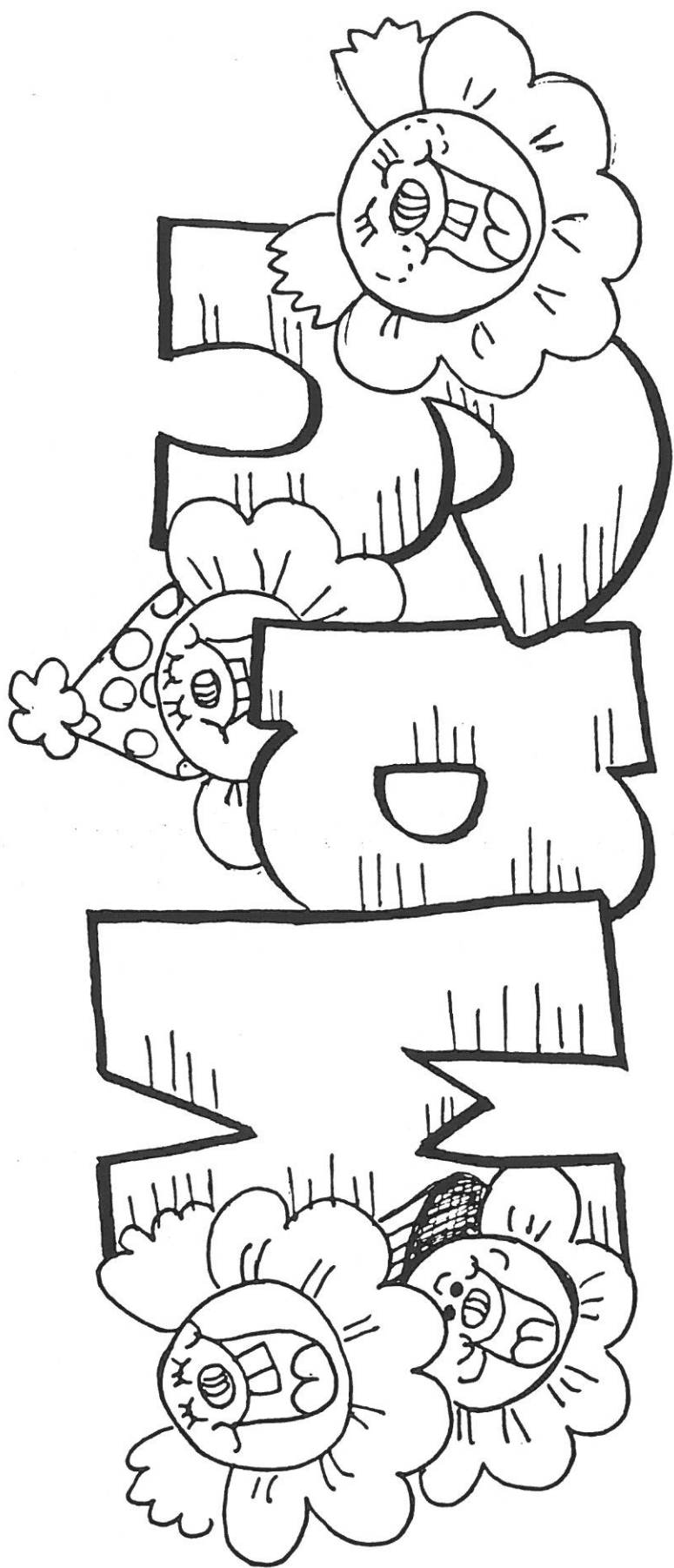

**Under the Big Top
Outdoorsman/Showman**

**MAY
UNDER THE BIG TOP
OUTDOORSMAN/SHOWMAN**

SONGS

**WILLOUGHBY WALLABY
WEE**

Willoughby wallaby wee,
an elephant sat on me
" " woo,
and elephant sat on you.
" " Wustin,
an elephant sat on Justin
" " Wania,
and elephant sat on Tania
(Note: " " = Willoughby
wallaby)

CALLIOPE SONG

Divide the meeting into
four or five groups. Begin
with the first group and
bring each of the others in
one at a time.

1st Group sings:

Um-pah-pah

2nd Group sings:

Um-sss-sss

3rd Group sings:

Um-peep-peep

4th Group sings:

Um-tweedle-tweedle

Last group sings either th
Melody of "Daisy, Daisy" or
"Where has my Little Dog
Gone?" or "The more We Get
Together". You can also hold
your nose while humming
"The More We Get Together"

**THE CIRCUS COMES TO
TOWN**

Tune: When Johnny Comes
Marching Home

The Cub Scout circus comes
to town
Hurrah! Hurrah!
The elephants, monkeys and
the clowns
Hurrah! Hurrah!
The big brass band, the
merry-go-round,
The Midway acts with lost
of sound
And We'll all be there
When the Circus comes to
town.

ALICE THE CAMEL

Alice the camel has 5 humps,
Alice the camel has 5 humps
Alice the camel has 5 humps,
So go Alice go.....
BOOM...BOOM...BOOM...BOOM
(Hip motion side to side)

Continue until you get to...
Alice the camel has no
humps, Alice the Camel has
no humps Alice the Camel
has no humps, cause Alice is
a horse!

(Best done with everyone
putting their arms around
others, either forming a

**PAGE 2 - MAY - UNDER THE BIG TOP
OUTDOORSMAN/SHOWMAN**

circle or a line. Whenever you say "humps", you bend your knees).

I MAY NEVER
Tune: Old Grey Mare

I may never ride on a circus horse
Work in the lion's cage
Walk on the tightrope
I may never work with the clown force
But I can watch all , I can watch all.
I may never ride a circus horse
Work in the lion's cage
Walk on the tightrope
I may never work with the clown force
But I can Watch it all.



Cowboy chaps tie slide
USE leather or vinyl

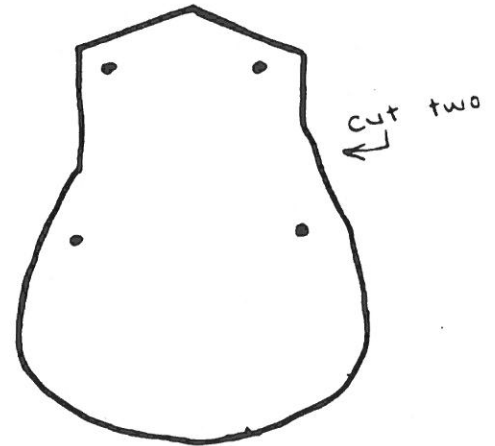
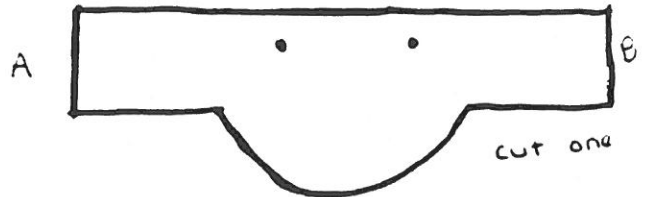

USE paper brads
to decorate and hold
chaps together
(need four)

Sew ends A + B
together

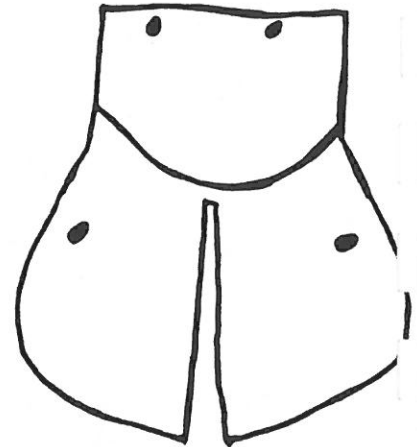

fold in
half



PAGE 3 - MAY - UNDER THE BIG TOP OUTDOORSMAN/SHOWMAN

WEBELOS HIKER



Fig. 4-8
WEBELOS HIKER
2" x 2"

» Requirements for Webelos Hiker:

1. Hiker must be a member of a Webelos Den on a scheduled outing.
2. Hiker must have earned the Forester Activity Badge.
3. Hiker must have taken a day training hike of at least 2-1/2 miles before this award hike.
4. Hiker must complete this award in a non-urban area. It must be at least five (5) miles round trip and preferably less than eight (8) miles.
5. Every Webelos should be in uniform and carry his own personal equipment, including a snack, drinking water, and jacket.

» Requirements for Webelos Hike Leader:

1. Leader must meet all applicable San Diego Council General Requirements (Form HA2000). This is supplied by the Council Service Center.



2. Leader should get approval (by telephone is OK) from H.A.T. representative during early planning stages regarding trail to be used, etc.
3. Webelos unit must be accompanied by two (2) adults (21 years old or older), one of which must have a current American Red Cross Multimedia First-Aid car or better in his possession.
4. Leader to Webelos ratio must be at least two (2) leaders for 8 boys and not less than two (2) adults for any hike.
5. Leader must carry a parent release (emergency consent) for each Webelos which specifies the outing date covered. Form is available at Council Service Center.
6. Local Tour Permits must be obtained from Council Office before hike and carried by hike leader on the hike.

WEBELOS UNDER THE STARS

Webelos, Den Chiefs and Scouters can earn this overnight camping patch by planning and attending any Webelos Den overnight campout. However, this patch cannot be earned when working on any other High Adventure Award.

» Requirements:

1. Two weeks prior to the overnight campout, a Local Tour Permit must be filed with your local Council Office.
2. The patch is earned by completing a Den overnight campout where Webelos are working on various Activity Badges. This could be a family campout that Webelos, parents, and Den Leaders are attending.
3. The patch may be worn on the right shirt pocket of the Webelos Uniform as a temporary patch.
4. While the overnight campout does not have to be at a Council Camp, it is recommended.
5. At least one adult should have a first-aid kit and be qualified in basic first-aid.



Fig. 1-4
UNDER THE STARS
2" x 2"

MT. BADEN-POWELL

» Requirements:

1. Use proper Council High Adventure Award Application.
2. Day hikes require B.S.A. Tour Permit, roster and itinerary.
3. One patch per person for each climb.
4. Award can be earned by units who climb Mt. Baden-Powell as a requirement for another award. Submit proof of completion of other award requirements and these requirements.
5. The trail from Vincent Gap ascends Mt. Baden-Powell by switchbacks. In places it is steep and dangerous. Great care should be taken not to leave the trail or dislodge rocks which could injure climbers below.
6. Camping facilities in the area of Mt. Baden-Powell are limited.



Fig. 1-2
MT. BADEN-POWELL
2" x 2"

- A. There are no camping facilities in Vincent Gap itself.
- B. No fires of any kind are permitted on the mountain, hence camping at Lamel Springs on the trail must be a cold camp. Lamel Springs is without water at certain times of the year.



PAGE 4 - MAY - UNDER THE BIG TOP OUTDOORSMAN/SHOWMAN

COFFEE FILTER FLOWERS FOR MOM

MATERIALS
Coffee Filters
Food Coloring
Waxed paper
Paper Towels
Pipe Cleaners

DIRECTIONS

1. Fold a coffee filter into quarters.
2. Dampen the filter with water.
3. Add drops of food coloring onto the filter in any pattern.
4. Press the filter between pieces of waxed paper to spread the color.
5. Open the filter, and let it dry on paper towels.
6. Again, fold the filter in quarters, forming a point at the bottom.
7. Twist a pipe cleaner around the point for a stem.
8. Place several in a vase for mom or use to decorate the front of a Mother's Day Card.



PINCUSHION FIGURE

MATERIALS
Empty plastic-foam thread spool
Styrofoam disposable cup
Yarn for hair
Yarn for dress
Hook and eye set
Glue
Button
Straight Pin
Safety pins

DIRECTIONS

1. Glue yarn to the top of the spool for the head.
2. Sew part of a hook and eye set to the bangs. This will be the eyes and nose.
3. Glue on a yarn mouth.
4. Wrap yarn closely around the upside-cup for the body, using a drop of glue here and there to hold the yarn in place.
5. Glue the head to the body.
6. Attach a button hat with a straight pin.
7. Insert two safety pins for arms.
8. The figure will hold many pins and needles.



Outdoorsman:

Learn by heart: Square knot
Clove hitch
Tautline hitch
Bowline
2 half hitches

Have family campout - Prepare a meal for parents - Relay races to set up tents - Practice campsite set up for Camporee.

**PAGE 5 - MAY - UNDER THE BIG TOP
OUTDOORSMAN/SHOWMAN**

CRAZY CIRCUS CRITTERS



THE GWIRT

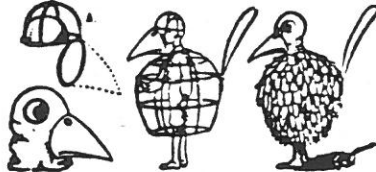

THE FRAME OF THE GWIRT IS MADE OF WIRE, COVERED WITH CHEESE CLOTH ON WHICH IS SEWED SCRAPS AND PIECES OF CLOTH OF ALL COLORS. THE HEAD IS AN OLD DEBBY HAT WITH THE BRIM CUT OFF & WIRE IS STICKED AROUND EDGE OF HAT (FIG. A) THE BEAK IS MADE OF CARDBOARD PAINTED YELLOW. HOLES CUT FOR NOSE & EYES AS HELP HOLES. THE HEAD FRAME IS COVERED WITH BUCKRAM RED COTTON CLOTH, IT IS LEFT HANGING LOOSE AT NECK. THE TAIL IS A LOOP OF WIRE COVERED WITH ANY BRIGHT COLOR BY A PAIR OF WHITE COTTON STOCKINGS FOR LEGS AND FEET, BRIGHT YELLOW. THESE ARE WORN OVER THE SHOES.

THE ORFF

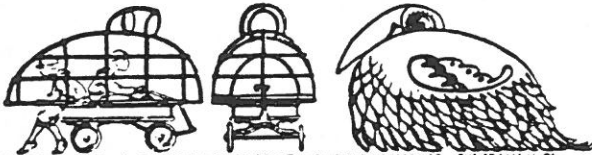

BUILT ON A WAGON THIS BIRD WILL GLIDE ABOUT IN AN AMUSING MANNER. THE FRAME IS OF WIRE FASTENED TO 1 1/2" LUMBER THAT CAN BE CLAMPED TO THE WAGON. COVER THE FRAME WITH CHEESE CLOTH AND SEW ON COLORED BUCK CUT FEATHER SHAPES. LEAVE HELP HOLES FOR DRIVE.

THE GROTZ

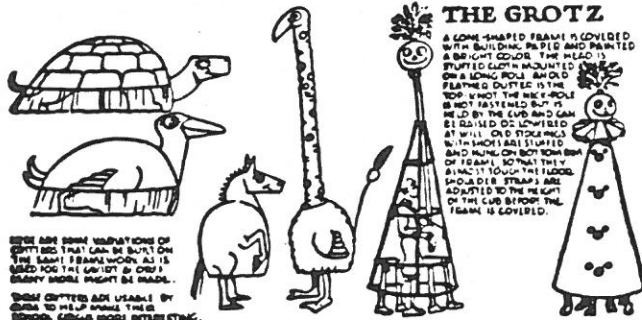

A CONE-SHAPED FRAME IS COVERED WITH BUCKRAM PAPER AND PAINTED A BRIGHT COLOR. THE HEAD IS STUFFED CLOTH MOUNTED ON A LONG POLE. AN OLD FEATHERED OUTFIT IS THE TOP. WHOT THE HOLE IS NOT FASTENED BUT IT HELD BY THE CUP AND CAN BE DASHED OR LOOSED AT WILL. OLD STOCKINGS WITH HOLES STUFFED AND HUNG ON BOTH SIDES OF FRAME, SO THAT THEY SLING TO THE FEET. SHOULD BE STRUNG AND ADJUSTED TO THE HEIGHT OF THE CUP BEHIND THE FRAME IS COVERED.

HERE ARE SOME VARIATIONS OF CRITTERS THAT CAN BE BUILT ON THE SAME FRAME WORK. ALL IS USED FOR THE GWIRT & ORFF. MANY MORE MIGHT BE MADE. THESE CRITTERS ARE USABLE BY GUNS TO HELP MAKE THEM SCHOOL. CIRCUS MODE ENTERTAINING.

LEATHER AND VINYL SLIDES



CLOWN FACE
DRAW FACE WITH PERMANENT MARKER. GLUE ON WIGGLY EYES OR SEW ON BUTTONS.

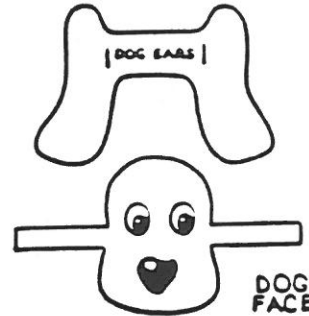

DOG FACE

PLASTIC FLOWERS



CLOWN'S HAIR
INSERT TABS THROUGH SLOTS.

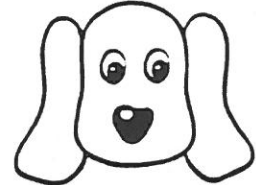

LEATHER AND VINYL SLIDES

Use scrap leather or vinyl to make these slides.

1. Cut desired shape. Some possibilities are bobcat, wolf, and bear faces, arrowhead, basketball, baseball glove, elephant, owl.
2. Glue (contact cement works best), staple, or rivet a leather or vinyl loop onto the back.

elephant face tie slide
use leather or vinyl

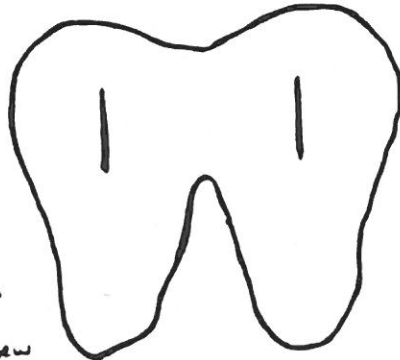

cut two slits in ears
place A & B ends through
over hand sew A & B together

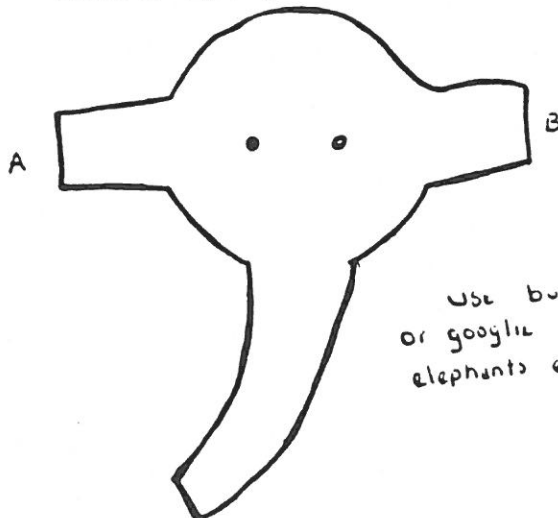

Use buttons or googlie eyes for elephants eyes

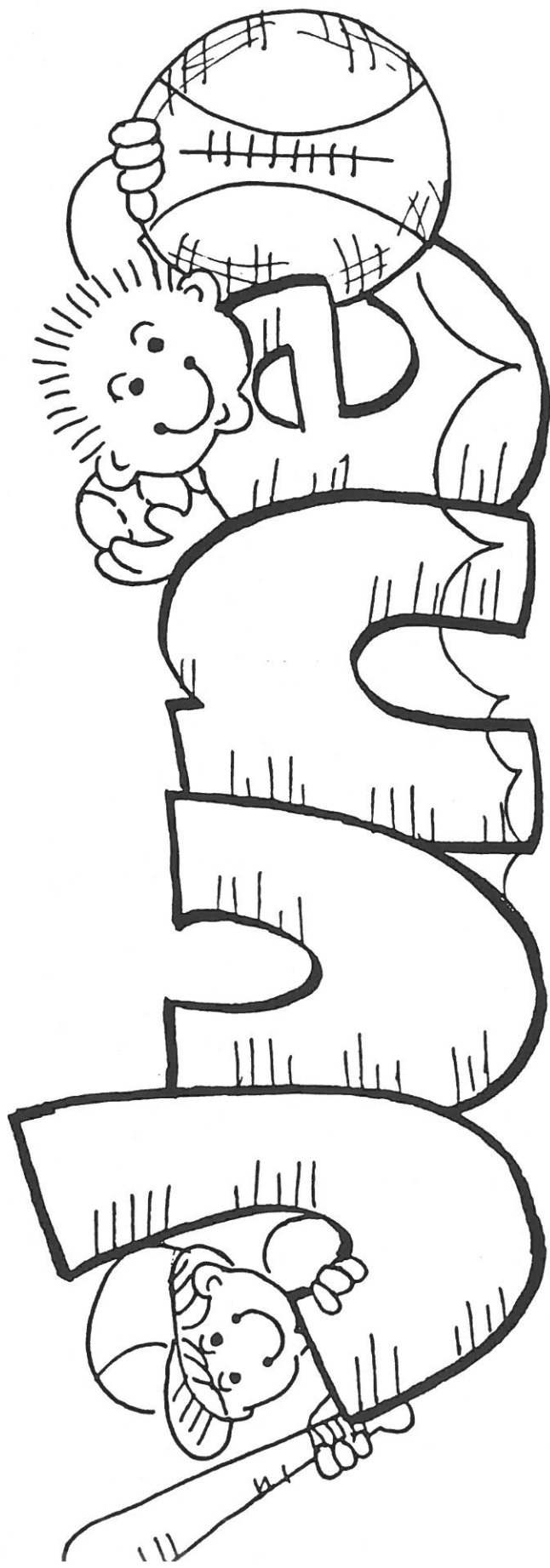

**Sports Arena
Naturalist/Athlete**

**JUNE
SPORTS ARENA
NATURALIST/ATHLETE**



**SONGS
GET IN SHAPE
Tune: Reuben, Reuben**

Throw the ball to each other,
Kick it high into the sky,
Get in shape for sports and
games,
We will win more if we try.

**BELT LOOPS
Tune: Camptown Races**

Come Cub Scouts join the
sports
Doo Dah, Doo Dah
On the baseball field and
tennis court
Oh Doo Dah Day!

Going to earn belt loops
Going to wear them on my
belt
Won't you come and earn
some now?
Oh Doo Dah Day!

**SPORTS SONG
Tune: Twinkle, Twinkle,
Little Star**

Baseball, Soccer, Archery,
Playing sports is fun to me.
Lots of sports for everyone
You can come and have some
fun.

Marbles, tennis, basketball
Come and play there's room
for all.

**SPORTS PROGRAM
Tune: Found a Peanut**

Played Volleyball
Played Basketball
And played baseball, too.
I learned to be a good sport
Since I learned the Cub Scout
Rules.

Learned Archery
Learned to Snow Ski
And my Dad did it with me
Earned a sports pin and a
letter
Get your dad and earn one,
too.



PAGE 4 - JUNE - SPORTS ARENA NATURALIST/ATHLETE

CLIPBOARD FOR DAD

MATERIALS

Piece of cardboard
Construction Paper
Fabric
Glue
Scissors
Hole Punch
Yarn
Spring Clothespin
Marker

DIRECTIONS

1. Cover a piece of cardboard with construction paper.
2. Cut a necktie shape from fabric, and glue it to one side of the board.
3. Glue on a spring clip clothespin. Print "DAD" on the clothespin with a marker.
4. Punch two holes near the top of the cardboard.
5. Thread yarn through the holes for a hanger.
6. Put a piece of notepaper in the clothespin and write on a Father's Day message.

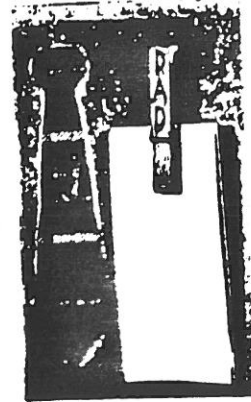

LOG EXTENSION CORD HOLDERS

MATERIALS

Empty paper tube, or toilet paper rolls
Woodgrain contact paper
Shoobox
Square stickers

DIRECTIONS

1. Cut paper rolls to measure about 1" longer than the folded cords.
2. Cover each log with woodgrain contact paper.
3. Insert extension cords and label each log holder as the size of the cord.
4. For the log bin, cut the front off a shoe box.
5. Cover the inside and out with paper.
6. Stack the logs inside the box.
7. Make as many cardboard roll holders as you have extension cords, labeling each one.
8. Stack the rolls in the log bin and place on a convenient shelf.
9. Dad will be able to pull out the cord he needs at one glance.

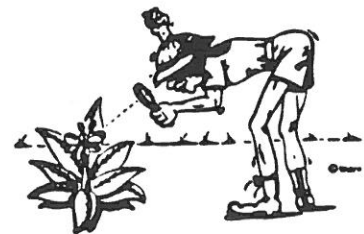

PAGE 5 - JUNE - SPORTS ARENA NATURALIST/ATHLETE

FATHER'S DAY HAIRY LARRY CUP

MATERIALS

Construction paper
Clear plastic cups
Soil
Seeds
Glue
Scissors
Popsicle stick

DIRECTIONS

1. Cut out the face patterns and glue to the plastic cup.
2. Fill cup 2/3 full with water.
3. Sprinkle 1/2 teaspoon seeds on top of soil.
4. Sprinkle a little soil on top and water.
5. Always keep it moist.
6. Keep in a sunny place.
7. In 7 to 10 days he's ready to have a hair cut.
8. Print "To A Super Dad" on a small piece of paper and glue to an ice cream stick. Put in cup as a plant stick.



I KNOW MY DAD

1. Year he was born _____
2. His favorite color _____
3. Name of his High School _____
4. The color of his eyes _____
5. His favorite school subject _____
6. His height _____
7. His weight _____
8. His favorite sport _____
9. His nickname as a kid _____
10. His favorite TV show _____
11. What makes Dad laugh most _____

12. What makes Dad the maddest _____

FATHER'S DAY CARD

MATERIALS

Construction paper
Newspapers and sport magazines
Glue
Scissors

DIRECTIONS

Outside

1. Fold a piece of construction paper in half.
2. Cover the front with colorful sports pictures from newspapers or magazines.
3. Cut a baseball bat shape from paper and print "DAD!" on it.
4. Glue this to the front of the card.

Inside

1. Xerox the form below and have each boy fill it out according to what he thinks the answers are with no help from anyone.
2. Glue to the left hand inside cover of the card.
3. Have boys write a message on the right hand side.



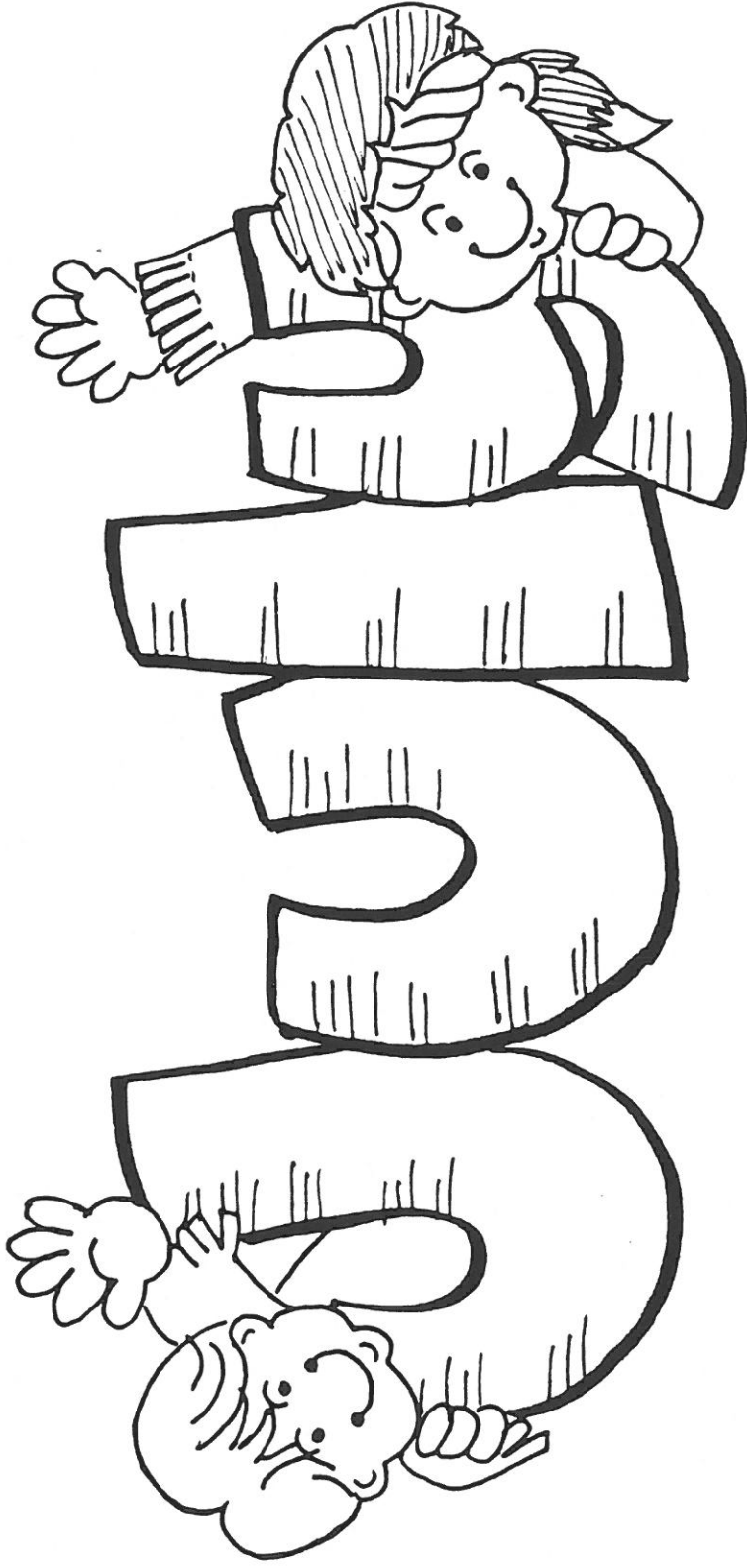

**Buckskin Pioneers
Aquanaut/Forester**

**JULY
BUCKSKIN PIONEERS
AQUANAUT/FORESTER**



**SONGS
THE BALLAD OF DAVEY
CROCKETT**

Born on a mountain top in
Tennessee, Greenest state
in the land of the free,
Raised in the woods so's
he knew every tree Kilt
him a B'ar when he was
only three. Davy-Davy
Crockett, King of the Wild
Frontier.

In Eighteen Thirteen the
Creeks uprose, Addin'
redskin arrows to the
country's woes, Now, injun
figthin' is somethin' he
knows So he shoulders his
rifle and off he goes
Davy-Davy Crockett, the
man who know no fear.

Off through the woods
He's a-marchin' along
Makin' up yarns an'a
singin' a song' Itchin fer
fightin' an' rightin' a
wrong He's ringy as a b'ar
an' twice as strong
Davy-Davy Crockett, The
Buckskin Buccaneer.

Fought single-handed
through the injun war Till
the Creeks was shipped an'

peace was in store An'
while he was handlin' the
risky chore, made himself
a legend evermore.
Davy-Davy Crockett-King
of the Wild Frontier

He gave his word and he
gave his hand That his
injun friends could keep
their land, An' the rest of
his life he took the stand
That justice was due every
redskin band. Davy-Davy
Crockett, Holdin' his
promise dear.

Home fer the winter with
his family, Happy as
squirrels in the Ol' gum
tree Bein' the father he
wanted to be Close to his
boys as the Pod an' the
pea Davy-Davy Crockett,
Holdin' his youn 'uns dear.

He went off to Congress
an' served a spell, Fixin' up
the Gover'ment an' laws as
well, Took over
Washin'ton so we heard to
tell An', patched up the
crack in the Liberty Bell
Davy-Davy Crockett, Seein'
his duty clear!

Him an' his jokes traveled
all through the land, An,

his speeches made him friends to beat the band. His politickin' was their favorite brand. An' everyone wanted to shake his hand. Davy-Davy Crockett, Helpin' His legend grow.

He heard of Houston an' Austin an' so To the Texas plains he jest had to go Where freedom was fightin' another foe, An' they needed him at the Alamo. Davy, Davy Crockett, the man who don't know fear.

His land is biggest and his land is best, From grassy plains to the mountain crest, He's ahead of us all meetin' the test, Followin' his legend into the West. Davy-Davy Crockett, King of the wild frontier...



SIDE OF THE MOUNTAIN:

Square knot

BY BILL FLEMING

You can paint this slide in the colors of your rank.



HERE'S A CHALLENGING neckerchief slide you can carve to fulfill one of the requirements for the Wood Carving merit badge.

- You will need:
- 1 1/4-by-1/2-by-1 1/2-inch block of basswood or white pine.
 - a sharp pocketknife or hobby knife.

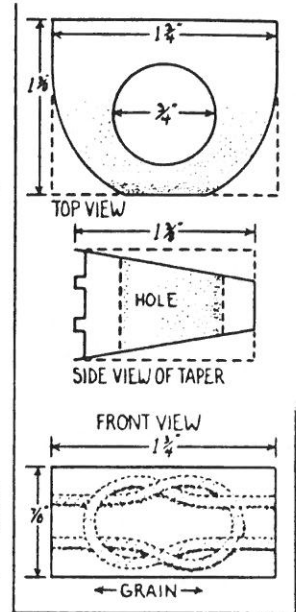

POCKET KNIFE SHEATH

For this practical project, you'll need the following:

- Scrap of leather big enough for the knife
- Paper for pattern
- Knife to cut leather
- Rotary punch
- About 2 feet of leather or vinyl lacing
- Leather tools or initials

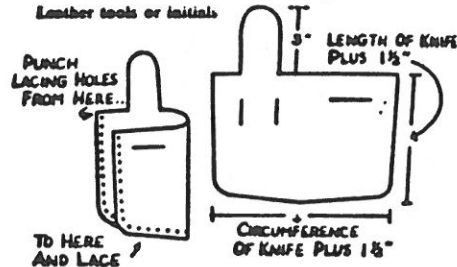

POCKET KNIFE SHEATH

1. Make a paper pattern to fit the knife, allowing the ears length and width as shown. Evenly space marks for the holes. Cut leather by the pattern and mark holes.
2. Cut the slots as shown. Be certain the two vertical slots will fit the belt.
3. If desired, tool a design or mark with initials.
4. Fold over. Hold edges together securely. Punch through both layers at once.
5. Use a whip stitch to lace the two edges together, beginning at the top and ended at the bottom as shown.
6. Slip knife sheath onto belt through the slots in back. Insert knife, fold tab over top of it, and slide tab into front slot.

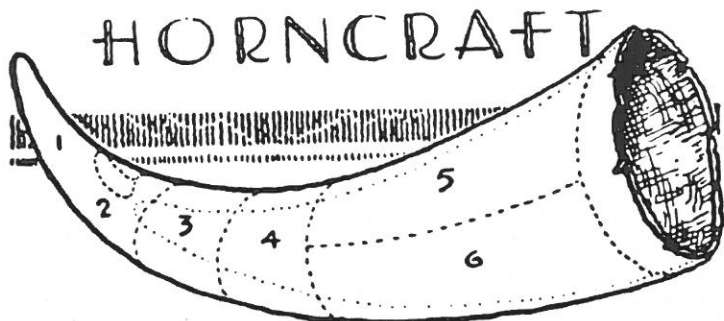

THE DOTTED LINES ABOVE SHOW APPROXIMATE THICKNESS OF A HORN. THE SHORT DASHES SHOW PARTS OF HORN USED FOR CERTAIN ARTICLES. THE NUMBERS CORRESPOND TO THE NUMBERED ARTICLES ILLUSTRATED BELOW.

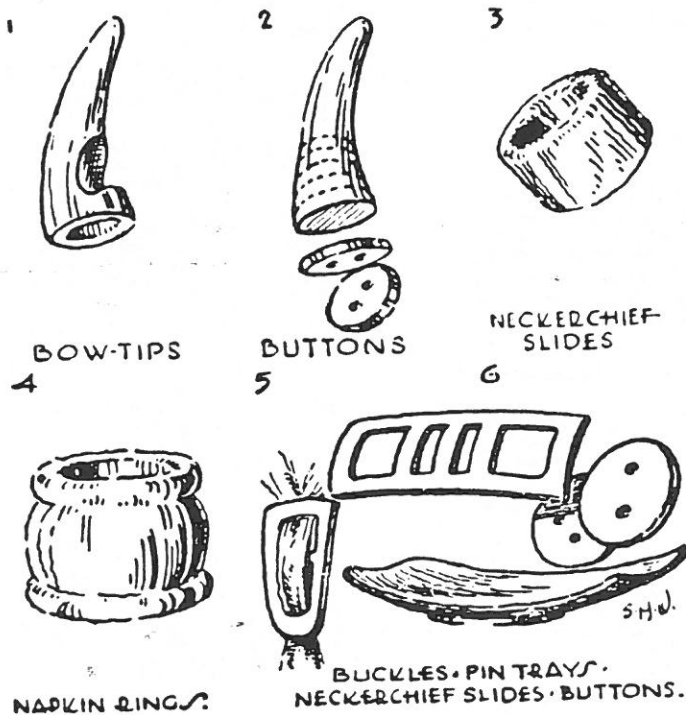

SLIDE OF THE MONTH:

Camp saw

BY BILL ANDREWS

Be on the cutting edge of neckerchief fashion.

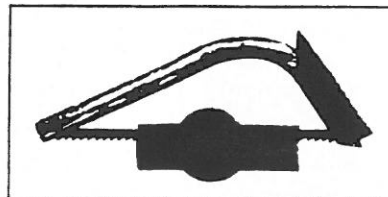

SAW A SAW the other day, and thought it would make a sharp neckerchief slide. But if you asked me if this simulated saw could saw wood, I'd have to admit it couldn't cut the mustard.

You'll need the following:

- aluminum wire—the type used to secure chain link fences
- vise, wire cutters
- wood dowel
- coping saw
- hacksaw
- Super Glue
- rubber or leather, tacks

1. Bend wire into the shape shown.
2. Secure wire in a vise and carefully cut slots into its ends, about 1/8 inch deep, with a hacksaw.
3. Cut an old or broken coping-saw blade so the ends fit within the aluminum wire.

Wire cutters or tin snips should cut the coping-saw blade.

4. Place a drop of Super Glue into each slot and insert the blade. Gently tap the ends of the wire with a hammer to pinch the blade.

5. Cut a piece of heavy paper in the shape shown and glue to the saw handle. This represents the locking device on camp saws.

6. Cut into a dowel about a third of the way with a coping saw.

7. Glue the saw into the cut. Add to the dowel a leather or rubber strap to slip around your neckerchief. You can glue it or use tacks. (The slide in the photo has a carved, wooden loop to hold the neckerchief.)

That's all there is to this saw slide, you see. ☺

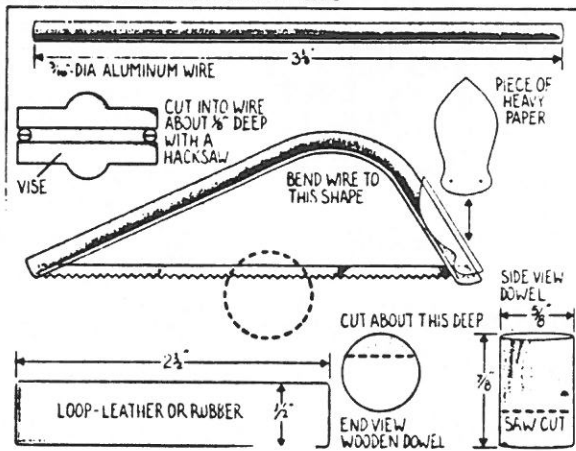

Cut a circle of about three inches diameter from heavy card board or plastic bottle scrap. Add real feather fluffs or construction paper feathers.

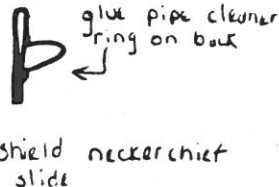

whittle from 1/4 inch soft wood. Drill small holes for cord loop. Paint as desired.



PAGE 4 - JULY - BUCKSKIN PIONEERS AQUANAUT/FORESTER

CUB DAY HIKER



Fig. 5-2
CUB DAY HIKER
2" x 2"

This award is designed to promote the outdoor program in the Cub Pack and give recognition to the participants.

Requirements:

1. File a Local Tour Permit one week prior to the hike.
2. The hike should take a minimum of two (2) hours to complete.
3. Each Cub Scout should be in uniform (if available) and carry his personal equipment such as lunch, drinking water, and extra clothing (jacket, etc.).
4. Each Cub Scout should bring a pencil and paper to take notes, and each Den is to submit a short hike report to the Pack.
5. At least one adult in the group should carry a first-aid kit and be familiar with basic first-aid.
6. Carry out your trash and trash left behind by others.
7. On completion of the hike, fill out a hike award application and submit this with the Den Hike Report to your local High Adventure representative for approval.

CUB RANGER



Fig. 5-3
CUB RANGER
2" x 2"

This award is designed to supplement the cubbing program, especially in the summer months. Cubs, Webelos, Den Chiefs and registered adult scouters may earn this award by completing all the requirements.

This award cannot be earned in conjunction with any other High Adventure Award, but you are encouraged to use this award as part of advancement requirements.

Requirements:

1. Comply with all Council General Requirements and General Requirements of this TREK AID.
2. Visit a National, State, County, City or Local Park that has a "Ranger" type program relating to the outdoors. Example: Guided nature hikes, environmental and animal programs, etc.
3. Participate in the "ranger" program, take notes, and complete a Den Report.
4. A boy from the Den will present this report at the next Pack Meeting. If possible, the award should be presented to the Den during the Pack Meeting.

5. Awards may be displayed on the right pocket (temporary patch location) of the Cub and Webelos uniform. Den Chiefs and Scouters should display these awards on a "brag sheet" or backpack.

TROPHY SKIN

Use the trophy skin to display extra badges you have earned and decorate your room.

MATERIALS

- Two 18" sticks or dowels
- Two 15" sticks or dowels
- Four 12" pieces and one 90" piece of hemp twine
- Four 12" pieces of bell wire
- One 12" x 15" piece of thin vinyl

PROCEDURE

1. Bend the four sticks or dowels together with bell wire to form a rectangle. Be sure to make these joints as rigid and tight as possible.

Cut the piece of vinyl in the shape of a skin, following the pattern in the picture. Punch holes around the edges as indicated.

3. Tie the four corners in place with the four 12" pieces of twine. Then lace around the skin with the 90" piece of twine.
4. Your badges may be sewn, stapled, or glued to the skin.

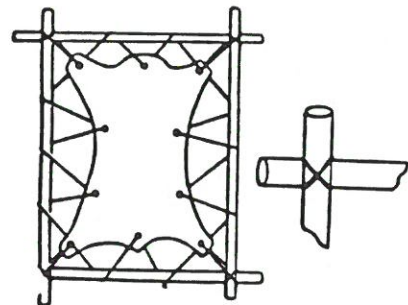

SLIDE OF THE MONTH:

Acorn

BY BILL FLEMING

Here's a slide to carve that won't drive you nuts.



THIS NECKERCHIEF SLIDE is easy to carve and uses the natural grain of the wood for a realistic look. It's also quick to complete, because there's no need for detailed painting.

- You'll need:
- 3/4 by 1 1/2 by 3 inch block of butternut wood, pine or basswood
- 1 1/2 by 1 inch block of soft wood for the loop

- coping or band saw
- sharp knife, wood glue, sandpaper, varnish and floor wax.

1. Draw the acorn pattern on the face of the large block of wood, as shown in figure 1. Butternut wood has an attractive natural grain, but soft woods like pine and basswood also work well. After tracing the pattern, cut off the excess wood with a coping or band saw.
2. Cut out the loop in your second block of wood (figure 3). Attach it to the back of the acorn block with wood glue; clamp the loop in place to let dry overnight. By doing this step now, you will have something to hold onto while whittling.
3. With a sharp knife, whittle the profile

of the acorn as shown in figure 2. Round off the nut, shell and stem of the acorn. Next, take your knife and make small "V" cuts in the shell to simulate an acorn shell's rough texture.

4. Using medium sandpaper, sand the entire acorn smooth. Finish it off with a fine sandpaper.

5. Give your carving a good coat of satin-finish, polyurethane varnish and let it dry. Sand it smooth again and give it one more coat of varnish. When this coat has dried, rub off the shine with steel wool and give the acorn a coat of paste floor wax. Buff it well with a soft cloth for a smooth, shiny finish, and you're done.

Easy as acorns ♣

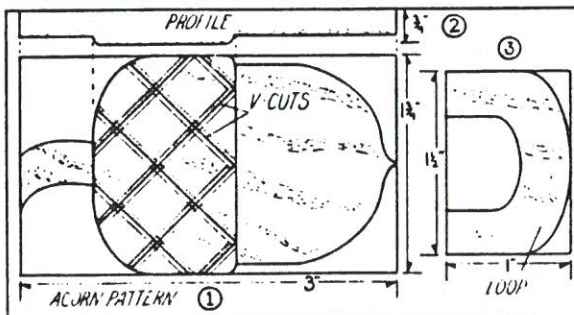

THE SHAWNEE MOCCASIN

HOW TO MAKE YOUR OWN PAIR

First make the pattern.



1. Get a piece of paper that is about two feet square. Put your right foot in the middle of the paper and trace around it.

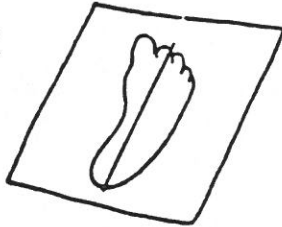

2. Draw a heel-toe line. It should go through the middle of the widest part of your foot.

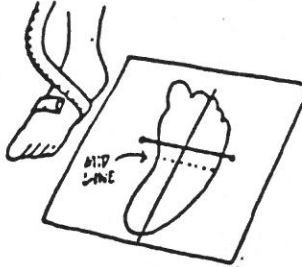

3. Measure around your arch. Draw a line that length as shown. It should be drawn just above the middle of the heel-toe line. The heel-toe line should run through the middle of the arch measurement.

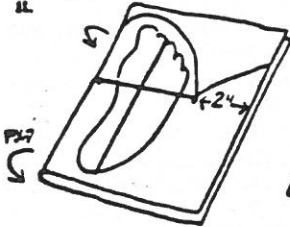

4. Draw a pattern around your foot as shown. It should extend one-half inch on each end with an extra two inches for the cuff, the pointed part.

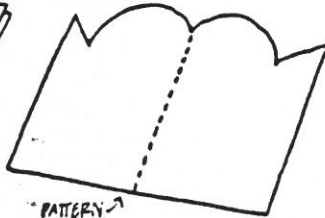

5. Fold the paper with your marks facing out. Then cut out the pattern on all the lines you have drawn except the fold line.

Use the pattern to cut moccasins from the material you are going to use. The same pattern works for both feet.

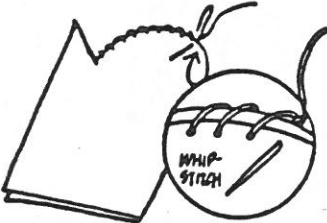

6. Fold the material along the fold line, with the right sides inside. Sew with a whip-stitch as shown.

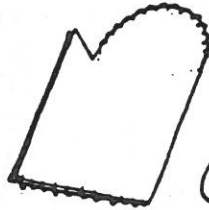

7. Sew up the back seam. Now turn the moccasins right side out. Fold down the cuffs. Try them on.



PAGE 6 - JULY - BUCKSKIN PIONEERS AQUANAUT/FORESTER

FOURTH OF JULY EAGLE

MATERIALS

Paper plates
Ruler
3" Jar lid
Markers or crayons
Pencil
Scissors

DIRECTIONS

1. In the center on the back of a paper plate, place a jar lid about 3" in diameter. Trace around it.
2. Draw the head of an eagle inside the circle with the neck on the edge as shown.
3. Use a ruler to draw the straight lines as shown.
4. Cut around the eagle's head and on the straight lines.
5. Color the back bottom half of the plate with designs in red, white, and blue.
6. Turn the plate over, and color the front half of the plate with designs.
7. Bend the sides of the paper plate around, and hook the slits over each other so that the ends form wings.
8. Place the eagle in the center of your Fourth of July picnic table.



INDIAN DRUM

This authentic looking and sounding drum can be made from the following:

No. 10 tin can Leather or plastic lacing
Rawhide or canvas Acrylic paint, brush

1. Cut both ends from the tin can.
2. Cut two circles of rawhide or canvas, about 4 inches larger in diameter than the can. This will leave a 2-inch border for lacing.
3. Punch holes about 1/4-inch from edge all around the rawhide circles, as shown.
4. Lace top and bottom to drum with leather or plastic lacing. Stretch tight.
5. Paint drum with Indian symbols.
6. Make a drumstick by covering a wad of cotton with a piece of rawhide and binding it to a stick or dowel with a sturdy string.



INDIAN DRUM

PAGE 7 - JULY - BUCKSKIN PIONEERS AQUANAUT/FORESTER

NOISEMAKER

MATERIALS

Empty 1/2 pint milk carton
Several Small Stones or Beans
Glue
Newspaper
Tempera Paint
Small Dowel
Construction Paper

DIRECTIONS

1. Place several small stones or beans inside a half-pint milk carton.
2. Cover the milk carton with glue and a layer of newspaper.
3. When dry, paint with blue tempera paint.
4. Into the bottom of the carton push and glue in a red dowel rod for the handle.
5. Use paper stars and stripes to decorate.
6. Curl 1/2 inch-wide strips of red and white construction paper and glue to the top and bottom of the carton.



DANGLE NECKERCHIEF SLIDES

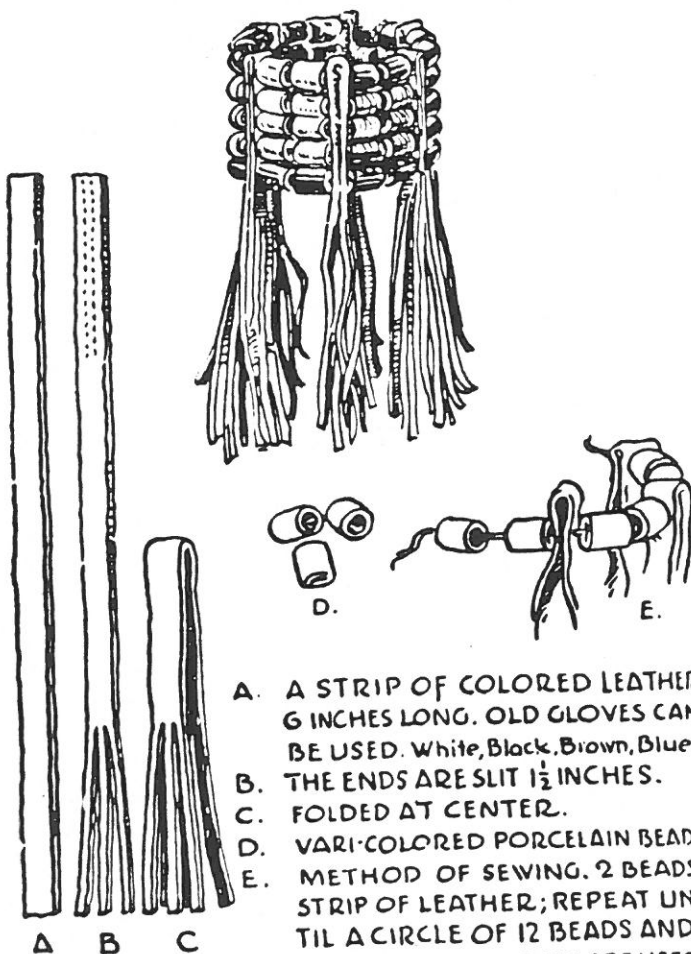

- A. A STRIP OF COLORED LEATHER 6 INCHES LONG. OLD GLOVES CAN BE USED. White, Black, Brown, Blue.
- B. THE ENDS ARE SLIT 1 1/2 INCHES.
- C. FOLDED AT CENTER.
- D. VARI-COLORED PORCELAIN BEADS
- E. METHOD OF SEWING. 2 BEADS, STRIP OF LEATHER; REPEAT UNTIL A CIRCLE OF 12 BEADS AND 6 PIECES OF LEATHER ARE USED.



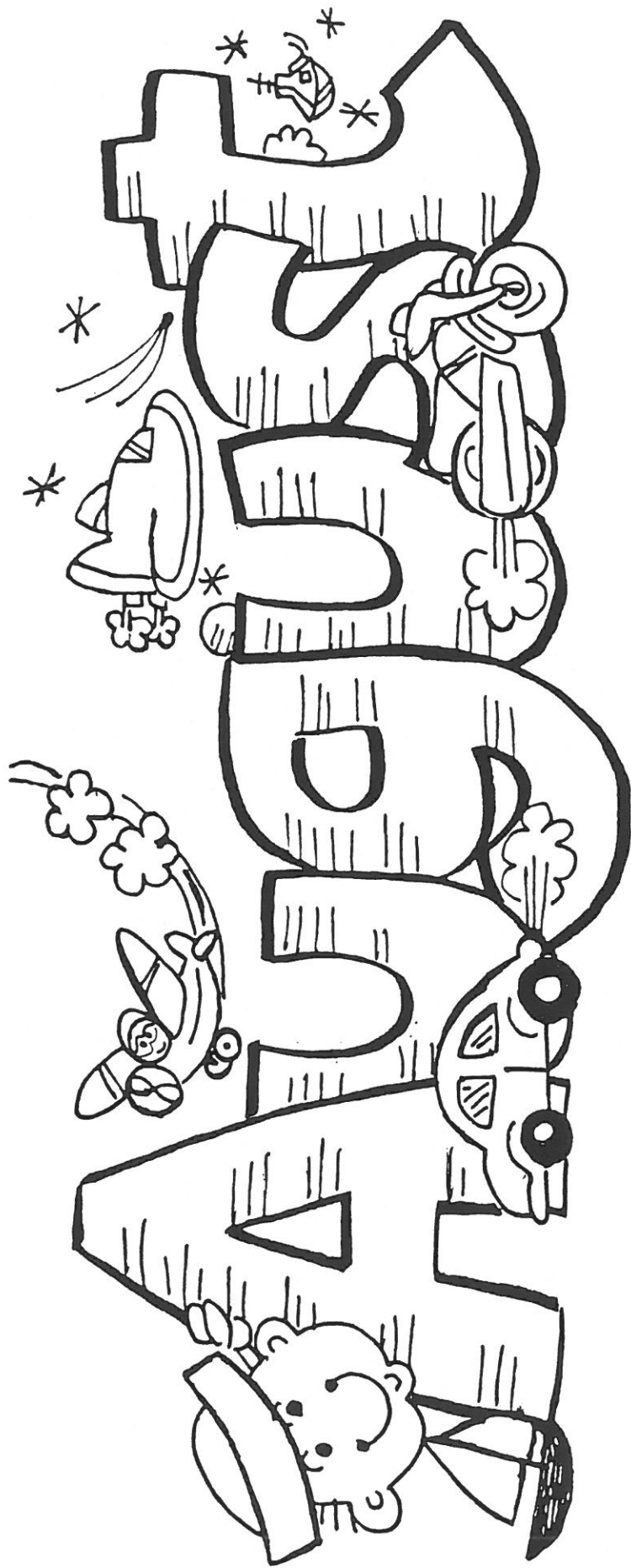

**Harbors, Stations, an Airports
Traveler/Artist**

**AUGUST
HARBORS, STATIONS, AN AIRPORTS
TRAVELER/ARTIST**

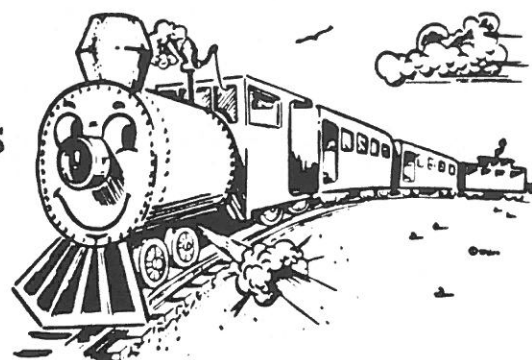

SONGS

THE BUS SONG

Tune: Mulberry Bush

The wheels on the bus go
round and round Round
and round, round and
round The wheels on the
bus go round and round
All trough the town

2. The people on the bus
go up and down,(etc.)

3. The driver on the bus
says" Move on back", (etc.)

4. The money on the bus
goes clink, clink, clink,
(etc.)

5. The horn on the bus
goes honk, honk, honk,
(etc.)

6. The wipers on the
bus go swish, swish,
swish, (etc.)

7. The babies on the bus
go waugh, waugh, waugh,
(etc.)

8. The mummies on the
bus go shh, shh, shh, shh,
(etc.)

DOWN BY THE STATION

Down by the station early
in the morning
See the little puffer bellies
all in a row
See the engine driver pull
the little handle
Puff! Puff! Toot! Toot! off
they go

TRAVELING

Tune: Home on the Range

Oh, give me a train, or a
boat or a plane
That will carry us Cubs
far away
To Paris or Rome, let us
wander or roam
And find new things to do
everyday

Relax on the trail--
Float over the waves all
day
Or glide thru the clouds
Far over the crowds
But be home before five
everyday

On a broomstick we'll ride
In a rowboat we'll glide
Take a trip to the moon in
a rocket
And our trip will be fun
But it soon will be done If

**PAGE 2 AUGUST - HARBORS, STATIONS, AN AIRPORTS
TRAVELER/ARTIST**

we happen to hit an air pocket

**THINGS THAT GO
Tune: Row, Row, Row
Your Boat**

Ride, ride ride your bike
Pedal for goodness sake
Up and down, up and
down
How your legs do ache

Ride, ride, ride the bus
Ride it here and there
Seeing all the pretty sights
Without driving the car

Fly, Fly Fly a plane
It's really lots of fun
Gliding high up in the sky
Just see that setting sun.

**I'M A GREAT BIG GIANT
PLANE
Tune: Hush Little Baby**

I'm a great big giant plane
Master of the skies I reign:
I can Fly for many an
hour

I', a jet with lots of power
Zoom, zoom, zip, zip,
boom, boom, roar, roar
Repeat 3 more times
(zoom, zoom, etc)

**THE BACKYARD
RAILROAD COMPANY**

By STACY H. WOOD,
Field Commissioner,
Sivanoy Council.

A SOUND BARRIL FOR A
BOILER AND LARGE TINCANS
FOR FUNNELL, LAMPS AND
CYLINDERS. PAINTED BLACK
WHEN ASSEMBLED.

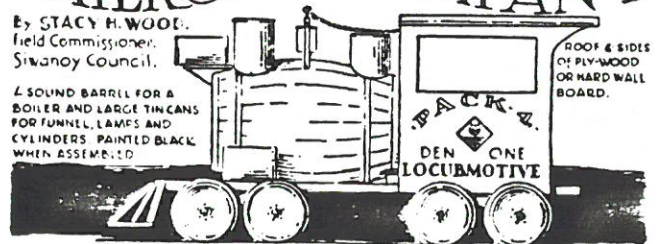

ROOF & SIDES
OF PLY-WOOD
OR HARD WALL
BOARD.

ABOUT 7 OR EIGHT FEET LONG OVER ALL. TRACK TO BE OF ROUGH 1-2"
SLOTLING STRIPS LAID ON TILES ABOUT 2 FEET APART. WIDTH WILL BE
GOVERNED BY LENGTH OF WHEEL AXLES.



WHEEL-TRUCK.
MADE 2x4 LUMBER. NAIL
OR SCREW METAL AXLES TO
CROSS PARS. BOLT TRUCK TO
CHASSIS WITH 6" BOLT, 2
HEAVY WASHERS BETWEEN.

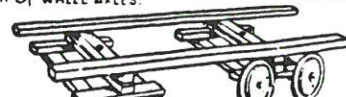

CHASSIS FOR ALL ROLLING STOCK.

WHEELS OF COURSE ARE VERY
IMPORTANT. RUBBER-TIRED AND
TAKEN FROM TWO SMALL WAGONS.
A CIRCULAR DISK OF SHEET-IRON AN
INCH LARGER THAN DIAMETER OF
WHEEL, IS CUT AND BOLTED TO INSIDE
OF WHEEL FOR A FLANGE.



The Back Yard Railroad is a Dad
and Cub project. It will require
a very slight expenditure -
principally for lumber for
rails. Wheels can be pur-
chased or taken from small
wagons and flanged in the
home work-shop or by a tin-
smith.

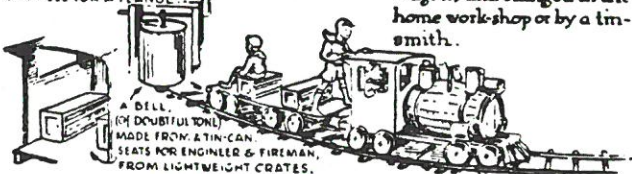

A BELL
(OF DOUBTFUL TONE)
MADE FROM A TIN-CAN.
SEATS FOR ENGINEER & FIREMAN,
FROM LIGHTWEIGHT CRATES.



PAGE 3 AUGUST- HARBORS, STATIONS, AN AIRPORTS TRAVELER/ARTIST

SPEEDY

This is an original cross between a French Mirage Jet and a Bat. We call it 'Speedy' because it has turned out to be a fast and cunning flyer, always trying out some new trick. This model is an easy one to fold and you can easily make lots of them at once. Why not assemble a whole squadron, give them names or numbers and fly them all together?

- 1 Take a piece of paper $20 \times 30\text{cm}$ ($8 \times 12\text{in}$) and fold the two opposite corners together.
- 2 Fold up the bottom edge, exactly half the distance of 'a'.
- 3 Fold the paper in half along the dotted line.

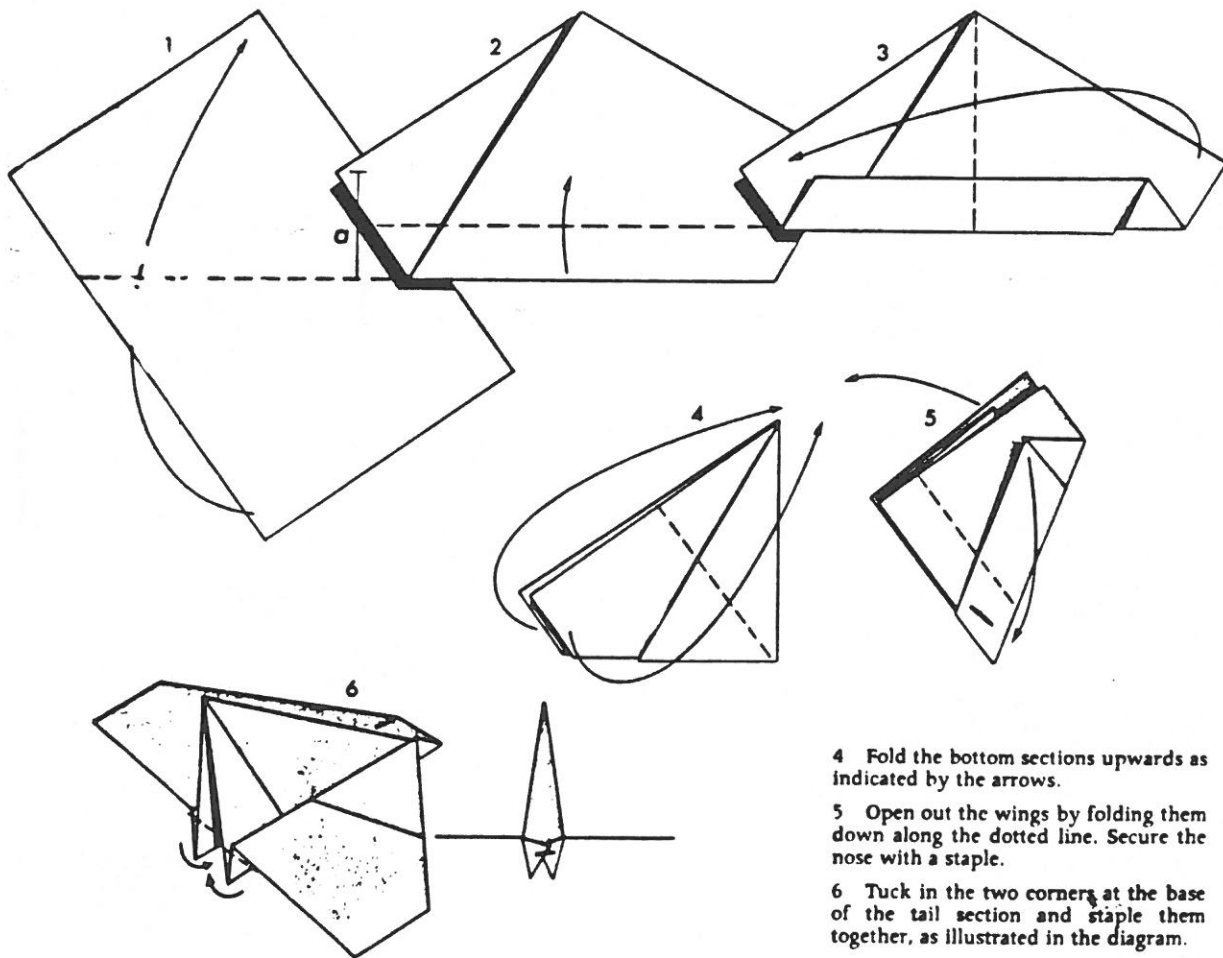

- 4 Fold the bottom sections upwards as indicated by the arrows.
- 5 Open out the wings by folding them down along the dotted line. Secure the nose with a staple.
- 6 Tuck in the two corners at the base of the tail section and staple them together, as illustrated in the diagram.

PAGE 4 AUGUST- HARBORS, STATIONS, AN AIRPORTS TRAVELER/ARTIST

EAGLE

This king of the sky does not require the Basic Crane method – the majestic creature has its own folding method. The eagle glides well, expertly making use of currents of warm air to soar high in the sky. The wings hardly ever have to move. From a great height the eagle can spot a mouse amongst the grass with its extraordinarily sharp eyes. The eagle is a symbol of freedom and greatness and features in the coats of arms of many countries. Like his real life counterpart, this paper Eagle possesses the same ability to hover, so long as it finds some currents of warm air to provide the lift.

- 1 Take a sheet of paper 20 × 20cm (8 × 8in) and fold it in half diagonally.
- 2 Fold the triangle along the dotted line, as directed by the arrow.
- 3 Fold back the top layer following the dotted line.
- 4 Fold the whole model in half.
- 5 Fold the wings up along the dotted lines, one to either side and tuck in the tail with an inverted fold.

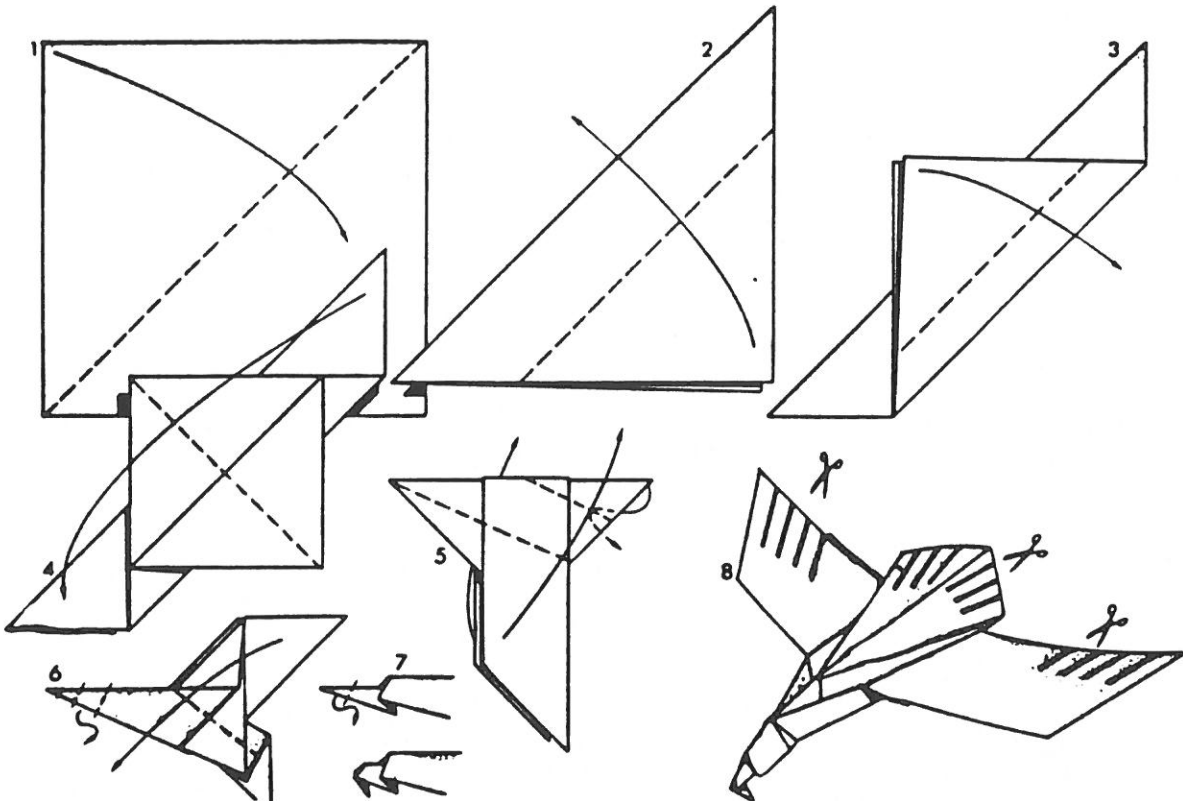

6 Make three good creases in the nose and then two inverted folds make the hooked beak. Bend the wings into the flying position by folding them down the dotted line.

7 These detailed diagrams show the nose and beak folds more clearly.

8 As a finishing touch, make slits in the wings and tail to represent feathers – this may even improve its flight. Now the eagle can go out and prey on the neighborhood.



**Explore your Neighborhood
Communicator/Scientist**

**SEPTEMBER
EXPLORE YOUR NEIGHBORHOOD
COMMUNICATOR/SCIENTIST**



SONGS

**WALKING IN MY
NEIGHBORHOOD**

**Tune: I've Been Working
on the Railroad**

BY: Bobbie Hoffman(OBC)

I've been walking in my
neighborhood
To see what I can see
I've been walking in my
neighborhood
My Cub Scout Den and me
There's a lot in my own
neighborhood
That I have never seen

I like walking in my
neighborhood
My Cub Scout den and me

All Kinds of houses
All kinds of Churches
There's so much to seeeee

All kinds of people
All kinds of street signs
There's so much to see

I like walking in my
neighborhood
I like walking in my
neighborhood
I like walking in my
neighborhooodooooood
My Cub Scout den and me.

LET'S GO ON A HIKE

Tune: Let's Go Fly a Kite

BY: Bobbie Hoffman(OBC)

Let's go on a hike
Maybe even ride our bikes
Let's go on a hike
And go exploring
We can go almost
anywhere
There's a lot to see out
there
Oh Let's go on a hike.

Communicator:

Learn sign language (contact profes-
sionals for demonstration).

Develop and use secret codes with
recognition for code that takes
longest to break.

Visit centers of communications like:
newspaper, radio, T.V. station (check
local colleges.)



PAGE 2 - SEPTEMBER

EXPLORE YOUR NEIGHBORHOOD

COMMUNICATOR/SCIENTIST

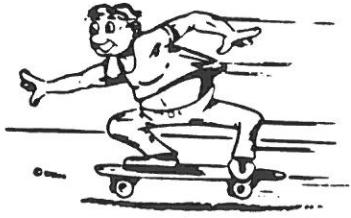

A BELT WALLET

Your loose change, bills, and other odds and ends won't get lost if you use a belt wallet. These wallets fit securely

on a belt and are easy to make from the following:

- 4-by-12-inch scrap of leather or vinyl
- 1 yard of 1/2-inch leather or plastic lacing
- Rotary leather punch
- Awl
- Knife or razor blade to cut leather
- Leather tools as desired
- Rubber cement
- Cardboard or tracing paper pattern

1. Enlarge either of the patterns to the size indicated. (If you wish to make larger wallets, you will need a larger piece of leather and more lacing.) Be sure to space the holes evenly.
2. Cut the leather to size. Use paper clips to hold the pattern in position while cutting the leather and marking the hole centers with the awl.
3. Tool the leather in an original design or use initials.
4. Apply rubber cement along the edges where the holes will be placed. Lightly hammer the seams together, rough side inside. Punch holes with 1/2-inch punch, going through all thicknesses.
5. Cut one end of the lacing to a sharp point. For pattern "A," use an in-and-out stitch, tucking the ends under. Add "Flap Strap" as shown in the pattern.

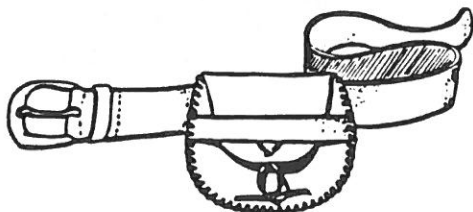

6. Use the rest of the lacing to make a decorative finish to the flap.

POMONA VALLEY HISTORIC SITES

This award is designed to promote awareness of local history and the places in Old Baldy Council where it occurred, and to give recognition to participants who complete the requirements. The award may be earned as a Den or Pack activity. Only registered Cub Scouts, Adult Leaders, or Den Chiefs may qualify for this award.

» Requirements:

1. Each participant shall prepare a list containing a minimum of six historic sites located within the boundaries of Old Baldy Council.
2. Visit any three of the historic sites on your list. (This will require you to file a B.S.A. Tour Permit)
3. On a separate outing, do a hike of at least two (2) miles - starting at one historic site and ending at another historic site. The hike may be done on bicycle or on foot. (This will require another B.S.A. Tour Permit)
4. Each participant shall write a one paragraph report for each historic site visited.
5. All requirements must be completed within a thirty (30) day period.



Fig. 3-2
HISTORIC SITES
3" x 3"

NOTES:

1. Contact Old Baldy Council H.A.T. member or Pomona Historical Society at (714) 623-2198 for suggestions on appropriate historical sites to visit.
2. Obtain Old Baldy Council "Pomona Valley Historic sites" pamphlet which contains a map containing suggested hikes and mileage.

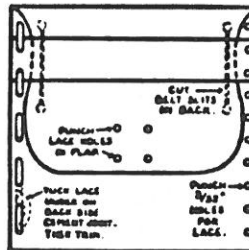

PATTERN A

BELT WALLET

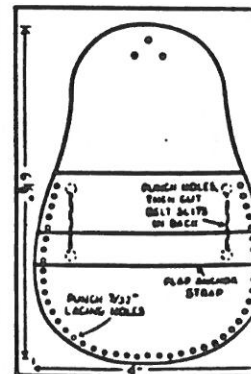

PATTERN B

For pattern "B," begin lacing at the top of either side using the whip stitch described earlier in this chapter. Add the "Flap Strap" to the front over the six through eighth holes.

PAGE 3 - SEPTEMBER
EXPLORE YOUR NEIGHBORHOOD
COMMUNICATOR/SCIENTIST

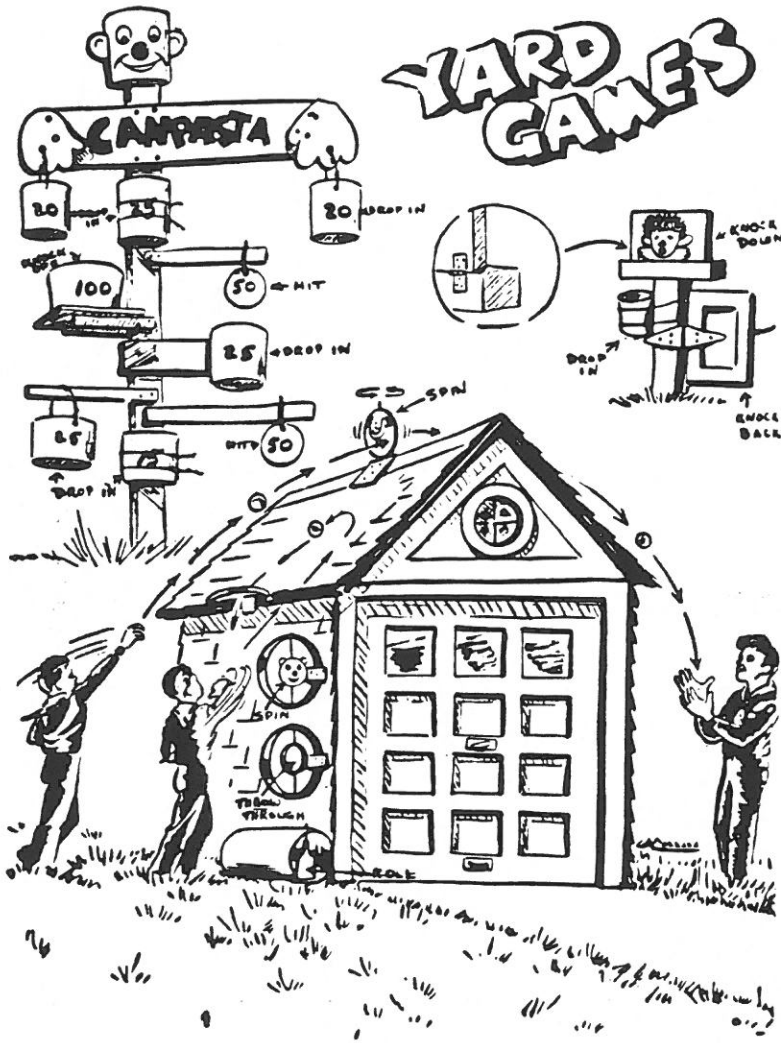

Basic Body

All of the finger puppets have the same basic body. To make the body, first cut the body shape from your fabric. Fold about $\frac{1}{4}$ inch along the bottom straight edge to the wrong side, and hem with a line of machine stitching. Next, fold the body piece in half, with the right sides facing, so that the curved edges meet, and stitch around from the bottom up the center back and around the curved edge. Turn the body right side out and then finish with animal features.

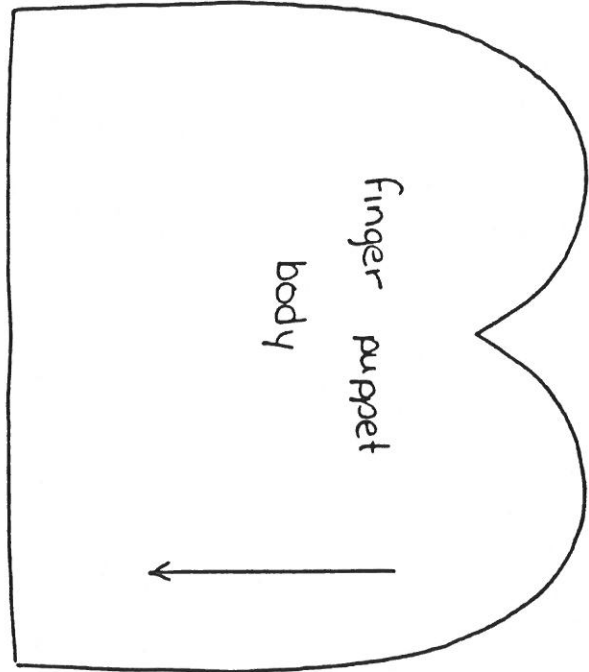

Rabbit

Materials: 5" x 7" tan fur fabric
scraps of pink, black, white, orange, and green felt

Before making the body, prepare the ears. To make an ear, place two pieces together, with the right sides facing, and stitch all around the curved edges, leaving the straight bottom open; then turn the ear right side out. Now make the body according to the instructions on page 10, leaving the top open. Insert the ears, facing front, into the opening. Flatten out the body so that the middle back seam is in the middle of the body. Stitch across the top of the body, catching the ears in the stitching. Turn. Glue the teeth, nose, and eyes in position on the face. Glue the greens of the carrot in position on the front of the body, and then the carrot on top of the greens.

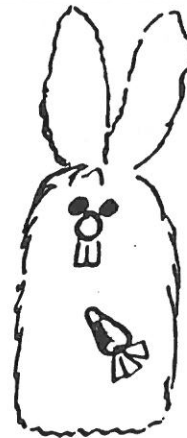

Bird

Materials: 4" x 5" yellow fur fabric
small yellow fluff feather
scraps of orange and black felt

Make the body according to the instructions on page 10, catching the feather in the stitching at the top of the head. Turn. To make the beak, stitch darts in either side and then glue the beak in the middle of the face. Glue the eyes in position above the beak.

Bear

Materials: 5" x 7" tan fur fabric
scraps of black, pink, brown, and red felt
tiny amount of polyester fibre stuffing

Make the body, following the instructions on page 10. Make the snout by using the circle technique, described on page 8, using very little stuffing and flattening it out between your fingers. Then stitch the snout in position on the face. Make the ears by gluing the sides together, with the *wrong* sides facing. Glue the ears in position on the sides of the head. Glue the nose and tongue to the snout, and the bow tie beneath it. Glue black pupils to brown eyes, and then the eyes to the face.

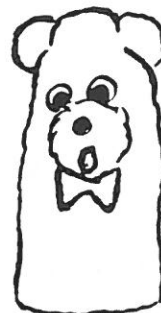

Monkey

Materials: 4" x 5" brown fur fabric
scraps of tan, black, yellow, and white felt

Make the body, following the instructions on page 10. Mark the mouth on the face with black thread. Glue the face to the front of the body piece. Glue the eyes and nose in position. Next, glue the ears in position on either side of the face. Make the banana by gluing the white piece in position on the body, with the yellow-peel piece in position beneath it. Then glue the paw in position over the peel.

Penguin

Materials: 4" x 5" black fur fabric
scrap of white fur fabric
scraps of yellow, black, and orange felt

Before making the body, glue the breast piece in position and topstitch all around the edge. Now make the body, following the instructions on page 10. Make the beak by stitching darts in either side and then gluing the beak in position in the middle of the face. Glue black pupils to yellow eyes, then the eyes to the face above the beak.

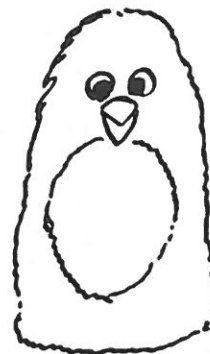

Owl

Materials: 4" x 5" grey fur fabric
scraps of red, grey, black, and orange felt

Make the body, following the instructions on page 10. To make the beak, stitch darts in either side and then glue the beak in position in the middle of the face. Glue the eyes in position on the face piece, and glue the face piece to the front of the body above the beak. Stitch darts in the wing pieces; then glue the wing pieces in position on the sides of the body.

PAGE 6 - SEPTEMBER
EXPLORE YOUR NEIGHBORHOOD
COMMUNICATOR/SCIENTIST

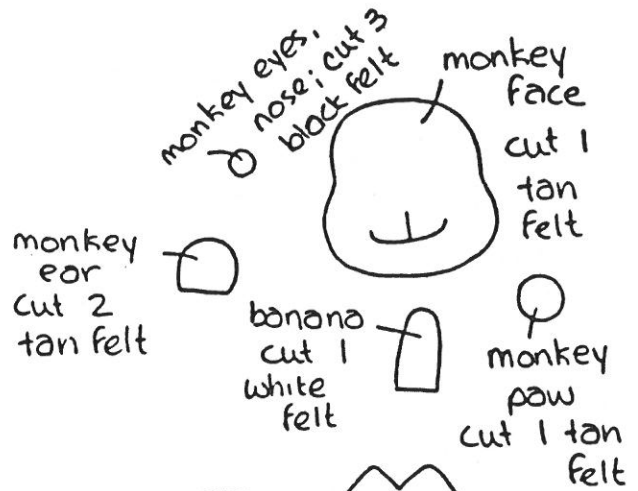
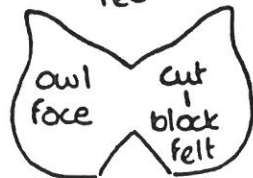
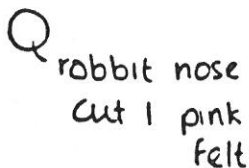
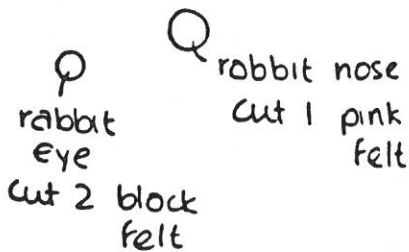
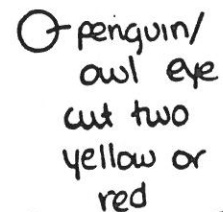
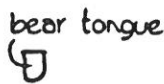
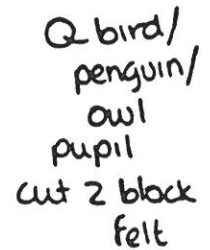
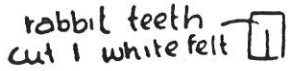
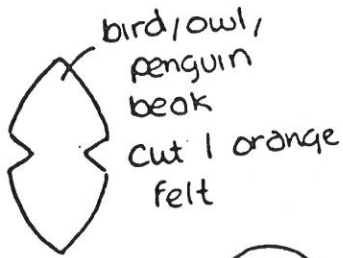

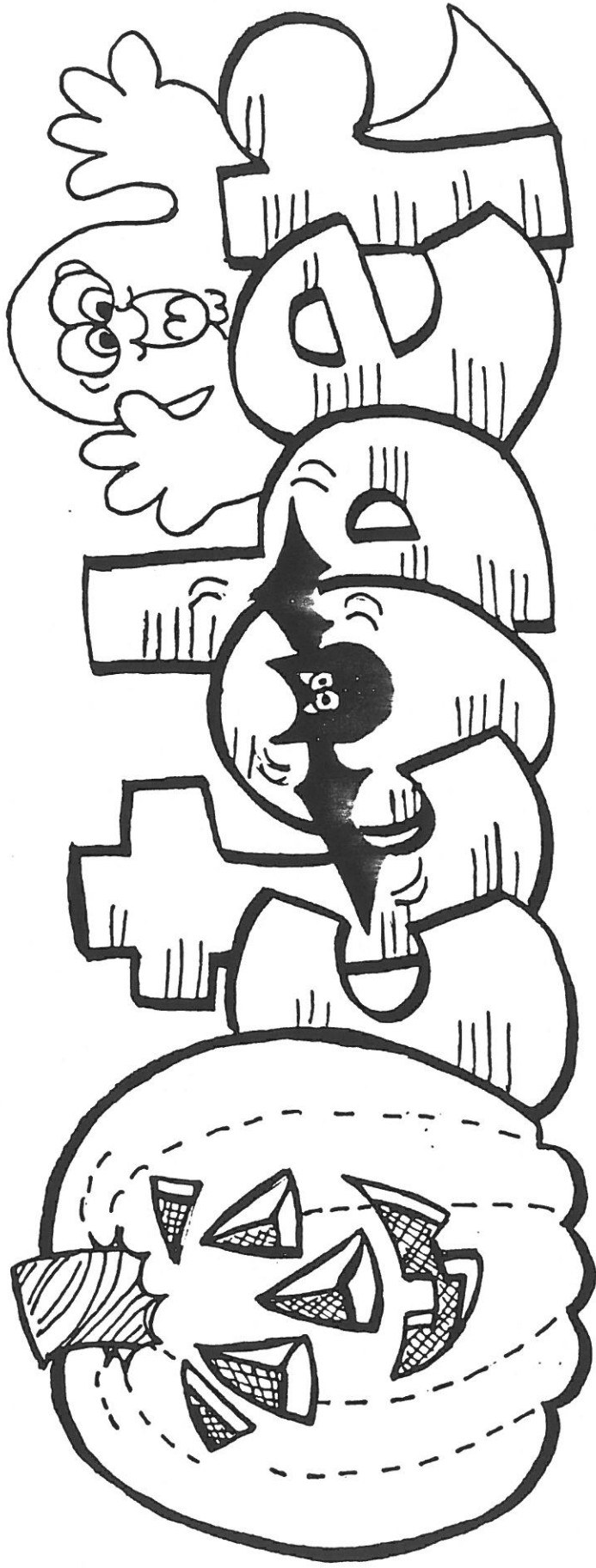

**Land of Make Believe
Fitness/Scientist**

**OCTOBER
LAND OF MAKE BELIEVE
FITNESS/SCIENTIST**

**SONGS
LET'S PRETEND
Tune: Are You Sleeping
BY: Karen Zuk (OBC)**

Let's pretend
Let's pretend
Let's Make Believe
Let's Make Believe
We'll use our Imagination
To make-up a situation
This is fun
This is fun

We can do it
We can do it
What we want
What we want
In the Land of Make
Believe
We can be what we want
to be
This is fun
This is fun

Imagination
Imagination
Will take us there
Will take us there
We, pretend, is the key
To anything, you see
It is fun
It is fun



**USE YOUR IMAGINATION
Tune: Clementine
BY: Karen Zuk(OBC)**

I'm an Astronaut, I'm a
Pirate
I'm a Buckskin Pioneer
Just use your imagination
In the land of make believe

I'm an Indian Chief, I'm a
cowboy
I'm an Alien from space
You can choose what you
want to be
In the land of make believe

I can ride in a space ship
On a boat or on a horse
You can choose how you
travel
In the land of make believe

Come with me and pretend
Play out all your
fantasies
You can use your
imagination
In the land of make believe

**JUST GUESS WHAT YOU
CAN BE**

**Tune: For He's a Jolly
Good Fellow
By: Bobbie Hoffman(OBC)**

If you use your

imagination
 If you use your
 imagination
 If you use your
 imagination
 Just guess what you can
 be

In the land of make believe
 In the land of make believe

Pirate or a Astronaut
 Knight in Shinning Armor
 Indian or a Cowboy In the
 land of make believe

SPOOLISHNESS

BY STACY HANCOCK, FIELD COMMISSIONER, SEWANOY COUNCIL, NEW JERSEY COUNTY, N.Y.

THE LATCH KEY OR GARAGE KEY WILL BE EASY TO FIND WITH THIS.

A LOG OF BARRELS FOR THE TOY FREIGHT TRAIN

A NECKLACE FOR THE INDIAN COSTUME.

A RAILROAD LANTERN FOR THE BOYS' SLIDES WITH BLACK LINES HANDLE MADE FROM WIDE PAPER CLIP

ABOUT WINDOW SHADE AND ELECTRIC LIGHT PULLS.

MATERIALS: KNIFE, QUICK DRYING ENAMEL (RED, BLUE, YELLOW, BLACK), SANDPAPER, SPOOLS AND BEADS. THE BEADS MUST BE LARGER THAN THE CENTER HOLE IN THE SPOOL.

BLOCK-PRINTING WITH SPOOLS

CUT ENDS OF SPOOLS WITH SHARP KNIFE IN DESIGNS AS SUGGESTED ABOVE. DIP IN TUBE PAINT OR ENAMEL THAT HAS BEEN SPREAD OUT ON PAPER. TAP COLORED SPOOL WITH BALL MANIPULATOR ON PIECE OF CLOTH THAT HAS BEEN MASTERCED DOWN WITH THUMB TACKS.

THE SPOOL MENAGERIE

SPOOLS, PIPE-CLEANERS, COLORED PAPER AND A LITTLE GLUE ARE ALL THAT YOU NEED FOR THE FUNNIEST ANIMALS AND BIRDS YOU'VE EVER SAW.

SLIDE OF THE MONTH:

Postage stamp

BY ROBERT SCHLEICHER

Use a decoupage technique to make an easy slide.

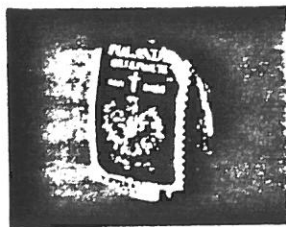

The first step is to select an attractive stamp to use. If your patrol has an animal mascot, you might want to choose one of the recently issued North American animal stamps.

I am of Polish descent, so I chose a commemorative stamp the United States Postal Service issued in 1966 to mark Poland's 1,000th anniversary.

You can mount your stamp on any neckerchief slide (wood, metal or plastic) with a flat surface. I made mine by screwing a brass eyebolt into a wooden cabinet knob.

Since the surface of the knob was not perfectly flat, I cut into the sides and tops of the stamp so it could lie flat on the curved knob.

Buy the kind of two-part resin used for decoupage projects from a craft store. Mix the resin and hardener in equal amounts. Use a Popsicle stick to coat the surface of the slide with the honey-like stuff and press the stamp in place.

THIS MONTH'S FEATURED slide combines two hobby interests: making neckerchief slides and stamp collecting.

If you are already into stamp collecting, you know there are colorful commemoratives that cover just about any topic—from animals to trees to cars, from famous people to exotic places.

Immediately apply a coat of the resin over the stamp. Let it dry for 48 hours and apply a coat of floor wax to protect the surface.

The finished slide is waterproof, so it should last a lifetime. You can use the same process to decorate magnets, buttons or even drawer and door handles.



You can make a slide out of a brass eyebolt and wooden cabinet knob.

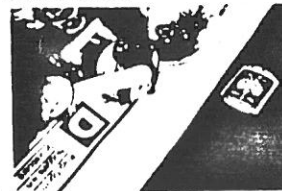

Use an ice cream stick to spread the first layer of resin over the slide.

BONECRAFT



USE A RAW, UNCOOKED BEEF BONE OBTAINED FROM THE BUTCHER. SEVERAL ARTICLES CAN BE MADE FROM ONE BONE.

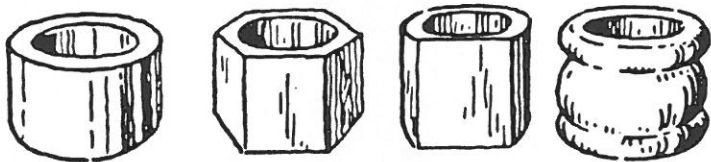

SOME SHAPES FOR NECKERCHIEF SLIDES.



SHW

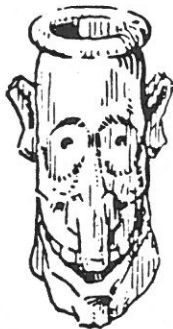

INNUMERABLE DESIGNS AND PATTERNS CAN BE CREATED OUT OF BONE. DO SIMPLE CARVING AT FIRST UNTIL THE MATERIAL BECOMES FAMILIAR.

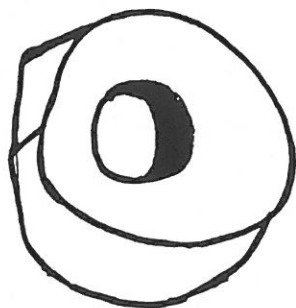

← Steak bone slide
 boil thoroughly and remove all meat and fat from round steak bone. Wash with soap and water. Let dry and varnish.

BUBBLING BOTTLES

A HOME MADE XYLOPHONE
 DESCRIBED BY MARGARET E. GILTNER,
 DEN MOTHER, PACK 156, TRIMONT, ILL.
 PICTURED BY STACY H. WOOD



EIGHT BOTTLES ARE NECESSARY TO START WITH. AFTER PRACTICE, MORE CAN BE ADDED, INCLUDING SHARPS AND FLATS TO FILL OUT THE NOTES OF THE SCALE.

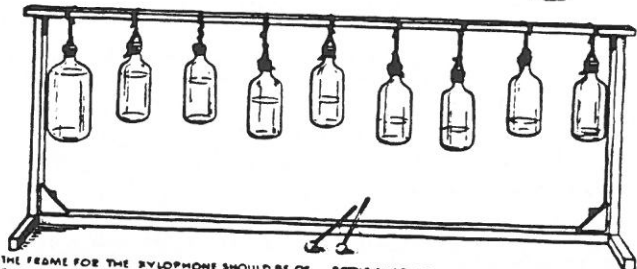

THE FRAME FOR THE XYLOPHONE SHOULD BE OF GOOD LUMBER, STRONGLY BRACED, AS THE BOTTLES ARE QUITE HEAVY WHEN FILLED AND TUNED. THE BOTTLES SHOULD BE ALL OF THE SAME KIND, IF POSSIBLE, WITH THE EXCEPTION OF THE FIRST ONE WHICH IS ONE QUART SIZE, THE OTHERS ARE PINTS. FILL THE BIG BOTTLE ALMOST FULL OF WATER AND TUNE IT TO THE KEY OF 'C' ON THE PIANO. THE OTHERS HAVE LESS AND LESS WATER AND THEY HAVE A HIGHER TONE IN THE SCALE. THE EXACT PITCH CAN BE OBTAINED BY ADDING OR SUBTRACTING A LITTLE WATER. CODEY: THE BOTTLES TIGHTLY SCREWED CAPS ARE BEST AND THEY WILL STAY IN TUNE.

MORE INSTRUMENTS FOR A DEN ORCHESTRA



MATERIALS: 2 PIE PLATES, 2 BOLTS (SPRONG RUBBER BALL); CUT BALL IN HALF; BOLT ON OUTSIDE OF PLATE.

A WOOD OR METAL CANDY BUCKET WITH LEATHER STRIPS TIGHTLY COVERED.

WOODEN CHOPPING BOWL WITH PRODOMETIC HANDLE; STRING SAME WAY AS VIOLIN.



**NOVEMBER
HEROES IN BOOKS
CRAFTSMAN/CITIZEN**

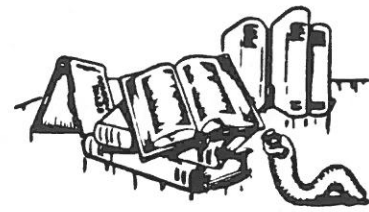

**SONGS
PECOS BILL
Tune: Down By the Station**

Pecos bill was raised by coyotes
Tamed a 10 foot rattlesnake
And used it for a whip
Caught a mountain lion
And rode it like a horse
Staked out New Mexico
And dug the Grand Canyon

**DANIEL BOONE
Tune: Yankee Doodle**

Daniel Boone was a good man
A hunter and trailmaker
Some say he was half man,
half horse
And the rest was alligator

He led the settlers over
The Allegheny Mountains
Into Kentucky
To find their new homes.



METAL TAPPING

ALL METAL SHOULD BE CUT FOR CUBS

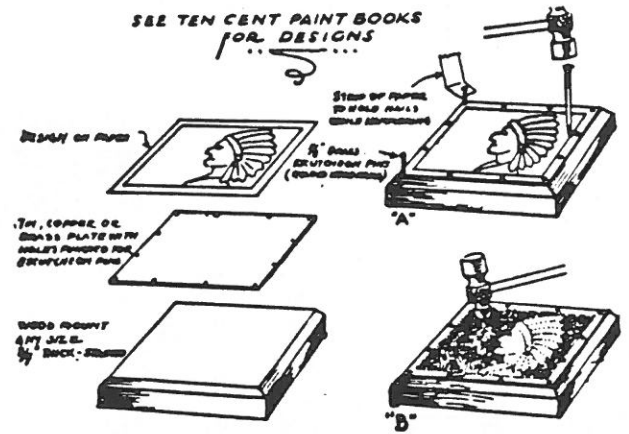

"A" SHOWING BLOCK AND METAL PLATE IN PLACE WITH PAPER DESIGN ALSO NAILED ON. ALL LINES OF DESIGN ARE STIPPLED WITH BLUNT POINTED NAIL TAPPED LIGHTLY WITH A TOY SIZE BALL-PEN HAMMER THRU PAPER. "B" WHEN ALL THE DESIGN IS STIPPLED, PAPER IS REMOVED AND ALL THE BACKGROUND AREA AROUND THE DESIGN IS TAPED WITH ROUND END OF HAMMER. TAP FROM THE OUTSIDE EDGE OF THE PLAQUE TOWARD THE DESIGN. THIS MAKES THE DESIGN APPEAR TO BE ENGRAVED.

BUILDING A DEN DEN

BY STACY H. WOOD
FIELD COMMISSIONER
SHERMAN COUNTY, MISSOURI
A BACKYARD PROJECT FOR CUBS AND CUBMERS, DINKY AND DINKY DADS

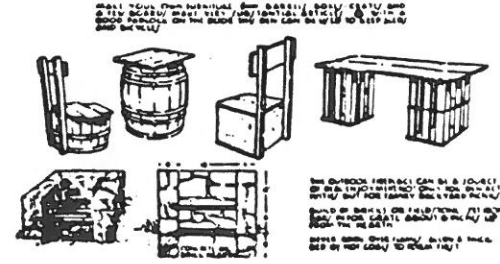
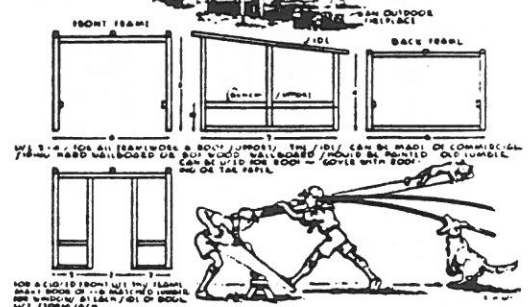

THE OUTDOOR FURNACE CAN BE A TABLE OR BENCH OR CHAIR. USE 1 1/2" THICK PLANKS FOR SIDING AND TRUSSING. A 1/2" BOARD OF 1 1/2" THICK FOR TOP. USE 1 1/2" THICK PLANKS FOR SIDING AND TRUSSING. A 1/2" BOARD OF 1 1/2" THICK FOR TOP.

PAGE 2 - NOVEMBER - HEROES IN BOOKS CRAFTSMAN/CITIZEN

WEBELOS

FLAG COURTESY KIT

Teach flag courtesy in the Webelos den. Build and use this kit as an aid to teaching and testing flag courtesy.

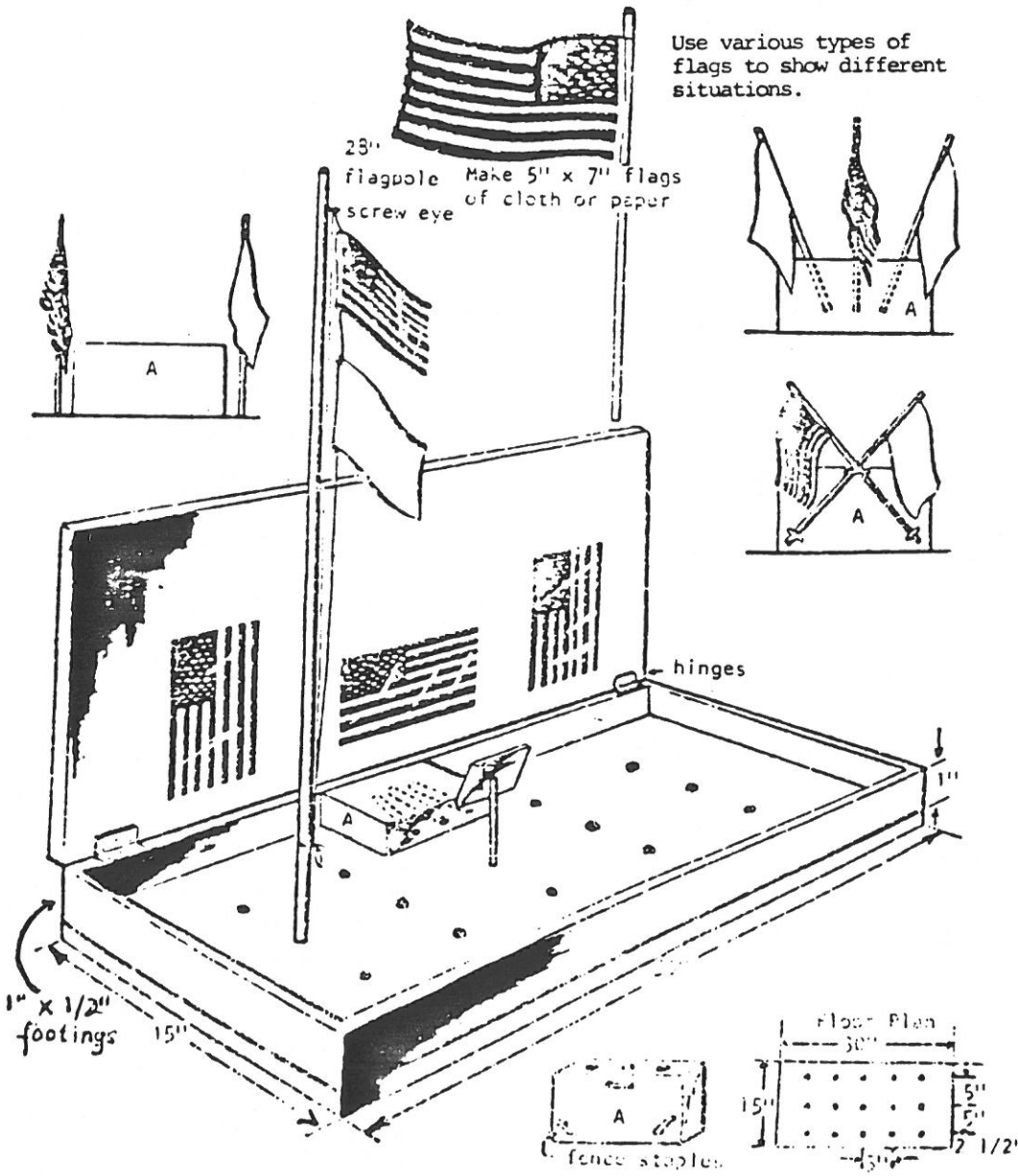

BACKYARD FURNITURE



BARREL CHAIR... PAD SEAT WITH PAPER AND COTTON,
COVER WITH CANVAS OR OIL-CLOTH



WATER & FOOD DUSTY CUP IN CON-
... SET IN A MOLD MADE FROM
A CHLORIDE-BOX & A KETTLE. USE 3 PARTS SAND



APPLE-BOX & ORANGE CRATE

GARDEN CHAIR

...THE OUTDOOR FIRE-PLACE IS A POPULAR ADDITION
TO ANY HOME. DON'T BUILD GRATE
TOO HIGH ABOVE FIRE.

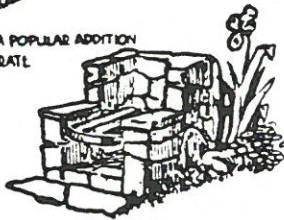

BARREL-
KENNEL... PAISE UP OFF OF GROUND ON A
BASE MADE OF 2x4s.

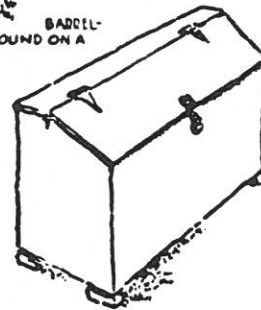

A CHEST IN WHICH TO STORE THE BACKYARD
GAMES. BUILD ON A FRONT 2x4 FRAME.

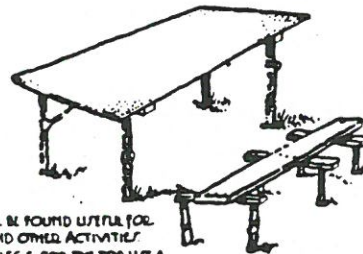

A PICNIC TABLE WILL BE FOUND USEFUL FOR
GAMES, PIC-NICS AND OTHER ACTIVITIES.
BUILD ON RUSTIC LEGS. FOR THE TOP USE A
PIECE OF COMPOSITION WALL-BOARD

LEATHER KEYCHAIN

This handy, easy-to-make item is a good gift for parent.
The following are needed:

- 1 1/4-by-4-inch leather
- Beaded key chain
- Leather tools

1. Select a design or set of initials which will fit on the piece of leather.
2. Punch a hole near the top of the leather, large enough for the key chain to slip through easily.
3. Follow the instructions above for leather tooling & imprint your design on the leather.

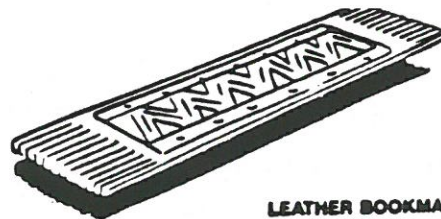

LEATHER BOOKMARK

LEATHER BOOKMARK

For this project, you will need the following:

- 3/4-by-8-inch leather
- Leather tools

1. Select a design or monogram which will fit on the piece of leather.
2. Follow the instructions above for leather tooling, imprint design on leather.
3. Bottom of bookmark can be cut into a fringe, desired.

PAGE 4 - NOVEMBER - HEROES IN BOOKS CRAFTSMAN/CITIZEN

ABRAHAM LINCOLN'S BIRTHDAY

PRETZEL LOG CABIN

MATERIAL LIST:

- Bag of fat pretzels about 7" long
- A sheet of green construction paper
- A sheet of brown construction paper

STORY BEFORE MAKING CRAFT

(Go to the library to get more information)
Abraham Lincoln was born February 12, 1809, in Hodgenville, Kentucky. His birthplace was a 16 x 18 foot log cabin with one window and a dirt floor. He was the 16th president of the United States.

It was necessary for people to cooperate 200 years ago, working together to build houses and barns. Since the main tools available were hatchets, saws, and hammers, everyone had to pitch in and help his neighbor build the log cabin structures that made up the pioneer farm.

TO MAKE THE CRAFT

Divide the pretzels as evenly as possible among the boys. Have them lay the sheet of green construction paper on the table to be used as the green grass where they will build the cabin. They can then start building the cabin by laying the pretzels in a crisscross fashion to form a square cabin. When complete, fold the brown square of construction paper in half to make a roof for the cabin.
If the pretzels are not glued together, the boys can dismantle the log cabin for snack time.

POINT OUT

The chinks or spaces between the logs were filled with clay from the river bank, mixed with straw or dried grasses to keep the cold out. They also covered their windows with oiled paper that let the light in, and used shutters when they wanted to close the windows tightly.

POTATO TURKEY

MATERIALS

- Regular or sweet potato
- Poster board or lightweight cardboard
- Crayons or poster paints
- Knife
- Empty paper towel roll

DIRECTIONS

1. Cut a large fan-type tail out of light cardboard or heavy paper.
2. Color or paint brightly colored feathers on the tail before attaching it.
3. Cut a slit in the back of your potato about halfway through.
4. Gently slide the tail into place.
5. Cut a head and neck section. Be sure to leave a tab to insert these pieces into the potato. Color or paint the pieces before attaching them. Use the point of your knife to stick into the potato to make slits.
6. Cut two wings for your turkey and color or paint them to look like bright feathers. Leave tabs to insert into the sides of the potato. Make slits with the point of your knife the same way you did for the head.
7. You can make a stand for your turkey by cutting a 2-inch section from an empty paper towel roll. This can be painted in a bright color or design.
8. Potato turkeys last quite some time, so they can be made ahead of time for favors or table decorations.

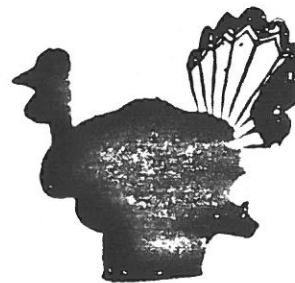
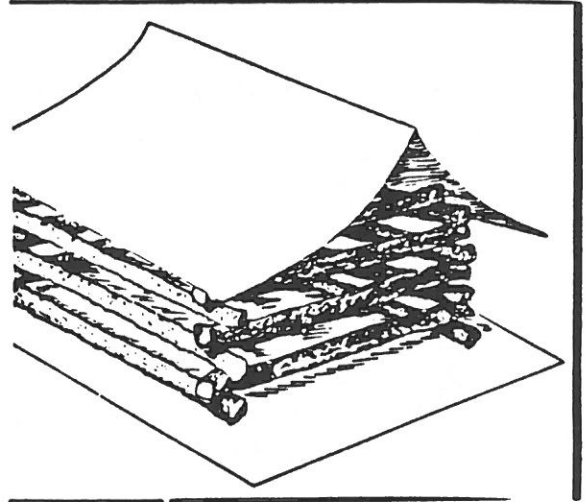

**SUNSET DISTRICT
CUB SCOUT ROUNDTABLE**

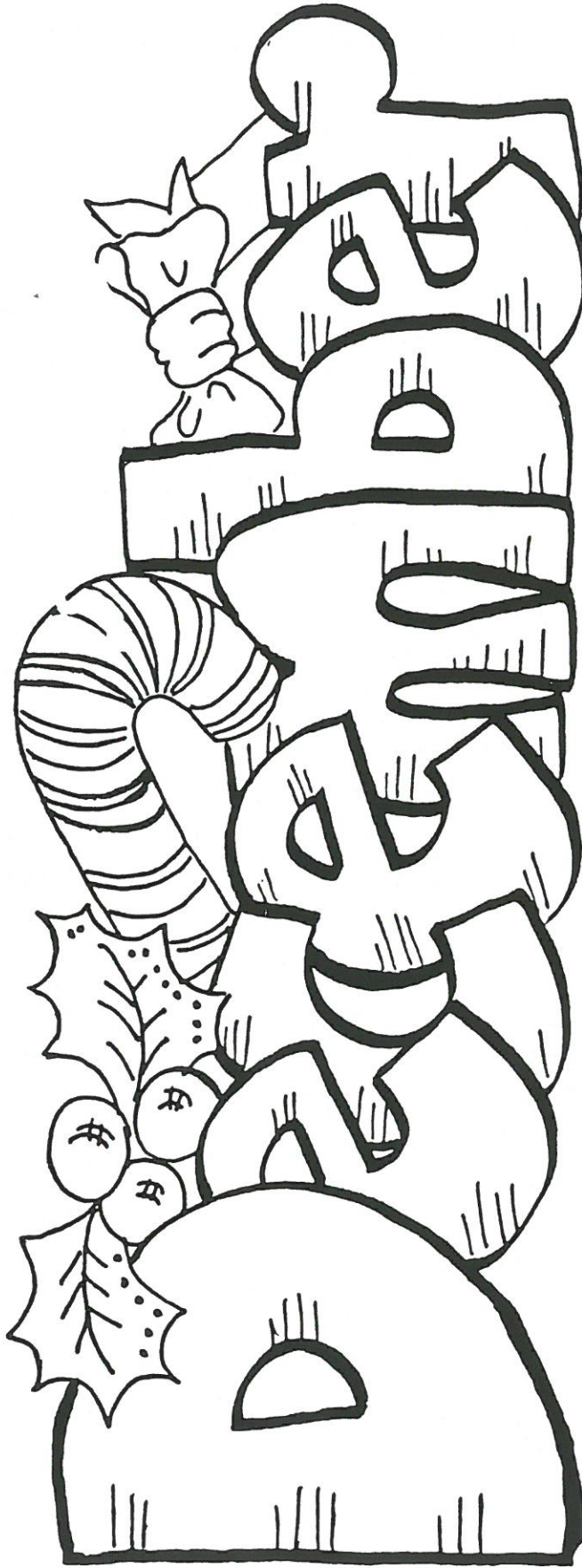

**Giving Gifts
Craftsman/Citizen**

BOBBIE HOFFMAN-COMMISSIONER	599-0514
FRED MOORE-FAST START	624-9203
NORMA BERGMAN	629-8978
JIMMY RAMIREZ	620-5024
BRIAN AND KAREN ZUK	598-8772
DOUG KROLL	624-0405
RICK AND NANCY SWEENEY	598-8213

**DECEMBER
GIVING GIFTS
CRAFTSMAN/CITIZEN**

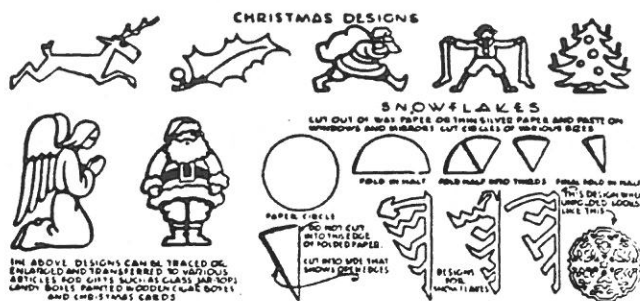

**SONGS
MUST BE SANTA**

Who's got a beard that's
long and white?
Santa's got a beard that's
long and white
Who comes around on the
special night?
Santa comes around on the
special night.
Special night, beard that's
white
Must be Santa, Santa Claus

Who's got boots and a suite
of red?
Santa's got boots and a suit
of red.
Who wears a long cap on
his head?
Santa wears a long cap on
his head.
Cap on head, suit that's red.
Special night, beard that's
white-
Must be Santa, must be
Santa,
Must be Santa, Santa Claus.

Who's got a great big cherry
nose?
Santa's got a great big
cherry nose.
Who laughs this way, "HO,
HO, HO."
Ho, Ho, Ho, cheery nose,
Cap on head, suit that's red.

Special night, beard that's
white-
Must be Santa, must be Santa
Must be Santa, Santa Claus.

Who very soon will come
our way?
Santa very soon will come
our way.
Eight little reindeer pull his
sleigh,
Santa's little reindeer pull his
sleigh.
Reindeer, Sleigh, come our
way,
Ho, Ho, Ho, cherry nose
Cap on Head, suit that's red
Special night, beard that's
white-
Must be Santa, Must be Santa
Must be Santa, Santa Claus

**CHRISTMAS TIME
Tune: Jingle Bells**

School is out, we won't pout
Cubs shout "Hip-Hurray"
Something special's coming
soon
And it's Christmas Day

Wrap the gifts, trim the tree
Mind your Mom and Dad
You'll get presents if you do
Boy, won't we be glad.

**PAGE 2 - DECEMBER - GIVING GIFTS
CRAFTSMAN/CITIZEN**

SANTA'S COMING

Tune: Santa's coming, Santa's coming

Hear the bells, hear the bells
You had better be good, you
had better be good
Little boy, Little boy

RING THOSE BELLS

Tune: Jimmy Crack Corn
Do motions as indicated in
each verse

1. Ring those bells and turn
around Ring those bells and
turn around Ring those bells
and turn around For
Christmas time has come
2. Ring those bells and
stomp your feet
3. Ring those bells and clap
your hands

RING, RING THE BELLS

Tune: Row, Row, Row, Your
Boat

Ring, Ring, Ring the bells
Ring them loud and clear
To tell the Cubs everywhere
That Christmas time is here.

HAPPY CUB SCOUT

Tune: Up on the Housetop

We are Cub Scouts and
we're happy boys
At Christmas time we share
our joys

We'll give some help to our
Mom and Dad
And try to help make
everyone glad.

Ho, Ho, Ho Who wouldn't
know
Ho, HO, Ho We know it's so
Now that we're Cub Scouts
we will be
Happy, loyal and trustworthy

CHRISTMAS UP AND DOWN

Tune: Grand Old Duke of
York

Start this song out sitting
down and whenever the
word "UP" is sung,
everyone stands up and
whenever the word "DOWN"
is sung, they all sit
down. When the audience
sings the line "ABOUT
HALFWAY UP", then the do
just that.

At Christmas time we try
To always bring good cheer
We'll keep it up and do our
best
To not let down next year
We will keep it up
And try to not let down
But if halfway we keep it up
Will we be up or down

We'll try to wear a SMILE
And keep it up you see

**PAGE 3 - DECEMBER - GIVING GIFTS
CRAFTSMAN/CITIZEN**

For when we're down, wear
a frown
And a Grump's not fun to be

JOY TO THE WORLD

Joy to the world, our Cubs
are here;
Let all the Pack rejoice
Their badges they have
earned today
Award them now without
delay
Let all the Pack give a cheer
Let all the Pack give a cheer
For those Cub Scouts who
advanced today

**COMIN' DOWN THE
CHIMNEY**

**Tune: She'll Be Coming
Around the Mountain**

He'll be comin' down the
chimney when he comes
He'll be coming down the
chimney when he comes
He'll be coming down the
chimney
He'll be coming down the
chimney
He'll be coming down the
chimney when he comes

He'll be bringing lots of
goodies.....

He'll have all of his

reindeer.....

And He'll need some milk and
cookies.....

He'll be comin down the
chimney.....

**SANTA
Tune:Bingo**

Every Cub Scout has a friend
And Santa is his name, Sir
S-A-N-T-A, S-A-N-T-A
S-A-N-T-A, and Santa is his
name/

Sing through 6 times

1. Just spelling S-A-N-T-A
2. Clap for the "S" and
spell-out the last 4 letters
3. Clap for the "S-A" and
spell-out the last 3 letters
4. Clap for the "S-A-N" and
spell-out the last 2 letters
5. Clap for the "S-A-N-T"
and spell-out the last letter
6. Clap for all 6 letters

**I'M PLAYING IN THE SNOW
Tune:I'm Singing in the Rain**

I'm playing in the snow
I'm playing in the snow
What a glorious feeling
It's snowing again

Making snowman tonight

for the whole world to see
I'm happy just playing
In the Snow

CUB CHRISTMAS CRAFT

A COLLECTION OF GIFTS & ORNAMENTS THAT CUBS CAN MAKE FOR THE HOLIDAY SEASON. DRAWN BY STACY H. WOOD

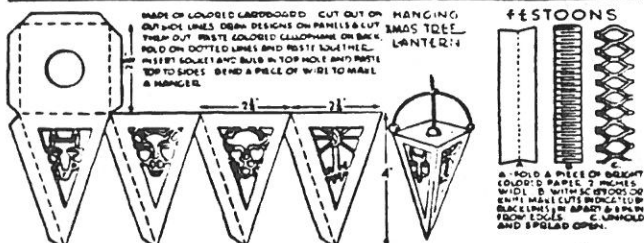

THE DEN EXPERIENCES HIGH

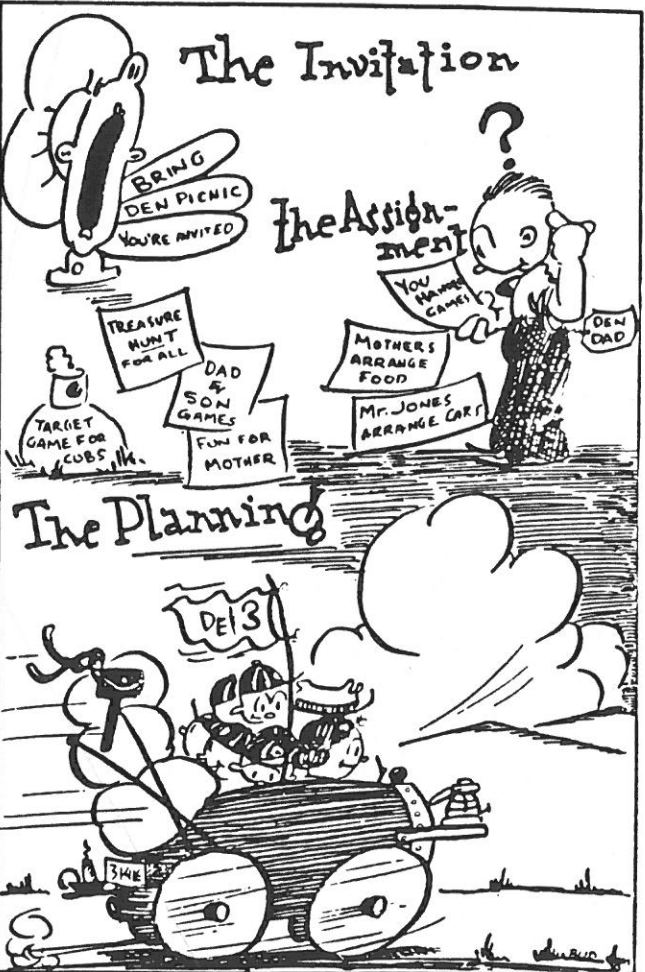

Use 1/4 inch
wood block two
by 1 1/2 inches.
Sand and color
desired. Glue ring
to back. Glue
colorful yarn
around it and tie
bow



birthday slide

Sparkly Snowmen

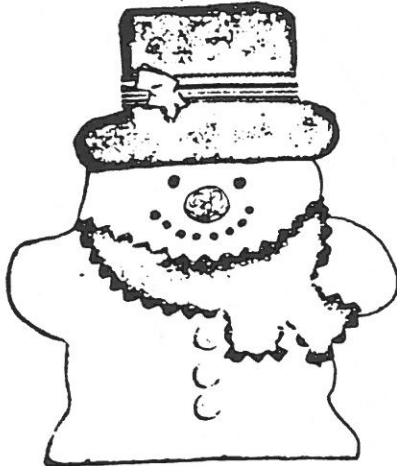

What makes these so lovable?
Pom-pom noses, a pudgy shape, and
great big toothy smiles!

You will need:

- Pencil
- Tracing paper
- Scissors
- 2 (5" x 5½") pieces of white felt
- Straight pins
- Scraps of colored felt, fabric, and ribbon
- Pinking shears
- 3 cotton balls
- White glue
- Small plastic buttons (or a hole punch to
make felt buttons)
- Small white pom-pom
- Black slick pen
- Clear glitter
- Fishing line



1. Trace and cut out the patterns.

2. Stack the white felt pieces and pin the snowman to them. Pin the hat to a scrap of colored felt. Cut out the felt pieces. Using the pinking shears, cut the scarf from a fabric scrap.

3. Put the cotton balls on one snowman tummy. Run a line of glue around the snowman's edges and place the other snowman on top. Pinch the edges of the snowmen together. Let the glue dry.

4. Glue the hat to the snowman's head. Cut a piece of ribbon for a hatband. Cut a tiny holly leaf and some berries from green and red felt. Glue the pieces to the hat and let dry.

5. Glue the scarf, buttons, and pom-pom nose in place. Let the glue dry.

6. Practice drawing dots on a scrap of felt, using the slick pen. Then draw two eyes and a mouth on the snowman. Let the paint dry.

7. Spread glue on the snowman and sprinkle him with glitter. When the glue is dry, shake off the excess glitter.

8. Use a pin to punch a hole in the top of the snowman's hat. Pull a piece of fishing line through the hole and tie the ends for a hanger.

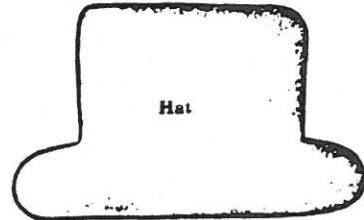

Hat

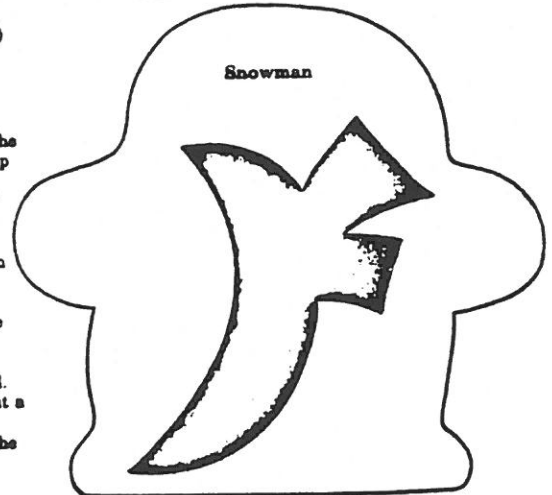

Snowman

HANUKKAH CARD

MATERIALS

- Construction paper
- White pipe cleaners
- Glue
- Scissors
- Colored pipe cleaners

DIRECTIONS

1. Fold a sheet of construction in half.
2. Draw and cut menorah from yellow construction paper.
3. Glue the menorah to the front of the card.
4. Cut pieces of white pipe cleaners for candles and colored pipe cleaners for the flames on the candles.
5. Write a message inside the card.



Hanukkah Card

PAGE 6 - DECEMBER - GIVING GIFTS CRAFTSMAN/CITIZEN

JUICE CAN LID TIN PUNCH

MATERIALS

12 oz juice can lid
Scissors
Nails
Hammer
Scotch Tape
Paper Dollies or Eyelet lace
Ribbon
Pine shelving

DIRECTIONS

1. Cut pattern on the circle surrounding it.
2. Roll a piece of scotch tape or use two sided tape to tape the pattern to the center of the juice can lid.
3. Place the juice can lid on a small piece of pine shelving. You can tape it down to make it easier.
4. Using a nail and a hammer punch a hole in the juice can lid at every dot on the pattern.
5. Punch two holes at the top close together for the hanger.
6. Hold the lid up to the light before removing the pattern to make sure that all the holes are punched.
7. Remove the pattern and string a piece of ribbon through one of the top holes and back through the other. Tie together for the hanger.
8. Glue the lid onto a paper dolly or glue eyelet lace around the side of the pack. Be careful not to get glue into the holes.
9. Make a small bow and glue just above the juice can lid where it meets the dolly at the top.

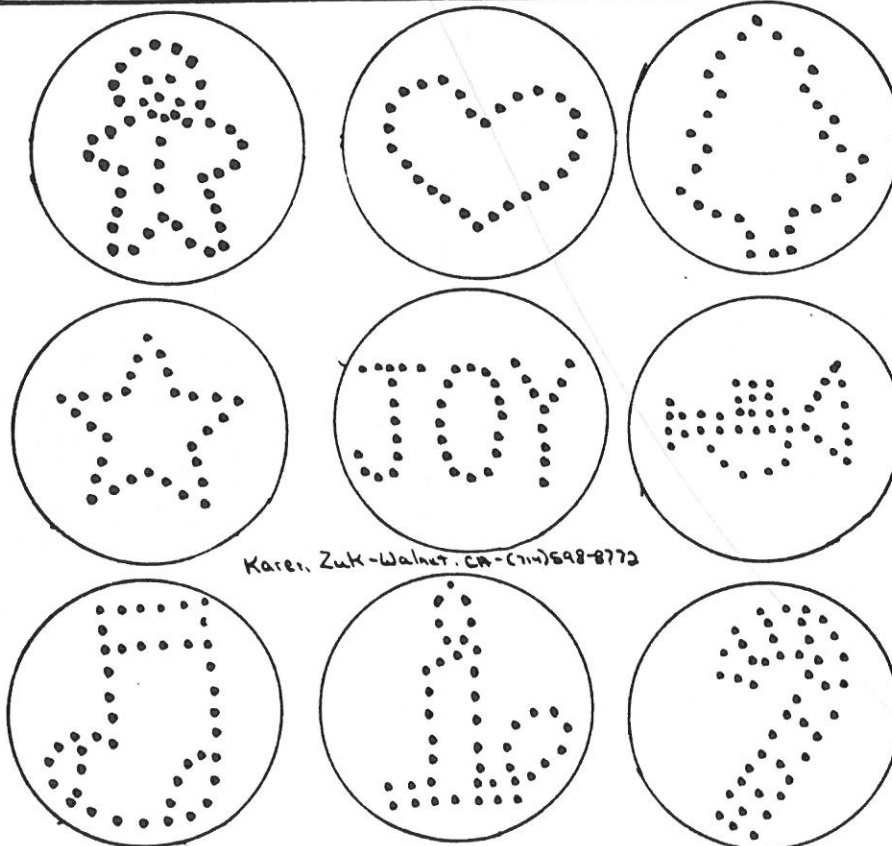
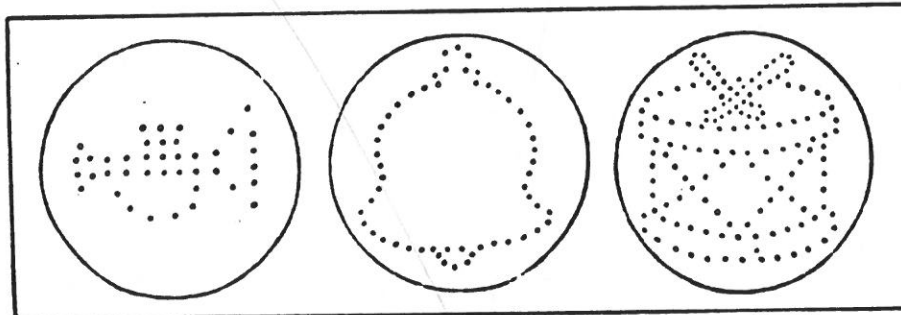

Karer, Zuk-Walner, CA-(714)598-8772

