

OLD BALDY COUNCIL PRESENTS

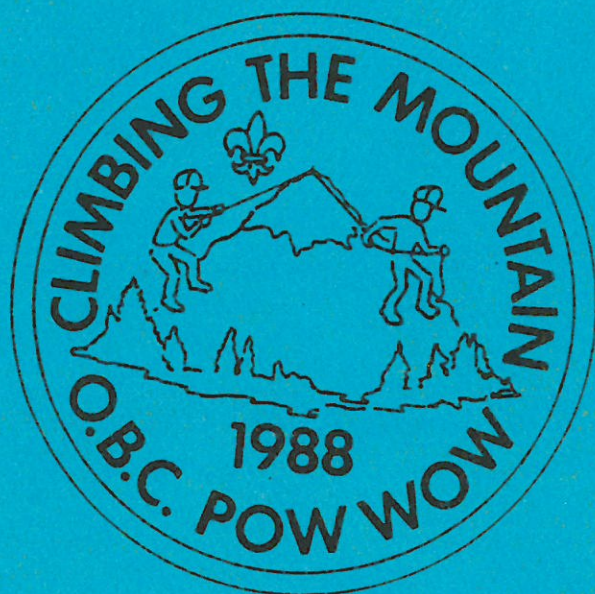

POW WOW 1988

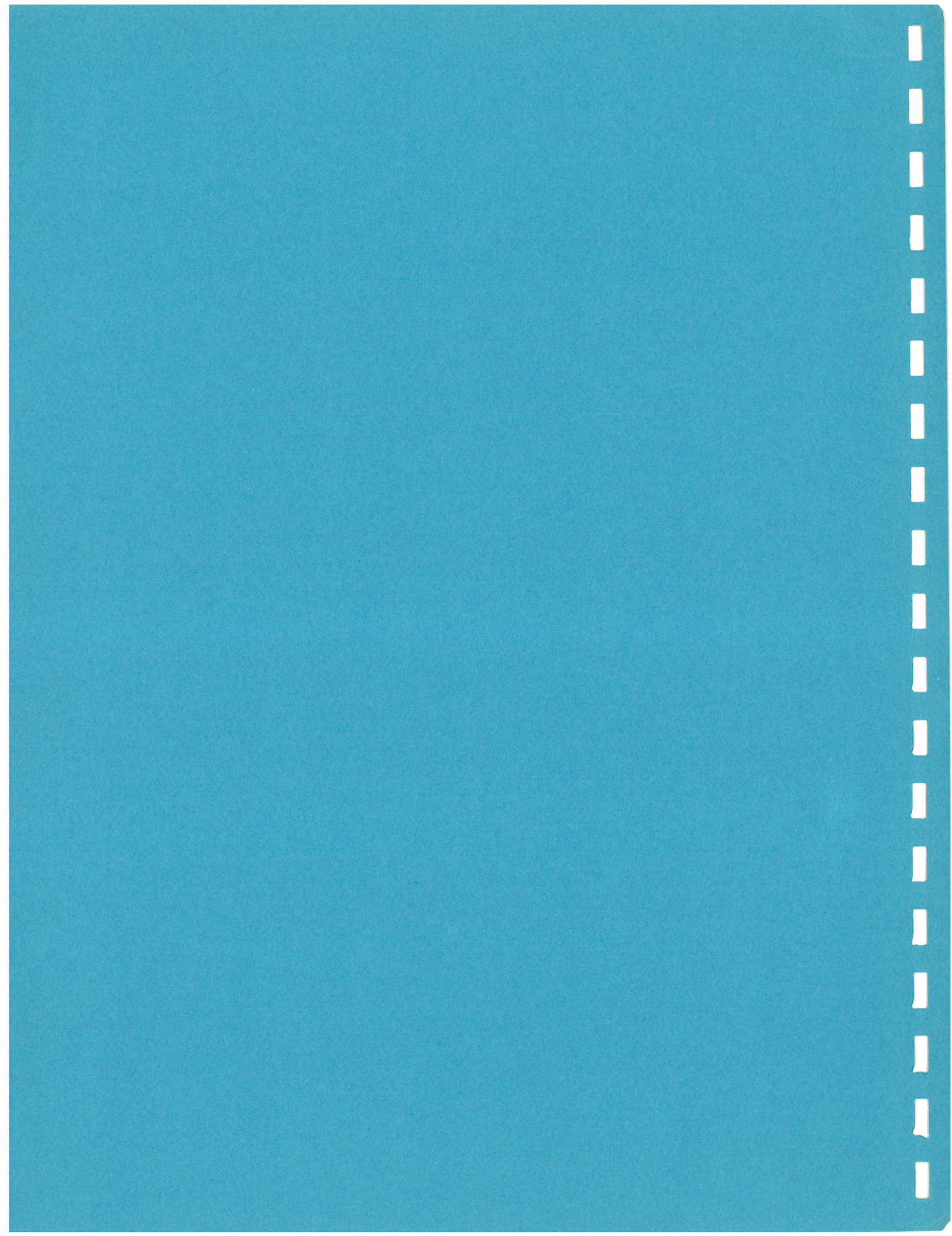

FOUNDER'S PRAYER

Father of us all,

We meet before Thee here today,
numerous in the lands we come from
and in the races we represent,
but one in our Brotherhood
under Thy Divine Fatherhood.

We come before Thee
with hearts grateful and gladdened
by the many blessings
Thou hast granted us
and thankful that our Movement
has prospered as acceptable
in Thy sight.

In return
we would lay on Thine Altar,
as our humble thank-offering,
such sacrifice as we can make
of self in service for others.

We ask that during our communion
here together we may,
under Thy Divine Inspiration,
gain a widened outlook,
a clearer vision of all
that lies open before us
and of our opportunity.

Thus may we then go forth
with strengthened faith
to carry on our mission
of heightening the ideals
and powers of manhood,
and of helping through closer understanding
to bring about Thy happier Rule of
Peace and Goodwill upon Earth.

Hear us, O Father.

Baden-Powell

SCOUT EXECUTIVE'S MINUTE

A young man came to my door the other day to sell me a Scout-O-Rama ticket. When I asked him what Cub Scouts do, he proceeded to tell me about games, going to camp with his dad, earning badges and lots of things. I asked him how long he had been a Cub Scout, and his reply was, "I went to my first meeting yesterday."

Someone really has this young man excited about being a Cub Scout. We can help keep him from being disappointed by doing those things that ensure his dreams will come true.

Training is the first step to bringing a quality program to the young people we volunteer to lead.

Welcome to the 1988 Cub Leaders Pow-Wow. We're Glad you're here!

William K Gruber
Scout Executive
Old Baldy Council

CHAIRMAN'S LETTER OF APPRECIATION

I would like to express my gratitude to those who truly did make a sacrifice in service for others as Lord Baden-Powell stated in his founder's Prayer.

Our purpose today, both participant and staff, is the same--that is to carry on the "mission of heightening the ideals and powers of manhood."

I thank those who have donated their time unselfishly for strengthening the Cub Scout program.

Linda Manhart
Pow Wow Chairman

THANK YOU TO OUR ADVERTISERS FOR THEIR
SPONSORSHIP OF OUR 1988 POW WOW BOOK

WE WOULD APPRECIATE YOUR PATRONAGE
OF THESE BUSINESS

**BUILDING MATERIALS
HARDWOODS**

- Complete line of Hardware & Tools
- Bathroom Vanities
- Electrical & Plumbing Supplies
- Roofing Materials
- Garden Supplies
- Fencing Materials & Installation
- Glass
- Insulation
- Paint
- Paneling

OPEN SUNDAYS 9-3



SINCE
1929



120 S. Euclid Ave.
Upland

982-8857



**Welcome To
Rugg Lumber Company**

Whether you have been in the area a short time or long time, we are here to serve your maintenance needs.

Rugg Lumber was established at this location in 1929 and has served the building supply needs to the community for over a half a century.

Rugg Lumber is a family owned business now in its third generation, and we have taken great pride in emphasizing courteous service to our customers.

Our fully trained and professional staff is always available to answer questions and to assist you in any way we can.

Come visit us soon and enjoy an inventory of over 20,000 items to serve your supply needs.

Open Mon. - Fri. 7:30 p.m. - 5:30 p.m.
Sat. 8:00 a.m. - 5:30 p.m.
Sun. 9:00 a.m. - 3:00 p.m.

120 S. Euclid Ave., Upland
982-8857

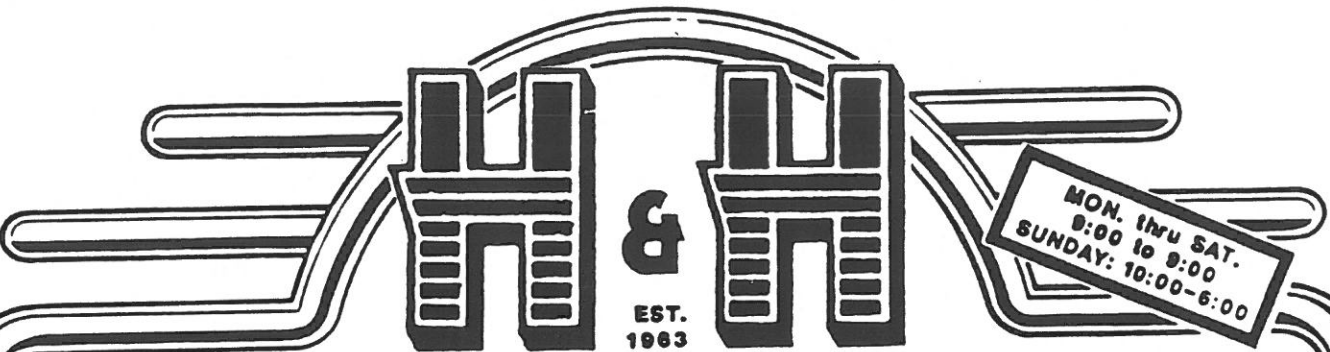

EST. 1963

CRAFT & FLORAL SUPPLY CO

★ TROOP & GROUP ★ HEADQUARTERS

STYROFOAM
ART SUPPLY
CANDLES
PARTY SUPPLY
MACRAME
RATTAN
POM-POMS

SILK TREES & PLANTS
PICTURE FRAMES
FLORAL ARRANGEMENTS
FLORAL SUPPLY
BEADS-SEQUINS
WEDDING SUPPLY
NEEDLECRAFT KITS

SILK FLOWERS
PLASTERWARE
DRY FLOWERS
ART & CRAFT BOOKS
DOLL SUPPLY
CAKE & CANDY SUPPLY
AND MUCH MORE



WE'VE GOT WHAT YOU NEED...



COUPON

YOUR ENTIRE PURCHASE!

NOT VALID WITH OTHER PROMOTIONS

20% OFF

YOUR ENTIRE PURCHASE!

COUPON EXPIRES 12-1-88

COUPON

ASK-US-ABOUT
NON PROFIT
ORGANIZATION
DISCOUNTS...

MONTCLAIR

621-3807

9061 CENTRAL AVE.

WHOLESALE & RETAIL
OPEN TO PUBLIC

1988 Old Baldy Pow Wow Staff

Chairman	Linda Manhart	(714) 629-9508
Fund Raising	Ruth Parker	(714) 980-1300
Pow Wow Book	Marla Lefler	(714) 626-2048
Midway	Phil Tate	(714) 391-4152
Registration	Barbara Reynolds	(714) 626-0278
Food Service	Roy Cooley	(714) 621-2171

CLASSES

Nature	Denise Morris	(714) 621-5513
Cub Scout Sports	Fred Moore	(714) 624-9203
Compass	"	"
Crafts	Norma Bergman	(714) 629-9203
Whittling Craft	Win Walker	(714) 984-5215
Ceremonies	Gary Galbreith	(714) 947-4404
Magic	Debbie Balbilius	(714) 861-5902
Songs	Jeff & Bev Cain	(714) 596-4106
Religious Awards	Patty Moore	(714) 624-9203
Cub Adventure	Dan Manhart	(714) 629-9508
	Chuck Massar	(714) 861-0374
Games	Allan McAlister	(818) 798-5157
Puppets	Sharon Galbreith	(714) 947-4404
Tiger Cubs	Tacie Adams	(714) 597-8538
Webelos/Scout Transition	Bill Bergman	(714) 629-8978
Cub Scout First Aid	Marilyn Ruzicka	(714) 861-7406
Forms	Sue Prior	(714) 626-0993
Skits	John Shelburne	(714) 810-2111

Recruiter	Marilyn Ruzicka	(714) 861-7406
Knots	Dan Manhart	(714) 629-9508
Changes in Program	Linda Manhart Fred Moore	(714) 629-9508 (714) 624-9203
Family Enrichment	Doug Kroll	(714) 624-0405
Clowns	Fred Hogg	
Patch It Up	Greg Risser	(714) 369-1805
Sparklers	Stan Stolpe	(714) 498-1665

POW WOW THEMES

JANUARY	KNIGHTS IN ARMOR
FEBRUARY	STRONG FOR AMERICA
MARCH	EXPLORING ALASKA
MAY	WHEELS, WINGS & RUDDERS
APRIL	CUB SCOUT HANDYMAN
JUNE	AKELA'S COUNCIL
JULY	TRAILS, TREKS & TRIPS
AUGUST	OUTDOOR FESTIVAL
SEPTEMBER	OUR AMERICAN HERITAGE
OCTOBER	VIKING DISCOVERIES
NOVEMBER	PARADE OF PRESIDENTS
DECEMBER	CUSTOMS OF COUNTRIES

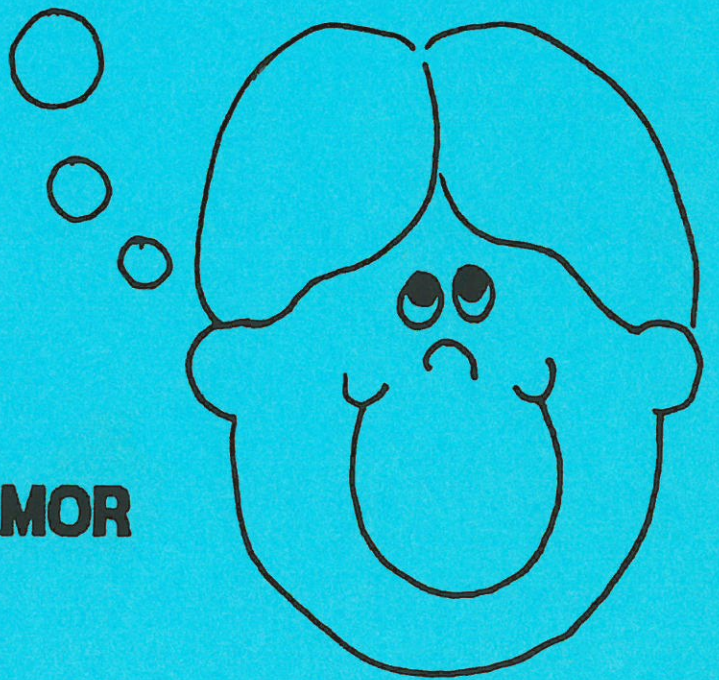
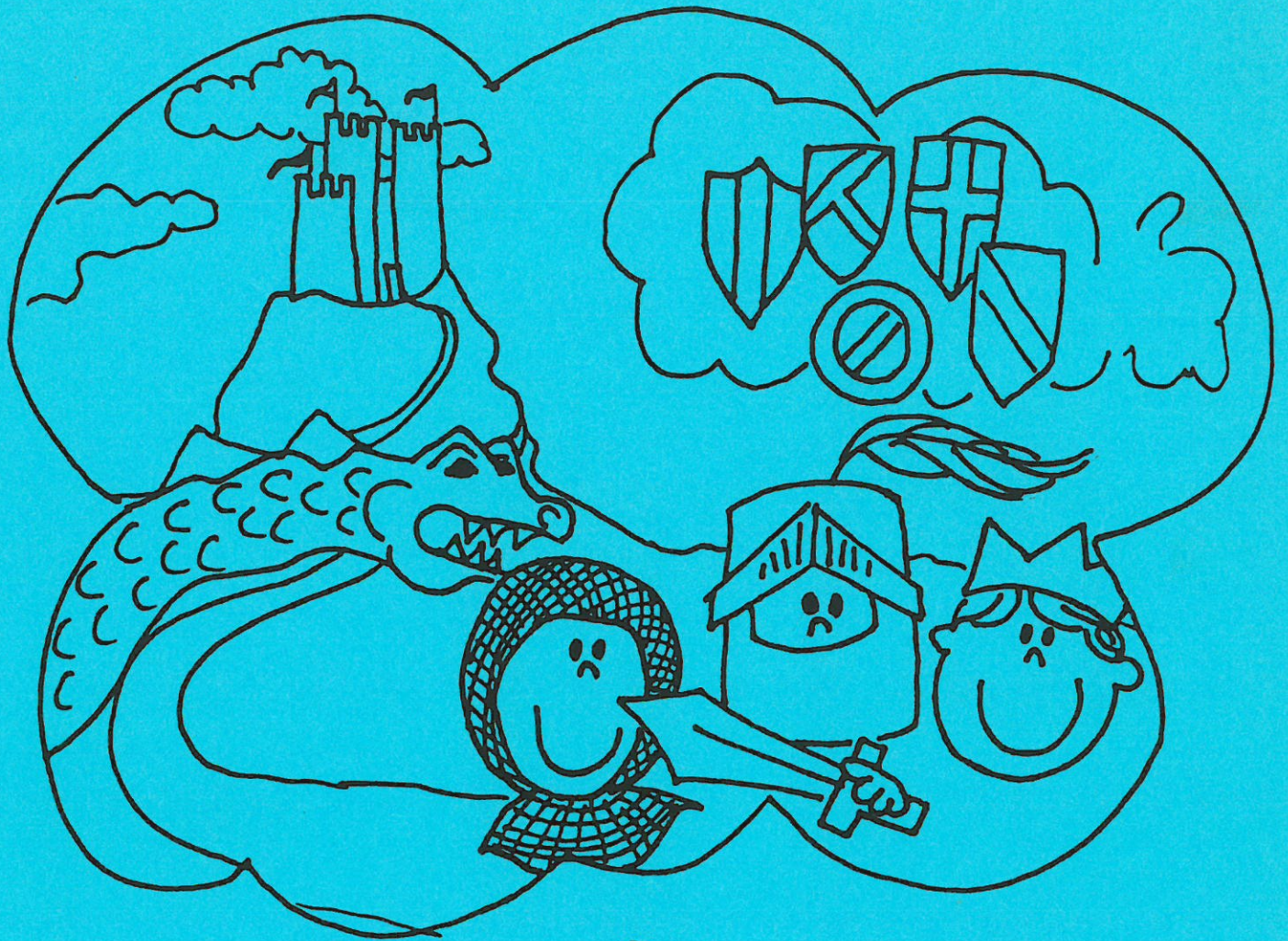

**JANUARY
KNIGHTS IN ARMOR**

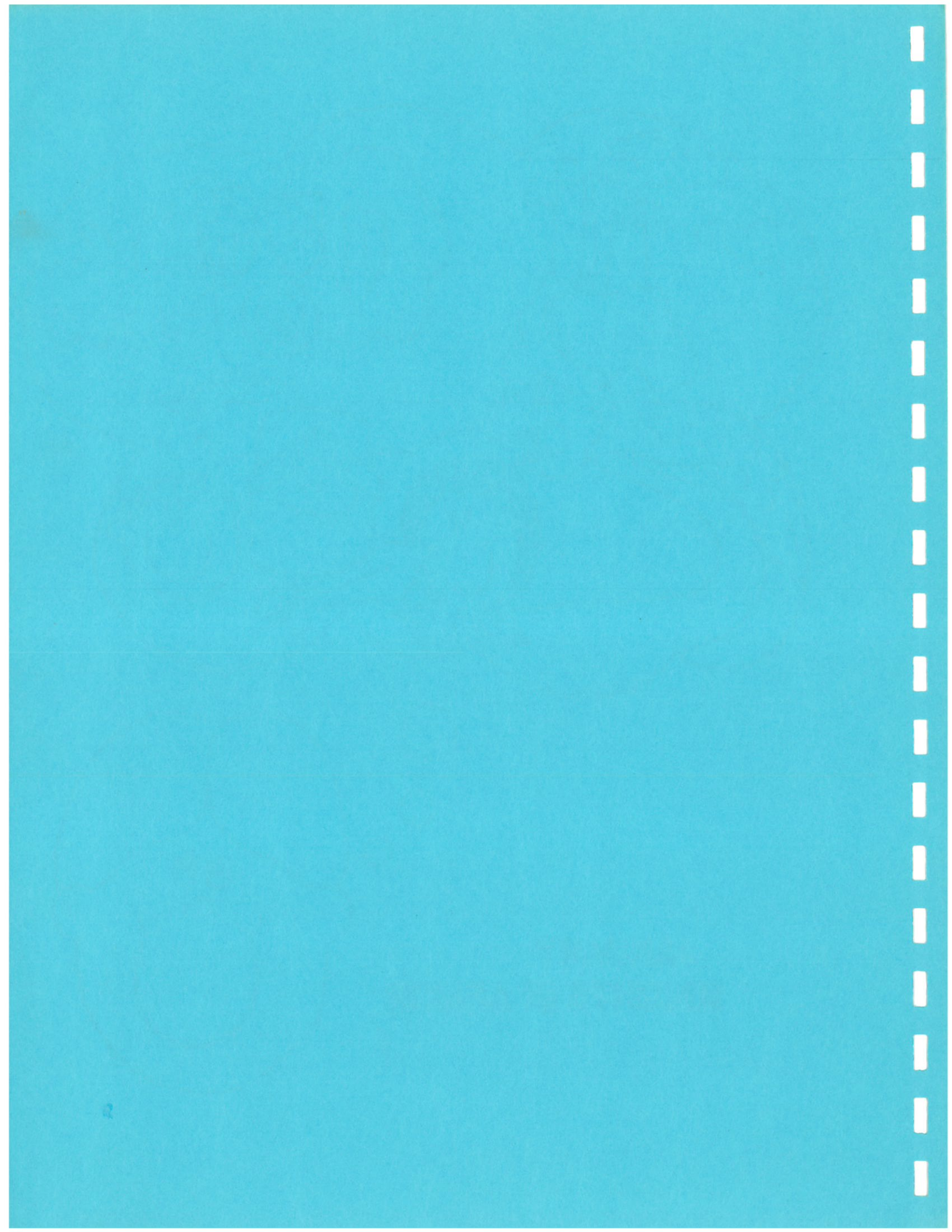

JANUARY KNIGHTS IN ARMOR



THE KNIGHTS CODE

"BE ALWAYS READY with your armor on, except when you are taking your rest at night.

Defend the poor, and help them that cannot defend themselves.

Do nothing to hurt or offend anyone else.

Be prepared to fight in the defense of your country.

At whatever you are working, try to win honor and a name in honesty.

Never break your promise.

Maintain the honor of your country with your life.

Rather die honest than live shamelessly.

Chivalry requireth that youth should be trained to perform the most laborious and humble offices with cheerfulness and grace, and to do good unto others."

(Write the code on a Scroll and have the Cubmaster read it as an opening.)

DID YOU KNOW: Baden-Powell got the Scout motto and developed the Scout Law from the code of the knights of old.

IDEAS FOR CEREMONIES:

Cubmaster comes in dressed in a knights costume (as simple as a tunic over a uniform)

Cubmaster could be dressed as a king or queen and knight the cubs as they receive their rank. ie. I knight you _____ may you serve in you rank as _____, I hereby award you your _____ badge.

The den leaders are dressed as fair maidens and/or knights.

Den Chiefs can be dressed as court jesters.

Cub Scouts and Webelos could make

helmets and masks.

Your pack meeting could be held in a large circle as in "Knights of the Roundtable."

Webelos could do a skit for showman and make scenery with a dragon and props.

RESOURCES

The Library

District Roundtables

Cub Scout & Webelos Program

Helps

OPENING

KNIGHTS IN ARMOR OPENING

We the Knights in Armor, are bound together in a circle of steel. Let this steel wall remind us to keep from our land and from our daily lives those things that are not in keeping with our code of honor. Now, Knights with your left hands on your swords, give the sign of your knighthood. (They give the Cub Scout sign). May the spirit of Cub Scouting and the meaning of liberty, freedom and honor be demonstrated by you for all to see each day of your life.

Knights, parents and friends gathered here tonight will you all join me in "The Pledge of Allegiance to the Flag"?





CLOSING THOUGHT -CODE OF THE KNIGHTS

From Lord Baden-Powell's "Scouting for Boys"

The Knight's patrol used to stick to him through thick and thin, and all carried out the same idea as their leader -namely:

- Their honor was sacred.
- They were loyal to God, their king, and their country.
- They were particularly courteous and polite to all women, children and weak people.
- They were helpful to everybody.
- They gave money and food where it was needed and saved up their money to do so.
- They taught themselves the use of arms in order to protect their religion and their country against enemies.
- They kept themselves strong and healthy and active to be able to do these things well.

You, Cub Scouts, cannot do better than to follow the example of the knights.

LIVING CIRCLE FOR KNIGHTS MONTEREY COUNCIL

NARRATOR: Knights of old stood straight and tall as they pledged themselves to fight for all things that were good and to strive to always do right. Our Cub Scouts today stand straight and tall as they pledge themselves to do good by taking the Cub Scout promise as their code. Let each of us now tonight silently pledge to live up to a good knight's code of doing good for our fellow men.

ADVANCEMENTS

KNIGHT ADVANCEMENT

EQUIPMENT: A knight's sword made of heavy cardboard or plywood for each boy who is advancing in rank. Cubmaster is dressed as King Arthur. Fasten badges and cards to swords.

Cubmaster: Like in Cub Scouting, a boy that wanted to become a knight started his training at about the age of eight. He learned good manners, did errands, and learned to sing and play. He also learned fair play and consideration for others. As he grew older, again like a Cub Scout, his duties became harder. He learned how to take care of his knight's armor, horses and weapons. Finally the young squire was tested and took his vows to become a knight. Among other things he vowed to do his duty to his God, to serve his King bravely and to be fair, kind and truthful.

Tonight we have in our pack some squires who have been tested and have taken their vows to become knights. Will the following squires come forward and kneel in front. (Call names of each boy advancing in rank) In the name of Akela, the King of the Order of the Webelos, I dub thee Sir Wolf (Name of Cub Scout). (Repeat for each Wolf and present him with a sword. Then follow same procedure for Bear and boys going into Webelos den).

(Call forward boys receiving arrow points and/or activity badges) We have some knights with us tonight who have brought honor to their castles by completing some electives and/or activity badge requirements. For



KNIGHT ADVANCEMENT - CONT'D

these knights we have arrow points and/or badges. In the name of Akela, the King of the Order of the Webelos, I present Sir (Name of Cub) with (Gold and/or silver arrow points and/or activity badges).

Congradulations to all of you. As you leave this meeting, may you carry with you the spirit of true knighthood.

THE KNIGHTS OF YOU'RE MONTEREY COUNCIL

1st Knight: The teme is "Knights in Armor" So, we are presenting the Knights of yesterday -- today and tomorrow. I am Monday Knight.

2nd Knight: We represent the knights of the week and strong. I am Tuesday Knight.

3rd Knight: We have discarded the tennis rackets of King Arthur's Court for the football of King Kennedy's field. I am Wednesday Knight.

4th Knight: I am Thrusday Knight. I wish to introduce Friday Knight.

5th Knight: I'm Friday Knight. I'm sorry we can't go on with this skit because Saturday

and Sunday are setting on their weekend.

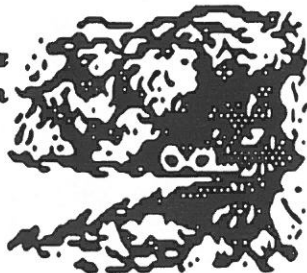

AUDIENCE PATRICIPATION

**THE FAIR MAIDEN'S PLIGHT
DIVIDE GROUP INTO 4
PARTS**

KNIGHTS	CLANKETY-CLANK
MAIDEN	HELP! HELP!
MEAN KING	G-R-R-R-R
DRAGON	HOAR-R-R-R

Back in the day of bold KNIGHTS and fair MAIDENS there lived a MEAN KING with his daughter who was indeed the most beautiful MAIDEN in all the land. All those who passed by their castle would see this fair MAIDEN sitting by the hour in the window longing to be set free.

It was told about the land that this fair MAIDEN had a curse put upon her by the wicked witch that if a DRAGON which lived in the woods close by were to look upon her she would suddenly become the most ugly MAIDEN that lived, so that was why the MEAN KING kept her locked within the castle.

Of course, after hearing this all the brave KNIGHTS for miles around came to that part of the land hoping to kill the terrible DRAGON and thus save the fair MAIDEN from a terrible fate.

Night and day the brave young KNIGHTS searched for that terrible DRAGON. Each hoping to be the one to save the fair MAIDEN and take her away from the castle of the MEAN KING.

However, one day there came a gallant KNIGHT who was much wiser than all the rest. He decided that since the DRAGON was no



FAIR MAIDEN CONT'D

where to be found that maybe there was another reason why the MAIDEN didn't come out.

So he rode his horse as swiftly as he could and charged at full speed right through the door of the castle sending debris and rubble flying in all directions.

It seems the MAIDEN couldn't find the door because the castle was such a mess and that's why she hadn't come out.

The brave young KNIGHT bounded up the stairs and carried his fair MAIDEN down and put her on his horse and rode away from the castle of the MEAN KING and left the other KNIGHTS in the land still searching for the terrible DRAGON while he saved the damsel in distress right out of her terrible mess.

GAMES

CROSSING THE MOAT

For a drawbridge, set a long plank(at least 12" wide) on the floor. The knight, in full dress, must try to walk across the drawbridge. If he falls off the plank on either side, he is in the "moat": mark the distance he has gone. The Knight who successfully crosses the drawbridge or goes the farthest, is the winner. You may set a time limit, if you want.

Variation: Place 2"x4" or 1"x4" board flat on the floor. Blindfold knight. Use same scoring as above.

**you can use games of skill as listed in the Program Helps for games.

SONGS

CUB SCOUT SONG BOOK:
THE GRAND OLD DUKE OF YORK
THE QUARTERMASTER'S STORE
THE CANADIAN INFANTRY

BE GAME, BE FAIR
TUNE: My Bonnie

As Cubs Scouts we'll always be happy,
Be loyal, be game and be fair,
And Soon by our work and endeavor,
Be Wolf Cubs or Web'los or Bear.

Be game---be fair---
We'll do our best everywhere we go,
Be game-- be fair--
Cubs give goodwill where they go.

KNIGHTS ARE PREPARED
TUNE: ON TOP OF OLD SMOKEY

The knights of the roundtable
Are preparing to do
A battle royal
For their honor true.

Their horses are ready
but will they last
Speed and good luck
We hope they are fast.

We cheer for the brave knight
He will do his best
He'll come home a winner
And then he can rest.



SEE NEXT PAGE



SONGS

KNIGHTS' SONG

TUNE: YANKEE DOODLE

This month we've learned of
knights of old
And we would like to shout it,
That knights and Cubs are much
alike

And don't you ever doubt it.

Chorus:

Knights of old and Cub Scouts, too,
Both promise they will live right.
If they do the things they should,
Their presence makes the day
bright.

KING RICHARD FELL IN A MOAT

**TUNE: WHEN JOHNNY
COMES MARCHING HOME**

King Richard fell in the moat today,
Hurrah! Hurrah!

King Richard fell in the moat today,
Hurrah! Hurrah!

King Richard fell in the moat today,
And Robinn Hood came along the
way,

And that was their .yes.their very
GOOD DEED FOR THE DAY!

CLOSING

KNIGHTS IN ARMOR

1st CUB: If I had been a knight of
yore

2nd CUB: I would have opened up
the door.

3rd CUB: For queens and ladies to
pass thru.

4th CUB: I would have been
trustworthy, true:

5th CUB: I would have ridden
giant steeds,

6th CUB: Accomplishing note-
worthy deeds!

7th CUB: Today, there are no
Knights about,

8th CUB: And so I have become a
Cub Scout!

CRAFTS

IDEAS FOR KNIGHTS



**FOR THE HELMET,
USE A GALLON-SIZE
ICE-CREAM CONTAINER**

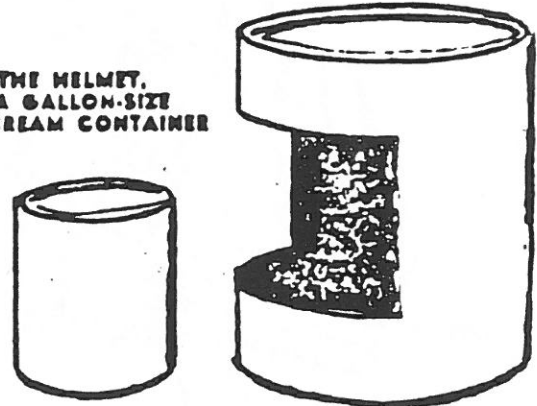

**CUT AS SHOWN, AND
ADD VISOR, WINGS,
PLUMES, ETC.**



**WINTER SKULLCAP
PAINTED TO LOOK
LIKE MAIL**

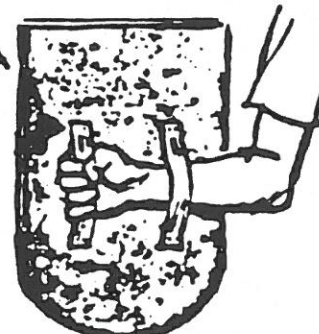

**CARDBOARD SHIELD
WITH CARDBOARD
STRAPS**



WALKING KNIGHT

CRAFTS - CONT'D

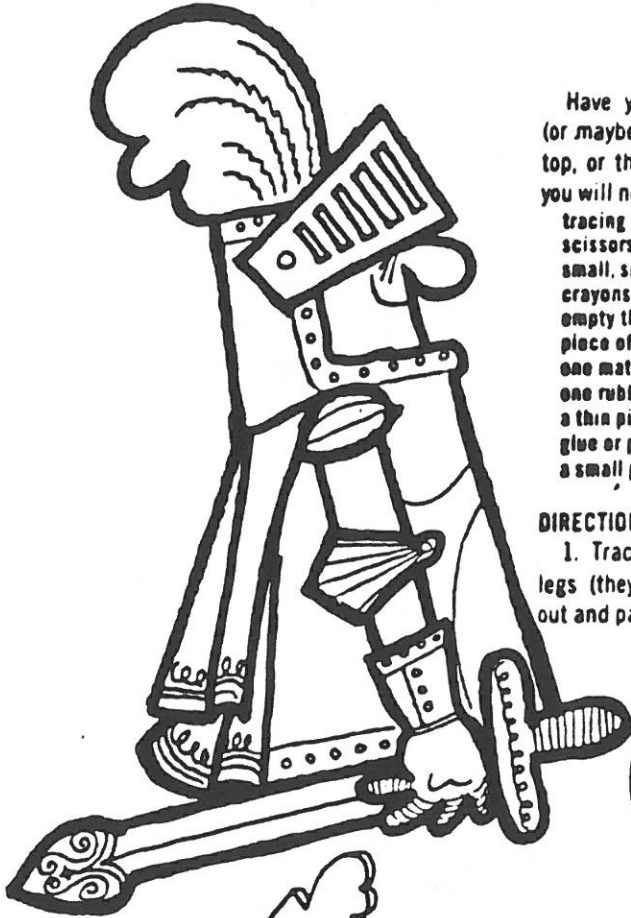

Have you ever seen a knight walk (or maybe rock and roll) across a table top, or the floor? To make this knight you will need:

- tracing paper
- scissors
- small, sharp knife
- crayons, colored chalk or water colors
- empty thread spool
- piece of cardboard
- one match stick
- one rubber band
- a thin piece of soap
- glue or paste
- a small piece of stick

DIRECTIONS:

1. Trace over the knight and his legs (they're round). Cut both pieces out and paste them down on cardboard.

Now, trim carefully around both, and color them. Put the rubber band over the match, then glue the match to the back of the cut out body. Glue the legs to one side of the spool.

2. Cut a "washer" from the thin bar of soap.

3. Put the "washer" over the rubber band and slide it against the match.

4. Next, slide the spool over the rubber band and put a small piece of stick through the band. Glue in place across the spool hole.

5. Now you're ready for the real fun! Hold the spool in your left hand and wind up the rubber band with the stick as shown here. Put your knight down on a smooth surface and watch him go!

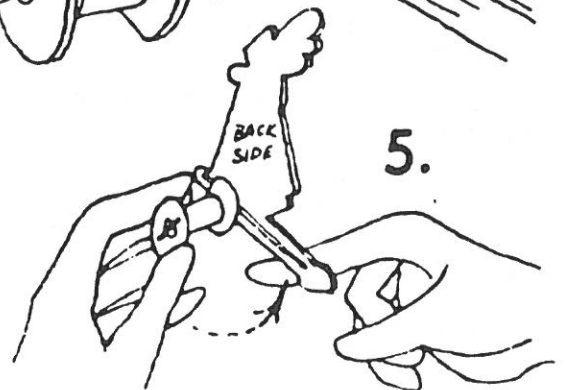
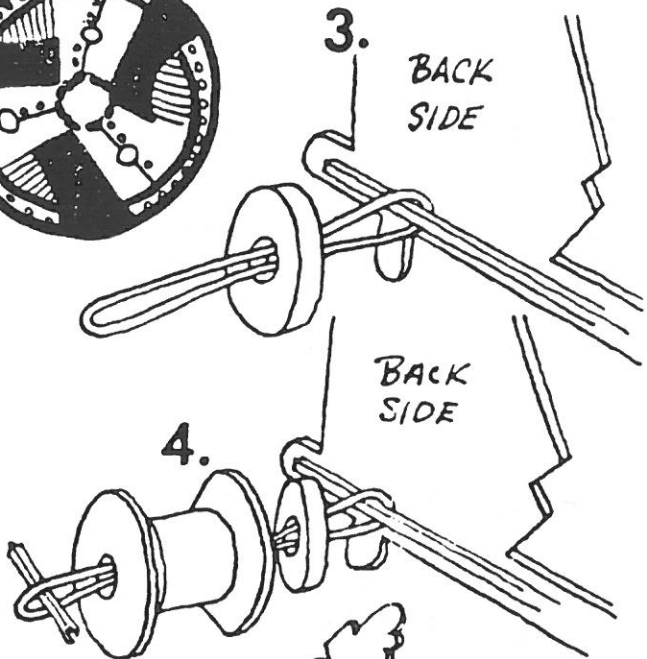
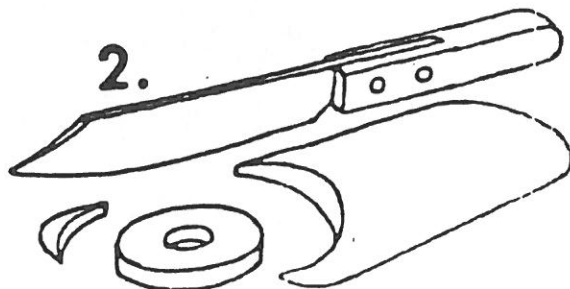
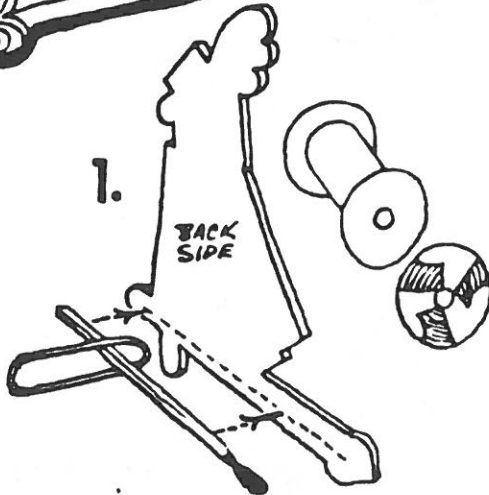
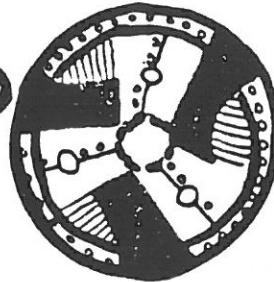



CRAFTS - CONT'D

SHINING ARMOR

Have your knights in shining armor. You'll need flexible sheets of corrugated cardboard, used in packing, and some heavy aluminum foil. For this suit of armor, cut the cardboard into the following pieces to fit: Upper and lower arms, upper and lower legs, chest plate and back plate (cut same as chest plate but in two pieces with a 2" overlap down the center.) Tape chest and back plates together across shoulders and down sides.



To wear, overlap back plate and tie together at neck and waist. Roll each arm and leg piece into a cylinder and overlap and tape edges. Cover all pieces with aluminum foil, allowing a little extra for folding around edges. To connect limbs, hinge inside elbows and behind knees with tape and string. Tape and tie upper arms to inside of chest plate under arm holes, On side points of upper legs, attach strings to tie legs to belt. For shoulder pieces, use a triple thickness of aluminum foil. Cut to shape shown and fold back edges to finish and strengthen. Attach to chest plate and back plate with paper fasteners. For waist plates, cut 24" piece of foil, double thick, 2" to 3" x 4" to 6". Fold edges under. Glue and tape a row to inside bottom of chest plate. Glue and tape others behind and between.

To make helmet, cut cardboard in the shape shown. Along top, cut 6" points. Roll cardboard into a cylinder, bonding points toward the center. Glue and tape points together. Mark and cut an opening in the front of your helmet. Cover helmet with foil. For the visor, cut a piece of cardboard to fit across opening, with plenty extra for raising visor. To slot visor, cut and remove every other pair of corrugations. Crease on dotted line and cover with aluminum foil. Attach at sides of opening in helmet with paper fasteners. For plumage, use an ostrich feather or roll some aluminum foil into a tube and cut narrow slits.



CRAFTS - CONT'D

TIE SLIDE OF THE MONTH



SHIELD TIE SLIDE

Cut the pieces for this slide from plastic bottles. By using different colored bottle you can achieve many effects. Fasten a ring on the back with a paper fastener and decorate with permanent felt markers.

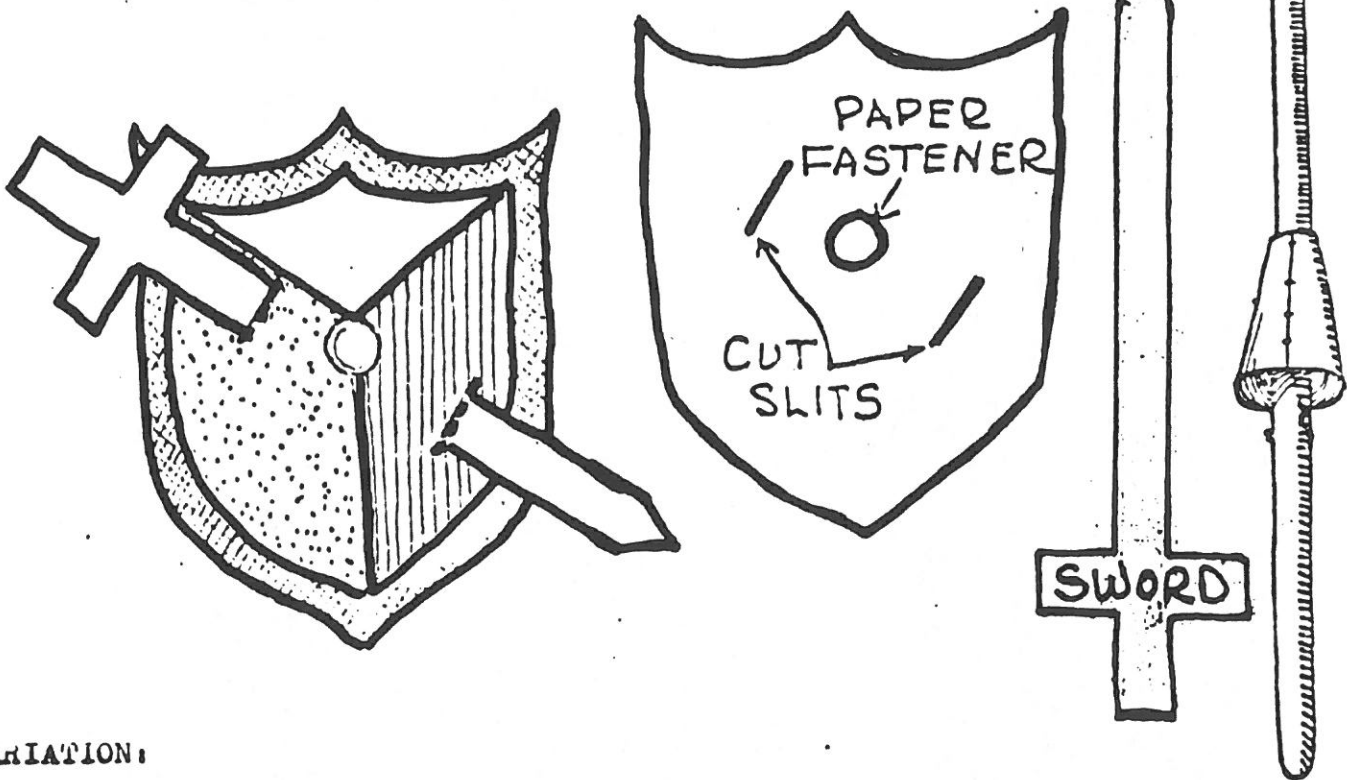

VARIATION:

Cut the shield pieces from leather or vinyl. On leather make you designs either by leather stamping or use a wood burner. Glue a loop for your neckerchief on the back with a good leather glue.

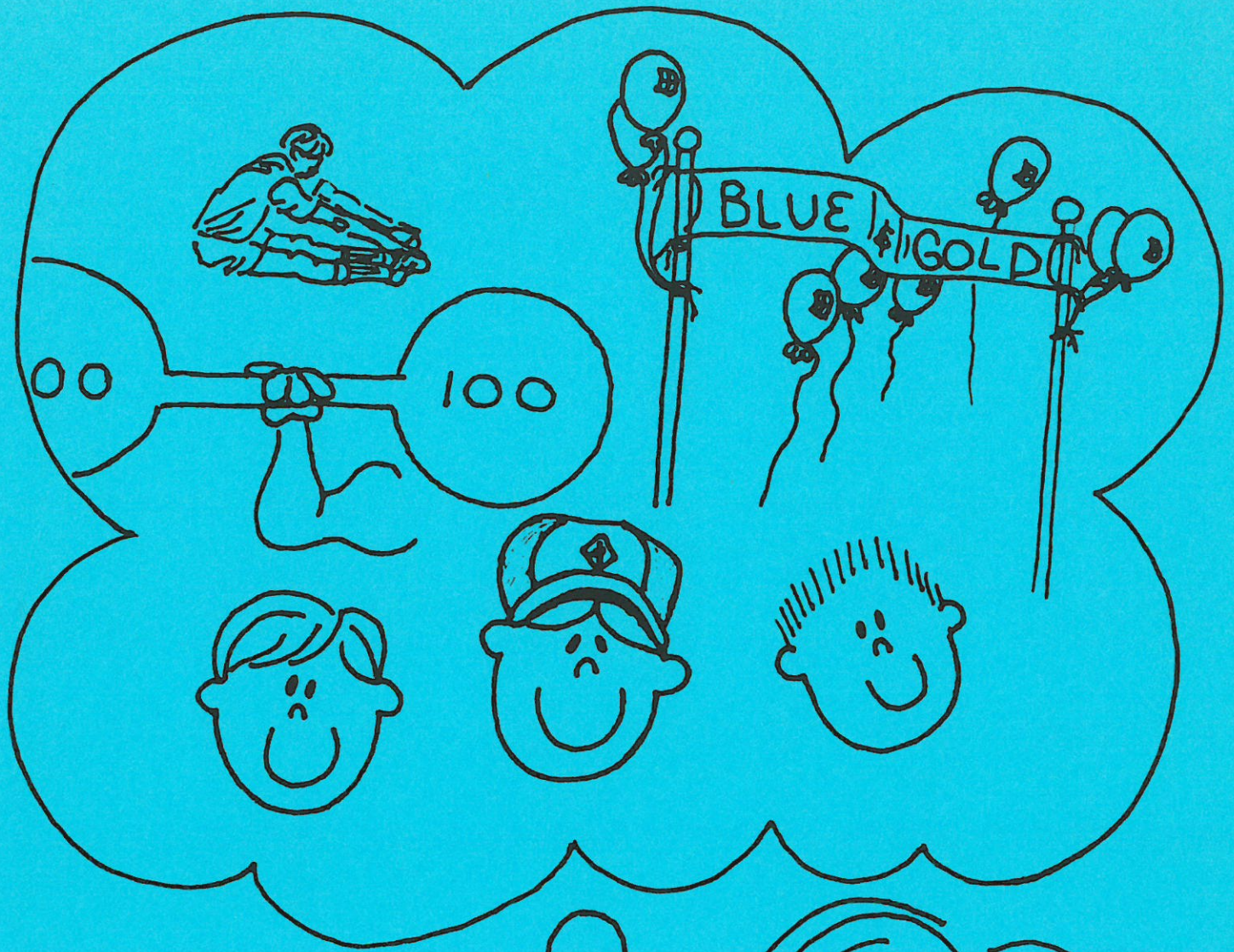

**FEBRUARY
STRONG FOR AMERICA**



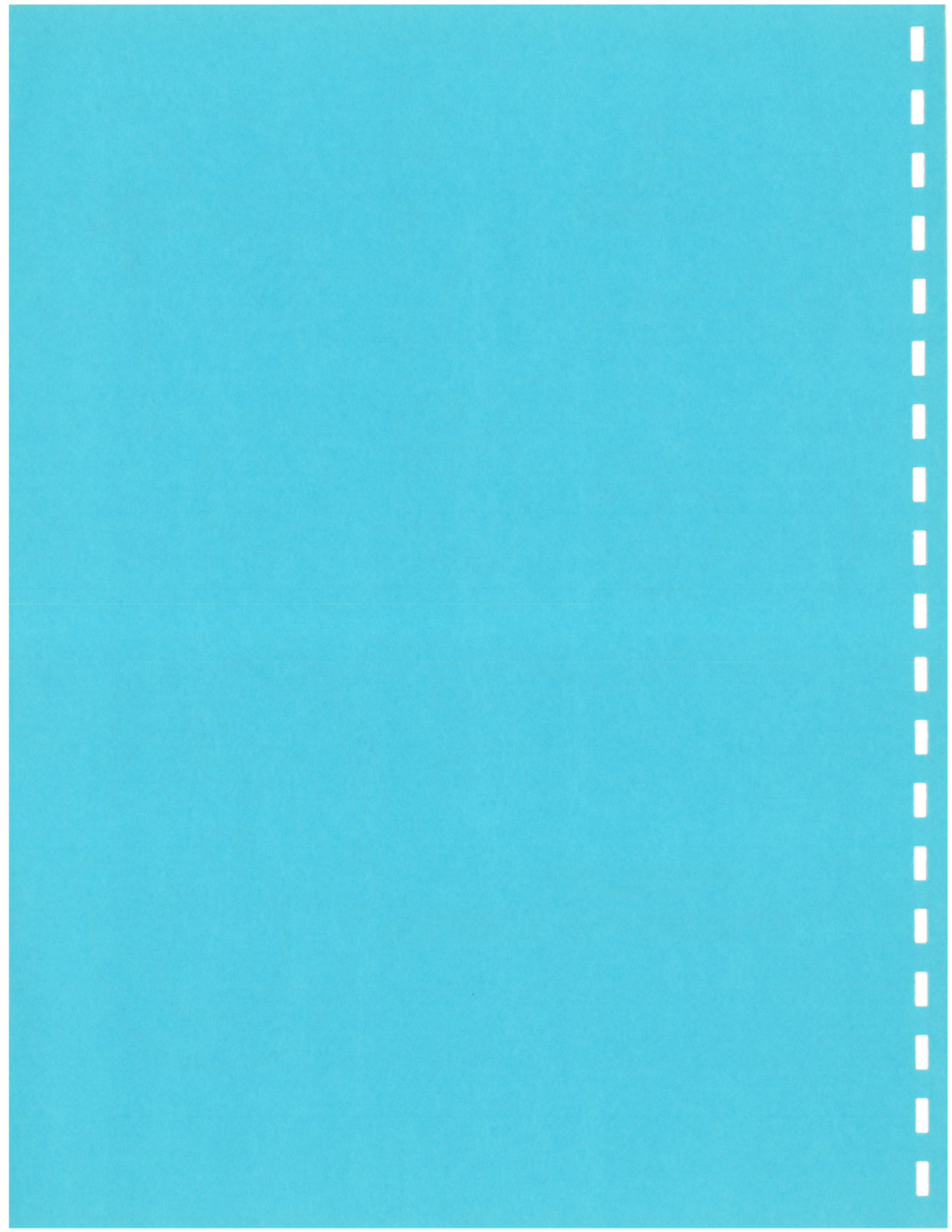

FEBRUARY STRONG FOR AMERICA

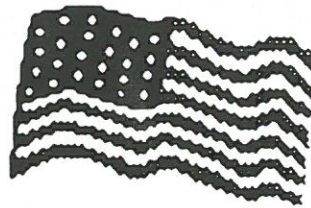

OPENINGS

I AM THE UNITED STATES

FROM: Calif. Parent teacher magazine feb. '61

I was born on July 4, 1776, and the Declaration of Independence is my birth certificate. The bloodlines of the world run in my veins, because I offered freedom to the oppressed. I am the United States.

I am the 180 million souls, and the ghost of millions who have lived and died for me.

I am Nathan Hale, and Paul Revere. I stood at Lexington and fired the shot heard around the world. I am Washington, Jefferson and Patrick Henry. I am John Paul Jones, the Green Mountain boys, and Davy Crockett. I am Lee, Grant, and Abe Lincoln.

I am the Brooklyn Bridge, the wheat lands of Kansas, and the granite hills of Vermont. I am the coal fields of the Virginias and Pennsylvania; the fertile lands of the West; the Golden Gate and the Grand Canyon. I am Independence Hall, the Monitor and the Merrimac.

I am big. I sprawl from the Atlantic to the Pacific, three million square miles throbbing with industry. I am more than five million farms. I am forrest, field, mountain and desert. I am quiet villages and cities that never sleep. You can see the lights of Christmas, and hear the strains of Auld Lag Syne as the calendar turns.

I am Babe Ruth and the World Series. I am 169,000 schools and colleges and 250,000 churches where people worship God as they think best. I am a ballot dropped in

a box; the roar of a crowd in a stadium, and the voice of a choir in a cathedral. I am an editorial in a newspaper, and a letter to a Congressman.

I am Eli Whitney and Stephen Foster. I am Tom Edison, Albert Einstein, and Billy Graham. I am Horace Greeley, Will Rogers, and the Wright brothers. I am George Washington Carver, Daniel Webster and Jonas Salk.

I am Longfellow, Harriet Beecher Stowe, Walt Whitman, Thomas Paine.

Yes I am the Nation, and these are the things that I am. I was conceived in freedom, and God willing, in freedom I will spend the rest of my days. May I possess always the integrity, the courage, and the strength to keep myself unshackled, to remain a citadel of freedom and a beacon of hope to the world.

I AM THE UNITED STATES

THE FLAG SPEAKS

"I am whatever you make me, nothing more. I am your belief in yourself, your dream of what a people may become—I am the day's work of the weakest man and the largest dream of the most daring—I am the clutch of an idea and the reasoned purpose of the resolution. I am no more than what you believe I can be. I am what you make me, nothing more"



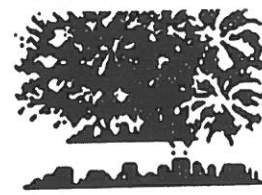

OPENINGS - CONT'D

ONE NATION UNDER GOD BY: DOUG KROLL

At the close of the solemn pledge to our flag, there is a small and simple phrase. Its words are often stated without much thought, but these words run deep into the founding and forging of our nation. The phrase is "ONE NATION UNDER GOD."

It is hard for us today to imagine the struggle and sacrifices our forefathers made. A driving force that compelled them to carry on was their deep faith in God and the close ties of their families.

We should all take time to reflect on our good fortune and appreciate that fact that we are a great nation, and God is watching over us. America can sustain liberty, justice and greatness forever, as long as she remains 'ONE NATION UNDER GOD.'

IN GOD WE TRUST BY: DOUG KROLL

Hold up a coin and point out that it like all of our coins, has on it the words: 'IN GOD WE TRUST'

Those words were added in 1861 when the Secretary of the Treasury wrote to the Director of the Mint the following words:

"No nation can be strong except in the strength of God, or safe except in His defense. The trust of our people in God should be declared on our national coins. Will you cause a device to be prepared without necessary delay with the motto expressing in the finest and tersest words possible, this national recognition."

Every time you look at a coin, may you be reminded that America's strength lies in our trust for God.

PATRIOTIC CEREMONY

FROM: San Diego Council

Staging: A Den of Cub Scouts advance flags in usual manner. After Pledge of Allegiance is given and flags are posted, the boys stand at attention in a straight line on stage. Each recites his part in turn.

1st Cub: I believe in America!

2nd Cub: I believe in this great land where freedom and opportunity are more than just words.

3rd Cub: I believe that we as a nation place our basic trust and hope in God.

4th Cub: I believe that despite all difficulties, we as Americans will continue to be a strong, God-fearing country.

5th Cub: I believe that as a nation we have our faults, but I also believe that we are trying to overcome them.

6th Cub: I believe in America!

7th Cub: Please join us in singing "America"

Note: Another Patriotic song can be used in its place.

OUR FLAG

FROM: Grossmont- San Diego

Props: Have one boy come out carrying the American flag. Then have seven boys come out carrying a card with one of the letters that spell out 'OUR FLAG' and then have each of the boys tell what his letter stands for.

O Only Flag for America

U Understanding for all Americans

R Rejoicing for our freedom

F Freedom for all

L Legions to God and Country

A Americans United for all

G Glory, Grace and Goodness

Everyone repeats the Pledge of Allegiance. (Can be used for closing.)



BADEN - POWELL CLOSING

This closing can be done by having boys recite one line each, or one person can read the entire piece.

Baden-Powell had a vision which he made come true,

So that we enjoy Scouting and have fun while we do.

He wasn't an American but he's famous to us

He has earned in America our admiration and trust.

May the Spirit of Scouting be with both young and old,

As we never forget the Blue and the Gold.

May you strive for Truth and Spirituality in the warm sunlight under the sky above.

May you bring Good Cheer and Happiness to others and have steadfast Loyalty and Love.

GAME

CIRCLE KNOT RACE MONTEREY COUNCIL

The first step of this game is to teach the players how to tie a square knot. Each person is given a short length of line. A leader at each table teaches the team (those around one table) to tie the knot. Leaders help until everyone knows how to tie the knot.

Next, each team joins hands and holds them high until on a given signal the leader ties his line to the person at his right, and so on around the table until the completed line again reaches the leader, who completes the circle of the line. He then says, "finished" and holds the line up so all can see, others around the table do the same thing saying finished in turn and raising the line up high. The

first team to finish with all knots tied correctly is declared the winner.

BLUE AND GOLD

During the month of February all scouts celebrate the anniversary and birth of Scouting.

Cub Scouts usually have a dinner and honor the leaders and other adults that have served the Pack during the year and prior.

Please refer to your Program Helps and How To Book for crafts and additional information. Listed below are some ideas for your program.

BLUE AND GOLD OPENING

PROPS: On head table are arranged magic candles (instructions below) which should be lighted as ceremony begins.

NARRATOR: Our candle stands tall straight and white. It burns and gives forth inspiring light. As its light shines forth, you will see our colors blue and gold are regal as can be. As the blue appears, think of truth and loyalty, the sky so blue, steadfastness and spirituality. When the gold shines forth, be of good cheer and think of happiness and the sunlight so clear. As our candles flame reaches toward the sky so blue, let us ask the Lord to give wisdom to lead each boy straight and true. Mold each of us to be like our candles, straight and tall and be inspired to give to God and our country our all.

HOW TO MAKE MAGIC CANDLES
Use a tall white candle. Drill 1/4" diameter holes every two inches down opposite sides of the candle.

CONTINUED PAGE 4

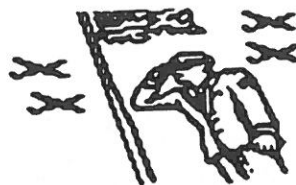

MAGIC CANDLES CONT'D

Place scrapings of blue and gold crayons in the holes. Melt paraffin and whip with egg beater. Cover candle with whipped paraffin using a fork to give the candle a rough decoration. As the white candle burns, it will drip wax decoratively down the side of the candle.

BLUE & GOLD CLOSING

Everyone is given a birthday candle or a cupcake with a candle.

CUEMASTER: Did you know that over 36 million boys and men have been a part of the Boy Scout movement since its beginning in 1910? Many of you dads were Scouts and today your sons are Cub Scouts. What a vast force to be crusading each day, at work or play for those things America holds dear. As we light the candles on our birthday cake, over all is the Spirit of Scouting. Let us resolve that as someone, somewhere helped us get started in Cub Scouting, we will together and as individuals, help more boys and institutions have Cub Scouting.

Repeat with me the response to our Cub Scout Motto:
"We'll Do Our Best". Now let's sing Happy Birthday.

CLOSING

BLESS THESE SCOUTS Columbia Council

*Bless these Scouts, O Lord,
we pray
Keep them healthy, in every
way
Let them know their Cub
Scout sign,*

CLOSING CONT'D

*And have it always on their
mind
For if they do we promise
them,
They'll become good future
men.
Hear their prayers, night
and day
Guide them, Lord along their
way.
Bless these Cubs and leaders
too;
Always, keep them close to
you.*

DENNER INDUCTION AND RETIREMENT

DEN LEADER: Will ___ (retiring Denner) ___ please step forward. You have been Denner of Den# ___ for the past ___ month(s)(weeks). I would like to thank you for your help. (shake hands). Now as your final duty as Denner will you install the new denner?

OLD DENNER: Will ___ (new Denner) ___ please come forward, ___ name ___ do you accept the position of Denner of Den # ___?

NEW DENNER: Yes

OLD DENNER: As Denner you will help the Den Leader whenever possible. You will arrive early to help with last minute preparations for the Den Meeting. You will stay after the meeting to help with putting supplies away. You will sometimes lead songs, games yells and other duties assigned by the Den Leader. You will be responsible for our Den Flag at Pack meetings. Do you accept these duties?

NEW DENNER: Yes

OLD DENNER: Let me congratulate you and present you with the Den Flag and your badge of office. (Or your badge of office is presented at the next Pack meeting)(Shake hands)



SKITS

BLUE AND GOLD MONTEREY COUNCIL

This skit can be adjusted to suite various occasions. Boys may make the props and thereby earn credit toward an achievement or elective.

The narrator, the "SPIRIT OF LORD BADEN POWELL" can be the Den Chief in full uniform wearing a campaigning hat. He reads the entire script from a lecturn.

NARRATOR:

I represent the spirit of Lord Baden Powell, the founder of Boy Scouting. I am also the spirit of Scouting past and present. Here is our future—Cub Scouts of America.

(First boy enters carrying a toy church or Bible, Narrator continues)

We take turns praying in our dens. I like to wear my uniform to church on Scout Sunday. Nearly half of all Cub Scout packs in America are sponsored by churches.

(Second boy approaches in complete Cub Scout uniform. Narrator continues) The two colors of the Cub Scout uniform have a meaning. Blue stands for truth and loyalty; gold for cheer and happiness.

(Third boy enters carrying Wolf Cub Scout Book and Kipling's jungle book.) Early Cub Scout ceremonies were based on Kipling's jungle tales. When Cub Scouting was organized in America in 1929, Indian themes were used.

(Fourth boy enters with a craft project of wood.) Cubbing means fun. We have lost of fun. But I like making things—real boy projects—things we can use, play

with or that follow our theme.

(Fifth boy carries in a nature collection.) I like to go on hikes and collect things for my nature collection of the den museum.

(Sixth boy enters with a buddy burner.) I like to go on picnics. We Cub Scouts sure do like to eat. This is a cook stove I made.

(Seventh boy, the smallest Cub Scout, enters with American Flag.)

I am proud to be an American so I can salute our flag. I also like to see our pack flag because then I know I am part of the ___years of Scouting I belong.

Yes, I represent the past and the present. These Cub Scouts are the men of tomorrow. They will be the preservers of our American heritage.

FREEDOM - OPENING OR CLOSING

Staging: After flags are advanced in usual manner and Pledge of Allegiance is repeated, A Cub Scout reads the following:

Freedom is a breath of air,
Pine-scented, or salty like the sea;
Freedom is a field new-plowed
With furrows of democracy.

Freedom is a forest,
Trees tall and straight as men!
Freedom is a printing press,
The power of the pen!

Freedom is a country church,
A cathedral's stately spire:
Freedom is a spirit
That can set the heart on fire!

Freedom is a man's birthright.
A Sacred, living part:

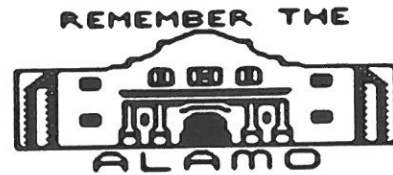

FREEDOM CONTINUED

A pulse beat of humanity.
The throb of a nation's heart!

DEN LEADER RECOGNITION

MATERIALS: Appreciation certificates for each Den leader and Webelos Den Leaders.

CUBMASTER: There is something which parents sometimes overlook when they consider the possibility of serving as Den or Pack Leaders. There are two very different types of homes. In one type, everything will always be just so. The furniture is not likely to be marred; there will be little shouting or noise except from the boy who lives in that house; and even his shouting will be subdued and experimental. His mother will seldom be troubled by the shouts of other boys, because it is not likely that they will come there. And unless something unusual happens, that is the type of home it will always be. As the children who live in it become young men and women, the rug will never be rolled up for social occasions. They will take their noise and laughter where it is better understood and more welcome.

But there's another type of home. This type attracts the friends of the children who live in it. They would rather bring their friends there than join them elsewhere. It is a home where children are welcome, where they learn to take care of the furniture rather than preserve it through lack of use. It's a home which later will attract young people.

It's true - the first type of house

will be peaceful, because it will be empty. Too empty - too peaceful - to quiet.

But there are more wonderful things to be sought after in life than peace and quiet. And besides, if you live in the second type of home. It does not mean that all of your own personal comforts and pleasures must be sacrificed. Lasting satisfaction comes from the knowledge that as each day goes by, you are guaranteeing your children's future memories of their home will be happy ones.

Most Den Leaders want the second type of home, and they have started to build now, because in a year or two it will be too late. That's why Cub Scouting is not all giving on their part. They'll receive a finer home life and stronger family because of it.

(Call forward Den Leaders for presentation of certificates)

These people are making one of the finest possible contributions to our community by serving as Den Leaders. They not only deal with boys, but with parents too. They are strengthening the life of our community by enriching the lives of the families who live in it. They are teaching boys to respect their homes and their parents, and they are helping parents understand their boys better by doing things with them. Few community services are more important than this.

Please accept these certificates as a small token of our gratitude for your help in Cub Scouting, and the thanks of all the boys you are helping by your service. Thank you.



**SONGS
EATS**

*TUNE: Hail, Hail the Gang's
All Here*

Soup, soup we all want soup
Tip your bowl and drain it,
Let your whiskers strain it.
Hark, Hark that funny noise.
Listen to the gurgling boys.

Meat, meat bring on the meat,
Fresh and juicy cow meat,
Ham and pickled pigs' feet,
Lamb chops and pork chops too, Any
kind of meat will do.

Fish, fish we must have fish,
We don't want it bony,
Nor a little phony,
Fresh fish, we won't eat stale
Any kind of fish but whale!

BIRTHDAY B.S.A.

TUNE: On Top of Old Smokey

We were all at the banquet
On Blue and Gold Day
The whole family came there
To eat and to play.

Then somebody told me
We're () years old
I could not believe
What I had been told.

They they brought out a cake
With candles atop
I counted the candles
And I didn't stop

Then somebody told me
An astonishing fact,
That the Boys Scouts Of America
Is much older than that

My Den Leader told me
That I shouldn't fret
That's the age of Cub Scouting
I'm not that old yet.

BLUE AND GOLD

TUNE: This Old Man

****Refrain**

Blue and Gold, Blue and Gold
Cub Scout colors bright and bold

We'll all salute them ev'ry year
That's is why we're gathered here.

(Repeat Refrain)

Let's all join in and sing a happy
song:
This is where the Cub Scouts
Belong.

(Repeat Refrain)

We're proud to be Cub Scouts today
And to live the Scouting way.

**DEN CHIEF RECOGNITION
CERMONY**

GROSSMONT - SAN DIEGO

Personnel: Akela (Cubmaster), a Cub
Scout, new Den Chief and older Den
Chief and Den Leader

Equipment: Two 8 ft. lengths of
rope made of yarn, one blue and one
yellow, table, scroll and copy of Den
Chief's Handbook

Arrangement: Cub Scout stands on
Akela's right holding blue rope.
Other Den Chief stands on Akela's
left holding yellow rope. Book is on
the table.

Akela: Cub Scouts and friends of
Pack ____, we wish to recognize a
new leader who will serve as Den
Chief of Den # ____, I, Akela, Chief of
the Webelos pondered long into the
night who should lead the young
Cub Scouts of our pack. An
important council Chief of our older
brothers, to choose this important
leader. Now, we call to our council

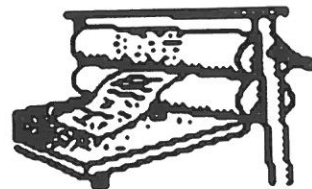

DEN CHIEF RECOGNITION - CONT'D

the chosen one, Scout _____ of Troop _____.

The blue rope (points to it) represents the Cub Scout Pack with all its boys, leaders and parents, and also the Cub Scout promise and the Law of the Pack.

The gold rope (points to it) represents the Boy Scout troop, its leaders, the Scout Oath and Law. You will notice the ropes are made of many strands, representing all the boys in the troop and pack. Let us now bind together these ropes into a bond of friendship. (The Cub Scout and the older Den Chief each grasp an end of the two cords and twist them in opposite directions). Now you can see that these ropes represent the Den Chief's badge of office, the Den Chief's cord. Notice that our new Den Chief is wearing this shoulder cord encircling his right sleeve. This was presented to him in his troop in recognition of his new position.

And now (speaking to new Den Chief) in recognition of your high office, we of the pack would like to present you this Den Chief's denbook.

When Akela was a boy, he was taken on trips by his Chief to learn the ways of the braves to prepare him for the day when he would become the chief. You have now become a chief in Akela's pack to lead the younger ones so that they shall become mighty hunters and honorable Webelos. Your Den Leader will be with you to lead the Cub Scouts of your den along the Cub Scouting trail. Mr/Mrs. (Name of Den Leader) will you come stand beside your new Den Chief as we

give him the Grand Howl of Welcome.

(The den or Pack gives the Grand Howl. All return to their places. Den Chief sits with his den.)

**REMEMBER TO SEE YOUR "HOW TO BOOK"
FOR INFORMATION ON THE BLUE AND GOLD BANQUET.**

Do not forget Scout Sunday this month.

Practice Flag folding in your dens.

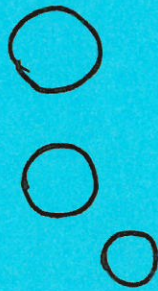
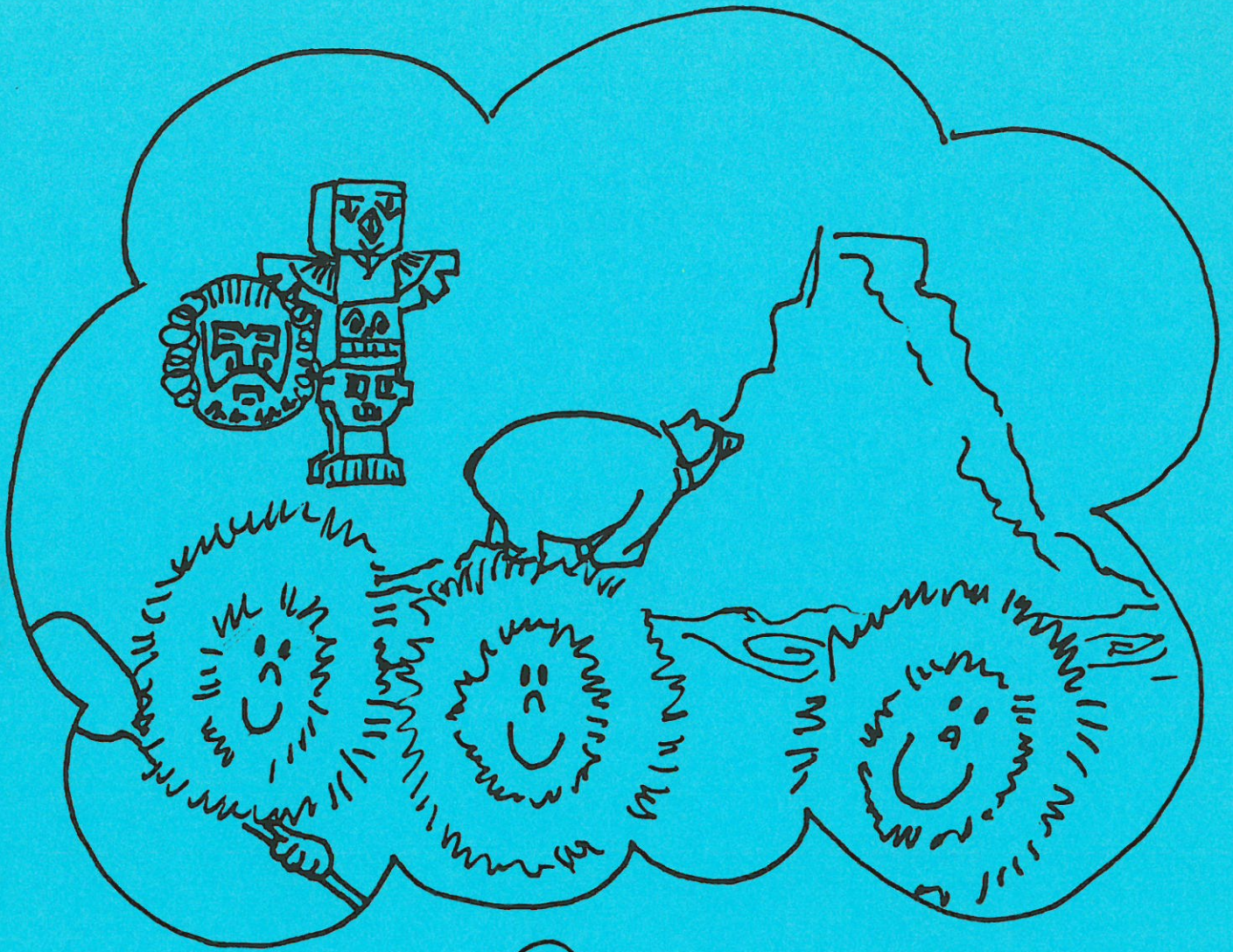

**MARCH
EXPLORING ALASKA**



MARCH EXPLORING ALASKA



ADVANCEMENT CEREMONY

PROPS: Artificial campfire, Akela costume, tom-tom

SETTING: Fire is glowing. Akela stands behind fire and is flanked by awards chairman and Assistant Cubmaster who beats tom-tom

AKELA: Will all Cub Scouts in good standing with this tribe come forward and be seated around the council fire. It is time for us to take council.

(Cub Scouts come forward and are seated)

Our Medicine Man (Awards Chairman) is here, so it is time for the Council to begin.

(tom-tom beats)

Mighty Medicine Man, you have signalled us that some of the braves in this tribe have traveled along the Trail of the Golden Arrow of Light far enough to earn them names of their hunting stations. Who are these braves?

AWARDS CHAIRMAN: (READS NAMES OF BOYS TO RECEIVE AWARDS)

AKELA: Mighty Warrior, how far along this trail did these braves travel?

AWARDS CHAIRMAN: (Name of Boy) has passed the twelve achievement tests of Wolf Valley and also did a fine job of hunting for he earned a Gold Arrow. (Name) after crossing Bear Ridge, hunted well to earn a gold arrow

and a silver arrow. (Name) and (Name) are working their way up the Webelos Peak and have earned activity badges in _____ and _____.

AKELA: This is indeed a fine job of Scouting. Will these braves come forward and stand before the council fire so we can see these good hunters.

AWARDS CHAIRMAN: (to boys) Can you truthfully say you have followed the Cub Scout Promise and have tried to Do Your Best?

CUBS: Yes

AKELA: Will each of you tell us of one of your accomplishments along the trail? (Each boy Tells of one achievement of elective)

Awards are presented.

SONG

SHENANDOAH
(SING SLOWLY)

Oh, Shenandoah, I long to hear you
Way, Hey, you rolling river!
Oh Shenandoah, I long to hear you,
Way, Hey, we're bound awau
"Cross the wide Missouri

Oh, Shenandoah, I love your
daughter,
Way, Hey, you rolling river!
Oh, Shenandoah, I love your
daughter,
Way, Hey we're bound away
"Cross the wide Missouri

SHENANDOAH - SEE NEXT PAGE

PAGE 2 MARCH EXPLORING ALASKA

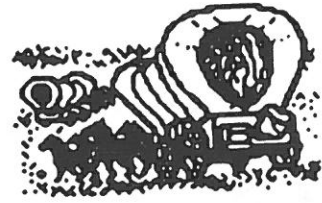

SHENANDOAH - CONT'D

Oh, Shenandoah, I'm bound to leave
you,
Way Hey, you rolling River!
Oh, Shenandoah, I'll not deceive you,
Way Hey, we're bound away
"Cross the Wide Miaasouri

HIKING SONG TUNE: Caisson Song

Over Hill over dale,
We will hit the Cub Scout trail,
As the Cub Scouts fo hiking along.

In and out, all around
You will never see us frown,
As the Cub Scouts go hiking along

And it's hi, hi, hee,
The Cub Scouts are for me
Shout out our name and shout it
strong
Wher'e we go, we will always
know
That the Cub Scouts fo hiking along.



CRAFTS

MY 'HANDY'WORK

BY: Norma Bergman

Maertials:

- 6" x 6" tagboard or poster board
- 1 Clothespin
- sticker stars
- 2" magnetic tape
- markers

1. Trace your hand on to the tagboard.
2. Cut it out.
3. Write your name and the word "handy work" on the palm of the cut out hand.
4. Draw smiley faces on the hand as shown.
5. stick on stars
6. Glue a clothespin to the back of the hand so that the closed end is at the bottom on the palm.
7. Glue magnetic tape to the clothespin.
8. Use this on the refrigerator to keep art work of school papers displayed.

Can also be used for notes by "Mom" and "Dad"

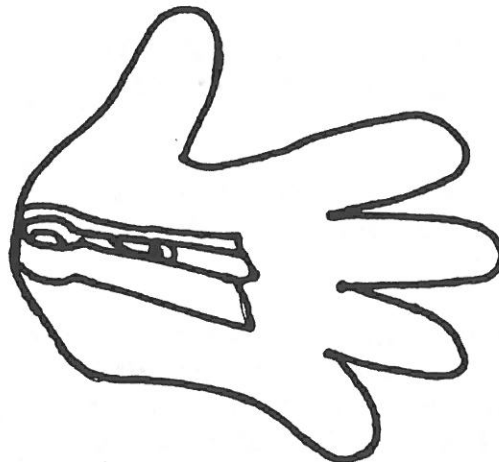



CRAFTS

ILLUMINATED COUNCIL FIRE

Cub Scout ceremonies are more dramatic when centered around an illuminated council fire in a darkened room. The effect can be very realistic.

MATERIALS: Birch logs
A few wood dowels
8" dia. cardboard carton (3 gal ice cream)
3/4" x 7-3/4" dia. wood disc
A surface outlet
10" length of lamp cord and plug
2-1/3" and 3" finishing nails
2" x 16" shingle pieces
Aluminum foil

Log lengths and diameters are not critical, but the pile should taper in thickness and length. Build the fire so the logs can be dismantled for storage.

The bottom four layers are doweled together. The top three layers are nailed together with finishing nails. The shingles used for the tinder effect are not fastened in place permanently - but placed tepee fashion around the container.

Assemble and wire the lamp base. Insert it in the cardboard container which has been covered with aluminum foil. Build the log pile, doweling the joints. To locate dowel centers, drive a small brad in the lower log, then press the upper log over the brad to mark the center in it .. then bore holes.

Use a 60 to 100 watt red or orange bulb for illumination. A white bulb can be painted red or orange. The light will filter through the slots in the shingles. Add a few short lengths of 1/4" wide red and white crinkled ribbon to top of pile to create a flame-leaping effect. (Use flame-proof paper)

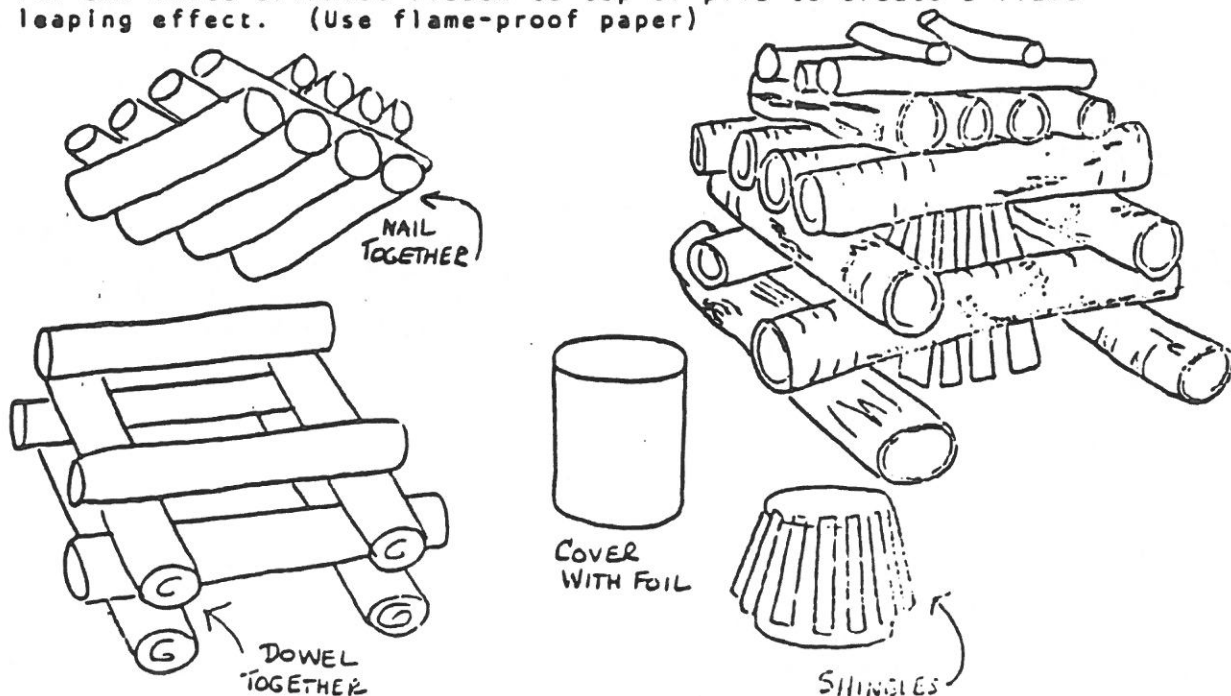

PAGE 4 MARCH EXPLORING ALASKA



CRAFTS

MAP MAKING

Group map making is an enjoyable project that can be carried out in several ways. Each child might make a different type of map of the same area, or the entire group can make a single large map.

Alaska, as illustrated below, offers an excellent subject for map making, since it is compact in area, has well-defined topographical features, a limited number of cities, railroads and highways and interesting products and natural resources.



POLITICAL MAPS

These maps can be outlined in ink and colored with crayon, colored pencils or water color. Indicate and label cities, rivers, roads and railways and other points of interest.

RELIEF MAPS

You will need a good relief or topographical map, such as you can find in encyclopedias or atlases. When building up topographical features, the elevations must be greatly exaggerated, otherwise the mountains would appear to be mere wrinkles. Make your map on heavy cardboard, corrugated cardboard, plywood or wallboard. Paint with poster paint and shellac.

**PAGE 5 MARCH
EXPLORING ALASKA**



CRAFTS

MINI BOX KITE

Materials: A piece of thin cardboard 8" x 9 1/4"
(half a file folder is okay)
Extra strong thread (carpet thread)
A sharp knife
Tape
Scissors
Pencil

Draw this pattern on your piece of thin cardboard.
Cut it out. Use a sharp knife to cut out the
three windows. Then fold the cardboard in
the three places indicated, just under the
windows. Run the edge of a ruler back
and forth over each fold to make a
sharp crease.

Now make the three-cornered box kite
by folding as shown in the diagram,
and taping the flap.

Loop the thread through the kite
and tie it like the bottom diagram
shows.

Put the pencil through the
thread spool so you can hold on to
it and let the thread unwind
easily.

This kite isn't very big so you
can fly it on the sidewalk or the
playground or the park. You can
even use it on your bike in
the neighborhood.

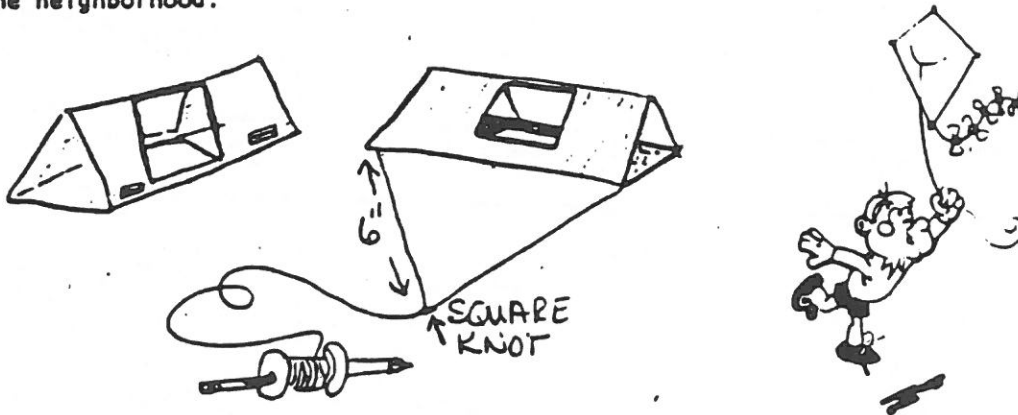
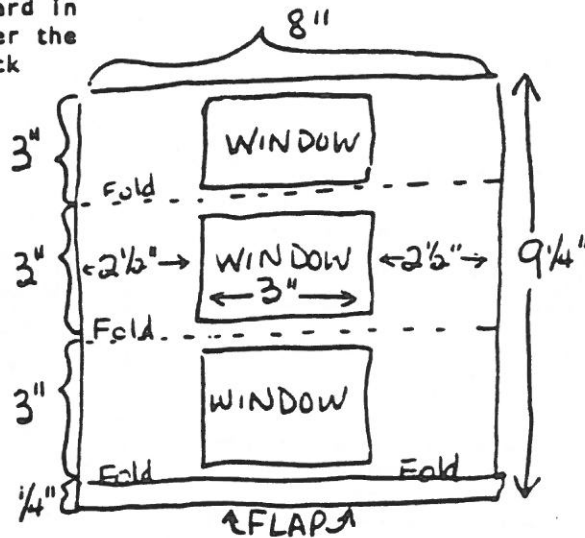



CRAFTS

EIGHT-POINTED STAR KITE

Materials needed:

Spars - square section hardwood
or softwood

Four spars 1/4" x 24"
Cover 26" x 26" made from
tissue paper, crepe paper
or lightweight cloth

Three tails - paper streamers
2" x 120" each

Line

Glue

Towing ring

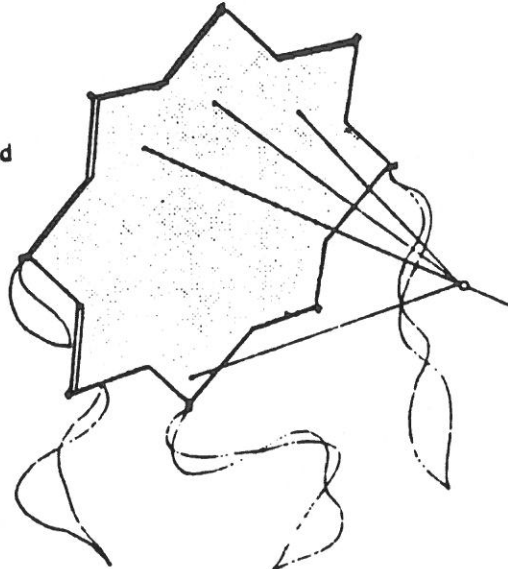

Conversions:
75cm = 30 in
60cm = 24 in
15cm = 6 in
5cm = 2 in

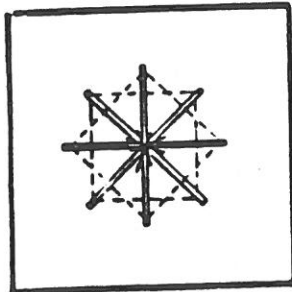

Structural form

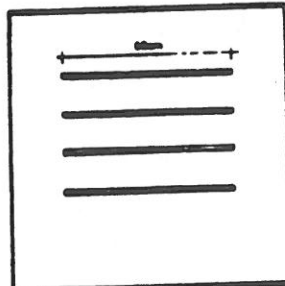

Measure spars carefully

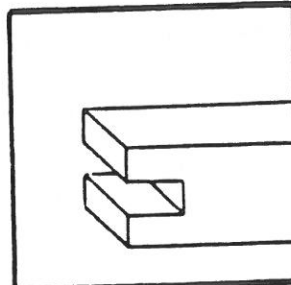

Notch ends of spars

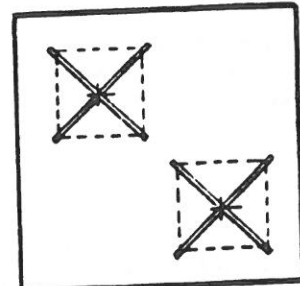

Tie spars together in pairs
and tie line round each pair

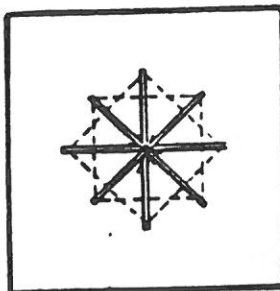

Tie pairs of spars together as
shown

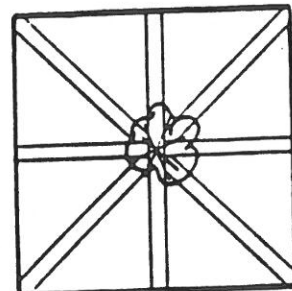

Fix centre joint securely with glue

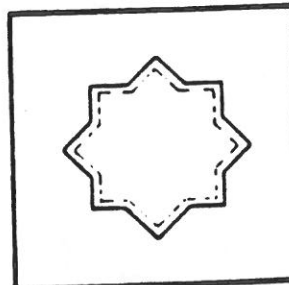

Cut out cover allowing hem all
round

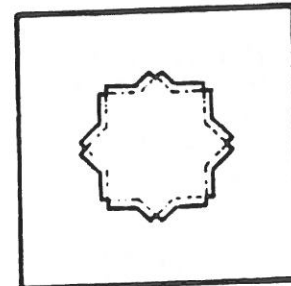

Nick corners of hem to allow
turning

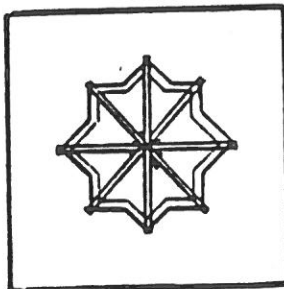

Attach cover to frame by turning
and gluing down hem

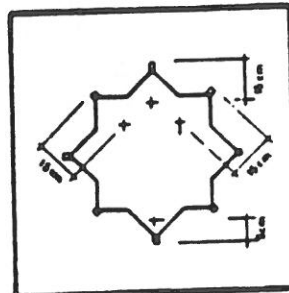

Mark 4 bridle points

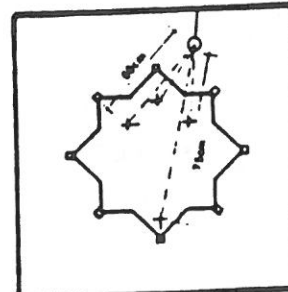

Fix 4-leg bridle. Top 3 legs of equal
length

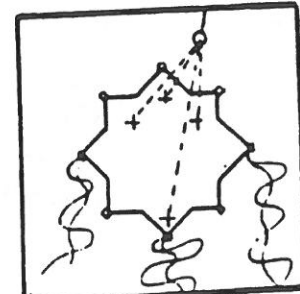

Attach 3 tails

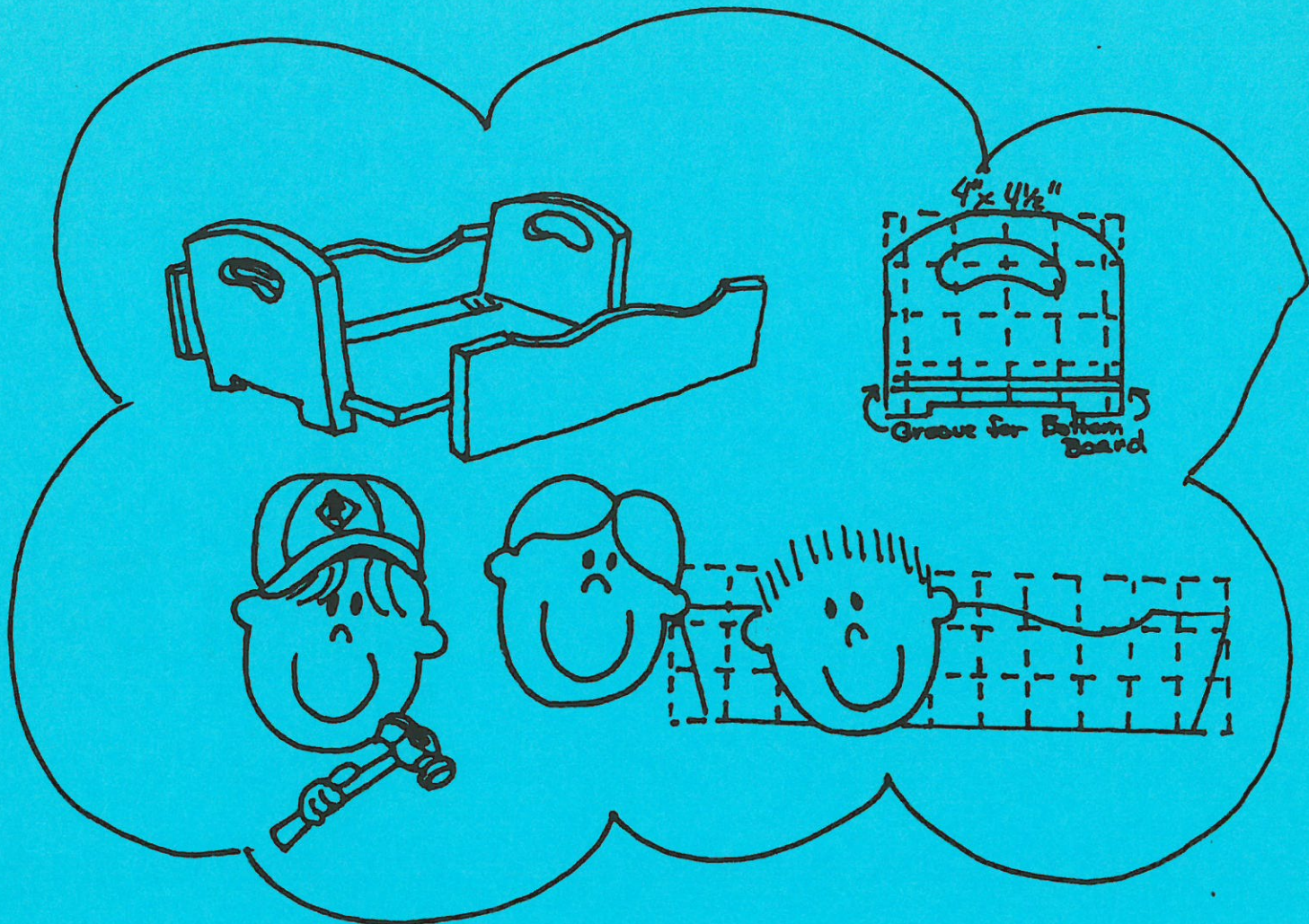

**APRIL
CUB SCOUT HANDYMAN**

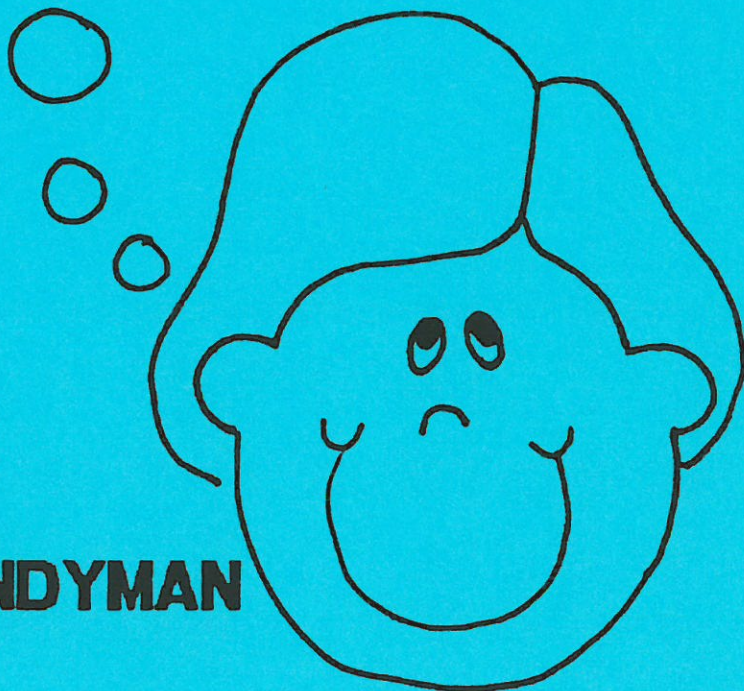

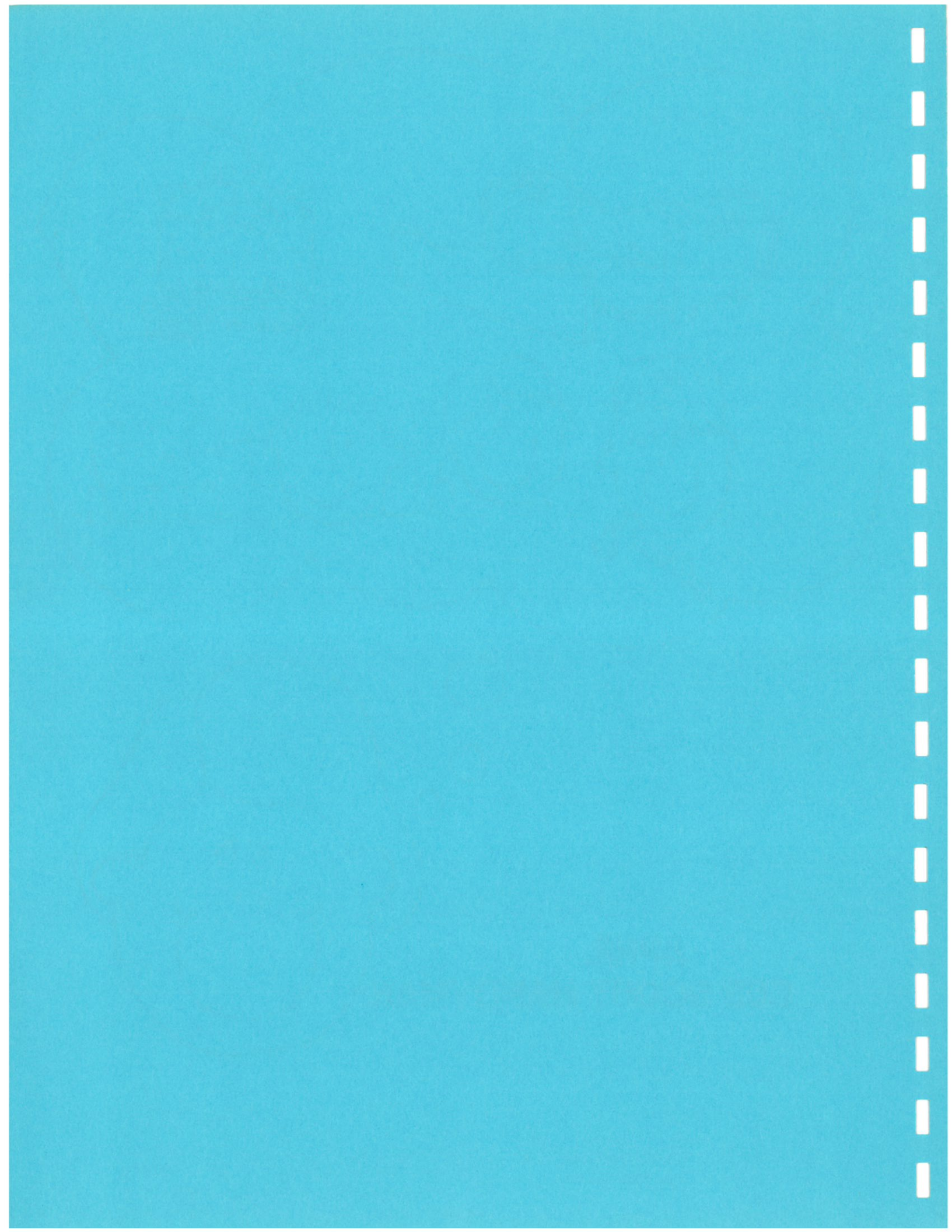

APRIL CUB SCOUT HANDYMAN



OPENING CEREMONY

GENIUS

Props: 7 boys, 6 holding cards, one acts as narrator

Narrator: This month the theme is Mr. Fix It and sometimes when we are called upon to fix something, you have to be a genius to figure it out. Here are some geniuses that we have learned about and what they have done for you.

- "G" Gutenberg invented moveable types of printing presses so that more people could have books to read.
- "E" Edison gave us the light bulb, the phonograph, storage batteries and many other things that we regard as necessities today.
- "N" Newton's studies of gravity and light started many other genius's on their way.
- "T" Irving's stories have enchanted young and old for years
- "U" Urey's discoveries in chemistry and nuclear power will be used for generations to come.
- "S" Scouting's founder Lord Baden-Powell, developed a plan for using the genius of every boy.

CLOSING CEREMONY

FIX IT

PROPS: 4 boys with pictures of the things they make or fix and the words on the back of the picture to describe it.

FIX IT - CONT'D

1st CUB: Everyone cannot be brilliant, everyone cannot be smart, I may not be a genius or a fixer, but I can build a neat go-cart.

2nd CUB: I can dam a stream with boulders, I can climb trees to the top. I can run for blocks and blocks and never even stop.

3rd CUB: I can't solve a chemical equation or lecture on Newton's rule. But I can make a peanut butter sandwich that will really make you drool.

4th CUB: I don't know much about flowers, but smelling them is a joy. I don't think I'm a failure. I'm a genius at being a boy.

OPENING CEREMONY CUB SCOUTING

PROPS: Each of 12 Cub Scouts holds a candle which is lighted as he gives his lines. Lights are out so room is in darkness. Cub Scouts are lined up on stage, side by side. As each boy's turn comes, he steps forward a few steps to say his lines, then steps back in place.

1st CUB: Cub Scout is a Boy. He is somewhere between 8 and 11 years old. He is just an average boy - energetic, inquisitive, noisy and eager to explore the world around him.

2nd CUB: Cub Scouting is PARENTS who love this boy and care about him. They want him to grow up to be a well-rounded individual who can live and work in an atmosphere of harmony and cooperation. SEE NEXT PAGE

PAGE 2 APRIL CUB SCOUT HANDYMAN



OPENING CEREMONY - CONT'D

3rd CUB: Cub Scouting is a Den Leader who opens the home and heart to this boy and 5, 6, or 7 others just like him so they may learn to do things in a group rather than individually and learn to share the limelight with others.

4th CUB: Cub Scouting is a DEN CHIEF - Boy Scout or Explorer who works into his busy schedule a time for the younger boy so he may encourage him to stay on the Scouting Trail for many years.

5th CUB: Cub Scouting is a Cubmaster who gives of his/her spare time and sometimes much more, to provide a program that will bring Cub Scouting to this boy.

6th CUB: Cub Scouting is a COMMITTEE made up of interested parents who back up the Cubmaster and who serve willingly to carry out Pack goals.

7th CUB: Cub Scouting is a NATIONWIDE ORGANIZATION, a little brother program to Scouting, provided by the Boy Scouts of America for the 8, 9 and 10 year old boy.

8th CUB: Cub Scouting is FUN for a boy, his parents and his leaders.

9th CUB: Cub Scouting is FELLOWSHIP with the boy in your class at school, your neighbor, and other people you might never meet except through Cub Scouting.

10th CUB: Cub Scouting is CITIZENSHIP - teaching the young boy respect for God and country.

He learns his moral obligation to himself and his fellow man.

11th CUB: Cub Scouting is a CHALLENGE to all who become involed - a challenge to live up to high ideals, bring forth creative ideas, express yourself. It is also a challenge to learn and accept the ideas of others who may not agree with you and learn to compromise and work out differences.

12th CUB: Cub Scouting is ACHIEVING by boys and parents as they work together on advancement in the boy's book. Leaders achieve as they carry out the Den and Pack programs successfully.

NARRATOR: As you can see, Cub Scouting is many things - each one important and shining forth in its own way. If we keep all these lights burning brightly in our Pack, our radiance will be seen by many people. This is Cub Scouting.

DEN LEADER INDUCTION

ARRANGEMENT: Committe Chairman and Cubmaster stand behind table in front of room. On table is a lighted candle and Den Leader's book.

COMMITTEE CHAIRMAN: The Den Leader occupies a unique and essential place in Cub Scouting. He/She fills a particular need for boys of Cub Scouting age and performs a fundamental service which no one else can give. He/She therefore, becomes a indispensable person in our scheme of operation. Mr/Mrs _(name)_ has been

PAGE 3 APRIL
CUB SCOUT HANDYMAN



DEN LEADER INDUCTION -
CONT'D

selected by the Pack Committee to serve as Den Leader for Den # _____. Mr./Mrs. _(name)_ will you please step forward.

Mr./Mrs. _(name)_ will you promise to:

1. Give concerned interest to the boys in your Den
2. Take advantage of all training opportunities
3. Be responsible for the organization and operation of the Den.
4. Lead the Den Chief, helping him use the Denner in activities of the Den.
5. Attend monthly Pack Leader's meeting, monthly Pack meeting and monthly District Roundtables.
6. Work with the parents of your Cub Scouts, so they will have the opportunity to share in the fun of Cub Scouting
7. Observe the policies of our chartered institution, of the Old Baldy Council and the National Council.
8. Keep your den in operation 12 month a year.

If so please answer "I will"(He/She does so)

CUBMASTER: Wearing the Den Leader's uniform not only identifies you as a very important member of the Boys Scouts of America, The largest boys' organization of its kind in the world . but it also sets a good example for the Cub Scouts in your Den.

We would like to welcome you as a new leader in our Pack and present you with the Den Leader's Den Book. Congratulations and good Cub Scouting. SONGS NEXT PAGE

SONGS

DO YOUR BEST
TUNE: Jingle Bells

Do your best, do your best
In everything you do
Keep the Promise and the Law
Be a Cub Scout True

Do your best, do your best
Be a loyal Scout
Do your duty to God
And help your country out.

DO YOUR BEST
TUNE: Reuben. Reuben

Do Your Best is the Cub Scout way
It will get you through each day
If you try it you will see
That it's the only way to be

TOOLS
TUNE: Row, Row, Row Your Boat

Hammer, nails, and a piece of tin
Pound it if you can
Bang, Bang fixed it all
Now you're a submarine

RESOURCES

This is the month to do different challenging crafts.
Tin Artwork(Hammer and nails)
Dot-to-Dot books make great patterns and are simple
How To Book
Program Helps
Roundtable
Visit a cabinet shop
Visit a Construction Site
Go for a walk in the forrest and find out about different tress and where wood comes from.



CRAFTS

WATER CLOCK

Who ever heard of an inch of time or a minute of water?
Here is a clock that measures them both.

MATERIALS: A straight-sided jar
A tin can (wide enough to sit on top of your jar)
Masking tape
A measuring cup
A ruler
A very thin nail and a hammer
A permanent Magic Marker

To make:

With the hammer and nail make a tiny hole in the bottom of the can. Draw a line with the Magic Marker around the inside of the can near the top. Pour water in up to the line.

Put a strip of masking tape up the side of the jar to make your calibrations on and set the can on top of the jar.

Watch a real clock and when the minute hand is at 12 pour water into the can up to the line. Make a mark on the tape at the water level for 1 minute, 2 minutes, etc.

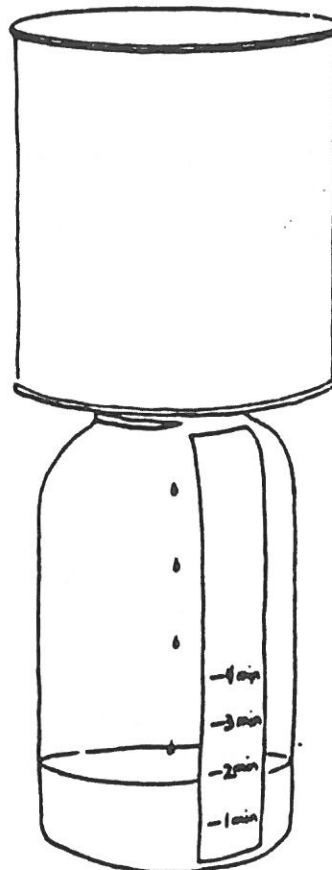
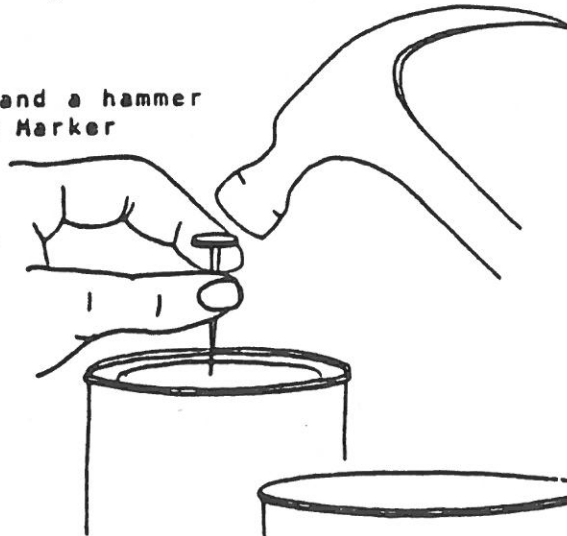



CRAFTS

A WEATHER VANE

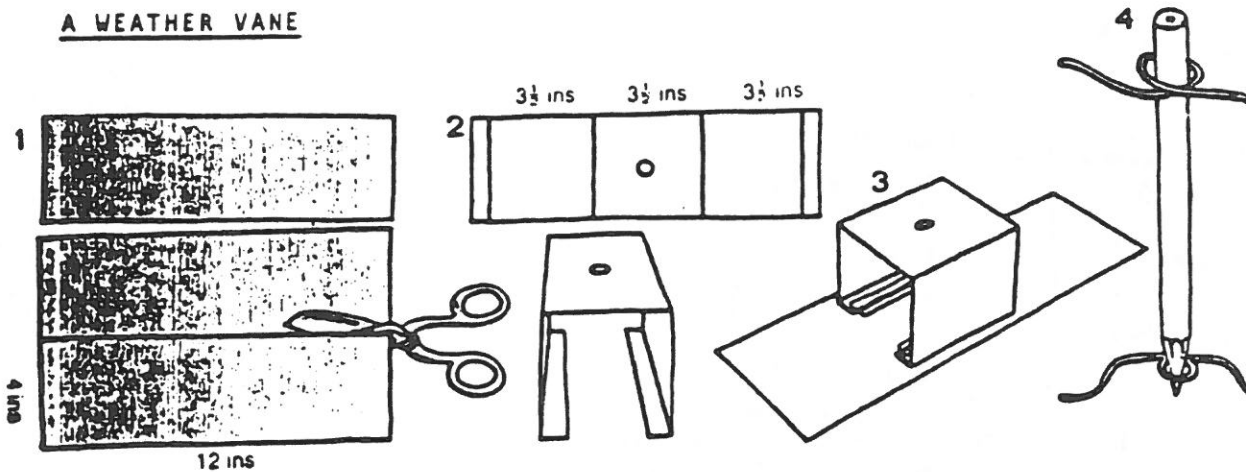

1. Use scissors to cut 3 pieces of cardboard, each 12" x 4".

2. With the tip of the scissors score across one piece of cardboard at the points shown. Make a hole in the middle with the scissors. Push a pencil through it until the hole is just a little bigger than the pencil. Bend the cardboard along the scored lines.

3. Use cellophane tape to fix the folded cardboard to one of the other pieces of cardboard. This is the stand for the weather vane. Now straighten two paper clips.

4. Wrap one paper clip loosely around the end of the pencil, and the other one loosely around the top of the pencil. Take the paper clips off the pencil.

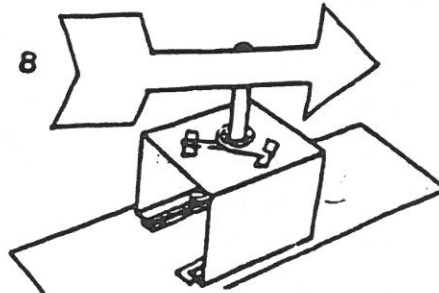
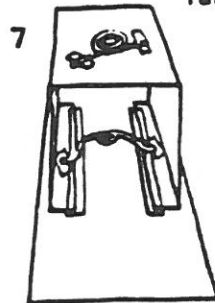
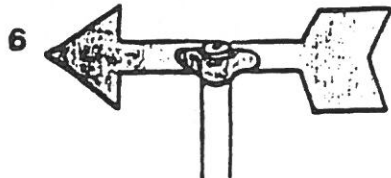
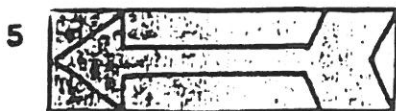

5. Draw an arrow, like the one shown, on the third piece of cardboard. Cut out the shape.

6. Use plasticine to fix the pencil to the center of the arrow. Make sure you use an equal amount of plasticine on both sides of the pencil, or the arrow won't balance properly.

7. Use cellophane tape to fix one paper clip over the hole in the stand. Fix the other one to the base, directly underneath. Stand the pencil in the hole.

8. Mark the points of the compass on the base. Outside, point the base so that "E" faces the direction of the rising sun. Record the direction of the wind for each day.

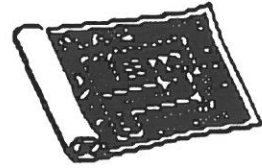

CRAFTS

JUMPER THUMPER

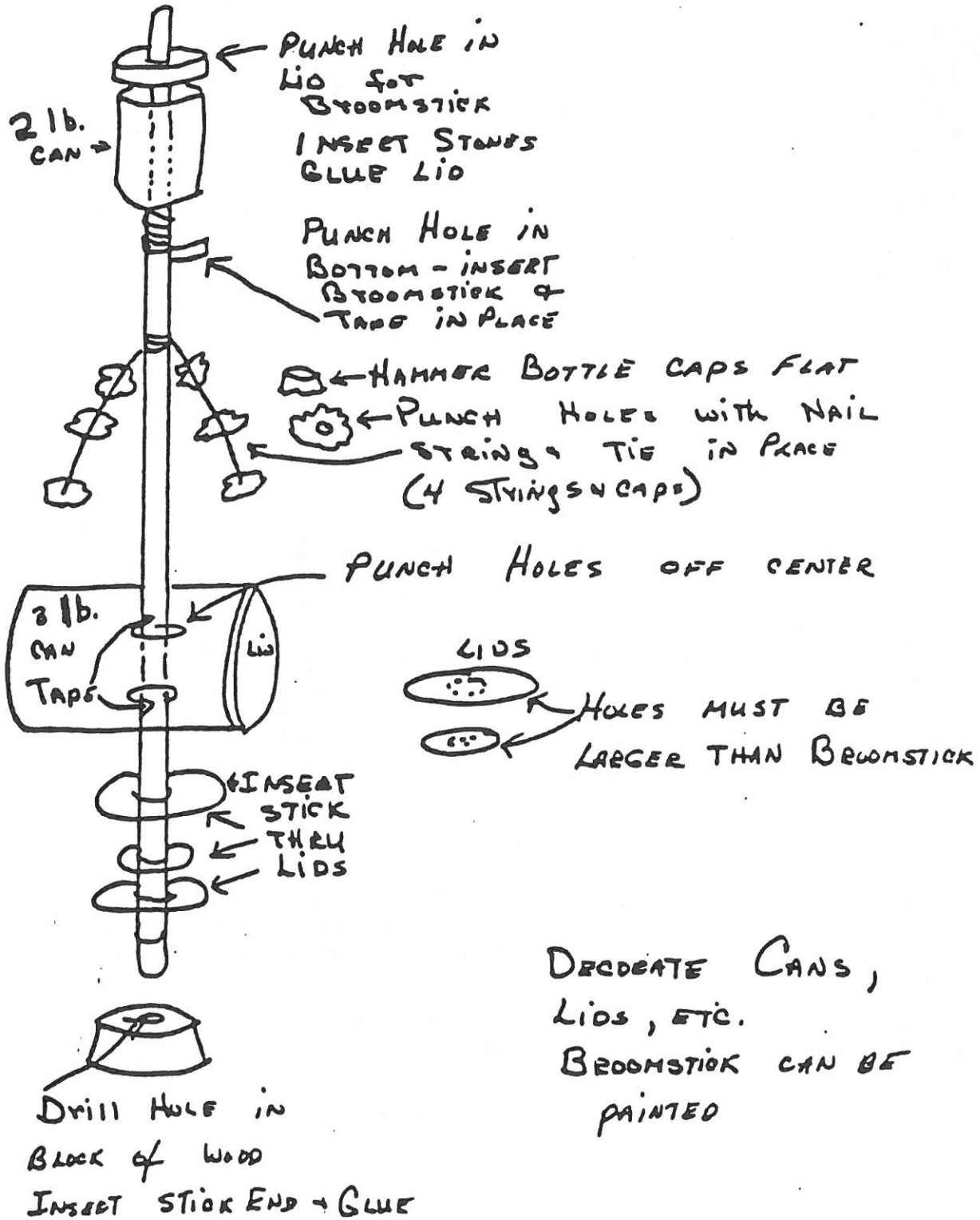



CRAFTS

DRUM: You will need a square gallon can, a tuna can, a 12" square of plywood, a wooden clip clothespin and a 9" dowel. Glue the tuna can to center bottom of square can. Next, remove one prong of the clothespin and nail dowel to the end, as shown. Reassemble clothespin and glue at center edge of one side of plywood. Pad end of dowel.

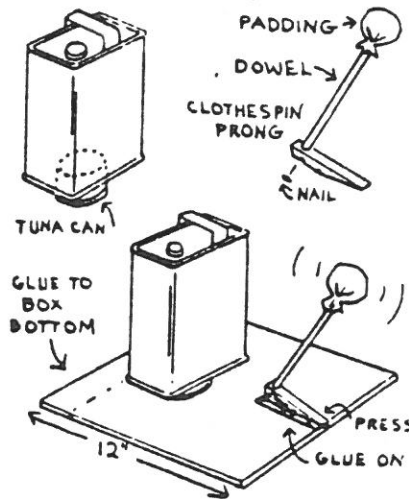

Next glue cans to wood base, placing them so side of square can almost touches padding on dowel. Let all dry thoroughly. To attach drum to carton, glue about 3" of the plywood to underside of the carton, being sure the drum doesn't touch side of carton.

HUMMER: Glue a long dowel or stick to center back of carton so the top reaches the mouth of a seated player. Wrap tissue paper loosely around a comb and tape it to the end of the dowel. (To use, place lips loosely against tissue and hum with the mouth open).

INSTRUCTIONS FOR PLAYING YOUR ONE MAN BAND - Player is seated at back with one foot near drum, one hand ready to pluck cello strings, the other holding stick to strike cymbals, the mouth in humming position and a knee ready to set the chimes to ringing.

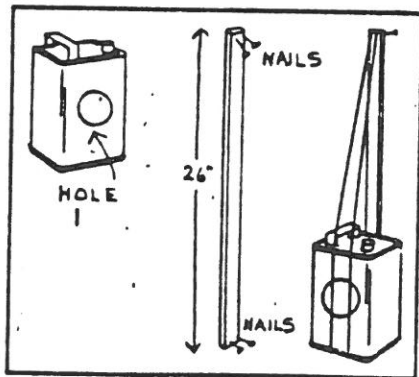

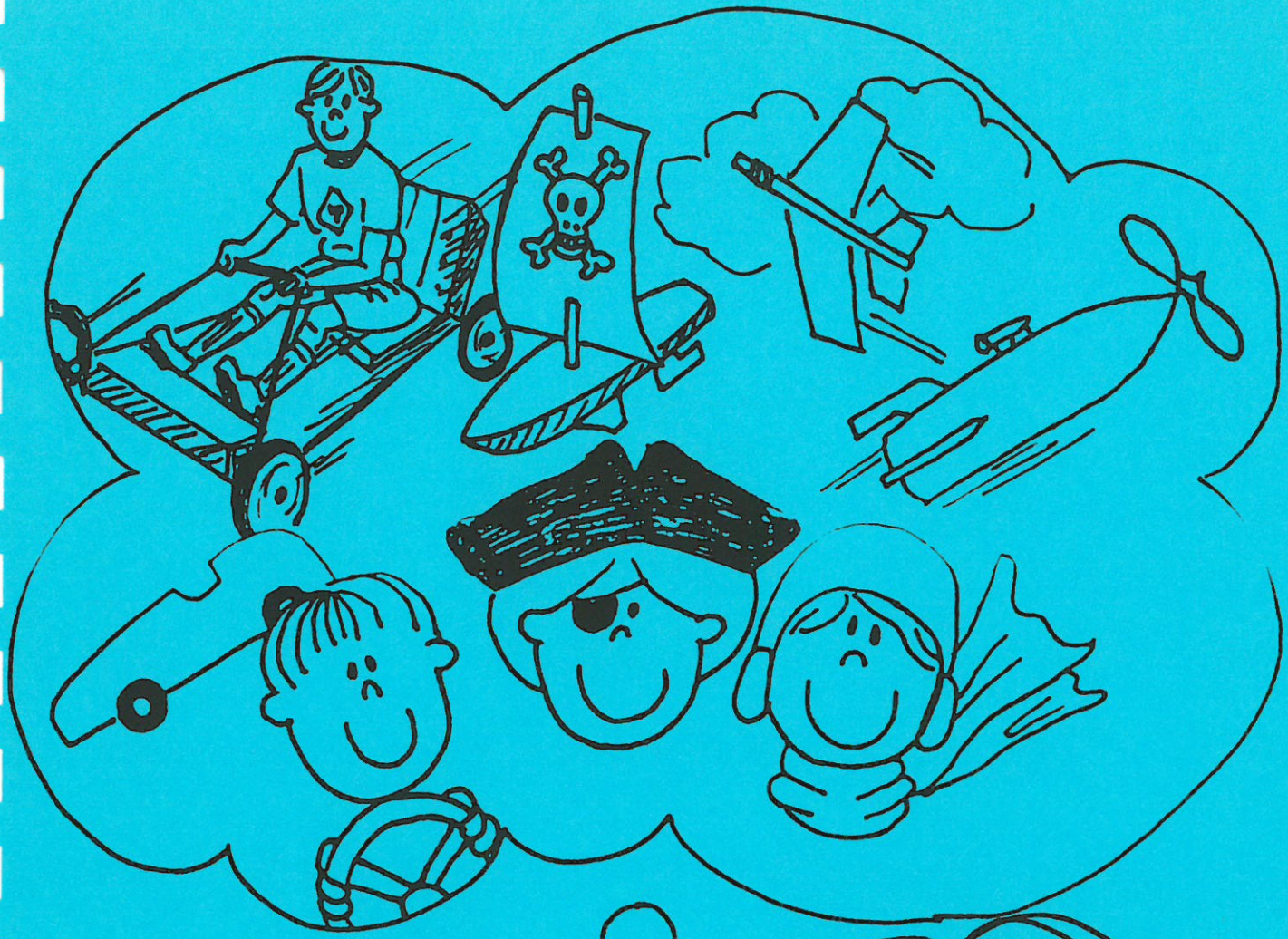

**MAY
WHEEL, WINGS
AND RUDDERS**



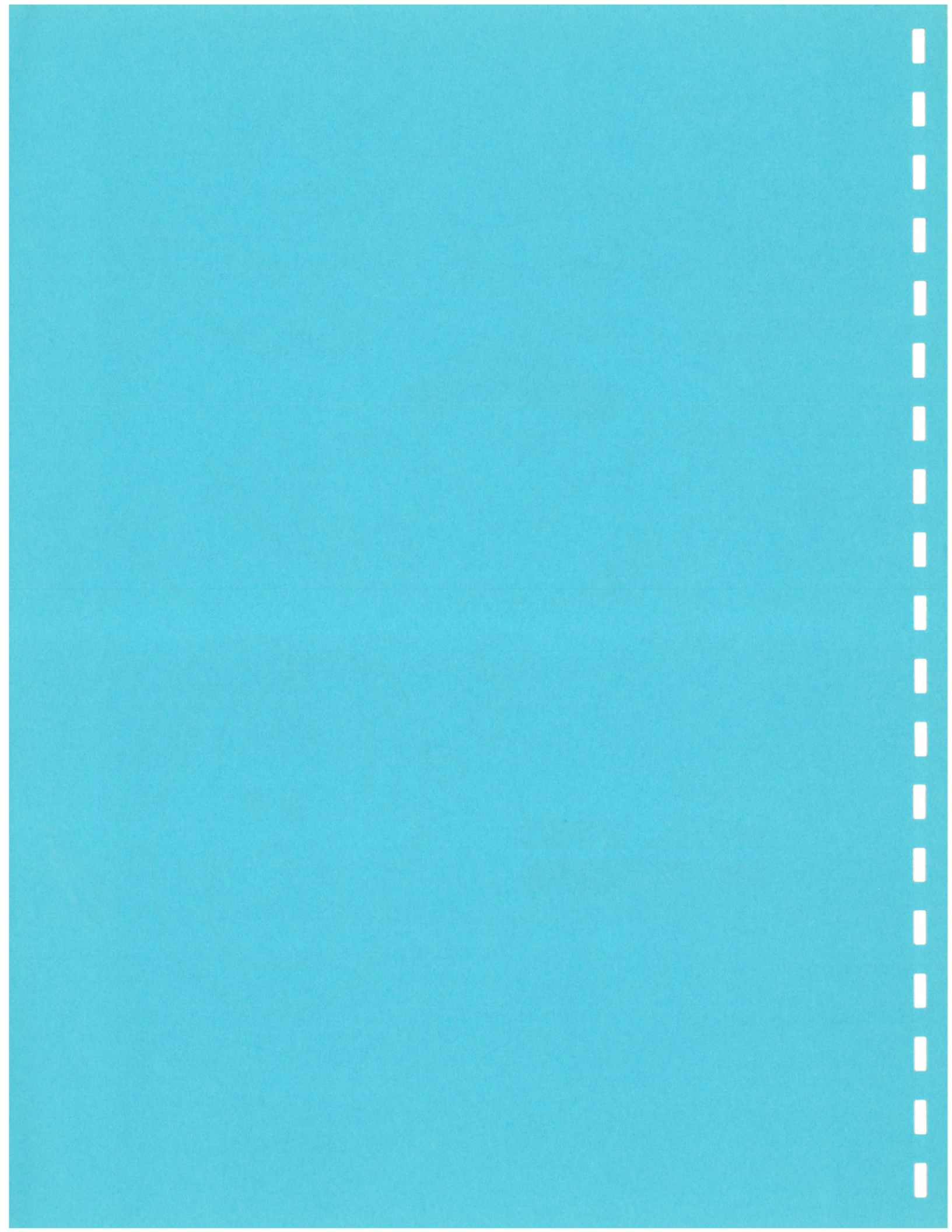

MAY WHEELS, WINGS AND RUDDERS



OPENING CEREMONY *San Diego Council*

Cub Scouts line up and hold their posters up as indicated below:

1st CUB: (word "GO") Wheels, wings and rudders make many things go,

2nd CUB: (Model-T Ford) Henry Ford was an important man, for he helped invent a car

3rd CUB: (Spirit of St. Louis plane) Lindberg was a man whom we've all read about, He helped build a plane that made the world all shout.

4th CUB: (Steamship) Robert Fulton did his part in making something that would go, The steamship made him famous about steam he sure did know.

5th CUB: (Steam Engine) James Watt, too became famous, for something that would go, His improvement on the steam engine, year after year did grow.

6th CUB: (Large wheel with the word 'THANKS' for spoke) So you see men such as these, make our country grow, And we're thankful to them, for inventing things that go.

7th CUB: (U. S. Map) So, as we're thinking about the men who have made our nation go, Let us now salute the flag, ever thankful for all that we know.

8th CUB: Will the audience please rise. Those in uniform, salute.

Those not in uniform, place your hand over your heart. Please join me in the Pledge of Allegiance.

OPENING CEREMONY CARS

PROPS: Narrator reads the lines below while 6 Cub Scouts one by one come on stage carrying cardboard models of the cars they represent - or large posters showing pictures of the cars.

NARRATOR: The favorite transportation in America, we feel, is Henry Ford's invention, the automobile. We all have our favorites, that you will know as we show you our cars - and now on with the show!

TOYOTA: I'm a Toyota, oh so small
Wind me up and I can crawl
Drive me out to the end of town
Then pick me up and turn me around

CADILLAC: I'm a shiny Cadillac
Driving to the store and back
I can purr so quietly
You can sleep while riding in me.

V.W.: I'm a little V.W. bug
So loveable . just give me a hug;
Drive me up the hill so slow
Then down the other side I'll go.

DODGE: I'm a Dodge with lots of class
Built for many a lad and lass,
I can go most any place,
And I hold my own in

**PAGE 2 MAY
WHEELS, WINGS AND RUDDERS**



CAR OPENING CONT'D

any race.

OLDSMOBILE: The merry Oldsmobile
I'm called
With all the latest, I'm
installed
Shiny things are here
and there
So you can drive me
anywhere.

CHEVROLET: I'm a Chevy, plain and
neat
I have a very comfy
seat
I'll perform for all who
ask
Doing every little task

**ADVANCEMENT CEREMONY
RAILROAD**

Prior to the Pack Meeting, issue train tickets to boys who will receive Wolf and Bear badges and Arrow Points.

Indicate on ticket the boy's name and the "car" he will be traveling on (Wolf, Bear, etc.) Use large cardboard cutouts representing various cars of train. Cubmaster acts as conductor. Den leaders carry the cutout cars, the train proceeds around the room and stops at each Den, where the Cubmaster exchanges the appropriate award for the ticket.

The Cub Scout receiving the award "boards the train" by getting in line behind the appropriate car. Webelos Scouts who are joining the Webelos Den ride the train to the Webelos Den stop, where they get off.

**SEE NEXT COLUMN FOR
Pass for Railroad .**

**RAILROAD ADVANCEMENT
CONTINUED
CUB RAILROAD**

PASSENGER ___ (Name of boy) ___

CAR ___ (Name of Award rec'd ___

POINT OF DEPARTURE ___ (Den #) ___

DESTINATION ___ (Next Rank) ___

FARE ___ (Either 12 achievements or
electives) _____

ADVANCEMENT CEREMONY

Props: Large pictures/posters of car, tugboat (steamship), airplane and a rocket.

CUBMASTER: The boys in our pack have not just been spinning their wheels and not going any place. We'll see tonight how many of them are reaching their destination.

Our Bobcats have really been "wheeling along" (picture of a car) and learning the "rules of the road". Will ___ and their parents wheel on up here and receive your Bobcat license that will keep you on the Cub Scout road?

"Chugging along" (picture of tugboat) as far as the current could carry them are the Wolves. Some of them tonight are ready to pull in at the Wolf dock. (Have boys and their parents "tie up" at the Wolf dock for their Wolf Rank.)

We also have some Wolves who are really loading up and have earned some Gold and Silver Arrows. (Call boys and their parents forward.)

PAGE 3 MAY WHEELS, WINGS AND RUDDERS

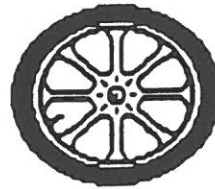

ADVANCEMENT CEREMONY CONTINUED

Not to be outdone, is our Bears who are really "flying High"(picture of airplane) this month. Some have landed right on target and earned their Bear. Will _____ and their parents set their wheels down up here and receive their pilot's license to continue flying the B.E.A.R.?

The following boys have taken an extra flight or two and earned their Gold and Silver Arrows(Call boys forward)

Our Webelos have "blasted off" this month (picture of a rocket) They have been traveling around working on Name of Badge. Let's have them come up here and tell us the exciting places they have been this month.

The "final frontier" that all of you boys would someday like to explore has been reached by a few of our Webelos Scouts tonight—that of the Arrow of Light. This is the farthest and highest that any one can go in Cub Scouting. (Call boys and their parents forward to receive their Arrow of Light)

CLOSING CEREMONY

Cub Scouts hold large cutouts as they read their lines off the back.

1st CUB: (holding train engine)
When engineering a project, keep on the right track. This way you never will be caught slack.

2nd CUB: (holding covered wagon)
The covered wagon served folks well it its day. But don't get in a rut — you won't go far that way.

3rd CUB: (holding plane) To guide your life, like a good pilot you'll find, it's important to keep an open mind.

4th CUB: (Holding car) If spinning your wheels causes a terrible rumbling, you may not be moving, but just sitting there grumbling,

5th CUB: (Holding space ship)
Just as an astronaut files into space, with alot of determination you can go any place.

6th CUB: (Holding "GO" sign) We do our best to help the pack "go" while having Cub Scout fun.

7th CUB: (Meandering trail) And when it's time to part and each take a separate trail, we'll do our best for God and country, in that we will not fail,

8th CUB: (Cub Scout sign) We remember our Cub Scout Promise in everything we do, won't you all please join as we pledge ourselves anew.

Everyone stands and gives the Cub the Cub Scout sign and Promise

OR

(ALTERNATE CLOSING FOR
CEREMONY)

(Cub Scouts prop sutouts against back wall, and join hands in a Living Circle while the Den Chief reads the following:)

Just like the cars in a train
We're joined together as one;
We do our best to help the Pack go,
While having Cub Scout fun.
And when it's time to part and each take a separate trail,
We'll do our best for God and country, in that we will not fail.
We remember our Cub Scout Promise in everything we do.
Won't you all please join us as we pledge ourselves anew.

(Leads boys and audience in Cub Scout Promise)

PAGE 4 MAY
WHEELS, WINGS AND RUDDERS



SONGS

WHEN YOU TRAVEL
TUNE: *Clementine*

When you travel, don't unravel
Plan your trip ahead of time.
Those who go around in circles
Never leave and stay behind

SONGS
PINWOOD DERBY CAR
TUNE: *My Bonnie*

My car is hung up on the race
track.
The darn thing won't move up or
down,
If only I'd followed instructions
I'd have the best race car in town.
Chorus:
Bring back, bring back,
Oh bring back my pinewood to me
again
The race, cause next time I will
win.

RACE YOUR CAR
TUNE: *Row, Row, Row your
Boat*

*Race, race, race your car,
Swiftly down the track
If we don't place first this
year
Next year we'll be back!*

THE COMFORTS OF TRAVEL
TUNE: *Clementine*

There are airplanes which we call
jets
Flying high across the sky
Hee and there and everywhere
You can travel, flying high.
But be careful, Cub Scout friends
For hi-jacked your plane could be;

And you'll end up in the wrong
place
From where you had meant to be.

If by bus you choose to travel
You will find all comforts there
There's a restroom where you can
groom
An conditioners for fresh air.
But remember, there's a meal stop
When the busy line you fight;
And sometimes you will be lucky
If there's time to get a bite.

And there's always your own car
Which can dive most anyplace
Seeing sights and resting nights
You can drive at your own pace.
But of course you must remember
All the traffic and heaches
Making you so very tired.
That you may slam on your brakes.

PILE OF TIN

I'm a little pile of tin
I don't know what I might have
been

I've got four wheels and a running
board
I'm not a chevy, I'm a Ford

REPEAT 3 TIMES

Pop, pop
Rattle, rattle
Crash, crash
Beep, beep



PAGE 5 MAY WHEELS, WINGS AND RUDDERS



SONGS - CONTINUED

WHEELS, WINGS AND RUDDERS

TUNE: *Oh Susanna*

Oh I built a plane
With shiny wings,
I love to watch it fly
It soars and sails
Up in the clear blue sky

CHORUS:

I'm a Cub Scout!
I work 'til day is done
With Wheel and wings and rudders
too.
We always have such fun!

Oh I cut out sails
And carved a Keel
And made my little boat
And when I put it
On the pond
With pride I watched it float

CHORUS:

Now I worked with Dad
With wood and paint
We built a pinewood car.
It whizzed right down
The derby Track
And now I am a star!

WHAT TO DO THIS MONTH:

Pinewood Derby Race
Raingutter regatta
Space regatta
Rocket launch
Cub mobile races
Wagon Races

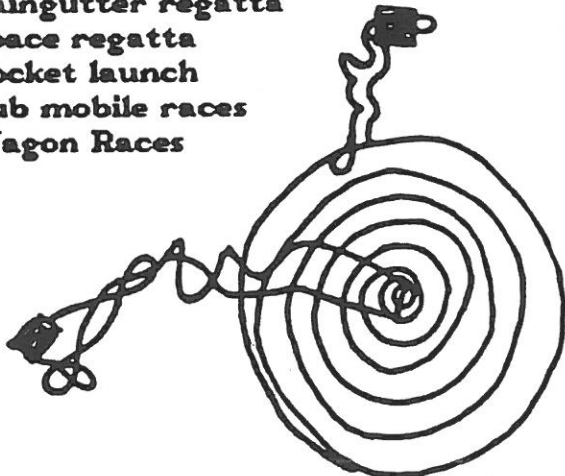

CRAFTS

SPEED SPINNER

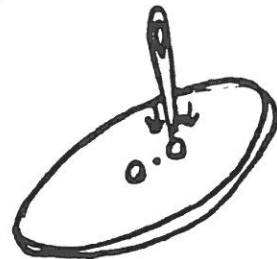

Materials:

1 plastic jar lid
Construction paper
markers
2 pieces heavy string 30" each
pencil

1. Cut 4 strips of paper 1" x12". Overlap ends and glue together creating one long paper strip.
2. Roll long strips around a pencil, glue end closed. Repeat steps 1 & 2 to create a second paper roll bead.
3. Using lid as a pattern cut 2 circles with a design
4. Decorate one side of each circle with a design.
5. Glue one circle to each side of the plastic lid(trim if necessary).
6. Poke 2 holes 1/4" from center of lid.
7. thread on piece of string through first hole and back through second hole. Both ends of string will be on the same side.
8. Thread paper bead on end of string
9. Even up the ends and tie a knot
10. Repeat steps 7 and 9 using the same holes and having string end up on the other side of the lid.
11. Move string around until the knot is under the paper bead and the lid is in the center of the string with bead handles at each end.
12. Holding a bead in each hand flip lid in a circular motion until string is slightly twisted.
13. Pull on beads to tighten string, then relax the string and pull again. This pull and relax rhythm will start your speedy spinner spinning.

**PAGE 6 MAY
WHEELS, WINGS AND RUDDERS**



FLOWER MOBILE

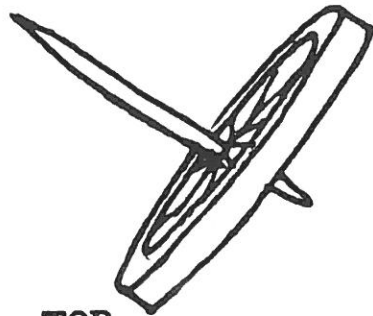

TOP

MATERIALS:

- Several Mayonnaise or Coffee creamer jar lids (they are white)
- 1 - 10" wicker mat
- Green embroidery floss
- Yellow construction paper
- White Construction Paper
- Green Construction Paper
- White Spray paint
- 1 plastic or metal curtain ring

Materials

- Small plastic lid
- Construction paper
- 1 round toothpick

1. Using the lid as a pattern trace around it on white paper
2. Cut out a circle
3. Using markers create your own design on the paper circle and glue to the lid.
4. Carefully poke toothpick through center of the lid about 1/2 way and your top is ready to spin.

1. Using petal pattern C, cut 7 white petals (1/2 lid takes 8) Fold and notch as shown.
2. Using lid as a pattern cut 2 yellow circles.
3. Using leaf pattern B cut several green leaves
4. Glue yellow circles to inside and outside of lid.
5. Using a black marker draw a face on inside of lid as shown
6. Glue petals evenly spaced around the outer edge of the lid just under the rim.
7. Repeat stepd 1-6 for the number of flowers you would like on your mobile.
8. Tie 4 pieces of green floss evenly spaced around the outer edge of the mat
9. Tie all 4 joined pieces around ring keeping mat level so it hangs straight Sig A
10. Glue floss to each lid at the top of the flower so face is straight (allow to dry)
11. Hang the flowers unevenly as shown.
12. Glue the flat side of leaves to the floss as shown.

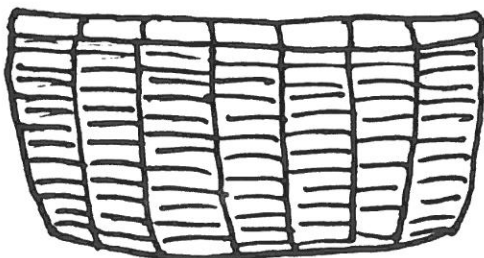

WOVEN BOWL

MATERIALS:

- 1 plastic bowl(Cool Whip)
- Yarn

1. Cut an uneven number of weaving tabs around the entire bowl
2. Start weaving at very bottom of slits in and out til the entire bowl is woven. Glue ends so it won't unravel

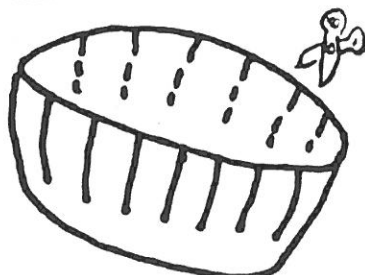

**PAGE 7 MAY
WHEELS, WINGS AND RUDDERS**

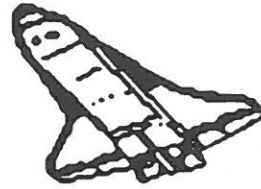

CRAFTS

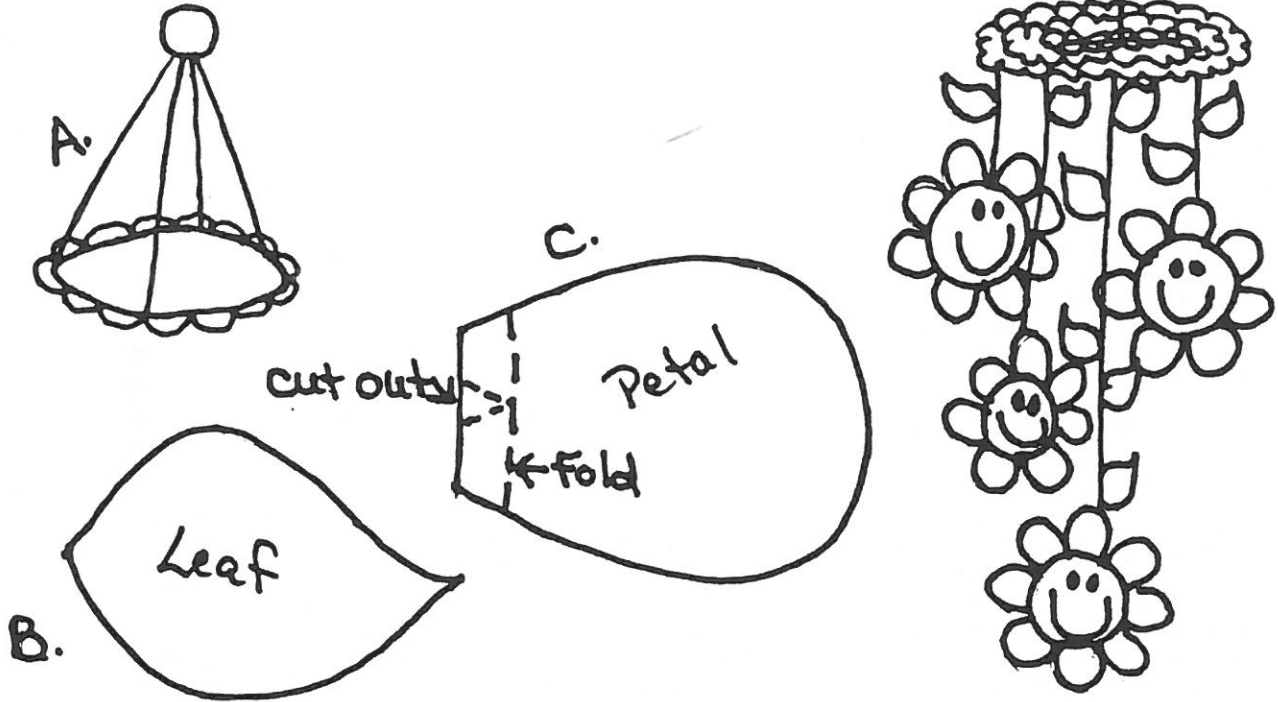

PINWHEEL SPINNER

You can make one of these with a six-inch square of heavy paper or cardboard, a thumbtack or straight pin and a pencil (or stick about that size). Follow these directions:

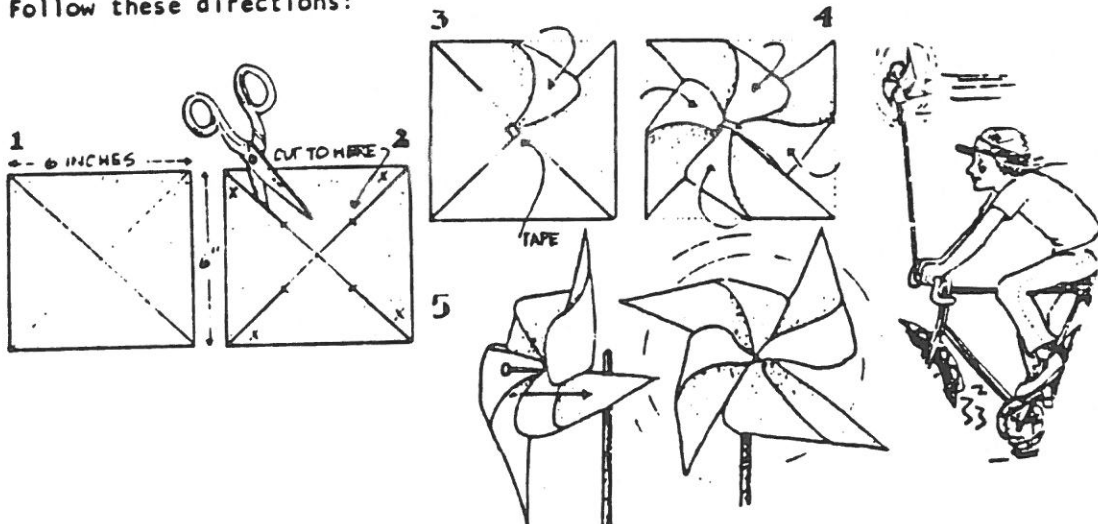

PAGE 8 MAY WHEELS, WINGS AND RUDDERS

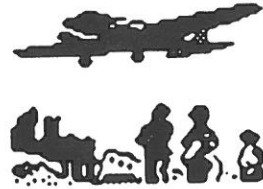

HOW TO BUILD A THINGAMAJIG

DOODADS: Clickety clack,clickety clack
DINGFORD: Whiz, bang, boom
FREEDISTANT: Whoosh, whoosh
HYGORICKY[®] Snap, crackle, pop
SCATUHREEKUS: ALL sounds together

Very few families these days can get along without a thingamajig. While you can purchase them already assembled, in a wide range of sizes, shapes, and colors, they are relatively easy to put together yourself using one of the many kits available. Just follow these directions and you'll have yours built in no time at all.

The Doodads _____ of the thingamajig kit are enclosed in a plastic gizmo and stapled with the yellow assembly Dingford _____ to a Freedistant _____. The assembly Dingford _____ may be placed upon any corrugated doomaflatchy or Freedistant _____ to assemble your Doodads _____. Carefully remove the plastic gizmo of the Doodads _____ from the Freedistant _____ and lay out the Doodads _____ on a clean acka-muhrackus. Learn the name of each Doodad _____ by comparing with the assembly Dingford _____ and assemble the Doodads _____ in the order listed. You will need a dealy with a 3/16" gizflunky for the Hygorickys _____, and a pair of shirilloracks.

Using a witchafiggle, carefully punch 1/8" whatnots through the assembly Dingford _____ and Freedistant _____ where each Hygoricky _____ goes. These whatnots are openings for the hoosis Hygorickys _____ used to frammis the Doodads _____ together. Now frammis the chingus to the Freedistant _____, being careful to place the whatchamacallits catiwompas to the hootnanny and under the Hygorickys _____, as shown on the Dingford _____. If the chingus is reversed, chingadera for schmenahaws, the thingamajig will not function properly.

Tighten two fistareous valves underneath the Freedistant _____ using your delay. The fistareous valves are used to widget the thingamajig hickeys from one Doodad _____ to another. Now glommis a jigger to the demesanti and the doorfunkey by the whatchamacallits. Put a dingus on each Hygoricky _____ and tighten to the Dingford _____. Be sure the Thingus is loose enough so that the thingamabob can rotate easily, but don't have it sloppy loose, or it might become discombooberated and fly off and hit somebody in the doochinkey.

Now you're done and should have a smoothly operating thingamajig when you turn the Scatuhreekus _____.

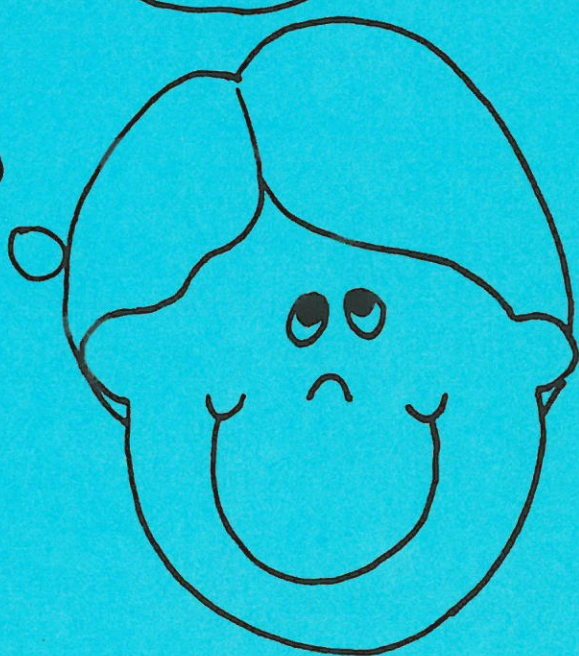

**JUNE
AKELA'S COUNCIL**

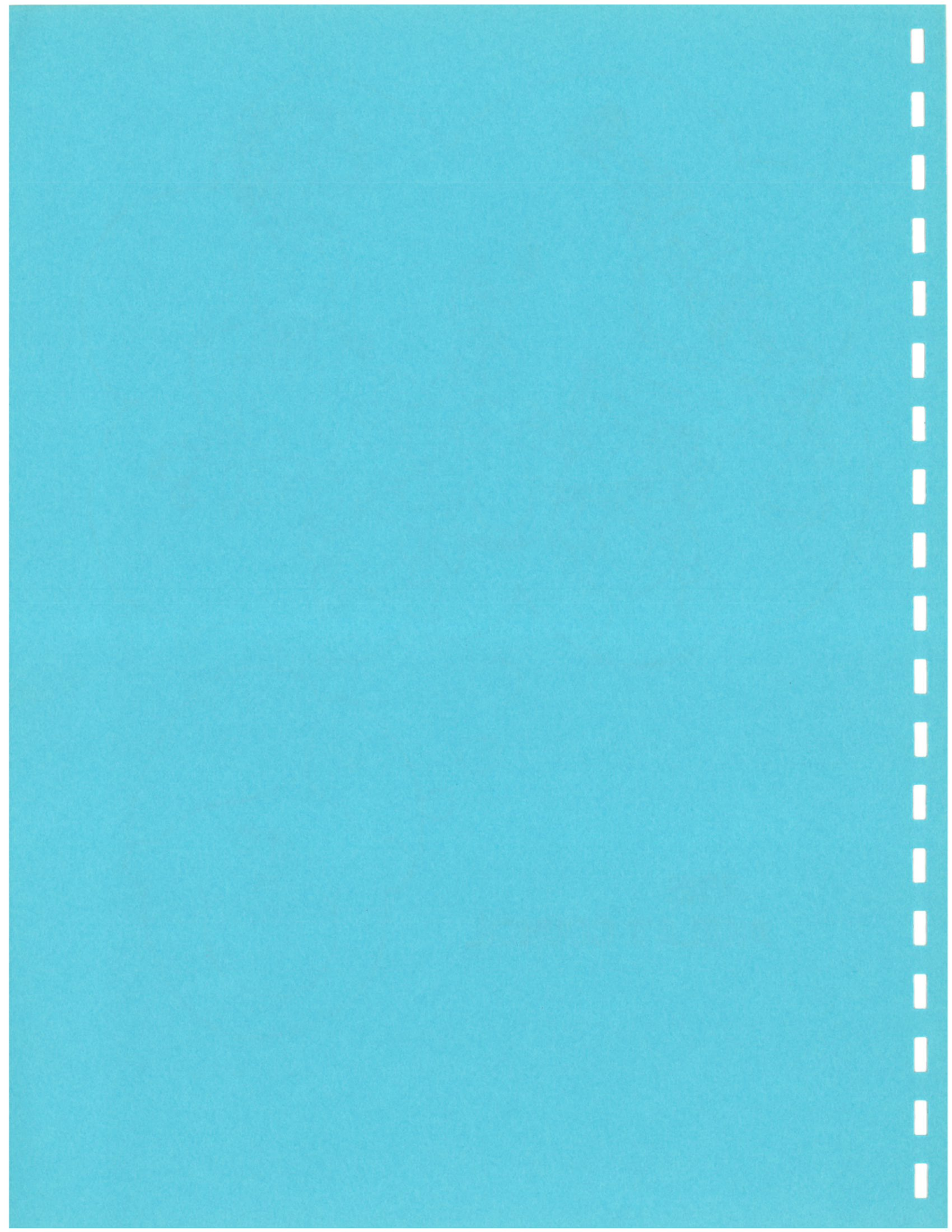

JUNE AKELA'S COUNCIL



OPENING CEREMONY

INDIAN OPENING CEREMONY *San Diego Council*

ARRANGEMENT: One Cub Scout dressed in Indian costume is seated on floor with tom-tom on one side of stage. Other Cub Scouts in uniform (any number) are standing in center of stage with Cubmaster. As Indian beats out messages on the tom-tom, the Cub Scouts take turns "translating" for Cubmaster.

(Indian beats a short message on tom-tom)

1st CUB: Running Deer says that a meeting of Akela's tribe will be held tonight.

(Cubmaster nods in understanding)
(Indian beats out another message)

2nd CUB: He says that many awards will be given at the meeting.

(Cubmaster nods. Indian beats out another message)

3rd CUB: He says that many of the braves have advanced along the trail of the Arrow of Light.

(Cubmaster nods. Indian beats out another message)

4th CUB: He says that there will be singing and games at the meeting.

(Cubmaster nods. Indian beats out another message)

5th CUB: He says that many good leaders will be at the meeting and many families of Akela's tribe.

(Cubmaster nods. Indian beats out another message. All boys shake their heads, shrug their shoulders, to show that they don't understand)

(Indian beats out the same message again. Boys repeat motions of confusion and lack of understanding. Indian beats out message for the third time. Finally Cubmaster says:)

Cubmaster: I've got it! Running Deer says to telephone him if there's anything we want him to bring to the meeting.

ALL CUBS: (disgustedly) Telephone! Good Grief!!

CURTAIN

PUPPET PLAY *Torrey Pines Council*

PUPPETS: Indian Chief
Medicine Man

SETTING: Indian Chief and Medicine Man are sitting by a campfire.

Chief: Oh! Ugh! Oh! Ugh!

Medicine Man: What you 'ugh' about Chief Running Bear?

Chief: Have very bad dream - every night - over and over

Medicine Man: You go to sleep. I make strong medicine and see your dream too!

(Chief pretends to go to sleep. 3 Totem Poles enter doing Indian Dance Step)



CONTINUED PAGE 2

PUPPET PLAY CONTINUED

1st Totem Pole: I'm always low man on the totem pole. Why? Why I always low man?

2nd Totem Pole: You got short feather. That's why. Too Bad!!

3rd Totem Pole: How about me? I'm top man on totem pole!!

1st Totem Pole: I'll change!! I'll change!!

3rd Totem Pole: Oh good! (aside to audience) Big, big bird migration come over here this year!!

(Totem Poles leave)

(Chief wakes up)

Chief: What my dream mean?

Medicine Man: It very clear! Buffalo meat has bad spirit. Must put in refrigerator. Then no more dream!!

ADVANCEMENT CEREMONY

AKELA'S LIFE

ARRANGEMENT: Ceremony board or log with three small candles and one large candle sets on table. Tom-tom beats. Akela enters and stands behind artificial campfire. He gives the Cub Scout sign and the tom-tom stops.

NARRATOR: Akela was the big Chief of the Webelos tribe; tall, stalwart, straight as an arrow, swift as an antelope, brave as a lion. He was fierce to an enemy, but

kind to a brother. Many trophies hung in his tepee. His father was the son of the great yellow sun in the sky. He was called "Arrow of Light". His mother, from whom he learned those wonderful things that mothers know, was called "Kind Eyes". His father helped him make a little bow and arrow and once, when an enemy would have tomahawked his mother, Akela, from his papoose basket shot the enemy in the eye, and saved his mother's life. Later, he began to understand the signs and calls of the Webelos tribe. Then he was taken on little trips into the forest among the great trees and streams. Here, from the Wolf, he learned the language of the ground, the tracks and the ways to food.

(Akela lights large candle representing 'Spirit of Akela', and using that, lights the small candle represent Wolf)

Akela: With this candle, representing the 'Spirit of Akela' I light the trail of the Wolf. From the signs along the Wolf trail, I see that the following braves of our tribe are ready for advancement in the Wolf Clan of Akela's tribe (Calls names of boys receiving Wolf badges and arrow points. They come forward with parents. He presents their awards)

Narrator: Then from the big kindly Bears, Akela learned the secret names of the trees, the calls of birds and the language of the air.

Akela: (Lighting Bear candle) With the 'Spirit of Akela', we light the Bear trail. From the signs along the Bear Trail, I see that the following braves are ready for advancement in the Bear Clan of Akela's tribe. (He calls forward boys who are

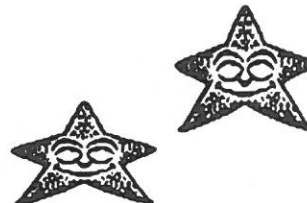

receiving Bear badges and arrow
AKELA'S LIFE STORY - CONT'D

points and presents awards)

Narrator: But before he could become a Scouting "brave" on his own, Akela had to prove to himself by trying out new skills, performing certain tasks and passing tests of accomplishment.

Akela: (Lighting the Webelos candle) With the 'Spirit of Akela' we light the trail to the Webelos. From the signs along the Webelos trail, I see that the following braves have shown their skill in . (He calls names of boys reciving activity badges and indicates which badges they have earned)

Narrator: Then Akela was required to pass the highest test of all. He had to prove himself qualified to wear his father's name "Arrow of Light".

Akela: From the signs further on down the Webelos trail, I see that the following braves have proven themselves worthy to wear the "Arrow of Light", the highest award in Akela's tribe. (He calls names, and as awards are presented, tom-tom begins to beat again at a rapid pace . then drum stops) From the four winds Akela hears that you braves are going well along the trails that will lead you to Scouting. Now will all Cub Scouts stand and repeat the Cub Scout Promise.

ADVANCEMENT CEREMONY

PROPS: "Trophy Skin", badges and arrow points. Pin badges and arrow points on trophy skin in ascending order - Wolf Badges and arrow

points on bottom. Arrow of Light of Light awards on top.

Cubmaster: This month our Cub Scouts have been working hard to advance in rank. Tonight, we will honor those who have achieved a new rank or earned arrow points.

We are very proud of them - and of parents too. Because, you know, a Cub Scout can't advance without the help of his family. Our Webelos Scouts don't pass their badges to their parents, but they need their encouragement. So we're going to ask them to take part in our ceremony, too.

(Cubmaster then calls forward boys who have earned Wolf Rank, with their parents. Each boy takes his Wolf badge from the trophy skin and parent pins it on his uniform while the Cubmaster briefly explains how it was earned by completeing 12 achievements. Follow the same procedure for the Bear badge and for arrow points.)

Webelos Den Leaders then use the same ceremony for the activity badges and Arrows of Light.

Cubmaster: Advancement is just a part of the fun of Cub Scouting. But it's an important part, because through advancement boys learn new skills that will help them when they join a Scout troop and throughtout their whole lives. Let's give a grand howl for our denmates who advanced tonight.

GRADUATION CEREMONY

PERSONNEL: Cubmaster, 5 pack leaders, boys to be graduated

Arrangement: Cubmaster stands behind table facing the audience.



CONTINUED ON PAGE 4
GRADUATION CEREMONY
CONTINUED

Webelos graduates sit in semi-circle before him. Pack leaders participating stand on either side of the Cubmaster.

Equipment: 1 large colored candle representing (Akela's light)
6 other candles, standing beside the larger one.

CUBMASTER: Webelos is the highest rank in Cub Scouting. To become a Webelos a boy must be 10 years of age. Webelos is the name of our Indian tribe. The letter W.B.L.S. are the first letters of the words, "We'll be loyal Scouts". The Arrow of Light in the insignia stands for advancement along the trail from Wolf Cub Scout, all the way to Boy Scout.

Speaker #1: Akela was a great Indian Chief. He had many Indians in his tribe, because he was a peace-loving chief and tried to do what he thought was best for his people. He thought that if he could do something to hold interest in his people they would be even greater and peace loving than before. (Light candle) This candle represents the spirit of Cub Scouting - that a spirit of giving good will and doing your best. The Cub Scout has started the Scouting trail of adventure. He is now a Bobcat.

Speaker #2: I represent in lighting this candle (does so) the Wolf Cub Scout. This is the first award a boy who is eight years of age works for. He must pass 12 achievements. He has now learned to follow the trail of the Wolf tracks through the

great forest of Scouting adventure. **Speaker #3.** (Lights Candle) This candle represents the Bear Cub Scout. This is the first award a boy of 9 years of age works for. He must pass 12 achievements. The Bear trail has been more difficult to follow. The Bear Cub Scout is in trouble every once and a while. He may put his nose in a bee hive, but he didn't do it twice.

Speaker #4: I light the candle which represents the spirit of Scouting. Remember the spirit of Cub Scouting and Scouting are one and the same. The Spirit of the entire Scouting achievement is service, high ideals and fellowship.

Speaker #5: I light the candle representing the Webelos rank. Webelos means "We'll Be Loyal" - loyal to our country, our home and our God.

Cubmaster: Now, I will present you with the Arrow of Light badge. This is the only Cub Scout badge which can be worn on your Scout uniform. It is an honor for me to make this presentation. And now I would like to introduce Scoutmaster _____ who will continue to help you along the Scouting trail.

(Exchange of neckerchiefs can take place at this point, and the parents can be called forward to meet the Scoutmaster.)

CUBMASTER INDUCTION

Equipment: Indian headdress for Old Chief Akela, artificial campfire, Indian blanket

Setting: Committee Chairman and new Cubmaster stand beside the campfire. SEE PAGE 5 CONT'D -



CUBAMSTER INDUCTION - CONT'D

Former Cubmaster as Old Chief Akela is out of sight.

Chairman: We are expecting a visit from Old Chief Akela of the tribe of Webelos.

(A knock is heard and Old Chief Akela enters)

Old Akela: I am here to help you install a new Chief. Are the elders of the tribe assembled?

Chairman: They are here, Akela

Old Akela: Have they selected a new Chief?

Chairman: They have and he is here. (The new Cubmaster is brought before the old chief).

Old Akela: You have been chosen to be the new chief of the tribe of the Webelos. Will you be loyal to the trust that has been placed in you by our Committee, Cub Scouts, and parents?

New Cubmaster: I will be loyal

(Old Chief puts his blanket on the shoulders of the new Cubmaster and a warbonnet on his head).

Old Akela: I declare you to be Chief Akela, of the tribe of the Webelos of Pack _____ in the Old Baldy Council of the Boys Scouts of America. Do the young braves know the Law of the Pack?

New Cubmaster: They do

Old Akela: The let them give the Law

CUBS:(Repeat the Law of the Pack)

CLOSING CEREMONY

Arrangement: To be read by Cubmaster or Den Chief in full Indian costume. (It will be more impressive if the room is darkened and lighted only by an artificial campfire. Cubmaster can have his arms fold in front of him, chest height, and card concealed that he can read)

**THE TWENTY THIRD PSALM
(AMERICAN INDIAN VERSION)**

The Great Father above is a shepherd chief.

I am His and with Him I want not.

He throws out to me a rope and the name of the rope is Love.

He draws me where the grass is green and the water is not dangerous, and I eat and lie down satisfied.

Sometimes my heart is very weak and falls down, but He lifts it up again and draws me to a good road.

His name is Wonderful

Sometime - it may be longer - He will draw me into a place between the mountains. It is dark there, but I will not draw back.

I will be afraid not, for it is there between these mountains that the Shepherd chief will meet me and the hunger I have felt in my heart through this life shall be satisfied.

Sometimes He makes the Love rope into a whip - but afterwards he gives me a staff to lean upon.

He spreads a table before me with all kinds of food.



**THE TWENTY THIRD PSALM
AMERICAN INDIAN VERSION
CONTINUED**

He puts His hand upon my head
and all the tires is gone.

My cup He fills until it runs over.

What I tell you is true. I lie not.

These roads that are ahead will
stay with me through life and
afterwards I will go to live in the
big teepee of the Sheperd Chief
Forever

**RANK ADVANCEMENT
USING COUNCIL FIRE AND AKELA**

Akela: Tonight, you have come
together before the Council Fire, in
friendship, as I Akela, The Great
Spirit of Scouting, want you to. We
are here to recognize those fellow
braves who have worked har these
past months, and have earned their
rank.

Along the trail of Cub
Scouting there are many chances to
explore ourselves and the world
around us. As you travel this road,
you become stronger in mind and
character, and you make Akela
proud.

Cubmaster: We, too, are proud of
our Scouts tonight, and as we
recognize these Scouts, we also
recognize their parents and leaders.
For without their help, we would
not be gathered here tonight, and
these awards would not be possible.

Akela: As the Council fire shines
tonight, let the spirit of Cub
Scouting shine within you. Take
that Spirit with you always, and in
it make the world a better place

for us all.

Cubmaster: Will tonight's award
receipts please step forward as
your name is called and recieve
your recognition.

CRAFTS

A. Bobbie Hoffman

3 peices of
leather lacing
about 8 to 10 in
long

Six Beads

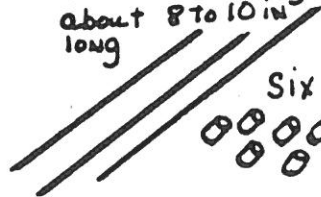

Slide

B. Knot
Braid lacing
together in middle
about 2-3 in.
Tie a knot at
one end to hold
teather while
braiding

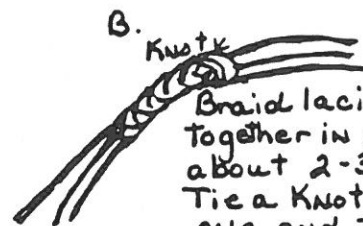

C

glue
back to
hold.
Braid all six
ends together
about 1 in
Put Bead on
ends and
glue to keep
them on
glue with
Hot glue

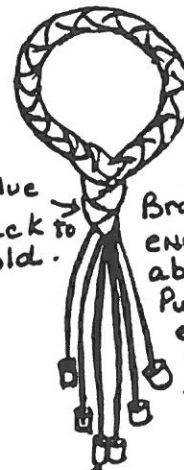



CRAFTS

Tom Tom Drum

A

coffee 1lb
Brown paper bag.
Rubber Band
Large Brown or Black Balloon
Crayons

B.

cut Bag to fit can
Decorate and glue on
CAN.

C. Cut Balloon just above stem

D. Balloon Rubber Band
Put over top of CAN Pull Rubber band around Balloon to hold on CAN

Breech Cloth

A

Large Brown paper Bag.
String
staples
Crayons

B.

cut Bag into two squares (10 to 12 in) and crumple fold top down about 1 in and staple edge. cut ends

C. Decorate squares and pull string through stapled edge and tie around Boy.

Bobbie Hoffman



CRAFTS

PAPER-PLATE WARRIOR SHIELD

Here's what you need:

- 1 large paper plate for each shield
- colored construction paper
- paper paste
- tape or stapler
- 1 sheet of tracing paper for each
- pencil
- scissors

Here's the how:

1. Cut out design shapes from colored construction paper like the ones you see in the illustration.
2. Paste these shapes to the underside or bottom of a paper plate.
3. Make the handle for the shield from a paper strip cut a little longer than the size of the plate. Tape or staple it to the other side of the plate.
4. Trace the feather from the book onto a sheet of tracing paper.
5. Cut out the feather from the tracing paper.
6. Use the feather cutout to trace three feathers onto different colored construction paper.
7. Cut out these feathers and past to the bottom front of the shield.
8. Play with your shield by holding the handle on your arm or hang the shield on your wall as a decoration.

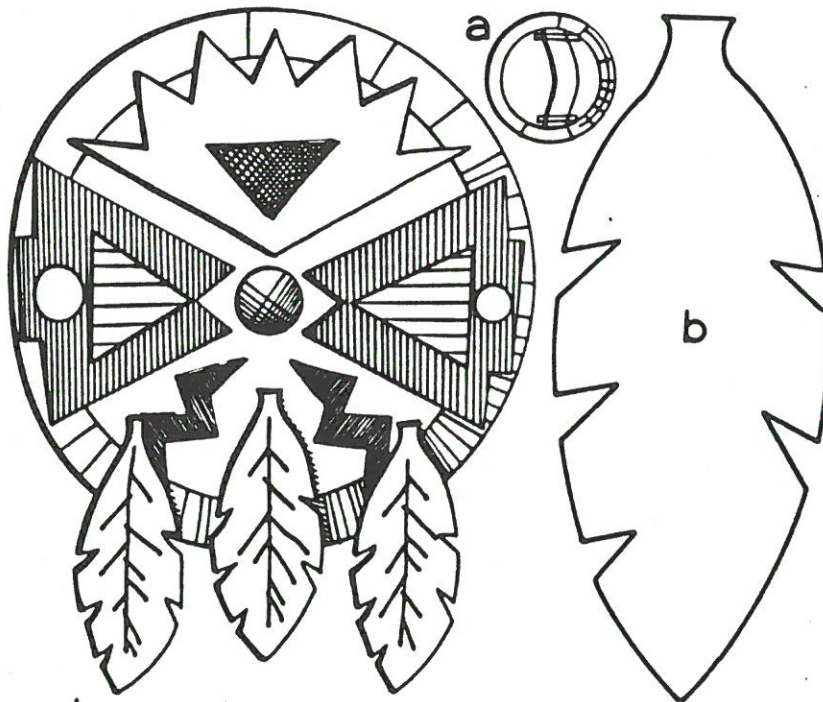

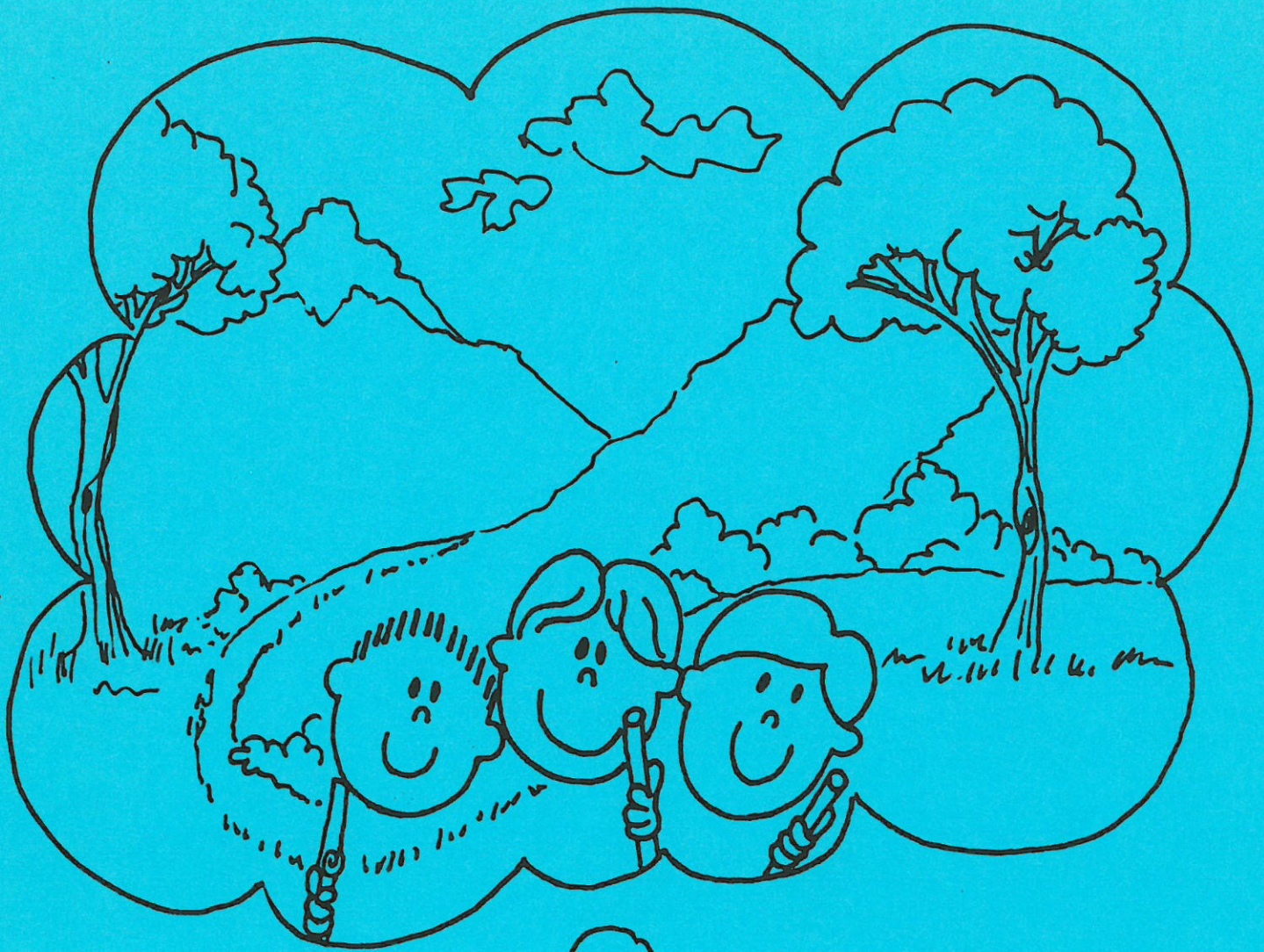

**JULY
TRAILS, TREKS
AND TRIPS**

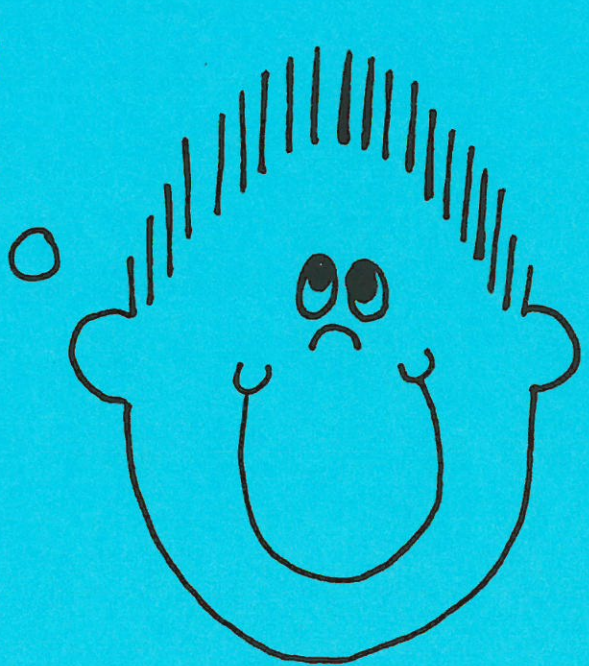

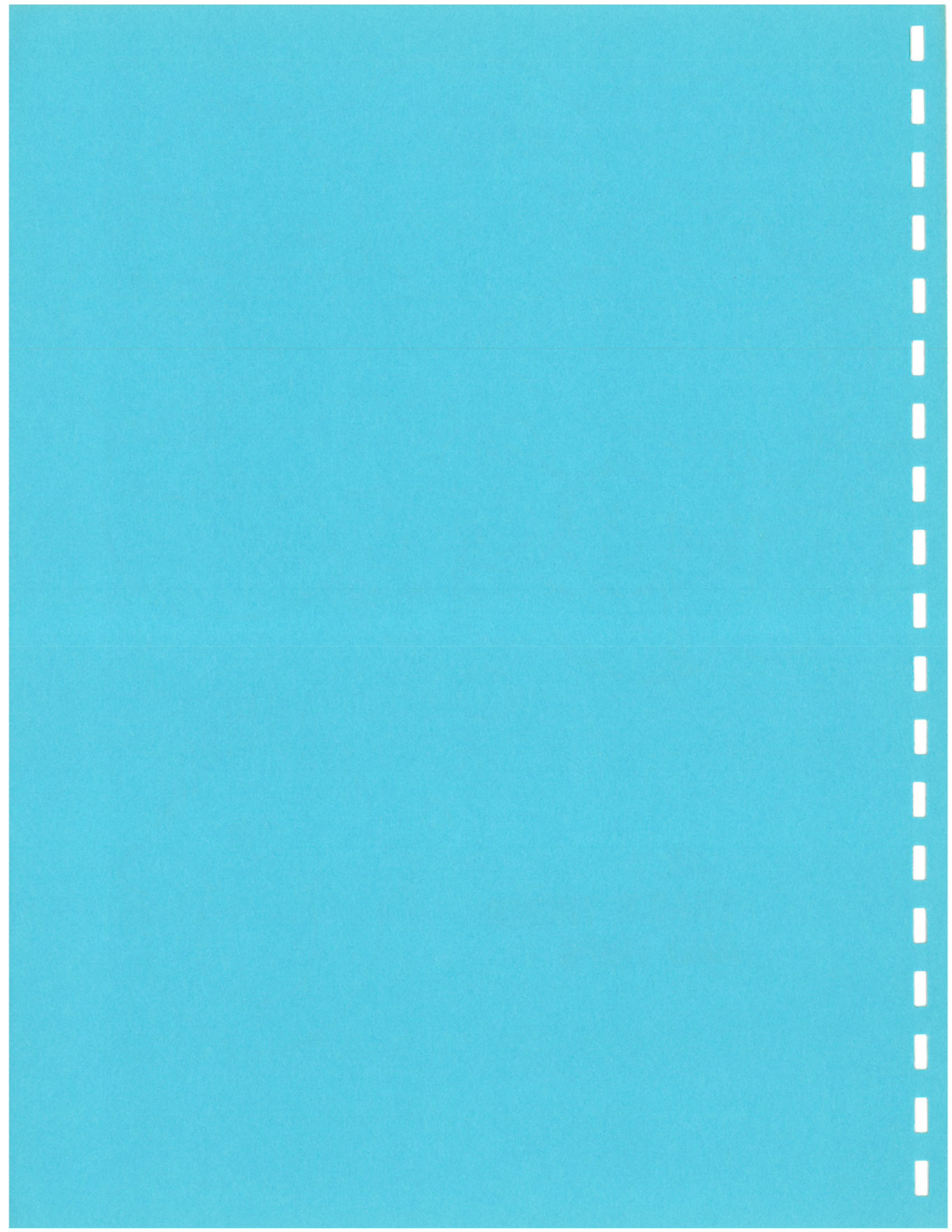

JULY TRAILS, TREKS & TRIPS



OPENING CERMONY

FLAG INTRODUCTIONS 'I PLEDGE ALLEGIANCE'

According to the Charter and Bylaws of the Boy Scouts of America, the goals of the Scouting program are character development, citizenship training and personal fitness. Proper citizenship can't be taught without emphasizing proper respect for the U. S. Flag. When we salute the flag, we should do it with sincerity and appreciation.

Below are listed some different and meaningful introductions to make the flag salute more effective:

Because we are thankful and appreciative of such leaders as Abraham Lincoln, let us salute the flag and at the same time remember all of the great Presidents of our land.

As we salute the flag today, let's remember George Washington, the Father of our country, and the heritage of America.

The 31 words of the Pledge of Allegiance are among the best-known words in America. Let us repeat them now with meaning as we salute the flag.

Our state is represented by one of the 50 stars on the U.S. Flag. Let us now pledge allegiance to our flag as individuals and together for our state.

The flag of the United States of America is the emblem of a free nation - a leader in the free world.

Let us now salute our flag.

Our flag is bright with cheer, brilliant with courage and firm with faith. Let us add to this a sincere salute today.

Our flag stands for all that we hope to be and have the courage to try for. Please join in the Pledge of Allegiance to our flag.

We the people. That's what our flag stands for. Let us salute the U.S. Flag.

To secure the blessings of liberty to ourselves and our posterity is a challenge to all of us. Let us salute our flag.

In the folds of the flag are enshrined every ideal, hope and opportunity made possible because someone has lived. Let us salute the flag.

PATRIOTIC OPENING

THE TALKING PACK FLAG

Personnel: An adult off stage or out of sight behind flag.
A boy about 8 years old dressed in civilian clothes

Equipment: The Pack flag
Flag stand
Tin Can
Spotlight to light flag in darkened hall

Setting: The hall lights are lowered, spotlight is turned on Pack flag and boy with a dejected look strolls across stage kicking tin can. CONT'D

**PAGE 2 JULY
TRAILS, TREKS AND TRIPS**



**THE TALKING PACK FLAG
CONTINUED**

Flag: Hello
BOY: Hi! (then looking around) Who said that?
Flag: I did
Boy: (walking over to flag) A talking flag?
Flag: What's wrong with that?
Boy: Nothing, I guess. What kind of flag are you?
Flag: I'm a Cub Scout Pack Flag. You sure do look sad.
Boy: I am.
Flag: Why?
Boy: Nothing to do.
Flag: I have a program of citizenship training, character building and physical fitness not to mention games, crafts, interesting trips and a lot of other things to do, but I'm pretty sad, too.
Boy: Gee! With all that to do why are you so sad?
Flag: Well, I have so many boys coming to join me this fall that I don't think I'm going to be able to take care of them all.
Boy: Why not?
Flag: Why? Because I need Den Leaders and committeemen.
Boy: What for?
Flag: I need Den leaders to help me with my games and crafts. I need committeemen to help me with pack finances, advancement, publicity, outings, training, membership, to get craft materials for den and pack meetings and so many other things.
Boy: Can I help?
Flag: No. I'm afraid not. My program is for you. It's moms and daads that I need.
Boy: I'll ask my dad and mom to

help you.

Flag: If they will, we can work together and have a better program than ever.

Boy: See you later.

OPENING

PROPS: 6 Cubs

one cup red paper bits
one cup blue paper bits
one cup white paper bits
one cup stars or glitter
large pot
flag and a spotlight

Cubs in a semi-circle around pot (flag in hidden inside)

Cub 1: We are going to fix for you a treat that is really grand. And make for you a recipe - the greatest in the land.

Cub 2: First we'll put in a heaping cup of red for courage true. (toss cup of red paper bits into pot)

Cub 3: The well add for loyalty, a dash of heavenly blue.(adds blue paper bits)

Cub 4: For purity, we will now sift in a layer of snowy white. (adds white paper bits)

Cub 5: We'll sprinkle in a pinch of stars to make it come out right.(adds stars or glitter)

Cub 6: We will stir , then you will see that what we have made is -(stir lightly with large spoon or stick)

All in unison: Old Glory(reach in and pull out flag)

CEREMONY CONT'D

PAGE 3 JULY TRAILS, TREKS AND TRIPS



CONCENTRATION HIKE

Cub 1: Our flag is the most beautiful flag in the world. Let's us always be loyal to it.

Cub 2: To show our allegiance true, we will say the Pledge with you

ADVANCEMENT CEREMONY

Cubmaster: We have several Cub Scouts to honor today for the hard work they have done since our last meeting. With the paper plates, we have the Bobcats. (Call boys and parents forward. Pull Bobcat pin/badges attached to a paper plate from a picnic basket. Present awards and give congratulations.)

Present other badges in same manner: Wolf - napkins; Bear - paper cups; Webelos badge and activity badges - plastic spoons, etc.)

You have seen all of the things that make a picnic meal family fun - except the food. These young men and their parents represent the thing that makes the Pack grow and thrive. They are as important to a Pack as food is to a picnic. Let's wish them well as they continue on their trail to Boy Scouting.

IDEA: If you are out on the trail and you do not have a American flag remember there is a U.S. flag on the moon, planted there by a former Boy Scout. It is appropriate to stand and salute this flag even though it can only be seen through the imagination.

Take a scenic area that includes a number of different kinds of objects, nature settings, and a variety of trees or animals. This might be a park area, or a zoo or even a botanical garden. Tell each Cub to concentrate on remembering everything he sees. Then, when the hike is over, give each Cub a pencil and paper and see who can list the most objects, animals, birds, trees, plants, streams, bridges, rocks, etc. seen along the way. The highest score wins. This maybe done as a team game.

HIKING: Cubs love the out doors. Take some plaster of paris with you and make casting of animal prints. Remind the boys not to damage the fauna. Also, be careful what they touch. Some plants leave rashes. Do a plant identity game on the trail.

SONGS

A WORM'S EYE VIEW

TUNE: Home on the Range

Oh come see my home,
Where I live all alone,
Munching onlon and splnach all day,
Now you may think a worm
Doesn't deserve his turn,
But without me the gardener
would play

Chorus:
Home, home in the squash,
Where I live and I sleep and I eat
The gardener may try
But I'll hide safely inside a beet.



SONGS

CHICKA-BOOM

(Repeat after me)

I say a boom chicka-boom
I say a boom chicka-boom
I say a boom chicka rocka chicka,
rocka chicka boom

Huh, huh
Alright
One more time
*Only teeny weeny

*Like Dracula
*Only Sexy
*Rock out

I LOVE AMERICA

*TUNE: Battle Hymn of the
Republic*

I love this great America,
The land that God has blessed,
Where the hope that stirs the
hearts of men will never be
suppressed
Through the flame of faith came
forth a nation choice above the
rest,
This great America!

Chorus

Glory to the land of freedom
Glory to the land of freedom
Glory to the land of freedom
I love America

I love this great America
The land of liberty
For I know the price of freedom
countless others paid for me.
Do we hear their call to carry on
and serve as valiantly?
This great America!

Chorus

May all men be united
By the bonds of brotherhood,

May we learn to love each other,
for in every man is good.
Let us live in peace upon the land
where men of valor stood.
This great America!

Chorus

I love God's great America,
All equal in His sight.
May we be as one in spirit as we
reach up for the right.
And may we have hummility to
match our power and might.
This Great America!

ELEPHANT SONG

One Elephant went to play on a
Spider's Webb one Day.
He had such enormous fun that he
called for another Elephant to come.

Two Elephants went ...
Three Elephants
Four
Five
Six

LITTERBUGS BEWARE

TUNE: Auld Lang Syne

We are the folks who hunt the bugs
That litter up our streets
With papers, bottles, old tin cans
And wrappers off their sweets

We want to keep our playground
clean
Without a lot of fuss
Let's start today to do our share
No litterbugs for us!

No litterbugs, no litterbugs,
No litterbugs for us.
Let's start today to do our share
No litterbugs for us!

**PAGE 5 JULY
TRAILS, TREKS AND TRIPS**

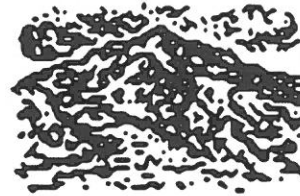

Journey to Morrow

Equipment: Suitcases for Cubs to carry. Stationmaster's window.
Personnel: 6 Cub Scouts (some parts can be combined for fewer Scouts)
(Group of 5 Cubs walks on stage carrying baggage, packages, etc.
Stationmaster is already in his window.)

Cub 1: I started on a journey about a year ago
To a little town named Morrow in the state of O-hi-o
I've never been much of a traveler, and I really didn't know
That Morrow was the hardest place I'd ever try to go!

Cub 2: So I went down to the station for my ticket and applied
For tips regarding Morrow not expecting to be guiled
Said I my friend I'd like to go to Morrow and return
No later than tomorrow for I have no time to burn

Stationmaster:

Now let me see if I have heard you right
You'd like to go to Morrow and return tomorrow night
You should have gone to Morrow yesterday and back today
For the train that goes to Morrow is a mile upon it's way
If you had gone to Morrow yesterday, now don't you see
You could have gone to Morrow and returned today at three
For the train today to Morrow, if the schedule is right
Today it goes to Morrow and returns tomorrow night

Cub 3: My friend, it seems to me you're talking through your hat
There is a town named Morrow on the line? Now tell me that

Stationmaster:

Yes there is, but take from me a quiet little tip
To go from here to Morrow is a 14 hour trip
The train today to Morrow leaves today at 8:35
At half-past 10 tomorrow is the time it should arrive

Cub 4: I'd like to go to Morrow, but can I go today?
And get to Morrow by tonight, if there is no delay?

Stationmaster:

Well, oh, well. And I've got no more to say
Can you get anywhere tomorrow and get back again today?

Cub 5: Well, I guess you know it all, but kindly let me say
How can I get to Morrow if I leave this town today?

Stationmaster:

You cannot get to Morrow any more today
'Cause the train that goes to Morrow is a mile upon it's way

Cub 1: I was so disappointed

Cub 2: I was mad enough to swear

Cub 3: The train had gone to Morrow

Cub 4: And had left me standing there

Cub 5: The man was right in telling me that I was a howling jay!

All Cubs: I could not go to Morrow, so I guess in town I'll stay!



CRAFTS

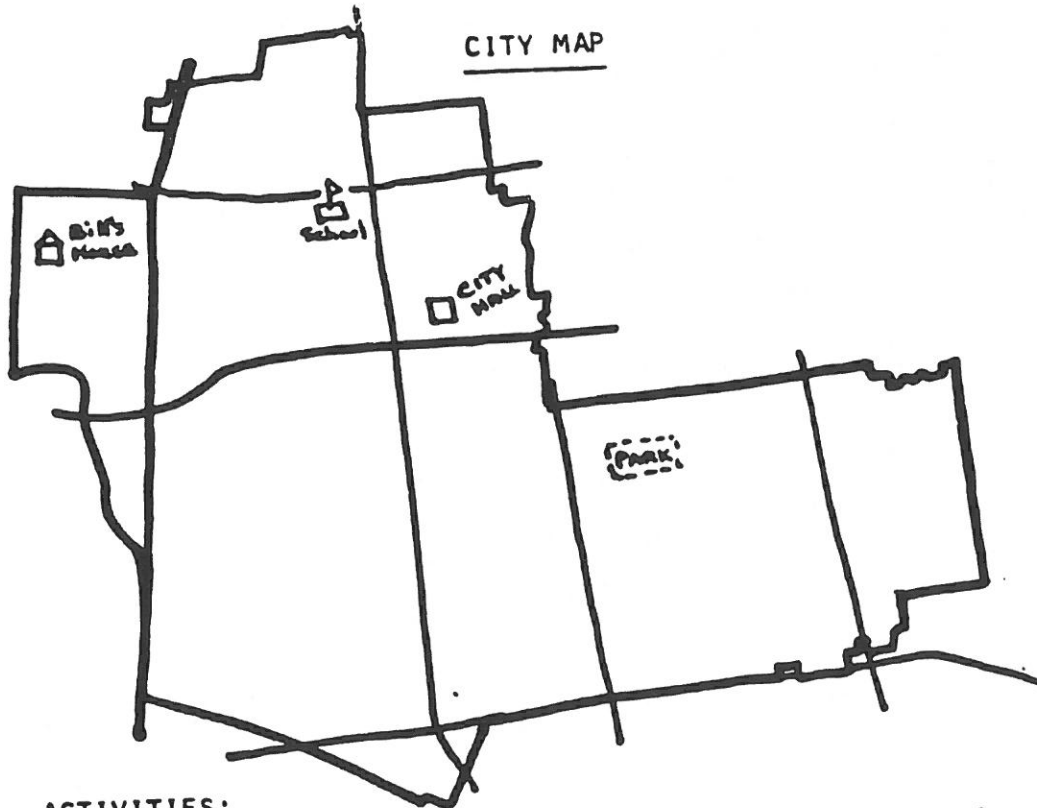

ACTIVITIES:

1. Find out the boundaries of your neighborhood. Make a large map showing the boundaries.
2. Mark on the map where each member of your den lives.
3. Mark points of interest in your city. e.g. library, city hall, school, etc.
4. Mark important streets.

GETTING TO KNOW YOUR CITY

IDEAS:

1. Learn about the history of your city. Find out how it got its name, famous residents, different groups who once lived there, historical landmarks, & interesting stories. The public library is a good place to start.
2. Visit some of the famous residents, leading business people, long-time residents, and other interesting people. Find out what they think of your city and how it can be improved.
3. Plan a project to help improve your city. e.g. plant a tree, paint a wall or fence, clean-up project.
4. Find out how to get around your neighborhood by public transportation. Take a ride on a bus.
5. Plan a walking tour in your city. Draw a map. Take the tour.
6. Plan a bicycle ride in your city.

PAGE 7 JULY TRAILS, TREKS AND TRIPS



CRAFTS

COFFEE-CAN TOTEM POLE

What you need

coffee cans with lids
colored construction paper
tape
scissors
paper paste

Instructions

1. Wrap a piece of colored construction paper around each can.
2. Tape the paper together around the cans.
3. Trim away any extra paper that may go above and below the cans.
4. Cut out three feather shapes from the colored construction paper. Paste them to the top of one of the cans.
5. Paste a long strip of paper to the back of that can. Glue feather shapes to this strip.
6. Cut out funny paper eyes, noses, mouths, and crazy war-paint shapes.
7. Using these, paste a face to each can.
8. Make the totem pole by putting one can on top of the other.
9. The more cans you make, the taller your totem pole will be.

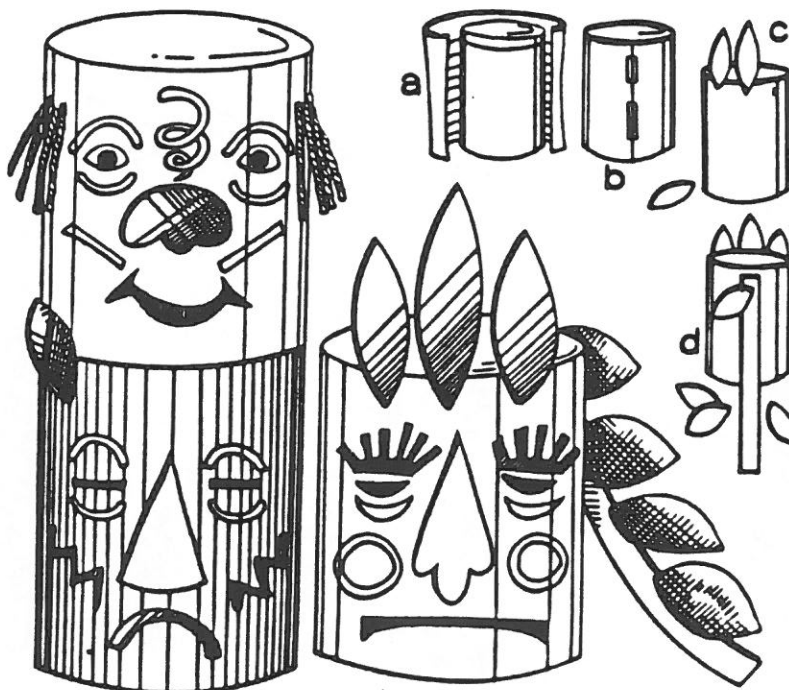

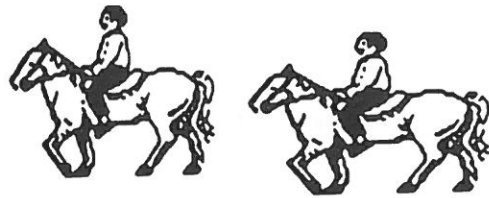

CRAFTS

DAD

STAR SPANGLED STREAMER

Materials:

- 4 wooden ice cream sticks
- Blue paint
- glue
- Red and white construction paper

1. Paint ice cream sticks blue. Let dry
2. Glue sticks together, one on top of the other, to form an eight pointed star.
3. Cut small stars from white construction paper and glue them to the sticks as pictured.
4. Cut 3 strips of red paper and 2 white ones
5. Alternating the colors, glue the strips to the ends of the sticks so that the strips hang straight down.
6. Glue a piece of thread to the uppermost point of the star.

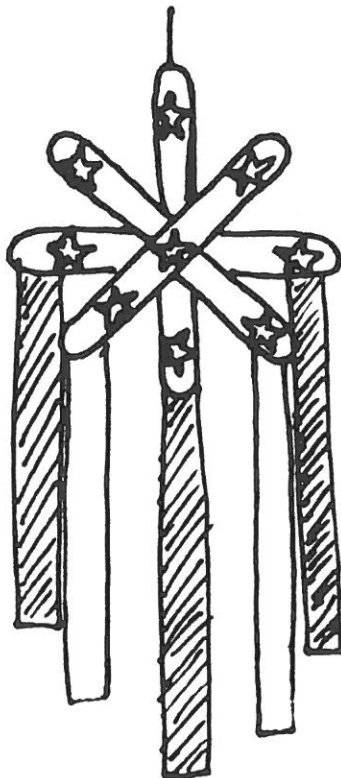

Materials:

- Assorted colors of construction paper. You will need different color for each letter of your name. Cut strips 1" x 24". (If necessary glue 2 strips together to get a 24" piece.)
- Pencil and glue

1. Cut enough strips to make letters at least 4" high
2. To wrap paper strip moisten one end and place that end over your pencil, turn and wrap the entire piece tightly around the pencil (Fig A)
3. Glue end flap closed and carefully slip completed roll off the pencil.
4. Glue each side of a roll where it touches another roll until you have glued and shaped each letter of your name.
5. To form name glue letter together anywhere they touch. Allow to dry before standing up.

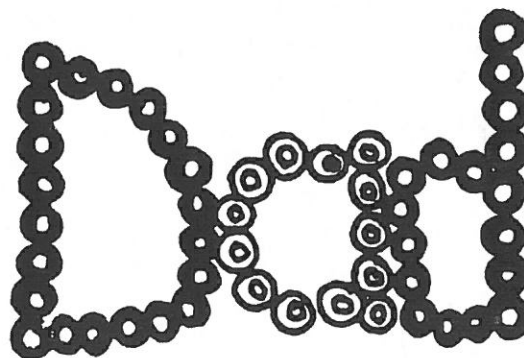
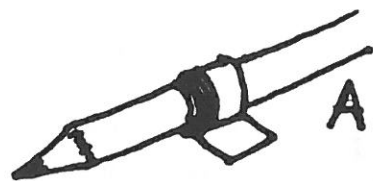

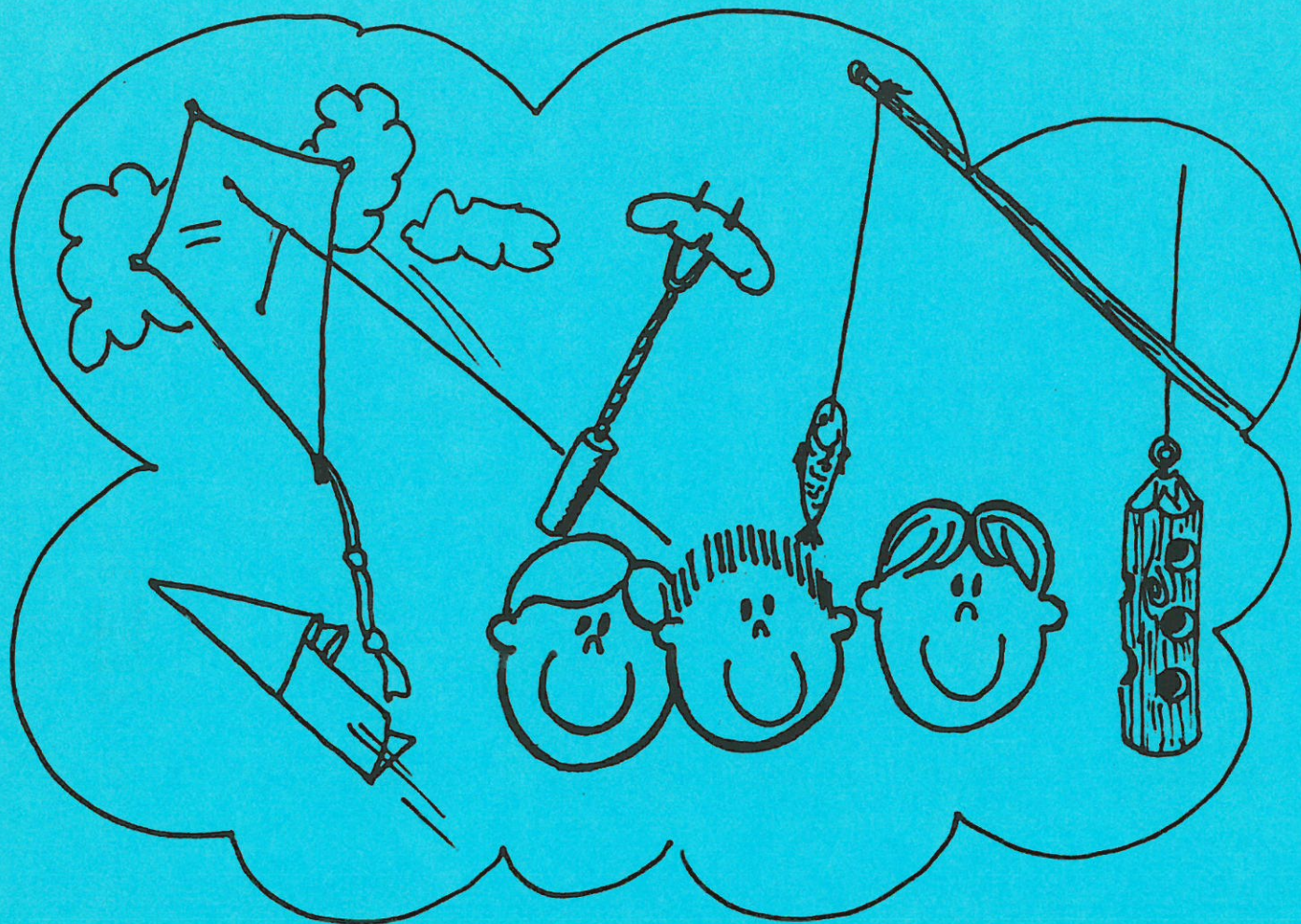

**AUGUST
OUTDOOR FESTIVAL**



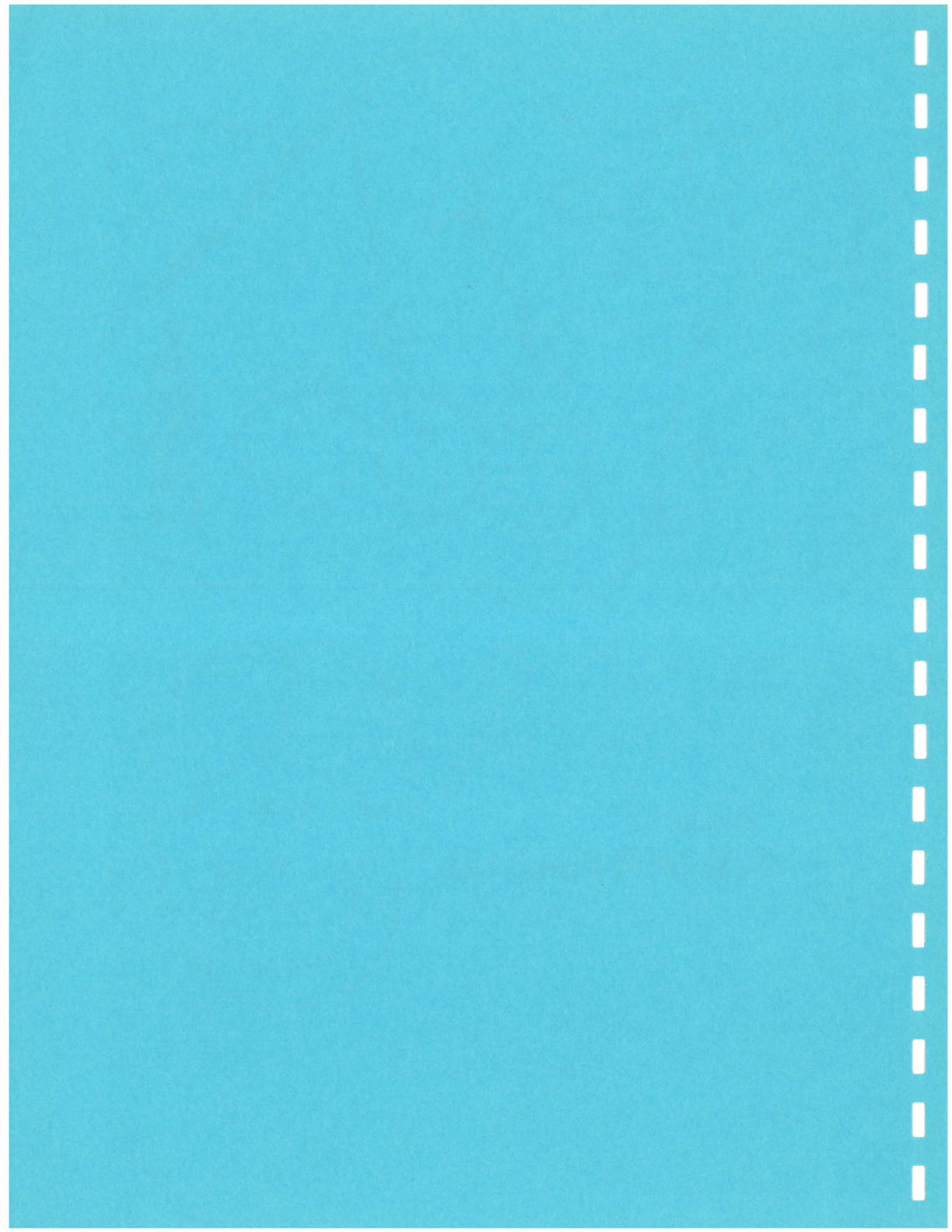

AUGUST OUTDOOR FESTIVAL

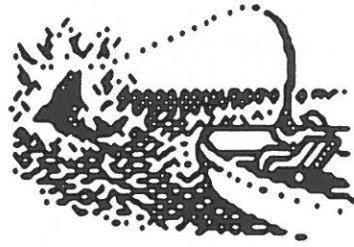

OPENING CEREMONY

Cubmaster: Off the shore of Long Beach are several man-made islands. They serve the purpose of tapping one of our great natural resources - oil that lies beneath the water.

Oil is the lubricant of our nation, it keeps friction to a minimum. Oil provides the heat for many homes. Refined oil moves our nation in the form of gasoline for cars, trucks, trains and planes. Oil gets us where we want to go.

Here in Los Angeles County there are several special islands to tap a different natural resource - BSA in the form of Packs and Troops.

Our greatest natural resource is a boy. He provides warmth for many homes and lives he touches. In his refined form he'll move our nation and help us get where we want to go. The BSA Island is a method of tapping the character and citizenship within our greatest natural resource.

KING NEPTUNE'S COURT

Props: Cubmaster is King Neptune (costumed), wig and beard made of gray yarn or a mop head. Crown made of cardboard or construction paper, sheet or blanket draped over on shoulder, pulled together at sides and held with rope tied at waist, trident with three prongs, sandals or barefoot.

KING NEPTUNE'S COURT CONTD

Cubmaster points to boy advancing. Calls him forward. Boy kneels in front of King Neptune. Neptune touches boy on shoulder with trident and says:

"You have crossed the Cub Scout Equator of Advancement and landed on the Island of ___ (Wolf, Bear, etc) ___. You will now set your compass for the next island on the Cub Scout Map. I, King Neptune, magistrate of the undersea empire hereby dub you Sea ___ (rank) ___.

SKIT

PURE WATER

Visitor: So you say the water around Old Baldy Council is not so good?

Scout 1: Yep. It's mighty poor.

Visitor: Well, what do you do about it?

Scout 3: The State said it wasn't safe. So we boil it.

Visitor: Is that all?

Scout 3: Then we filter it.

Visitor: Yes?

Scout 4: Then we add certain chemicals like halazone to it.

Visitor: Yes?

Scout 5: Then we take a real close look at it and take a whiff. (Scout 5 holds a glass up to his nose)

PAGE 2 AUGUST OUTDOOR FESTIVAL



leave a border so it will stick.

and
PURE WATER - CONT'D

sniffs loudly.)

Visitor: Yes?

All Scouts: Then we drink
something else!



CRAFTS

NATURES DECALS

Materials:

Small flowers or colored leaves
Transparent adhesive plastic
Scissors

1. Dry flowers or leaves thoroughly and press as flat as possible.
2. Peel a strip of backing from the roll of clear plastic and place it on a flat surface. Do not cut off the backing, simply peel it free of a strip of the sticky plastic.
3. With the adhesive side facing you, place flower face down or leaf face down on the sticky surface. Leave at least 1/2" between the items and about 3/8" from the edge of the plastic. This allows a margin for cutting.
4. When the entire strip is filled, replace the backing and smooth it firmly into place again.
5. Cut the entire strip from the roll.
6. Remove each decal as you need it by cutting through both plastic and backing. Be sure to

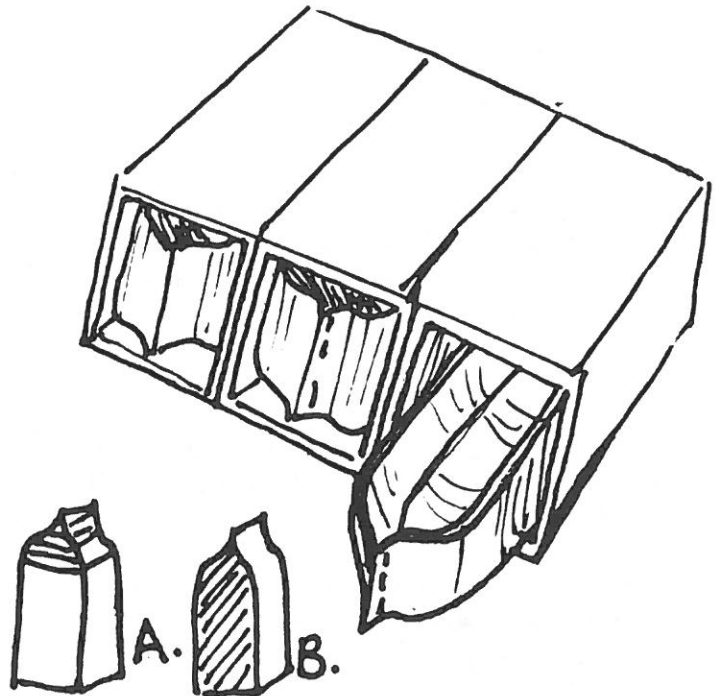

WORKSHOP ORGANIZER

Materials:

3 quart-sized milk cartons
3 half gallon milk cartons
stapler, scissors
poster paint, glue
brush
kitchen cleanser

1. Staple the open end of 3 quart-sized milk cartons closed with a stapler.
2. Cut away the top of 3 half gallon cartons; see shaded area in figure A.
3. Cut away one side of each quart-sized carton, to the peak; see shaded area in fig. B
4. Paint the outer sides of all cartons with poster paint that has a little kitchen cleanser added. The cleanser will make the paint stick.
5. Glue the sides of the 3 half-gallon cartons together.
6. Slip the quart-sized cartons into the half-gallon cartons. The

PAGE 3 AUGUST OUTDOOR FESTIVAL



peaked side will serve as a handle.

CRAFTS - CONTINUED

OAK-LEAF SEED PAINTING

Supplies

dried watermelon, cataloupe, and honeydew melon seeds
seeds from spice rack, like poppy, fennel caraway or mustard
seeds
liquid white or brown glue
small cup
typewriter paper
paper paste
pencil
scissors
tracing paper
watercolor brush

Directions

1. Trace the oak design from the book onto a sheet of typewriter paper.
2. Paste the paper with its tracing onto a sheet of cardboard with paper paste.
3. Pour liquid white or brown glue into a small paper cup.
4. Use a water color brush to brush glue into one area of the design, for example, an oak leaf.
5. Arrange the large seeds along the outline of the glued area first, then work them inward until the whole space is filled.
6. To work with the smaller seeds, merely sprinkle seeds onto the glued area and blow away any that do not stick. Proceed to glue and fill all areas in the way that you wish.

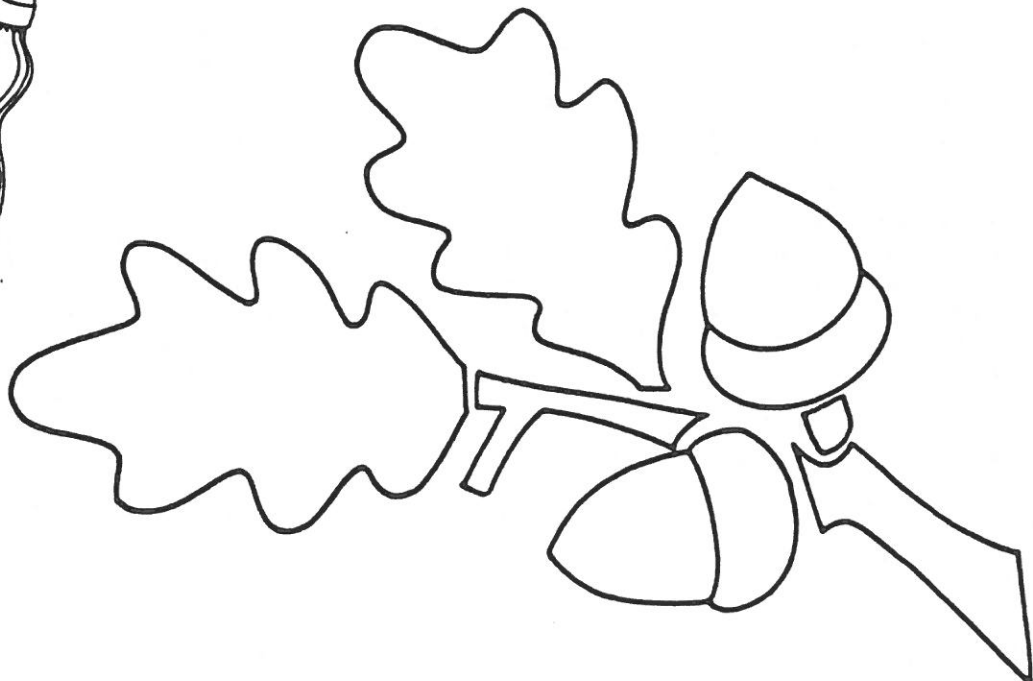
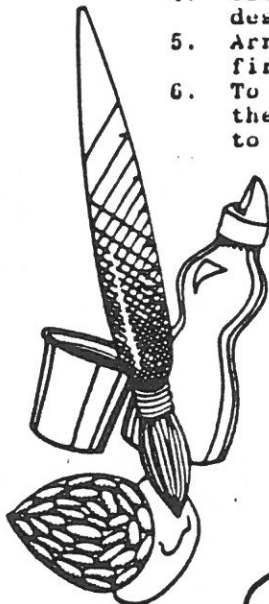

PAGE 4 AUGUST OUTDOOR FESTIVAL



CRAFTS CONTINUED

These accessories will make a picnic more enjoyable.

CORN POPPER

For the handle, remove the hook from a wire coat hanger and straighten the remaining wire. Bend this wire in half; bend the ends of the wire out about 1" from each end.

For the popper, use two foil pie pans. Place them together rim to rim. Using fine wire, attach the bent ends of the handle to one side of the popper as shown. Punch holes for wire through both rims; twist ends of wire to hold handle securely. To hold popper closed while in use, secure rims opposite handle with a metal spring clamp.

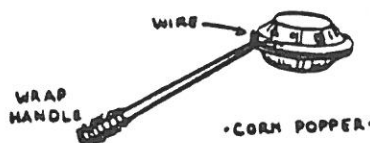

Tape the other end of the handle and wrap it with pipe cleaners to protect the hands from heat.

SANDWICH TOASTER

Use a wire coat hanger; remove the hook, straighten the remaining wire and bend in half. To hold the sandwich, use two round metal lids, approx. 4½" across.

Cut out the center of each lid, as shown, leaving the rim. Wire a rim to each side of the coat hanger about 1½" from the bend. Have each rim between the hanger wires with tops of rims facing the sandwich.

For a handle on each end, bend another piece of hanger wire about 13" long. Tape each handle in place, wrapping it with pipe cleaners. Before using the toaster, burn any paint off the rims.

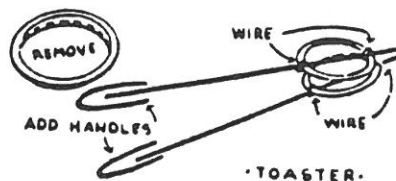

Place sandwich between rims holding handles together firmly while toasting.

PAGE 5 AUGUST OUTDOOR FESTIVAL

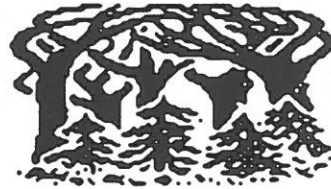

CRAFTS - CONTINUED

SOLAR GRILL

It only works when the sun is shining brightly and is hot.

Cut a triangle of flexible cardboard, and cover it very smoothly with aluminum foil. Bend the triangle carefully into a smooth cone.

Stick a hot dog on a wire or thin stick through the bottom of the cone and into the ground, pointing in such a way that the cone points directly into the sun.

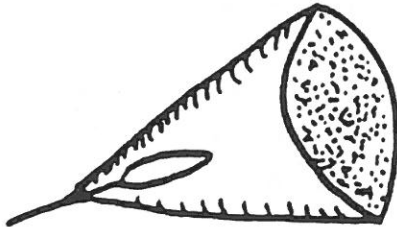

If the sun's rays are strong enough, the hot dog will begin to ooze its fat.

SURVIVAL KIT

Would you believe that all of the items listed below will fit in a 35 mm film can? This is easy to carry and will contain those often forgotten items which you need at meetings.

INSIDE

- 1 pc. chalk
- 4 paper clips
- 1 stub pencil
- 2 dimes
- 4 aspirin
- 2 antacid tablets
- 2 stamps
- 6 straight pins
- 2 safety pins
- 2 thumb tacks
- 1 black crayon
- 1 red crayon
- 1 Bandaid
- 1 razor blade
- 1 piece of string
- 1/3 book of matches
- 2 kitchen matches

OUTSIDE

- 2 rubber bands
- 1 piece of masking tape
- 1 piece of sandpaper on bottom for striking match

And there will still be room for:

- 1 gallon of Good Humor
- 2 pounds of Laughter
- 1 yard of Twinkle (for eye)
- 1 barrel of Fun
- 1 bushel of Patience
- 1 cubic foot of Wisdom
- 1 bucket full of Thankfulness
for the Boy Scouts of America

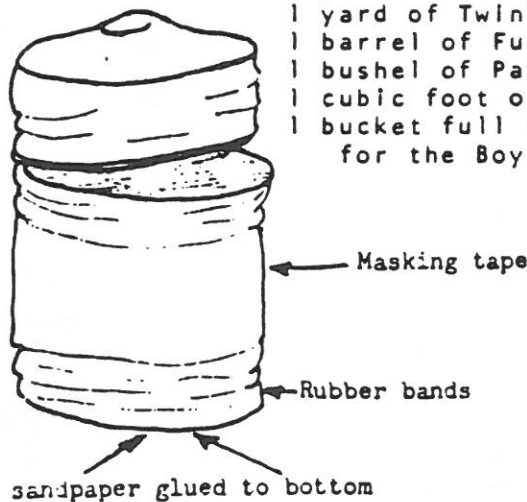

**PAGE 6 AUGUST
OUTDOOR FESTIVAL**



SONGS

BEAR HUNT

Going on a Bear Hunt
A Mighty, Mighty, Bear Hunt
Walking through the woods

*I see a great big tree
*I see a stream
*I see a sticker bush
*I see a wheat field

I see a cave
Let's go inside
It's dark in here
I feel something **BIG & FUZZY**
**IT'S A BEAR! LETS GET OUT OF
HERE!**

(Go back through the wheat field-
sticker bush, stream, tree "FAST")

**CUBS WHISTLE WHILE THEY
WORK**
*TUNE: Whistle While You
Work*

Cubs whistle while they work

(Whistle)

They pitch right in, and
laugh and grin,
And whistle while they work.

Cubs hum a merry tune!

(Hum)

They hum all day at work and play.
They hum a merry tune.

Before they join the Scouts,
They have to know the rule
Of being courteous and kind
In both their home and school

Cubs Whistle while they work,
(Whistle)

They do their bit, they never quit,
Cubs whistle while they work.

HUMBA HUMBA

**HUMBA - HUMBA
TICKIE- TICKIE -TUMBA
MOOSEY - MOSEY - MOSEY
HAY-ALL THE WAY - ALL THE
WAY - ALL THE WAY**

DID YOU EVER SEE?
*TUNE: The More WE Get
Together*

Did you ever see a sunset, a sunset,
a sunset?
Did you ever see a sunset, a sunset
like that?

Additional verses:
Catfish, cowslip, boardwalk, horse
fly, tooth pick, neck tie, nose drop,
butter fly

THINK BLUE
*TUNE: My Bonnie lies over
the ocean*

Think Blue and you're thinking of
Cub Scouts
Think Blue and you're thinking of
boys
Think Blue and you're thinking of
families
Of outings and picnics and joys

Chorus
Think Blue - Think Blue
Think Blue of our Bobcats and
Wolfs and Bears
Think Blue - think Blue
First Webelos then Scout badge
they'll waer.

**PAGE 7 AUGUST
OUTDOOR FESTIVAL**

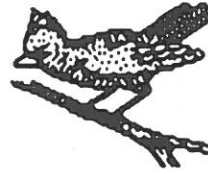

SONG CONTINUED

**IN THE BACKYARD
TUNE: *Clementine***

**In the backyard, in the backyard
You will find your summers fun,
If you look at what's around you
You'll have fun till day is done.**

**After sunset, watch the stars shin
Nture's wonders you can see
Mother Nature's backyard's endless
Always there for you and me.**

**Did you ever watch an ant work?
Have you listened to the bees?
Have you watched birds build their
nest high?
And been thankful for the trees?**

**If you'll just look all around you
Many new things you will find
If you'd only realize it,
They were right there all the time.**

**SEE PAGE 8 FOR CRAFT AND
GAME COMBINED**

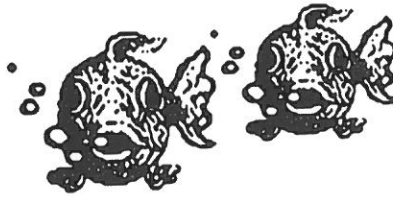

CRAFT AND GAME

MINATURE GOLF COURSE

Set-up a five hole minature golf course. Paint and decorate the following structures and set them in front of the holes.

To make golf holes, set shallow cans just below the ground level. For portable holes above the ground, make ramps with holes in the center. To do this, cut a 15" circle from lightweight cardboard; cut out a 4" wedge from one side and a 4" circle from the center, as shown. Tape the cut edges of the wedge together on the underside.

WINDMILL:

Remove the handle from a gal. milk carton and staple or tape the opening shut. Cut vanes, as pictured, from cardboard. Punch a hole in the center of the vanes and insert a paper fastener. Glue the prongs of the paper fastener on either side of the peak at the top of the carton.

A FIVE-HOLE Golf Course can be set up right in the back yard for the kids to use and enjoy.

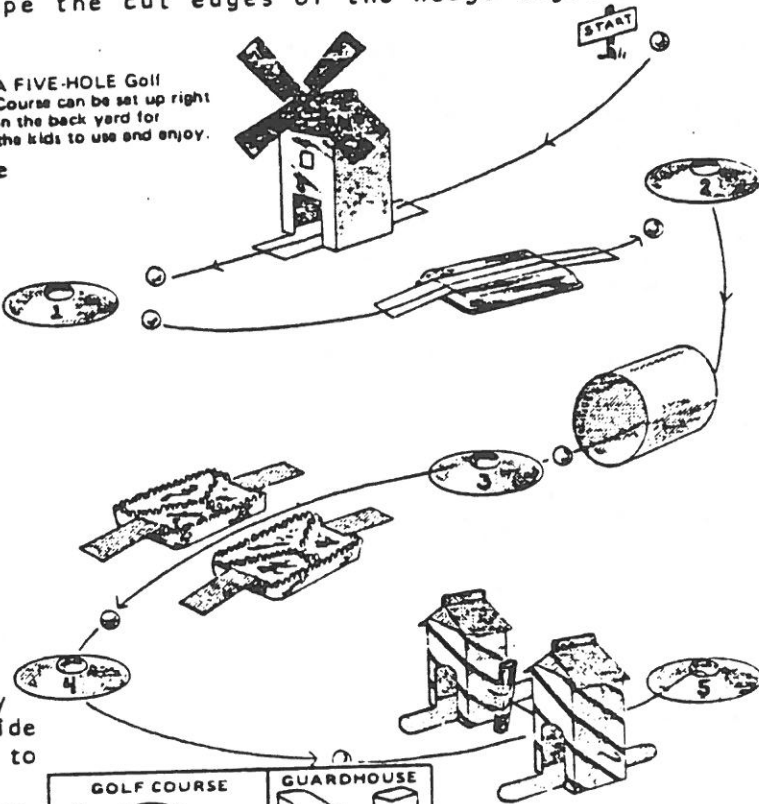

Draw doors on front and back of carton. Cut the doorways along the sides and tops to make flaps. Fold down the flaps to make ramps, and nail them to the ground.

BRIDGE:

Invert a foil pan. Use heavy cardboard to make ramps 3" wide and 6" long. Tape the ramps to the top edge of the inverted pan. Glue a cardboard path on top of the bridge.

TUNNEL:

Cut off both ends from a gallon round plastic bottle.

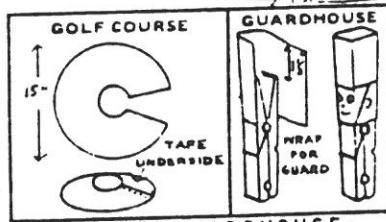

GUARDHOUSE:

SWAMP:

Paint 2 foil pans black. Thread green yarn on a needle. With needle punch holes along the rims of the trays and make loops of yarn for grass. Make ramps for both swamps as you did for the bridge. Place the swamps 5" apart and fill with water.

Use 2 1/2 gal. milk cartons, cut a flapped door in each as you did for the windmill. Make roofs from cardboard.

For the guard, use a clip clothespin. Wrap paper around the prongs (his head), letting the paper extend about 1 1/2" beyond the prongs; glue to hold. Cover the top of his hat with paper.



**SEPTEMBER
OUR AMERICAN
HERITAGE**

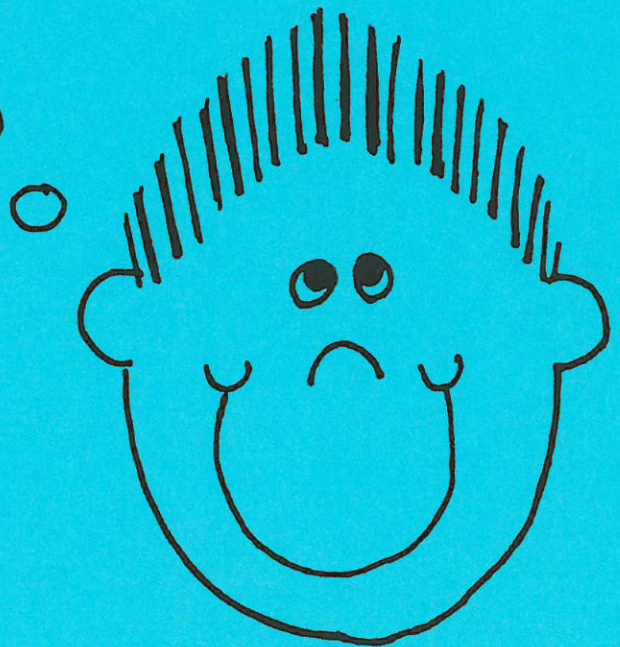



SEPTEMBER OUR AMERICAN HERITAGE



OPENING

I AM AMERICA'S HERITAGE

BY: Robert Bartlett, Orlando

Setting: Room is darkened. Pack flag and American flag are spotlighted. Patriotic background music is played.

NARRATOR: There it is - It's still flying. It has been a long night and as the dawn appears and the smoke clears, it is fluttering in the breeze.

I am the American Revolution and the valiant patriots that lost their lives that this nation might live.

I am Paul Revere and his midnight ride.

I am Nathan Hale and his stand for freedom.

I am George Washington crossing the Delaware.

I am the Boston Tea Party and Bunker Hill.

I am Kings Mountain and Guilford Courthouse.

I am the Constitution of the United States, the Bill of Rights, and the symbol of religious freedom.

I am the War of 1812 and the Mexican War.

I am the Alamo and the Battle of Bull Run.

I am the Battle of Vicksburg and the blood and torment of the Civil War.

I am the Monroe Doctrine and the

Spanish American War.

I am World War I and the depression of 1929.

I am Pearl Harbor, World War II, the Korean conflict and Vietnam.

I am the pain and sorrow, the happiness and joy of bygone days.

I have seen poverty and wealth, dread and anticipation, hate and love.

I have seen America through all her history.

I am America's Heritage

(As Narrator finishes, volume of background music is turned up)

WE THE PEOPLE

BY: Doug Kroll

Setup: Have individual, den or entire group recite Preamble of the Constitution of the United States of America.

WE THE PEOPLE of the United States, in order to form a more perfect Union, establish justice, insure domestic tranquility, provide for the common defense, promote the general welfare, and secure the blessings of liberty to ourselves and our posterity, do ordain and establish this constitution for the United States of America.

PAGE 2 SEPTEMBER OUR AMERICAN HERITAGE



OPENINGS CONTINUED

THE AMERICAN CREED BY: DOUG KROLL

NARRATOR: "The American Creed was adopted by an act of Congress on April 6, 1918. As we listen to its words let us rededicate ourselves as loyal citizens of this great land."

THE AMERICAN CREED

I believe in the United States of America, as a government of the people, by the people, for the people; whose just powers are derived from the consent of the governed; A democracy in a republic; a sovereign nation of many sovereign states; a perfect union, one and inseparable; established upon those principles of freedom, equality, justice and humanity for which American patriots sacrificed their lives and fortunes.

I therefore believe it is my duty to my country to love it, to support its constitution to obey its laws, to respect its flag, and to defend it against all enemies.

THE UNITED STATES BY: Doug Kroll

The United States is a country rich with heritage: from the Declaration of Independence and the U.S. Constitution, which declare our freedom, to the Statue of Liberty, which shines the light of freedom to the world.

The United States is also a country rich with Spiritual heritage, from the motto "In God We Trust" on our coins to the words "One Nation

Under God" in the pledge of allegiance to our flag.

The Cub Scout Promise reflects that heritage with its reference to our "Duty to God"

Let us recall our nation's heritage as we join in saying the Cub Scout Promise.

RECIPE

Use this recipe as the basis for a ceremony.

- 1 cup friendly words
- 2 heaping cups understanding
- 2 cups milk of human kindness
- 2 heaping tbsp. time and patience
- 1 dash gentle humor
- 1 pinch of spice of life
- 1 drop warm personality

Measure words carefully. Add cups of understanding to milk of human kindness. Sift together three times to make a smooth paste. Cook with gas on the front burner. Keep temperature low so it never boils over. Season with gentle humor, warm personality and spice of life. Serve in individual molds.

FREEDOM

San Diego Council

A Cub Scout stands blindfolded, gagged and bound before the audience. The Cubmaster says:

"This is an American boy. The American Revolution won him freedom. (Cubmaster unbinds him) The Constitution guarantees him free speech. (Removes Gag) A free education gives him the ability to see and to understand. (Removes blindfold) Let us help Cub Scouting teach him to persevere and enjoy this glorious heritage and to become a good citizen." (Turn on lights, Spotlight American Flag do Pledge)

PAGE 3 SEPTEMBER OUR AMERICAN HERITAGE

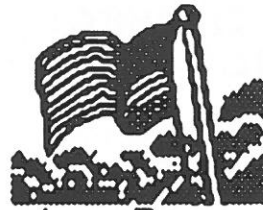

LIBERTY BELL

PERSONNEL: Den Chief, 6 Cub Scouts (You have more boys available, breakdown narration into more speaking parts)

ARRANGEMENT: Large Poster of replica of Liberty Bell on stage. Cub Scouts are off stage. In turn, they come on stage, carrying a large sign with the appropriate date and recite their parts.

DEN CHIEF: One of the most cherished symbols of American Independence is the famous Liberty Bell, now preserved in Independence Hall, Philadelphia. It has been rung on a number of important occasions some of which we'd like to tell you about.

1st CUB: On July 4, 1776, the bell was rung to announce the official adoption of the Declaration of Independence. This was actually the birthday of our nation and marks the most important single event in our history.

2nd CUB: On October 14, 1781, It was rung to celebrate the surrender of Lord Cornwallis of the English forces, and the virtual close of the Revolutionary War.

3rd CUB: On September 29, 1824 It was rung to welcome Lafayette, the famous French general who had assisted Washington, to Independence Hall. On July 4, 1826 it tolled to announce the death of Thomas Jefferson, Principal author of the Declaration of Independence.

4th CUB: On July 14, 1826 it ushered in "The Year of Jubilee" the 50th anniversary of the American Republic. On July 4, 1831, the famous bell rang for the last time

on Independence Day.

5th CUB: On February 22, 1832 the bell was rung to commemorate the birthday of George Washington. Later that same year it tolled to announce the death of the last surviving signer of the Declaration of Independence, Charles Carroll of Carrollton, Georgia.

6th CUB: On July 8, 1835 while it was being tolled for the death of Chief Justice John Marshall, a crack developed in the bell. On February 22, 1843 when an attempt was being made to ring the bell on Washington's birthday, the fracture increased to such an extent that no effort has been made to ring it since that time.

DEN CHIEF: Some of you may have been to Independence Hall to see the Liberty Bell. Perhaps you remember the inscription "Proclaim Liberty Throughout the Land", from which the bell got its name.

OPENING AND ADVANCEMENT CEREMONY

Cubmaster seated at desk, ready to anchor the 6 o'clock news (could be called Walter Crankcase)

CUBMASTER: Good evening everyone, in tonight's news there is a Pack meeting for Pack _____ which is to begin, with the presenting of the colors and the Pledge of Allegiance. Let's go there now by means of our minicam to see it live as it happened. (Cub Scout Honor Guard presents the Colors and leads the Pledge of Allegiance)

CUBMASTER: And so there under way having another evening of fun and enjoyment in Cub Scout Pack Meeting with Pack _____

PAGE 4 SEPTEMBER OUR AMERICAN HERITAGE

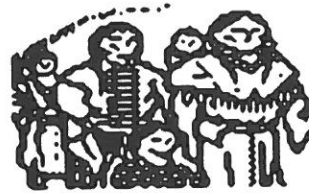

NEWS CONTINUED

Let's now go to our reporter on the street who has a member of the Honor Guard for an exclusive interview.

REPORTER: (Could be Den Chief or Den Leader) I have with me here (give name), of the Honor Guard who presented the Colors at tonight's Pack Meeting. Could you tell us how you feel when the flag of the United States is presented to open the evening?

CUB SCOUT: It is a thrilling thing to be able to present the flag for everyone to see and to repeat the pledge. It makes me feel like it's a great honor and privilege to live in this great country and to enjoy the freedoms that our beautiful flag represents.

REPORTER: Thank you _____ and now back to you Walter.

CUBMASTER: In other news tonight, some of the Cub Scouts have been working hard with their parents to earn advancement with new rank advancements and arrow points or activity badges. Lets return to the Pack Meeting for that presentation, live as it happens.

(PRESENTATION OF AWARDS)

And so you have now witnessed the greatest news event of the evening, Live, here on the Crankcase news.

CLOSING

CUBMASTER: We have witnessed a very impressive evening of Cub Scouting at it's very best tonight here on the Crankcase news. But before we tell you good night let's

recap the events of the Pack meeting we have attended.

CUBMASTER: Awards for the best 30 second commercial went to Den _____ with Den _____ taking the second. The best mini-drama award went to Den _____. Advancements tonight included _____.

We want to let you know that some day, one of these boys will have my job as new anchorman, because Dan Lather can't live forever. In a more serious tone, then let's witness the retiring of Old Glory and the precision of the Cub Scout Honor Guard who have been especially trained for this special part of the Pack Meeting. (Retire Colors)

Thank you for joining us here this evening, this is Walter Crankcase saying good evening and that's the way it is at Pack Meeting this (give date) good night.

TIE-INS

The support neede for this type of porgram would include skits by Dens that are commercials about something the boys are interested in and can be written by them, hopefully satirical and mini-dramas or spoofs on famous T>V> or movie shows. The presentation of the Colors, Advancements, and closing should be on a more serious tone, but remainder could be as jovial as you dare.

New anchorman must present himself in a believable tone, with a great deal of dignity. Set could be on stage with lights and a frame to give the appreance of a television screen. Reporters need a different screen.

PAGE 5 SEPTEMBER
OUR AMERICAN HERITAGE



SKITS

NO DEAL
SAN GABRIEL VALLEY

Characters: One Well padded
Indian
One bystander
Three to five tourists

The scene opens with an Indian standing with a blanket over his arm with a "For Sale" sign on it. Tourists approach.

TOURIST #1: Say, Chief, I'll give you \$5.00 for that blanket

CHIEF: NO DEAL!

TOURIST #2: I'll give you \$10.00 for it.

CHIEF: NO DEAL!

(Tourist gather around and bid—\$12.00, \$15., \$18. \$20, \$22, and finally..)

TOURIST #1: Chief, I'll give you \$24.00 for that blanket.

CHIEF: NO DEAL! UGH! (tourists leave, bystander approaches)

BYSTANDER: Say Chief, why wouldn't you sell that blanket to any of those tourist?

CHIEF: What do you expect—deals like Manhattan Island every day?

THE DEATH OF CHIEF
SHORTCAKE

Characters: Chief Shortcake (volunteer dad with good sense of humor)

Sqaw
4 Braves

ANNOUNCER: At a great gathering of the tribes, Chief Shortcake has died. Four braves are discussing his funeral.

1st Brave: In the custom of the Algonquin, we must build a log house, place the chief and his

possessions inside, burn it and cover it with earth so his spirit will not be robbed.

2nd Brave: No, in the custom of the Seminole, we must place him in a canoe and send him on his journey to the Great Waters.

3rd. Brave: Oh, no, as with the Yakima, we must cover the chief's body with boulders and rocks so his ghost will not escape to harm us.

4th Brave: We must build a funeral bier and burn the chief as the Cheyenne do. This way his spirit may join the Great Spirit.

(ENTER SQA W)

SQUAW: You all wrong. SQUAW .
BURY SHORTCAKE!

(As she speaks, she squirts whipped cream on face of chief and tops it with a cherry)

(Have a wet towel ready fo the chief)

SONGS

FLY YOUR FLAG

TUNE: Row, Row Row Your Boat

Fly, fly, fly your flag,
On our Holidays,
Be a loyal Citizen,
In this and other ways.

THE TREE HOUSE

TUNE: Clementine

In the backyard, in the backyard
In a great big tall oak tree
That is where we built our tree house
Hidden so no one can see.

Secret codes and secret meetings
Just a few friends can belong.
No one knows our secret password
On our secret Cub Scout song



See Next page
SONGS CONTINUED

THE TREE CONTINUED

If you're old enough, you can join us
In our tree house with the rest
You can also be a Cub Scout
If you always do your best.

SINGIN IN THE RAIN

CHORUS:

Tumbs up	Elbows Back
Knees in	Toes out
Check out	Buns back
Neck down	Tongue out

Too-te-tah — etc

BOY SCOUTS

We are all Boy Scouts as you can
plainly see, but if I weren't a Boy
Scout (chorus)

1. A carpenter I'd be—and as
you pass me by you would hear me
cry

2 x 4 nail it to the floor(2x's)

chorus

2. A bird watcher I would be
and as you passed you would hear
me cry

Hark a lark flying through
the park splat (4x's)
2 by 4 nail it to the floor(2x's)

chorus

3. A plumber I would be and as
—etc

plunge it, flush it look out
below(6x'2)

Hark —(4x's)
2 by 4 —(2x's)

Chorus

BOY SCOUTS - CONTINUED

4. A stewardess I would be
as—etc.

coffe, tea or me sir. here your
paper bag yuck (8 x's)

plunge it —etc(6x's)

Hark— etc(4x's)

2 by 4 — etc(2x's)

Chorus

5. An ice cream maker I would
be and as — etc

ooshy, gooshy good ice cream
(10 x's)

repeat prior

Chorus

6. A Farmer I would be — etc
Thars a cow and thars a cow

and thars another yuck (12x's)
etc

Chorus

7. A hippie I would be —etc
love, peace, my hairs full of

grease (14x's)
etc

Chorus

8. A Girl Scout I would be—etc
buy a cookie, try a cookie, get

one for free (16x's)
etc.

OR

A little girl, I would be —etc
Mommy, daddy I love you
(kiss) (16x's)

LEADER RECOGNITION CLOSING

PROPS: Large gold stars with a
hole in center of each - large
enough for each boy to poke his
head through. Star is frame around
face.

Each boy, in turn repeats the
following speech:

"My star represents your __(office)_.
Mr/Mrs_____ and his/her assistant,
Mr/Mrs_____. When all have done
this, then all repeat in unison,
"On behalf of all the Cub Scouts, we
wish to say thank you for the
leadership you have given our pack"

**PAGE 7 SEPTEMBER
OUR AMERICAN HERITAGE**



PARENT INDUCTION CEREMONY

CUBMASTER: (TO PARENTS) In Cub Scouting, parents are inducted just the same as the boy. A boy takes upon himself an obligation or promise that he will do his best, that he will help other people, and that he will obey the Law of the Pack.

Now, I would like for you parents to assume an obligation that you might be better leaders of your sons. Sometimes an unusual position taken when assuming a promise, will make the promise more easily remembered. So I'll ask each of you to bend over and place a hand on each of your knees.

NOW REPEAT AFTER ME:

I, (your name) promise to do my best to be a good parent to my son.

I promise to work with him in the home and help him earn his awards.

I promise to attend Pack meetings and keep his interest high.

I promise to gain useful knowledge and to impart it to my son.

I promise to cooperate with the Den, the Pack and the leaders
AND KNOW,

I know in my heart
I know in my mind
I know that I
Stick out behind.

BOBCAT INDUCTION CEREMONY

PERSONNEL: Bobcat candidate, his parents, Cubmaster

EQUIPMENT: 1" x 6" board, two nails, two strings 18 inches long, two metal washers

BOBCAT INDUCTION - CONTD

ARRANGEMENT: Drive a finishing nail into each end of the board, slightly off center, with 1/4" left protruding. Print **ACHIEVEMENT** on one side of the board and **PARENT COOPERATION** on the other side. Tie a washer to one end of each of the strings.

Ask the Bobcat Candidate to take the string and the washer and lift up the board from the floor by engaging the washer over the nail. It will slip off.

Ask the Bobcat's parents to try the same thing, with the same string.

When they have tried and failed, pull the other string out of your pocket and give it to the boy. Tell him and his parents to put a washer on each nail and together pull the board up. Together, they should succeed. The board should flip so the words can be seen.

Explain that achievements in Cub Scouting will always depend on the Cub Scout and his parents working together, just as they have done tonight.

WEBELOS INDUCTION CEREMONY

EQUIPMENT: Individual large Cards spelling **W E B E L O S**; The Webelos hat, neckerchief, slide, and book.

WEBELOS LEADER: Before we induct Cub Scout (___Name___) into Webelos, my Den would like to tell you some of the things we do as Webelos.

1st WEBELOS: "W" - We develop new interests and skills by working

PAGE 8 SEPTEMBER OUR AMERICAN HERITAGE



on our achievements in the 20
WEBELOS INDUCTION - CONT'D

activity badge areas.

2ND WEBELOS: "E" Everyone of us tries to develop good habits and attitudes of good citizenship as we continue to grow in mind, body and spirit.

3RD WEBELOS: "B" - By learning our Scout requirements before we are all 11 years old, we can join a Boy Scout Troop immediately after we graduate from Cub Scouts.

4TH WEBELOS: "E" - Each of us learn the rules of good sportsmanship and we respect the rights of others.

5TH WEBELOS: "L" - Lots of games and exciting new things to do, make our Den meetings lots of fun.

6TH WEBELOS: "O" - Only by being helpful and doing our best can we live by our Cub Scout ideals.

7TH WEBELOS: "S" - Since we are proud to be Webelos, we would like to hear our cheer.

ALL WEBELOS: W E B E L O S
WEBELOS!

WEBELOS LEADER: Will Cub Scout _____ and his parents please come forward. Will the Webelos Denner and the Assistant Denner please bring the Webelos items forward. Will you assist Mr and Mrs. _____ dress their son's Webelos uniform.

Thank you Denners

This Webelos book is for you son but this supplement is for you. It will help you better understand the Webelos Program. You will note that your son will be working in activity badge areas. I will be calling upon you to help out in one or more of these areas during the

year.

WEBELOS INDUCTION - CONT'D

Will Den Chief _____ please escort our new Webelos Scout and his parents back to our Den. Thank you.

RESOURCES: Ceremony boards can be found in you Cub Scout Leader How To Book and you Cub Scout leader book.

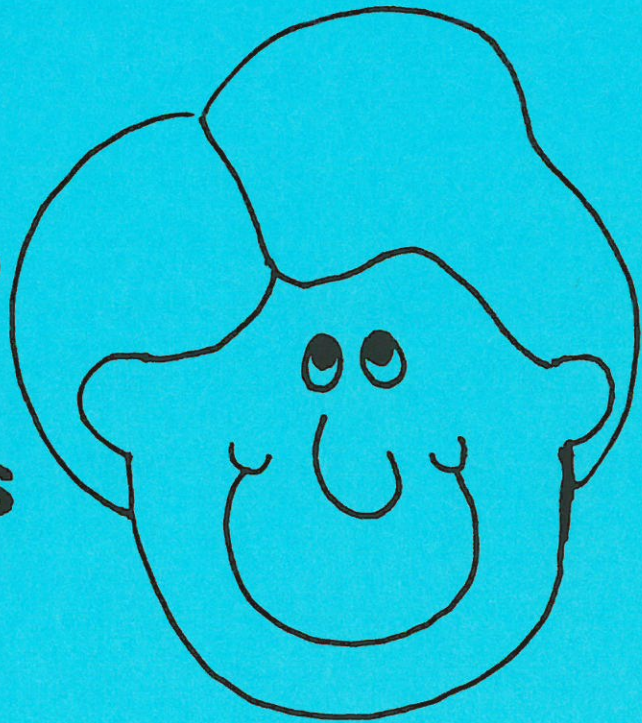
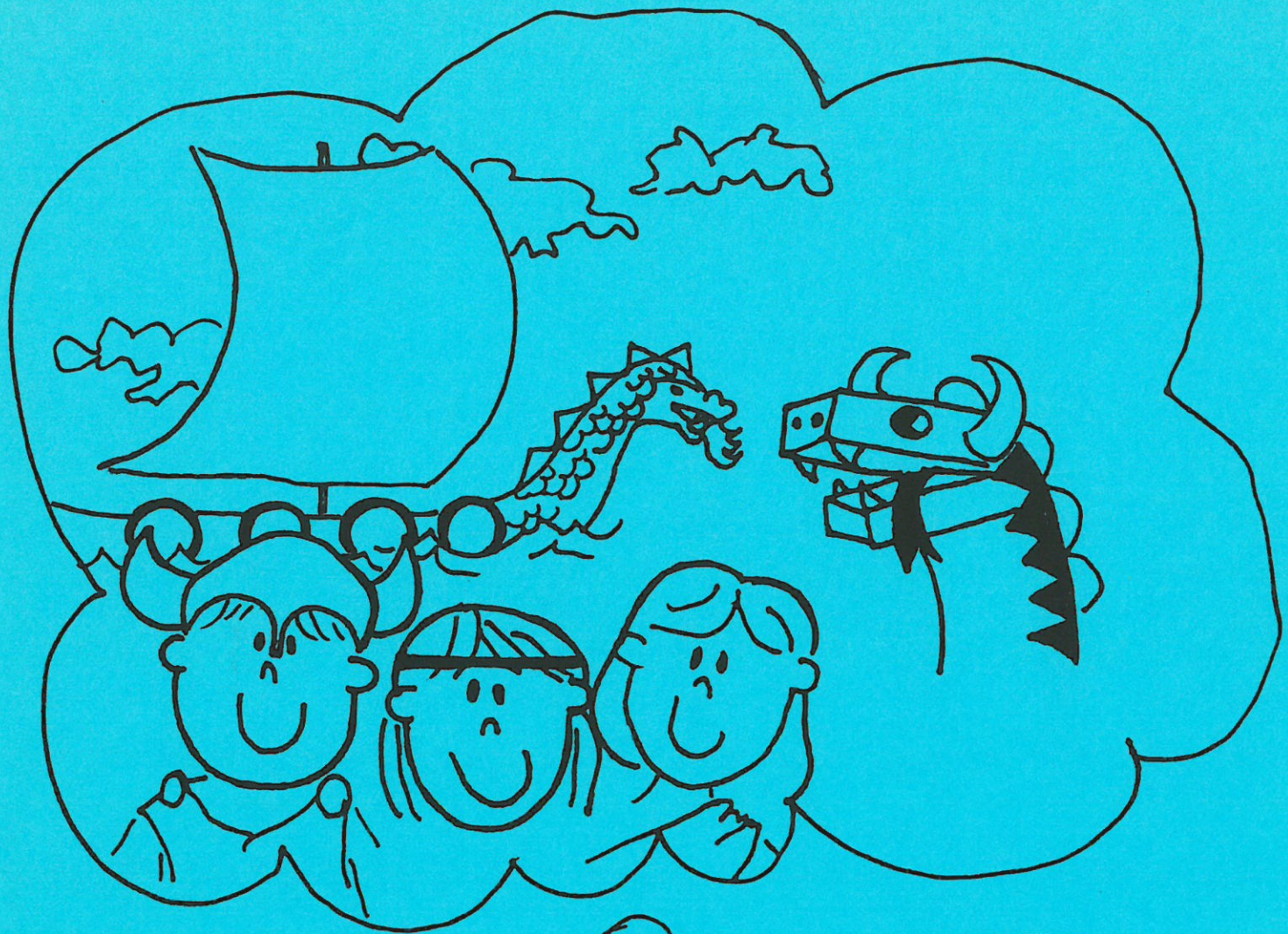

**OCTOBER
VIKING DISCOVERIES**

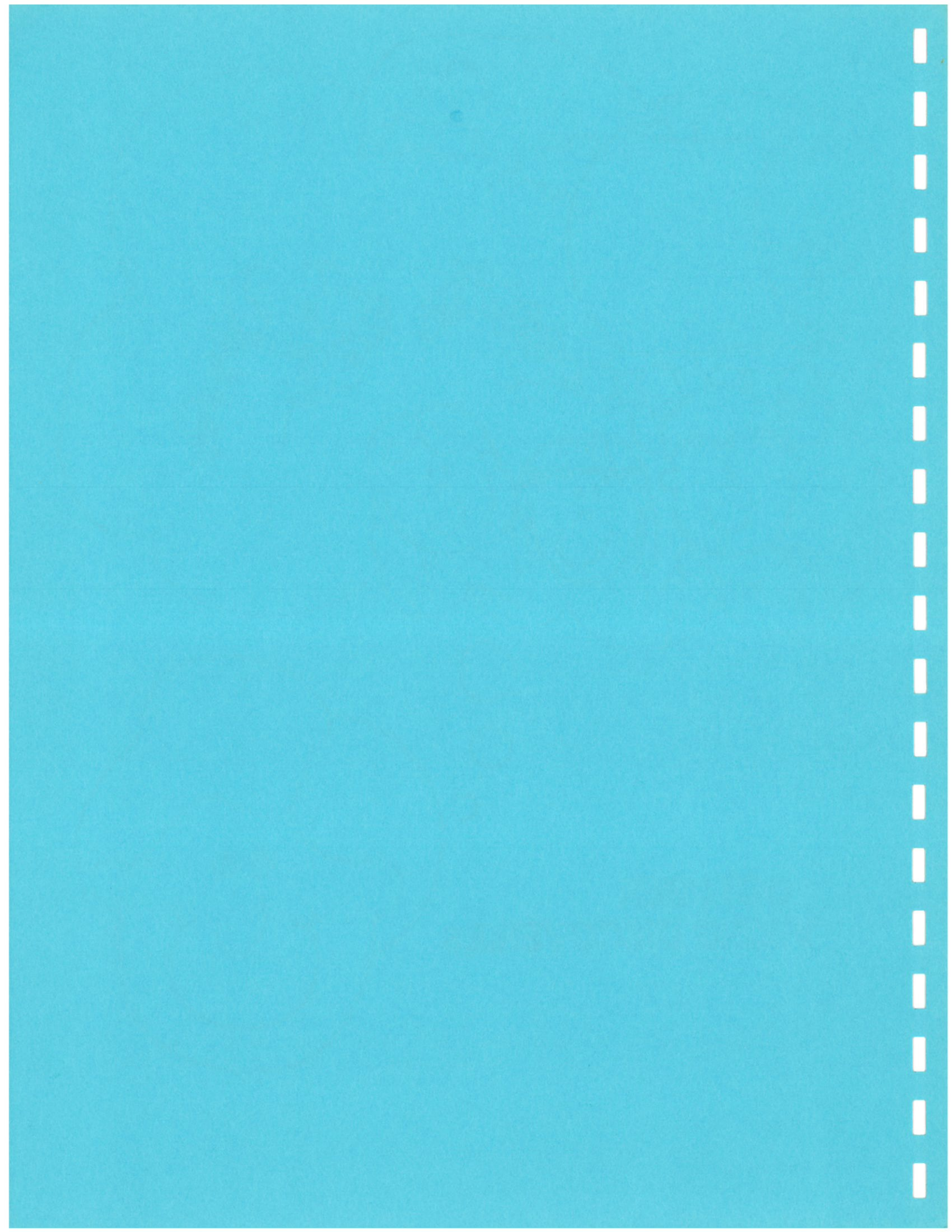

OCTOBER VIKING DISCOVERIES



OPENING

VIKING DISCOVERIES

- V is for their victory in making new discoveries
- I is for their interest to search through the world
- K is for their key to adventure
- I Is for individuals who claimed new lands
- N Is for their Norse background
- G Is for their claiming of Greenland
- S Is for the ships the Vikings built.

In about 860, the Vikings discovered Iceland. It was cold and harsh with volcanoes, icesheets and glaciers. Luckily, the lakes and rivers were full of trout and salmon

In 982 Erik the Red discovered Greenland. It was even icier and more barren than Iceland. The Grenlanders came to be great traders and fishermen. They wandered further west and discovered America in about 986.

The Vikings were excellent craftsmen and built large sailing vessels called longships. They were bigger than any ships in the county.

VIVKING SKIT

The Vikings have just boarded the longship for a new voyage to last several months. Thor is pacing with excitement, walking up and

down the length of the ship. As Thor passes, Viking 1 holds his nose and leaves the ship. Thor walks by again and Viking 2 holds his nose and leaves the ship. Thor continues and each time he passes another Viking leaves the ship. (Use as many Vikings as needed to give each Scout a part.) Soon everybody has left and the Captain, Erik the Red, storms up to talk to Thor.

Erik the Red: Hey you're running all the Vikings off my ship. Now I have no sailors for the voyage.

Thor: Well, it isn't my fault. They can leave if they want to.

Erik the Red: Well, sure, but they seem to detect an odd odor about you. Do you bathe regularly?

Thor: Sure do.

Erik the Red: But, do you use soap?

Thor: Sure do.

Erik the Red: Did you wash your feet today?

Thor: Sure Did.

Erik the Red: Change your socks?

Thor: (angry) Sure I did. And what's more (Holds up a pair of filthy socks, taken from hip pocket), I've got my old ones here to prove it!

CURTAIN

PAGE 2 OCTOBER VIKING DISCOVERIES



CLOSING BY: Win Walker

Do not follow, I may not Lead
Do not lead, I may not follow
Walk beside me and We will be
Friends

SONG VIKING SONG TUNE: *Farmer in the Dell*

I'll mount my ocean steed
And O'er the hills I'll speed,
Forests and hills are not for me,
I love the moving sea.

KING GEORGIE TUNE: *My Country 'Tis of Thee*

King Georgie had a date
He stayed out very late.
For he was King, Queen Mary
paced the floor,
King Georgie came home at four
She met him at the door,
God Save the King.

HALLOWEEN SONG TUNE: *Yankee Doodle*

I'll carve a fearful pumpkin
face,
As well as I am able
And when it's done I'll light
it up
And set it on the table

I'll fix it so that passers by
Will see and get the quivers;
For Halloween's the time to
play
That you have shakes and
shivers

CRAFTS

Material: paper lunch bag (white)
pencil
black paint or markers
masking tape or string
flashlight

1. Draw a ghost face on bag.
 2. Paint or color it with markers
 3. Insert flashlight & wrap with tape or tie with string.
- **Could also be monsters or jack-o-laterns

GHOST MOBILE

Materials: White and orange
construction paper
String or fishing line
Stick
Marker

1. Trace around hand on white paper three times
2. Cut out hands. Also cut out circle of orange paper
3. Draw faces on ghosts and pumpkin
4. Tie with string to stick.

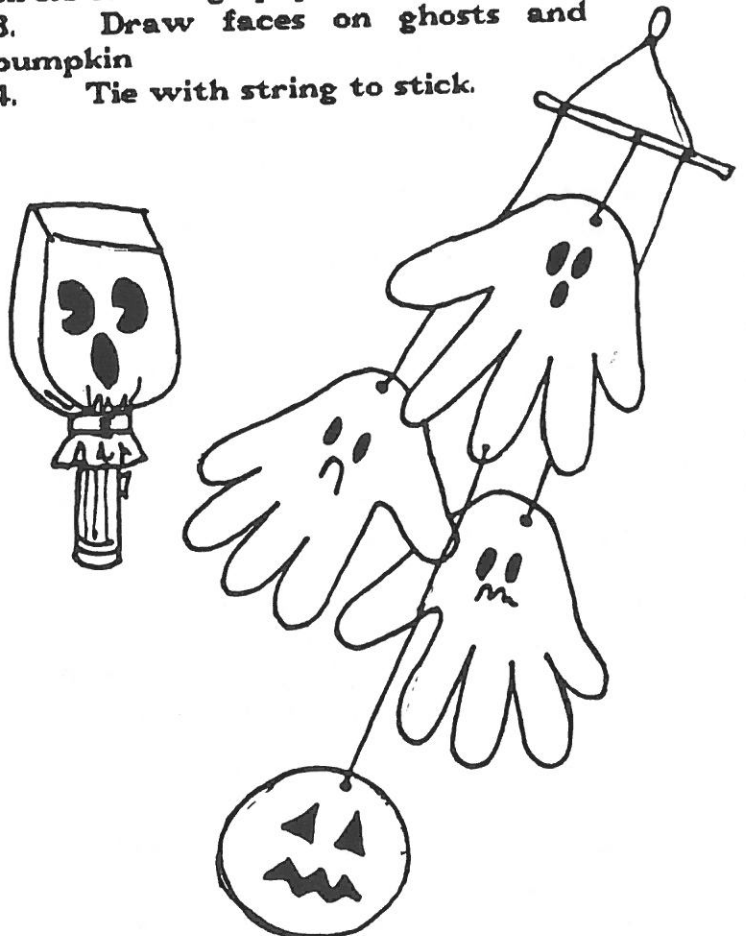

PAGE 3 OCTOBER VIKING DISCOVERIES



CRAFTS - CONTINUED

FLAGS OVER AMERICA - VIKING BANNER

The Viking Banner, carried to the New World in the 10th and 11th centuries, was said to have mystical powers. When carried in battle toward success, the Raven would seem to clap its wings as if in flight. But toward approach of disaster, the Raven would hang down and not move.

To make a pillow like the Viking banner, use pinking shears to cut 2 pieces from an old sheet, as shown.

Place cardboard between the two pieces. Color Raven and trim with black permanent marker (Color will not wash out).

Partially stitch on machine as indicated. Stuff with old nylons, return to machine to stitch up remaining seam. Or stitch by hand.

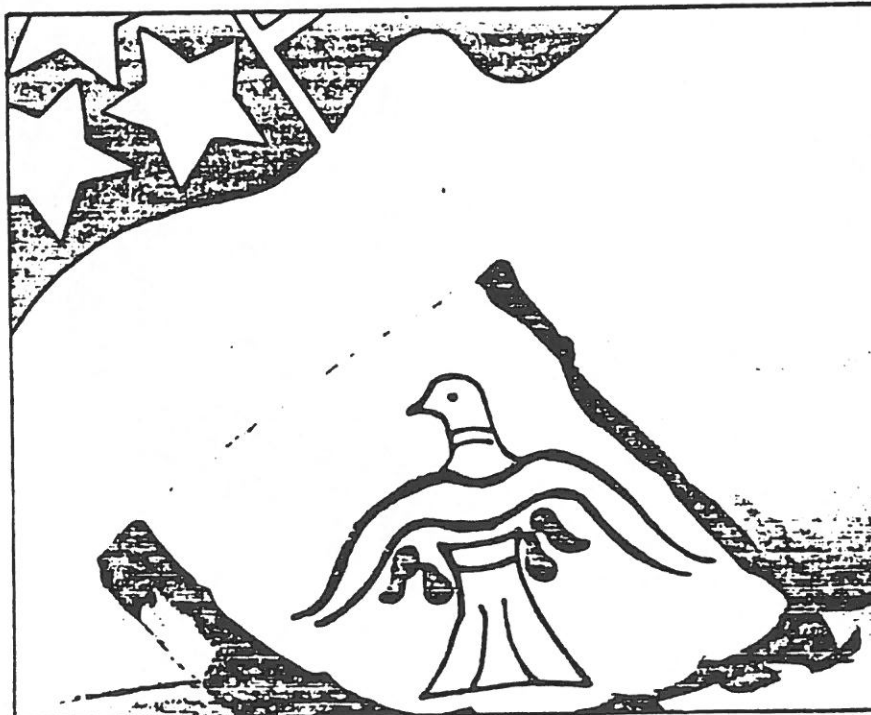
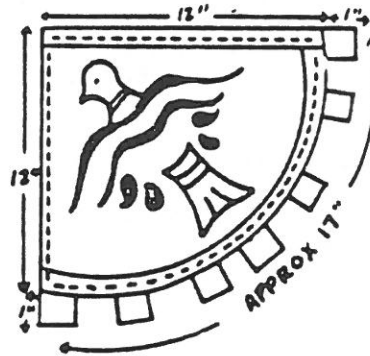

"The Raven"

PAGE 4 OCTOBER VIKING DISCOVERIES



CRAFTS - CONTINUED

SKULL LANTERN

Remove top and handle of a gallon plastic bottle, as shown. (Handle side becomes back of skull)

Cut out the features of the skeleton with a sharp knife. To shape the top of the head, cut six evenly spaced flaps about 1½" deep. Bend down the two flaps on each side first, then the front and back flaps, overlapping them and stapling in position.

If light is desired, insert a Christmas tree light through a hole cut in the back where the handle was.

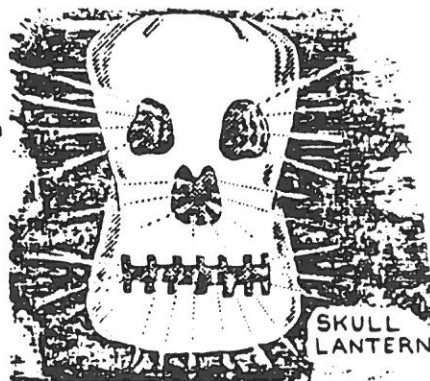

SPOOKY BALLOON DECORATIONS

HORRIBLE HEADS:

From paper cut glaring eyes, leering mouths and pointed odd-shaped ears. Use your imagination to make the facial expressions as frightful as possible. Glue in place. Include small tabs on the ears, so they will protrude when attached to the balloon.

BAT:

Use a wire coat hanger with the ends bent upward for the body of the bat. Cut large wings from paper and tape to the hanger. Use a rounded balloon for the head. Tie string around the neck of the balloon and attach head between the wings by taping the ends of the string to the wings at back. Add paper features and paint details on wings. Use the coat hanger hook for hanging up your bat.

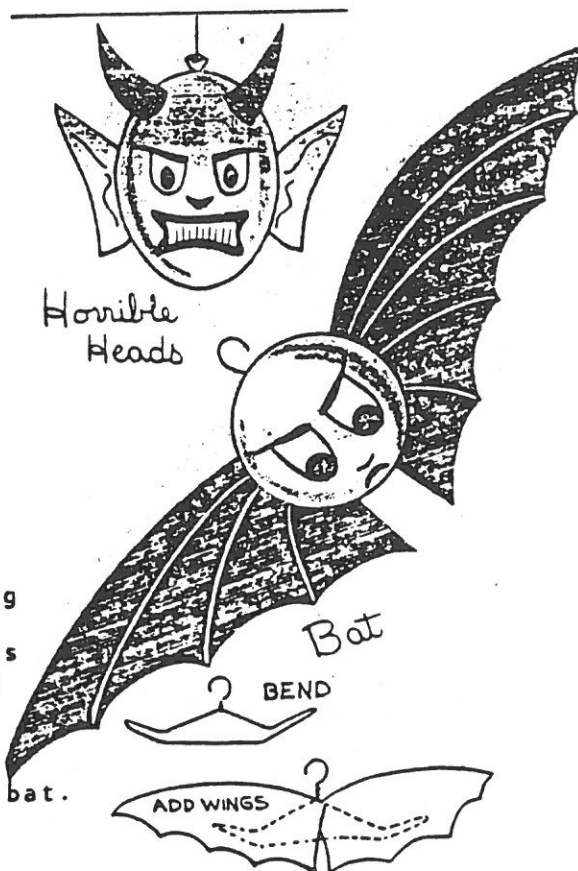

PAGE 5 OCTOBER VIKING DISCOVERIES

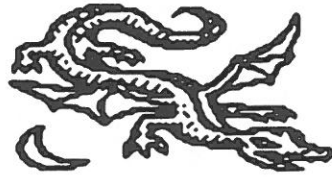

AUDIENCE PARTICIPATION

PEG LEG PETE'S PREDICAMENT

PIRATES: Yo-ho-ho
PEG LEG PETE: Clomp, clomp
TREASURE: Gold! Gold!
MAP: It's That-a-Way

Back in the swashbuckling days of pirates ____ bold, there lived a certain one named Peg Leg Pete _____. His only goal in life was to find a hidden treasure _____ which could be found by following a map _____. Only one copy of the map _____ existed among all the pirates _____, and it happened that Peg Leg Pete _____ had possession of the map _____.

One fine day he and his pirates _____ set sail to find the treasure _____. After carefully studying the map _____ they began their journey. Each one was dreaming of all the riches he would find when they finally located the treasure _____. Peg Leg Pete _____ followed the map _____ day by day, using his spyglass as they came closer and closer to the spot where the treasure _____ was buried. Finally they spotted land and eagerly went ashore. As they approached the spot where the map _____ showed the treasure _____ buried, Peg Leg Pete _____ suddenly threw the map _____ down in a mad rage while the other pirates _____ rushed to pick it up and see what had enraged their leader. In his haste to get to the treasure _____, Peg Leg Pete _____ had been reading the map _____ upside down. The treasure _____ was really buried right in the spot they began their journey.

In a rage, the pirates _____ took out their swords and killed Peg Leg Pete _____, tore the map _____ into shreds fighting over it, and then fought until they all were killed. So the treasure _____ is still buried right where it has always been .. at the end of the rainbow!

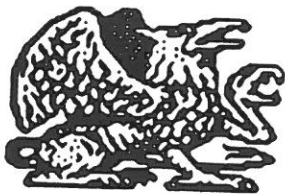

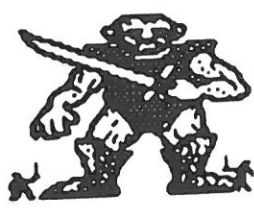

AUDIENCE PARTICIPATION

THE SEASICK WITCH

- WITCH: "Boo-ooo-oo"
- HAT: (Pretend to put hat on head)
- BROOM: (Sweeping motion)
- MOON: (Big smile on face with arms curved over head)
- CAT: "Scree-eech"

Once there was a young witch _____ who lived on the moon _____. The witch _____ had, or thought she had, everything that a good witch _____ ought to have. She had a hat _____. She had a cape, and she had a broom _____. But one thing was wrong. Whenever the witch _____ put on her hat _____ and her cape and got on her broom _____ and flew away from the moon _____, she got seasick. The poor witch _____ had tried three times, but she never had any fun witching around at all.

So, in desperation, the witch _____ decided to go see the oldest witch _____ on the moon, and ask her what to do. The old witch _____ said: "What's the trouble, dearie?" The young witch _____ said: "Every time I put on my hat _____ and my cape and get on my broom _____ and fly away from the moon _____, I get seasick. I never have any fun witching around at all!" She began to cry.

The old witch _____ patted her on the shoulder, and then she said: "Where is your cat _____?" "My cat _____?" "Why yes, dearied. You need a cat _____ on the back of your broom _____ to hold it steady. Then you will fly smoothly when you leave the moon _____." So the young witch _____ put on her hat _____ and her cape, and got a cat _____ and put it on the back of her broom _____ and flew smoothly away from the moon _____. From then on she had lots of fun witching around on Halloween.

So remember, whenever you see a witch _____ flying through the air on her broom _____ you can be sure that she'll have a cat _____ riding along behind her.



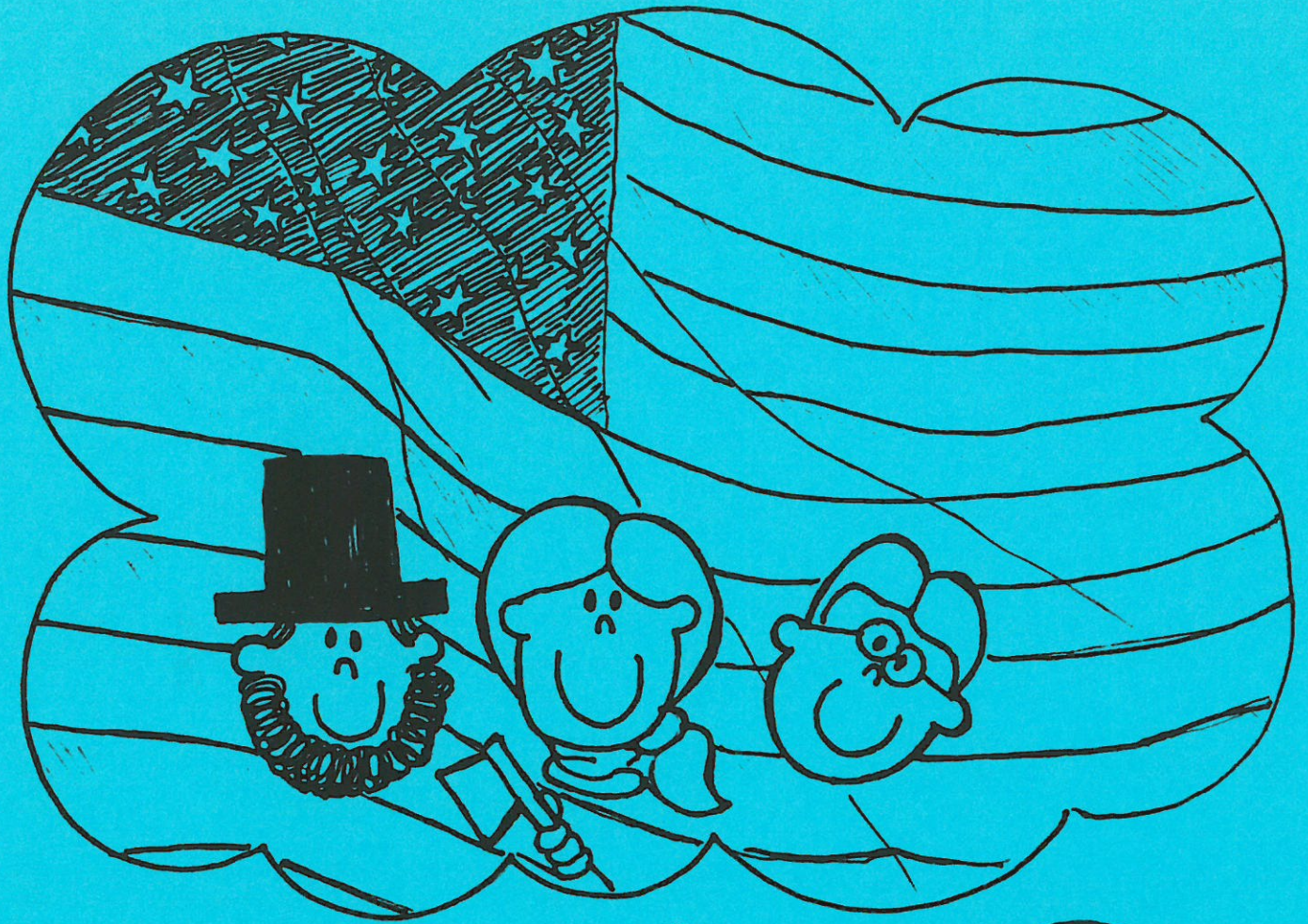

**NOVEMBER
PARADE OF PRESIDENTS**

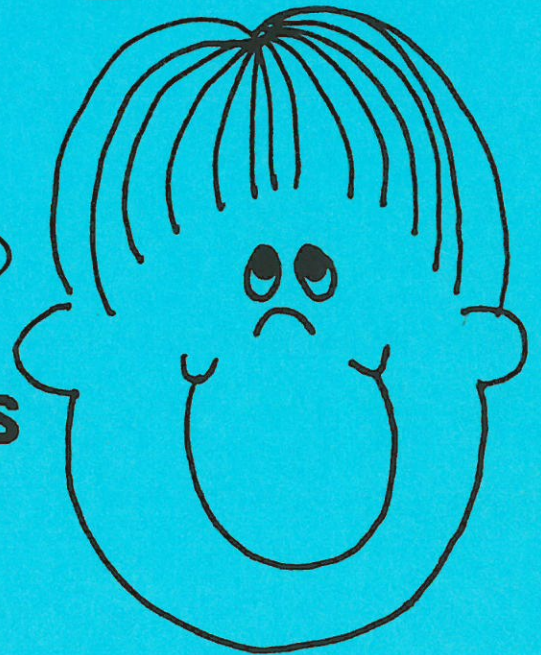

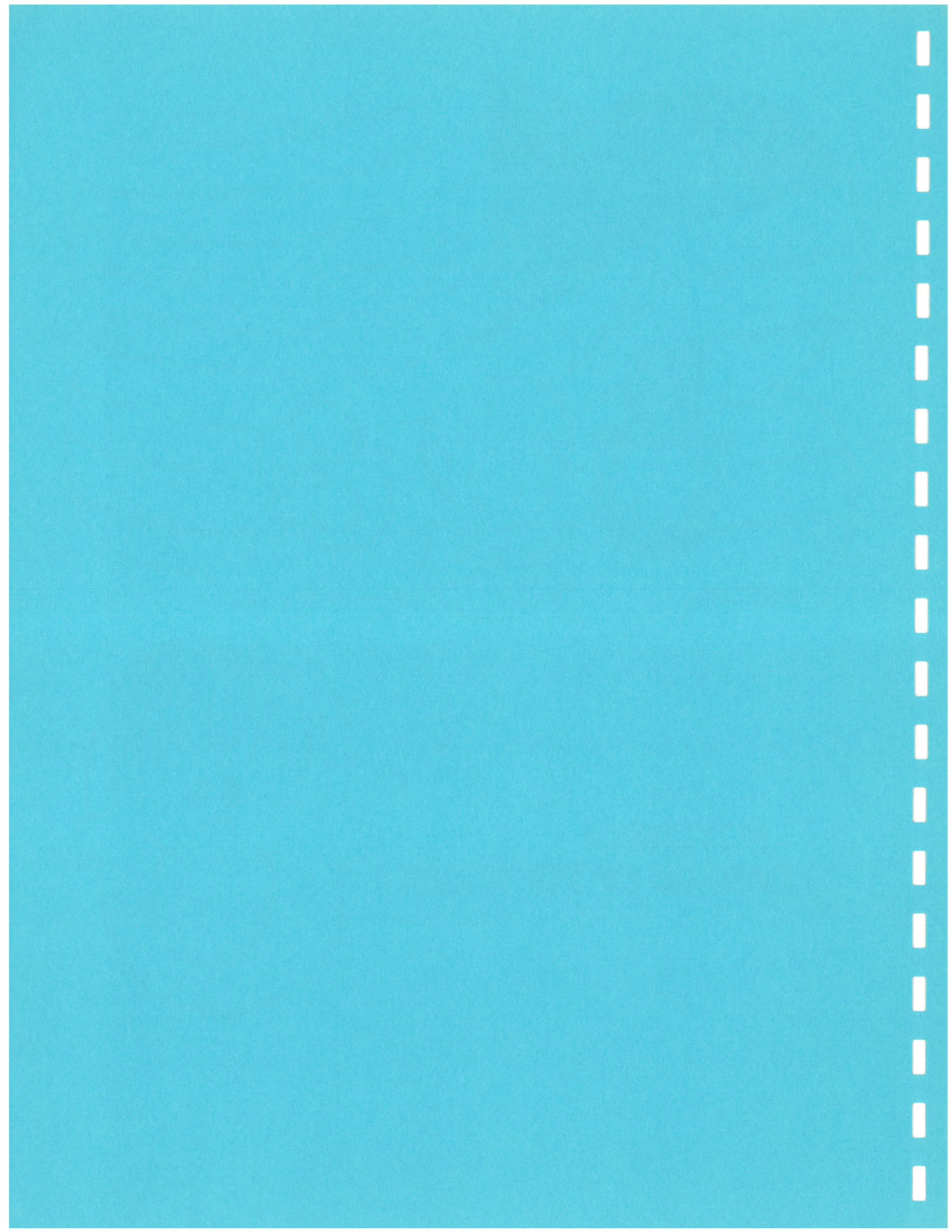

NOVEMBER PARADE OF PRESIDENTS



OPENING

LINCOLN

BY: Jennifer Casuga
12 years old

- L is for the lives he saved
- I is for his interest in learning
- N is for his never ending love given equally to all men regardless of race.
- C is for the cold nights he spent during his childhood
- O is for the open mind
- L is for the lawyer he became
- N is for the new freedom he gave to slaves

In 1861, Abraham Lincoln became the sixteenth President of the United States of America. He began freeing the slaves in 1863. On April 15, 1865, Abraham Lincoln was shot at Ford's theatre and died the next day. During this short time, he had given Blacks everywhere a new beginning.

CEREMONY

BY: Doug Kroll

More than 100 years ago Americans elected James A. Garfield as their 20th president. He was a man of great character.

As a young boy, a friend gave him a set of rules which transformed his life. He followed them until the day

1881 he died as president, killed by an assassin's bullet.

President Garfield's Rules were:

- Make few promises
- Always speak the truth
- Never speak evil of anyone
- Keep good company or none
- Never play games of chance
- Drink no intoxicating drinks
- Remember, good character is above everything else
- Never borrow if you can possibly help it
- Keep yourself honest, if you would be happy

A century later, President Garfield's rules are still appropriate for all of us.

CEREMONY

BY: Doug Kroll

Our greatest presidents have always turned to prayer in times of crisis. WE recall the moving story of George Washington kneeling in the snow at Valley Forge to ask for God's assistance when the fate of the fledgling nation hung in the balance.

Abraham Lincoln, on the eve of the Battle of Gettysburg, tells us that "I went into my room and got down on my knees in prayer."

After the shock of Pearl Harbor, President Roosevelt told us he took courage from the thought that "the vast majority of the members of the human race" joined us in a common prayer for victory as we fought for "freedom under God"

Let us follow the example of our greatest presidents and pause for a moment of silent prayer to God.

PAGE 2 NOVEMBER PARADE OF PRESIDENTS



SPARKLERS

Two Scouts are having an argument.

- A. Certs is a candy mint!
- B. Certs is a breath mint!
- A. (Leaning closer) Certs is a candy mint!
- B. (Feigning illness) You're right - Certs is a candy mint!

Two Scouts

- A: Enters galloping, stops and neighs and whinnies
- B. "What are you doing?"
- A. "Just horsing around"

ATTENTION! ATTENTION! (Person runs on saying this. When he gets everyone's attention he says. "I just love attention" and runs off.)

Cheers

CHERRY TREE CHEER: Holding ax in hands, swing three times and yell "chop, chop, chop"

Valley Forge Cheer: Pat yourself on the back

Let's Hear it for the President Cheer: Put your hand to your ear, as if listening

Liberty Bell Cheer: Ding, ding, ding, dong!

Canidate's cheer: Vote, Vote, Vote!

NO SKIT

As many characters as you wish are used for this skit. The first actor walks on stage in tears. He carries on, blowing his nose and crying incessantly. Soon another actor enters and asks what's wrong. The first actor whispers into the

ear of the second, and soon they both begin to crying and wailing. This continues with more actors, and each begins to cry. Finally, one actor enters and asks the whole group "What's the matter? Why is everyone crying?" The whole group answers in unison " We don't have a skit"

SONGS

**WHEN JOHNNY COMES
MARCHING HOME**

AMERICA

PATRIOTIC SONGS

CRAFT

STICK PEOPLE

Material:

- Craft sticks
- Construction paper
- 7mm wiggle eyes
- yarn
- 5mm pink pom poms
- 1" white Pom poms
- Black covered wire

1. Using pattern A cut out clothing back ground.
2. Using pattern B cut out 2 hands
3. Decide on accessories to complete outfit and glue on clothing background.
4. Glue white pom pom to top of clothing background to form head.
5. Glue hands to ends of arms
6. Glue yarn hair or hats on
7. Glue pink rose pom pom to center of the face
8. Glue eyes above the nose
9. Cut 1/2" wire, shape into smile and glue on .

Can be made into pilgrims different presidents of can also be made into Cub Scouts for Blue & Gold

PAGE 3 NOVEMBER
PARADE OF PRESIDENTS



CRAFTS CONTINUED

SKIT

THE WHITE HOUSE
MONTEREY COUNCIL

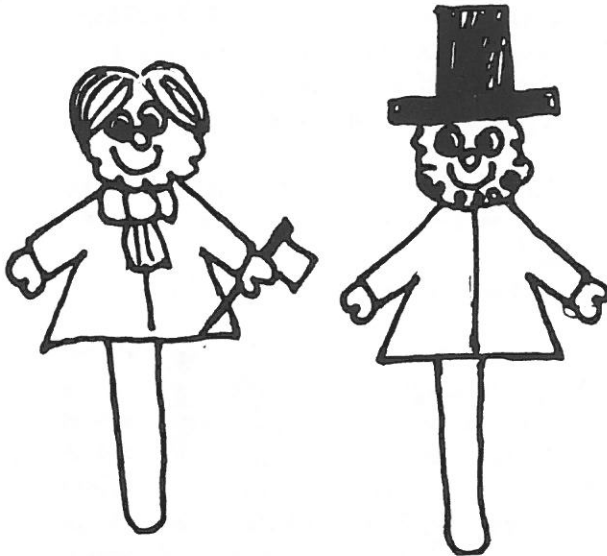

1st Cub: if you were to make a trip to Washington, D.C, you would be sure to visit the White House. It would look much as it has for more than 150 years. Yet in those years much has happened to it as well as to the lives of its _____ Presidents who have lived there.

2nd Cub: Although he was our only President never to live in the White House, George Washington picked out the present location for the White House.

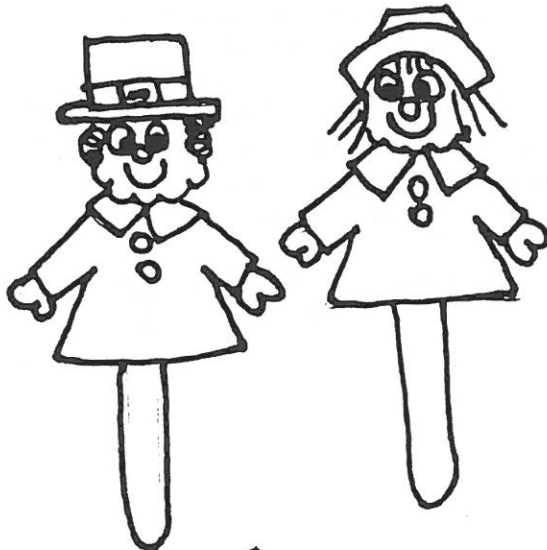

3rd Cub: Industrial progress made its mark on the White House. President Polk added gas lights and President Filmore adds the gas stove. Telephone lines were added by President Hayes and President Harrison added electric lights.

4th Cub: Theodore Roosevelt added the large wings we see today, and had Congress make the White House naem official.

5th Cub: President Truman completely rebuilt the house, using most the original material.

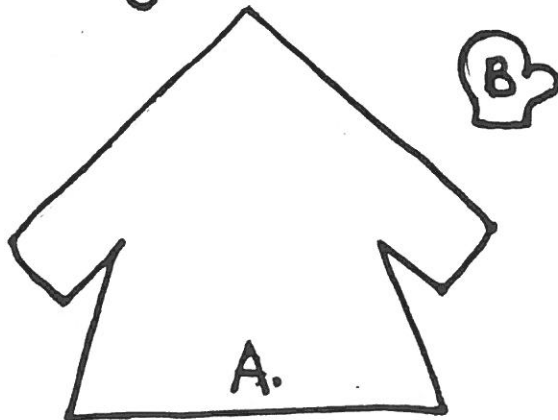

6th Cub: When you make your visit to the White House, perhaps you will hear echoes form the lives of past occupants and learn the prayer spoken by the first President to live there, John Admas, who siad: "Heaven bestow the best of blessing on this house and all that shall hereafter inhabit it. May none but honest and wise men ever rule under this roof."

**PAGE 4 NOVEMBER
PARADE OF PRESIDENTS**



**A THANK YOU TO THE WIFE OF
A SCOUTER:**

This thank you is given to _____,
a scouter's wife for:

1. Ironing his uniform so that he is always neat appearing.
2. Taking messages for him when he is gone
3. Encouraging him to go on when he wants to give up.
4. Helping with refreshments when needed
5. Going places where you may not want to go.
6. Helping him get ready to go on overnights and doing up the dirty clothes when he gets back.
7. For being a good listener

FAMOUS AMERICAN SKIT

Leader: Tonight we offer you a few famous sayings by our Presidents, and we will let you guess who? If you do not know it, then we will give you a clue.

(The clue will be a silhouette of the President out of black paper and mounted on a stick for each Cub Scout to hold up after a minute of letting your audience guess who?)

1. As I would not be a slave, so would I not be a master
Abraham Lincoln
2. Speak softly — and carry a big stick
Theodore Roosevelt
3. If men and women are in chains, anywhere in the world, then freedom is endangered everywhere
John F. Kennedy
4. One man with courage makes

a majority.
Andrew Jackson

5. I am a free man, an American, a United States Senator, and a Democrat, in that Order.

Lyndon B. Johnson

6. Mankind must put an end to war, or war will put an end to mankind

John F. Kennedy

7. Far better it is to dare mighty things, to win glorious triumphs, even though checkered by failure, than to take rank with poor spirits who neither enjoy much nor suffer much, because they live in the gray twilight that knows not victory nor defeat.

Theodore Roosevelt

8. This world of compensation and he who would be no slave must consent to have no slave.

Abraham Lincoln

9. There is no indispensable man
Woodrow Wilson

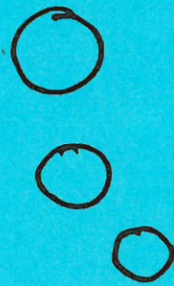
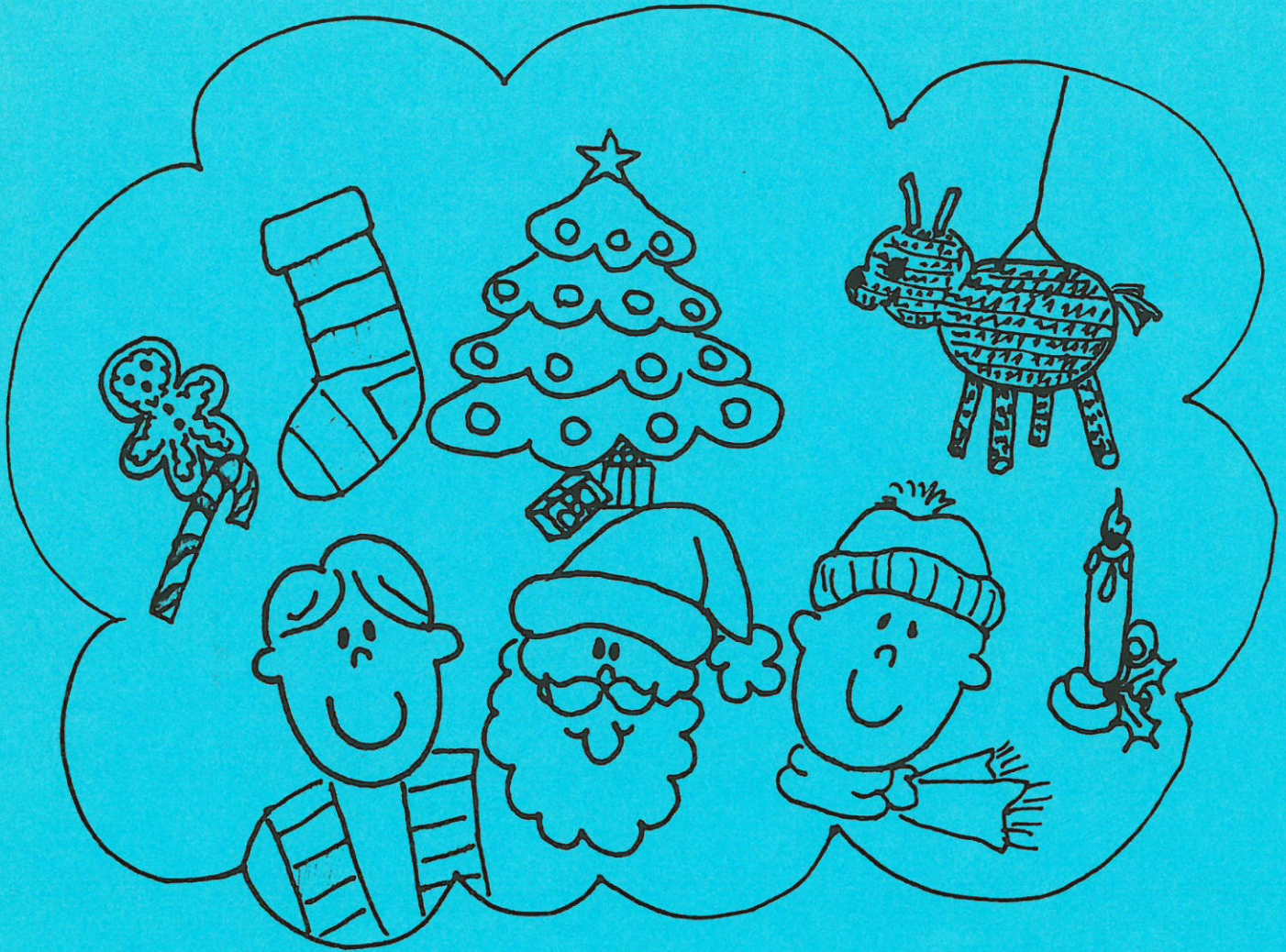

**DECEMBER
CUSTOMS OF COUNTRIES**



DECEMBER CUSTOMS OF COUNTRIES



OPENING

CHRISTMAS
BY: Jennifer Casuga

- C** is for the Christmas Cheer
- H** is for the holly
- R** is for the racing time until we can be jolly
- I** is for the inside feelings shared between each nation
- S** is for the smiling faces caused by the occasion
- T** is for the Christmas tree
- M** is the bing Merry
- A** is for the apples baked to the color of a cranberry

And now the most important thing of all, without a doubt

- S** is for the Son of God who this is all about

CLOSING

May the spirit of the holiday season, which is **PEACE, JOY AND LOVE**, fill each and every one of us here tonight, so that we may continue to spread this spirit throughout the coming year.

CHEERS

SANTA CLAUS CHEER: Ho, Ho Ho, Merry Christmas

Christmas Lights Cheer: Open and close hands three times yelling blink, blink, blink

Santa's Sleigh cheer: Voices simulate bells, Ring, ring, ring, ring, ring.

Eager Children cheer: (yelling loudly) Wake Up! It's Christmas Morning.

Naughty Children Cheer: (Sighing) Oh, just a lump of coal!

Grandma's Present Cheer: (Groaning) Pajamas again.

Frosty's Cheer: Thumpety, thump, thump, Thumpety, thump, thump

Hannukah Cheer: Dreidl, dredil, dreidl

CRAFT

MACARONI CANE

Materials: Wagon Wheel macaroni
Red paint
White paint

1. Spray five pieces of macaroni white
2. Spray five pieces of macaroni red.
3. Alternating colors glue together in the shape of a cane.

**PAGE 2 DECEMBER
CUSTOMS OF COUNTRIES**



CRAFTS CONT'D

GLITTERED STAR

Materials: 5 craft sticks
gold glitter
gold thread
glue

1. Glue craft sticks into a star as shown. Let dry.
2. Cover both sides completely with glue and sprinkle with gold glitter.
3. Tie a loop through one of the star points for hanging.

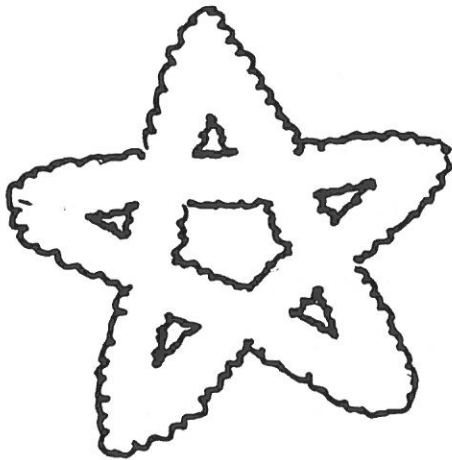
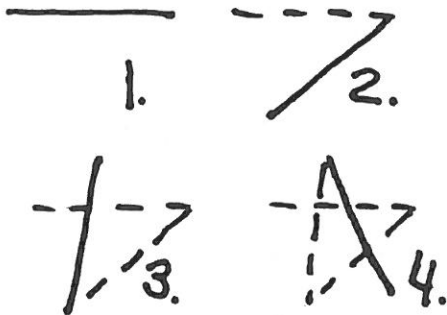

SONG

**MY AUNT CAME BACK
REPEAT SONG**

***My Aunt Came Back**

From Old Japan/ and she brought
me back/ A Paper Fan

***My Aunt came back/**

From the County Fair/ and she
brought me back/A rocking chair

***My Aunt Came back**

From Holland too/ and she brought
me back/ a Wooden shoe

***My Aunt came back**

From Old Belgium/ and she brought
me back/some bubble gum

***My Aunt came back**

From Kalamazoo/ and she brought
me back/ Some Nuts like you

Traditional Christmas Carrols are
fun for Christmas

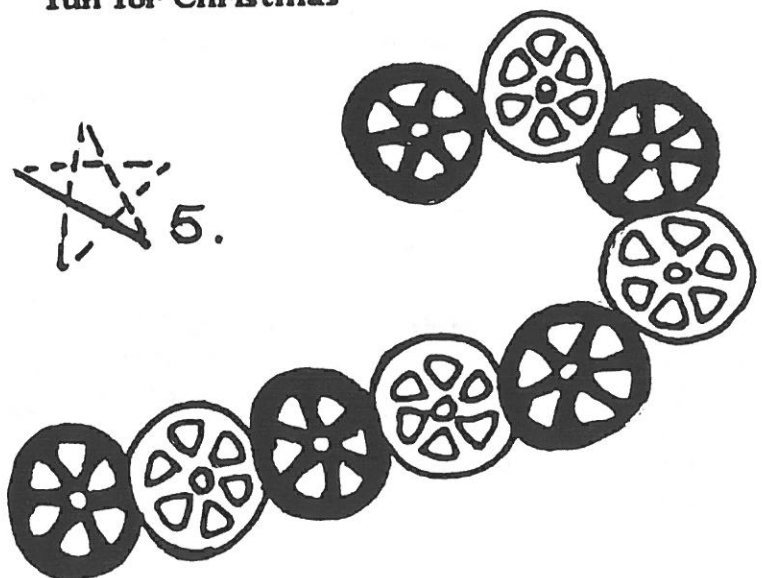

PAGE 3 DECEMBER
CUSTOMS OF COUNTRIES

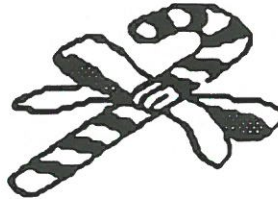

CHRISTMAS TRADITIONS

Characters: 6 boys.

Arrangement: Each boy comes on stage holding the object he's speaking about, or a poster with an appropriate picture on it. He can read his lines, or they can be read by a narrator.

- #1. The Christmas Tree: The custom of decorating small evergreen trees at Christmas time began in Germany. However, it reached America before it arrived in England. The German settler in Pennsylvania decorated the trees with lights, sweets and colored paper. That is how the Christmas tree became part of our traditional Christmas.
- #2. The Mistletoe: Ancient Celtic priests believed mistletoe had medicinal powers and was sacred. They thought it brought good fortune. Mistletoe was also considered the plant of peace, and under it, enemies met and reconciled their differences. From this ceremony came the English custom of kissing beneath it - the one tradition that has survived to the present.
- #3. The Christmas Wreath: During the 16th century in Germany, branches of fir or spruce were intertwined in a circular shape. This symbolized the love of God which had no beginning or end. One legend tells of a young girl of Bethlehem who wept because she had nothing to bring to the Christ Child but a crown of holly leaves. The babe touched the crown and leaves gleamed and scarlet berries appeared where her tears had fallen.
- #4. The Christmas Candle: Medieval Christians believed that ON Christmas Eve, the Christ Child wandered through town and country side in search of those who believed in him. On that night they placed candles at their windows to guide him.
- #5. The Poinsettia: This Christmas flower was discovered in Mexico in 1828 by Dr. Joel Poinsett. The people of Mexico and Central America call it "Flor de La noche buena" or flower of the Holy Night, because it reaches full bloom at Christmas.
- #6. The Christmas Card: At Christmas in 1843, in London, "A Christmas Carol" by Charles Dickens had just been published. A friend, Sir Henry Cole, had an artist friend design a Christmas greeting to send to his friends. This was to be the first Christmas card. It took more than 30 years for them to become popular. They were first introduced in the United States in the late 1870's.

PAGE 4 DECEMBER
CUSTOMS OF COUNTRIES



"THE BEST" GIFT OF ALL

(All the boys in the den hurry onto the stage with wrapped Christmas gifts in their hands, except one who is empty handed.)

They greet each other and form a little group and all begin talking at once. They are on their way to school and each are taking a gift to their teacher. The one boy who does not have a gift in his hand has a big smile on his face and the others are frowning and grumbling and arguing about whose gift is biggest and best.

1. Complains about the ribbon on his package is coming off.
(Pulls at it and frowns.)

Smiling Boy: (without package says: "Let me help" and pretends to be straightening the bow.

2. (in grumbling mood) says: "I sure hope she gives me an "A" for giving her this dumb thing" and holds it up for all to see, and drops it.

Smiling boy: (Runs over and picks it up and hands it back to him.)

3. (Frowning gerribly) Catches his finger in the corner of his package and tears it a little and then pouts and grumbles.)

Smiling boy pats him on the shoulder and says: "Thats all right, it's not noticable.

4. (Grumbles) "Why did my mom make me bring this dumb thing?" As he trips and falls sending the package flying.

Smiling boy: Picks it up and hands it to him.

(Then they all turn and say to Smiling boy:

"Hey, where's your gift you're giving the teacher?"

Smiling boy: "I didn't have enough allowance to buy one."

1. "Hey, Johnny, you're the only one who's been smiling and cheerful this morning. You're giving the best gift of all!"

(All the other boys stop as if thinking and then say together:
"YOU'RE RIGHT, HE'S GIVING GOODWILL TO EVERYONE!!"

Then with big smiles on their faces they all throw their packages down and say: "We're all going to give GOODWILL and all run off stage happily motioning for the smiling bly to join them.

PAGE 5 DECEMBER CUSTOMS OF COUNTRIES



GAMES

STIR THE CHRISTMAS CAKE

You will need one wooden spoon and a chair for all but one player. One player is chosen to be the cook. Arrange chairs in a circle. The cook stands in the middle of the circle and says "First we have to stir the Christmas cake. We will stir and stir and stir..." When the spoon is dropped, everyone has to change chairs, the cook runs for a chair too. The one left without a chair is the new cook.

* * * *

CHRISTMAS CHARADES

This is a good game for your den meetings. Divide the den into teams of twos. The leader gives each team a slip of paper with suggested Christmas parts (decorating the tree, hanging stockings, etc.). Each team in turn is to act out their part while the other teams guess what they are doing.

* * * *

CRANBERRY ROLL

Have ready an old page from a calendar with large numbers on it. Lay it on the floor, six feet away from starting line. Each player takes turns at rolling the 6 cranberries, one at a time onto the calendar sheet. He then totals his score. The player with the highest score is the winner.

* * * *

TRIM THE TREE

Line up players for a relay. Attach large sheets of paper to the opposite wall and give each boy a different color crayon. On signal the first boy runs to his paper and outlines a Christmas tree. Then the next boy runs up and draws a stand. The others draw ornaments or lights. The first team to trim its tree wins.

* * * *

CHRISTMAS STOCKING CONTEST

Divide the den into teams for a relay. Give each boy an apple. The first boy in each line gets a spoon. Have a Christmas stocking for each team hung at the other end of the room. On signal the first boy in each line places his apple on the floor, then picks it up with a spoon, runs to the stocking, puts the apple in and runs back to tag the next person in line. Let the winners and losers eat their apples as prizes.

* * * *

PAGE 6 DECEMBER CUSTOMS OF COUNTRIES



CUSTOMS OF COUNTRIES

NUREMBERG CHRISTMAS FAIR - GERMANY

In 1639 the city of Nuremberg began selling its Christmas goods in a market. Now, a girl dressed as the Christ Child, who German legend says, brings presents on Christmas Eve, steps onto the balcony of the church at the town's main square and pronounces the fair open. Everyone sings holiday music. In the three weeks that follow, shoppers go from stall to stall looking for decorations, presents, and holiday foods. Townspeople say that the Christ Child himself does His shopping at the fair.

ST. NICHOLAS DAY - EUROPE

In the fourth century St. Nicholas was the bishop of Myra in present-day Turkey. Legend has it that by leaving a bag of gold for three girls of three successive nights, he prevented their being sold into slavery. Today St. Nicholas still brings gifts to children in parts of France, Germany, and Switzerland. He's a special favorite in the Netherlands, where as "Sinterklass" dressed in bishop's robes, he arrives by ship on December 5. That evening families exchange presents and afterward, children leave carrots and hay in their shoes for St. Nicholas's horse. The next morning they'll receive switches if they've been bad, and candies and presents if they've been good.

HANNUKAH - JEWISH

More than 2,000 years ago, when the Syrian King Antiochus IV occupied Jerusalem, he forced the Jews to worship the Greek gods. For three years, Judah the Maccabee led a rebellion against the Syrians, and when he finally defeated them, the Jews could worship freely again. To rededicate the Temple, they cleaned it from top to bottom and then had to relight the menorah, a candelabrum. But only enough oil for one day could be found, and it would take eight days to get new oil. Incredibly, the little bottle of oil did last eight days, and Hannukah celebrates both this miracle and the "Rededication." Today, families gather around a special Hannukah menorah and light one candle on the first night of Hannukah, two on the second, and so on, for all eight nights of the festival. There are songs, stories, presents, and prayers, and children play games of chance with spinning tops called dreidels.

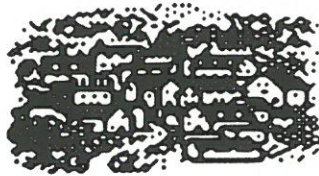

CUSTOMS OF COUNTRIES

YULETIDE LADS - ICELAND

This country has not one Santa but 13. They're descendants of Gryla the Ogre and very mischievous. Also known as the Christmas Men, they start visiting Icelandic homes, one per day, on December 12th, and by Christmas they've all arrived. No one sees them, but each one may leave a gift and some other signal of his presence: Door Slammer wakes people by slamming doors; Candle Beggar makes off with a few candles; and Meat Hooker, by dangling a hook down the chimney, might even make off with the Christmas roast.

POSADAS - MEXICO

For each of the eight nights before Christmas, Mexicans reenact Joseph and Mary's search for shelter (posadas) on the night of Jesus' birth. A group of friends goes to a home and sings traditional songs, asking the owner to let them in. After first refusing them, the master of the house invites them to enter, and the Posadas party begins. Each party has a piñata—a clay or papier-mach animal that hangs from the ceiling. Blindfolded, the children take turns swinging at it with a stick. When it finally breaks, everyone scrambles for the candies and toys that fall to the ground.

TA CHIU - HONG KONG

For their festival of peace and renewal, Taoists summon all their gods and ghost so the gods' collective power will renew their lives. Images of patron saints from all the local temples are raised in one place, where people make offerings to them. To end the festival, the priests read aloud the names of every person who lives in the area. Then they attach the list to a paper horse and burn it, so that it will rise to heaven.

PAGE 8 DECEMBER CUSTOMS OF COUNTRIES

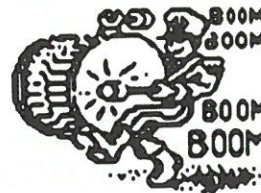

CLOSING CEREMONIES FOR ANY THEME

The following closing vespers have a good thought behind them and could be used effectively for the Closing of any Pack Meeting. They could be used as the closing itself or in connection with some spoken words from the Cubmaster or a Cub Scout.

Be sure to make copies to distribute to audience so they can easily sing along.

CLOSING VESPER (Tune: Tannenbaum, Oh Christmas Tree)

Quietly we now will part,
Pledging ever in our heart,
To strive to do our best each day,
As we travel down life's way.
Happiness we'll try to give,
Till all the world be joined in love,
Living in peace, under skies above.

A DAILY VESPER (Tune: Tannenbaum)

As I travel down life's way,
May I do something good each day.
May I ever thankful be,
For the blessings given me.
May I join my fellowman,
Doing for others, what I can.
So a better world we all will see
Living together in harmony.



PARTING VESPER (Tune: Tannenbaum)

Now it's time for us to go,
Taking with us a friendly glow,
From joining together in teamwork,
Our responsibilities ne'er to shirk,
May all of us, soon meet again,
And bring new friends, that we did win.
While we're travelling down life's way,
May our paths cross another day.

